

**INSTALLER / CONSUMER
SAFETY INFORMATION**

**PLEASE READ THIS MANUAL
BEFORE INSTALLING AND USING
APPLIANCE.**

WARNING!
**IF THE INFORMATION IN THIS
MANUAL IS NOT FOLLOWED
EXACTLY, A FIRE OR EXPLOSION
MAY RESULT CAUSING
PROPERTY DAMAGE, PERSONAL
INJURY OR LOSS OF LIFE.**

— Do not store or use gasoline
or other flammable vapors and
liquids in the vicinity of this or
any other appliance.

— **WHAT TO DO IF YOU SMELL
GAS:**

- Do not try to light any appliance.
- Do not touch any electric switch; do not use any phone in your building.
- Immediately call your gas supplier from your neighbor's phone. Follow the gas supplier's instructions.
- If you cannot reach your gas supplier, call the fire department.

**Installation and service must be
performed by a qualified installer,
service agency or the gas
supplier.**

**This appliance may be installed in an
after market permanently located
manufactured (mobile) home where not
prohibited by local codes.**

**This appliance is only for use with the
type of gas indicated on the rating plate.**

**This appliance is not convertible for use
with other gases unless a certified kit is
used.**



Pinnacle & Stardance Direct Vent, Rear Vent Gas Heater

Models:

SDVR: 3920-3936, 3960-3976

**PDV20: 2995, 2997, 4065-4067,
4069-4072, 4075-4077, 4080-4083**

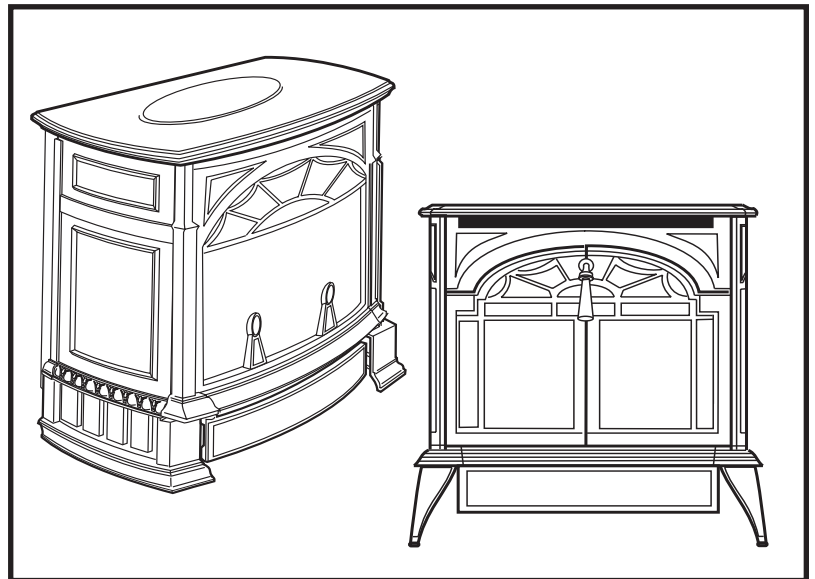

Homeowner's Installation and Operating Manual



**INSTALLER: Leave this manual with the appliance.
CONSUMER: Retain this manual for future reference.**

Table of Contents

PLEASE READ THE INSTALLATION & OPERATING INSTRUCTIONS BEFORE USING APPLIANCE.

Thank you and congratulations on your purchase of a Vermont Castings stove.

IMPORTANT: Read all instructions and warnings carefully before starting installation. Failure to follow these instructions may result in a possible fire hazard and will void the warranty.

Installation & Operating Instructions	Stove Dimensions	4
	Clearance Requirements	5
	Minimum Clearances, Parallel Installation, Corner Installation	5
	Minimum Clearances, Alcove Installation	6
	Mantel Clearances	6
	Hearth Requirements	6
	Gas Specifications	6
	Gas Inlet and Manifold Pressures	6
	High Elevations	7
	Horizontal Termination	7
	Vertical Termination	8
	Vent Termination Clearances	8
	General Venting Information - Termination Location	10
	Termination Clearances	11
	Vent Components	12
Installation	Install Optional FK28 Fan Kit	13
	Venting System Assembly - Direct Vent	14
	Rear Vent	14
	Through Side Wall / Vent Termination Below Grade	15
	Side Wall Termination Assembly	16
	Vent Termination Below Grade	17
	Vertical (Through the Roof) Vent Assembly	18
	Vertical Through Existing Chimney	19
	Fireplace Vent Termination Clearances	19
	Fireplace Installation Requirements	21
	Connect Gas Supply Line	23
	Burner Information	23
	Complete the Assembly	23
	Install ON/OFF Switch (R Models Only)	23
	Install the Front Plate	24
	Thermostat Connection	24
	Install the Log Set	25
Operation	Operable Doors	26
	Your First Fire	26
	Pilot and Burner Inspection	26
	Flame & Temperature Adjustment	26
	Flame Characteristics	26
	Lighting and Operating Instructions	28
	Troubleshooting	29
	Instructions for RF Comfort Control Valve	30
	Fuel Conversion Instructions	33
Maintenance	Annual System Inspection	37
	Logset and Burner Cleaning	37
	Care of Cast Iron	37
	Cleaning the Glass	37
	Glass Replacement	37
	Gasket Replacement	38
	Inspect the Vent System Annually	38
	Check the Gas Flame Regularly	38
	Stove Disassembly	39
	Wiring Diagrams	39
Replacement Parts	40
Optional Accessories	43
Warranty	47
Energide	48

Installation & Operating Instructions

The Pinnacle (PDV20) and Stardance (SDVR) Direct Vent Room Heater, Model Nos. 3920-3936, 3960-3976, 2995, 2997, 4065-4067, 4069-4072, 4075-4077, 4080-4083 are vented gas appliances listed to ANSI Standard Z21.88-2005 and CSA-2.33-2005 for Vented Room Heaters, and CSA 2.17-M91, Gas-Fired Appliances For Use at High Altitudes.

The installation of the PDV20 and SDVR Direct Vent Room Heaters must conform with local codes, or in the absence of local codes, with National Fuel Gas Code, ANSI Z223.1/ NFPA 54 — latest edition and CSA B-149.1 (EXCEPTION: Do not derate this appliance for altitude. Maintain the manifold pressure at 3.5" w.c. for Natural Gas and 10" w.c. for LP gas at maximum input.) Refer to Page 37 (RF only).

This appliance is only for use with the type of gas indicated on the rating plate. This appliance is not convertible for use with other gases unless a certified kit is used.

Installation and replacement of gas piping, gas utilization equipment or accessories, and repair and servicing of equipment shall be performed only by a qualified agency, preferably NFI or WETT (Canada) certified. The term "qualified agency" means any individual, firm, corporation, or company that either in person or through a representative is engaged in and is responsible for (a) installation or replacement of gas piping, or (b), the connection, installation, repair, or servicing of equipment, who is experienced in such work, familiar with all precautions required, and has complied with all the requirements of the authority having jurisdiction.

The PDV20 and SDVR Direct Vent Room Heaters should be inspected before use and at least annually by a qualified service agency. It is imperative that control compartments, burners, and circulating air passageways of the appliance be kept clean.

The PDV20 and SDVR Direct Vent Room Heaters and the individual shut-off valve must be disconnected from the gas supply piping during any pressure testing of that system at test pressures in excess of 1/2 psig (3.5 kPa).

The PDV20 and SDVR Direct Vent Room Heaters must be isolated from the gas supply piping system by closing the individual manual shutoff valve during any pressure testing of the gas supply piping system at test pressures equal to or less than 1/2 psig.

An accessible tap is located above the pilot/on-off knob for checking the inlet pressure.

'Direct Vent' describes a sealed combustion system in which incoming outside air for combustion and outgoing exhaust enter and exit through two separate concentric passages within the same sealed vent system. The system does not use room air to support combustion. The Direct Vent system permits the gas appliance to be vented directly to the outside atmosphere through the side of the house or vertically through the roof.

This appliance is approved for bedroom installations in the U.S. and Canada.

This appliance may be installed in an aftermarket* manufactured (mobile) home, where not prohibited by state or local codes.

20007066

WARNING: Operation of this heater when not connected to a properly installed and maintained venting system can result in carbon monoxide (CO) poisoning and possible death.

The PDV20 and SDVR Direct Vent Room Heater, when installed, must be electrically grounded in accordance with local codes or, in the absence of local codes, with the National Electrical Code ANSI/NFPA 70, (latest edition), or of the current Canadian Electrical Code C22.1.

Due to high temperatures this appliance should be located out of traffic and away from furniture and draperies.

WARNING: This appliance is hot while in operation. Keep children, clothing, and furniture away. Contact may cause burns or ignition of combustible materials.

Children and adults should be alerted to the hazards of high surface temperatures and should stay away to avoid burns or clothing ignition. Young children should be carefully supervised when they are in the same room as the appliance.

Clothing or other flammable materials should not be placed on or near the appliance.

Any safety screen, glass or guard removed for servicing an appliance must be replaced prior to operating the appliance.

The appliance area must be kept clear and free from combustible materials, gasoline, and other flammable vapors and liquids.

The flow of combustion and ventilation air must not be obstructed. The installation must include adequate accessibility and clearance for servicing and proper operation.

WARNING: Do not operate the Room Heater with the glass panel removed, cracked or broken. Replacement of the panel should be done by a licensed or qualified service person.

Do not use this appliance if any part has been under water. Immediately call a qualified service technician to inspect the appliance and to replace any part of the control system and any gas control which has been under water.

Do not burn wood, trash or any other material for which this appliance was not designed. This appliance is designed to burn either natural gas or propane only.

This gas appliance must not be connected to a chimney flue serving a separate solid-fuel burning appliance.

CAUTION: Label all wires prior to disconnection when servicing controls. Wiring errors can cause improper and dangerous operation.

Verify proper operation after servicing.

Proposition 65 Warning: Fuels used in gas, woodburning or oil fired appliances, and the products of combustion of such fuels, contain chemicals known to the State of California to cause cancer, birth defects and other reproductive harm.

California Health & Safety Code Sec. 25249.6

* **Aftermarket:** Completion of sale, nor for purpose of resale, from the manufacturer.

Stove Dimensions - Pinnacle Direct Vent Gas Heater

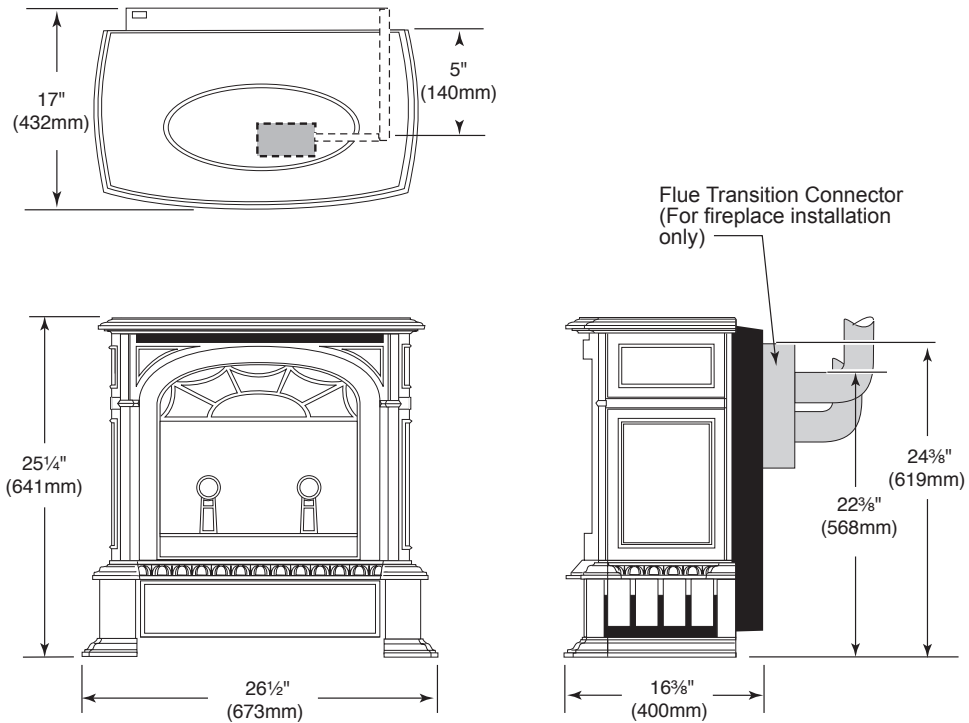

3457

Fig. 1 PDV20 dimensions.

Stove Dimensions - Stardance Direct Vent Gas Heater

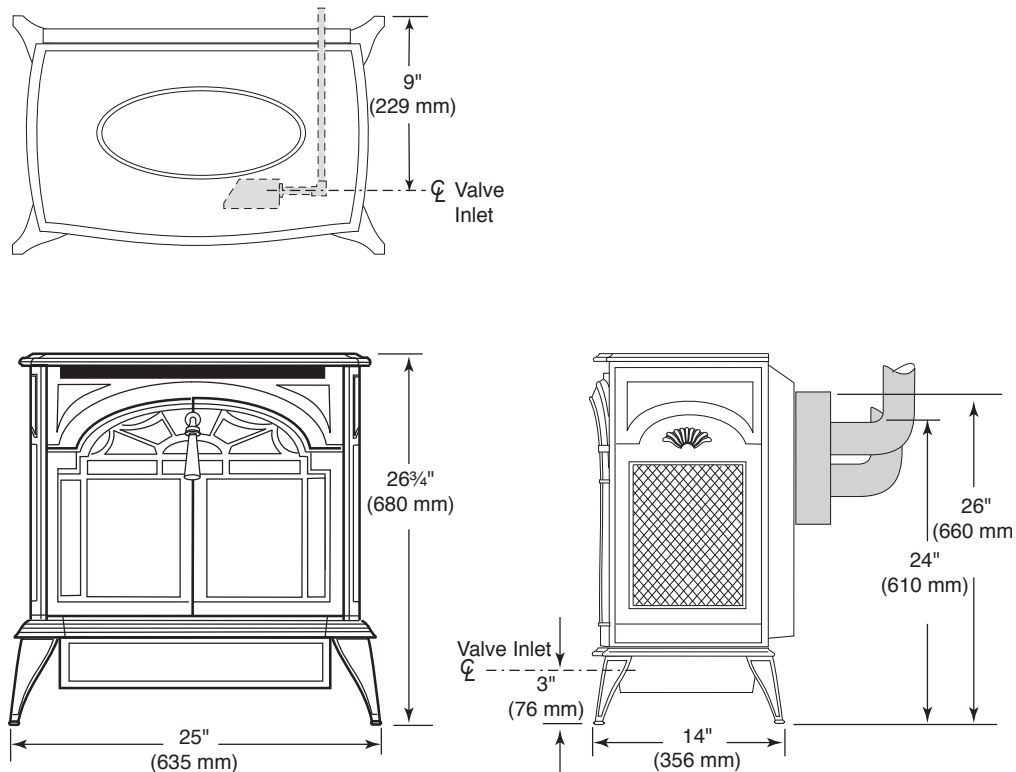

3457

Fig. 2 SDVR dimensions.

Clearance Requirements

Minimum Clearances to Combustible Materials

Measure side clearances as shown in Figures 3, 4 and 5 from the outer edge of the cast iron stove top. Measure rear clearances from the outermost surface of the steel rear skirt.

The PDV20 and SDVR heaters are approved for installation into an alcove constructed of combustible materials to the dimensions and clearances shown on the next page.

The same clearances apply in a standard parallel installation.



WARNING:

• Always maintain required clearances (air spaces) to nearby combustibles to prevent fire hazard. Do not fill air spaces with insulation. All venting components must maintain a 1" (25mm) clearance to combustible materials. Maintain a 6" (152mm) clearance when using single wall pipe. Maintain a 2" (51mm) clearance on top and 1" (25 mm) on sides and bottom when venting straight off the rear.

- The gas appliance and vent system must be vented directly to the outside of the building and never be attached to a chimney serving a separate solid fuel or gas-burning appliance.
- Refer to the manufacturer's instructions included with the venting system for complete installation procedures.

Minimum Clearances

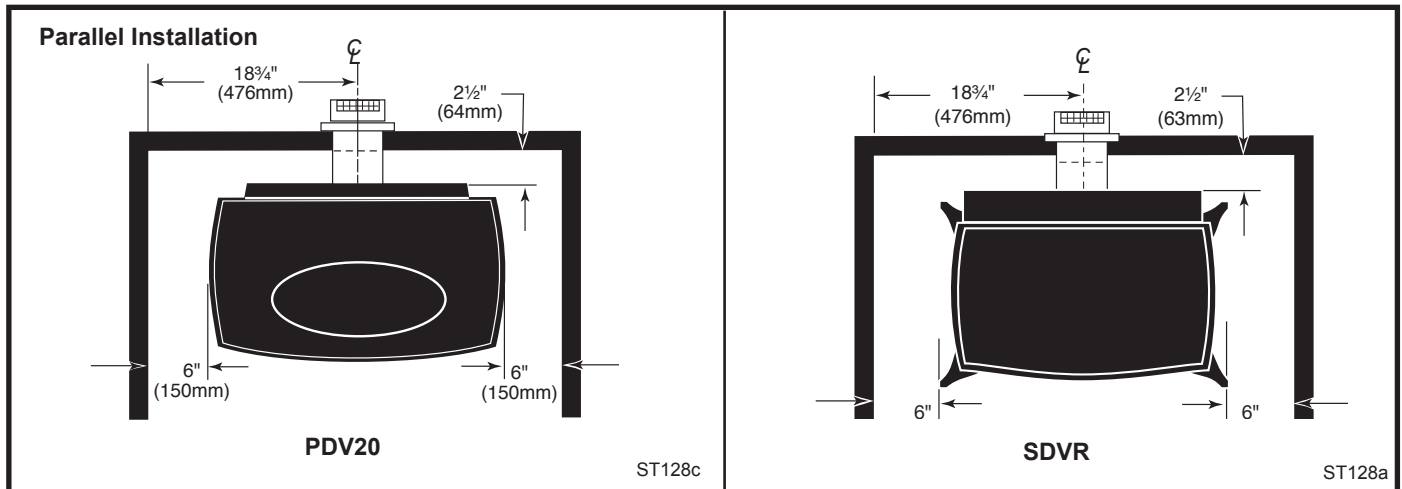

Fig. 3 Parallel installation minimum clearances and flue centerline.

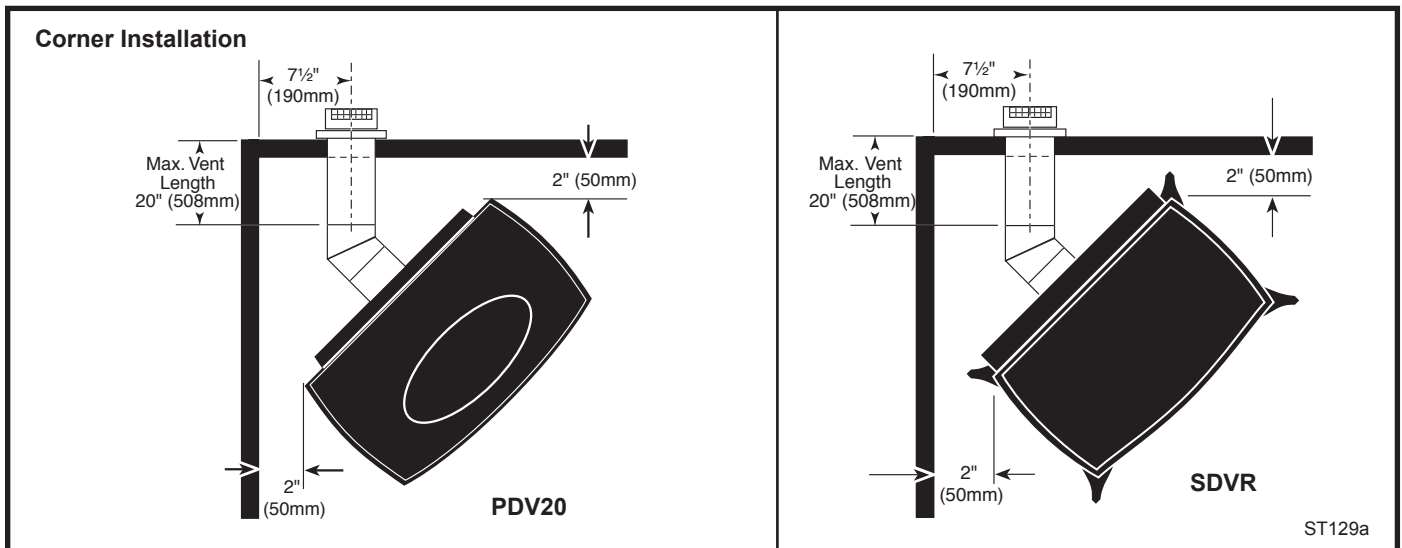

Fig. 4 Corner installation minimum clearances.

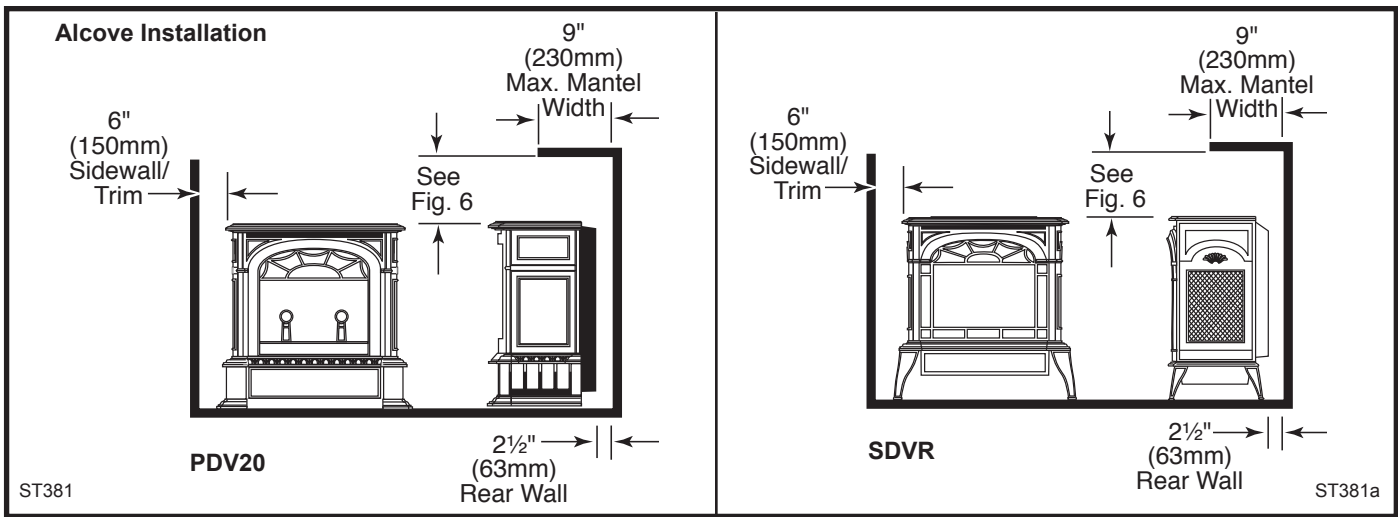

Fig. 5 Alcove installation.

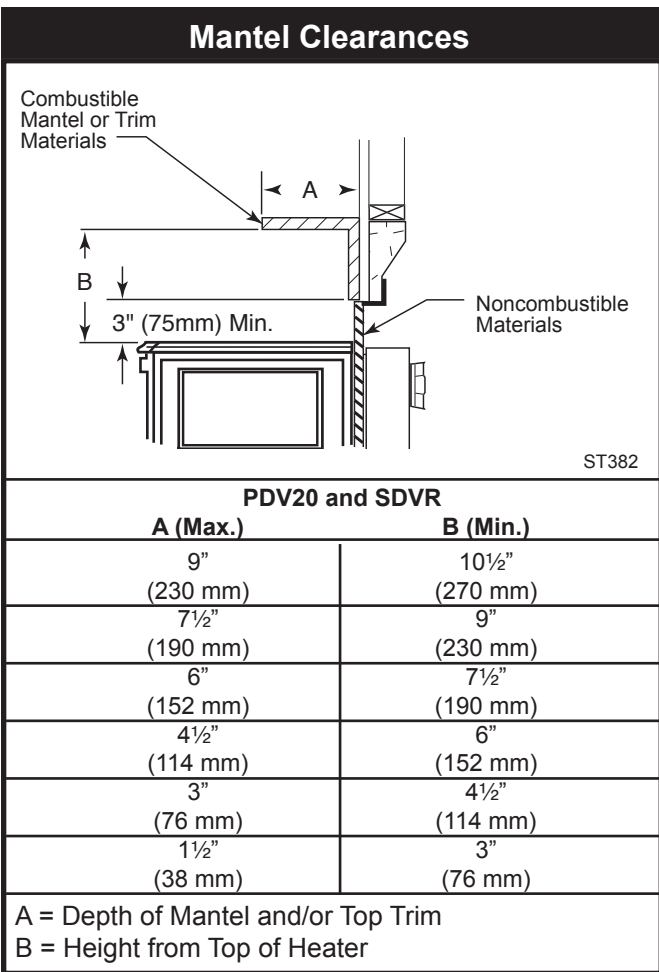

Fig. 6 Mantel / top trim clearances.

Hearth Requirements

The PDV20 and SDVR Heaters must be installed on rigid flooring. When the heater is installed directly on any combustible surface other than wood flooring, a metal or wood panel extending the full width and depth of the unit must be used as the hearth. There are no other hearth requirements.

Gas Specifications

Model	Fuel	Gas Control	Max. Input BTU/h	Min. Input BTU/h
PDV20RN	Nat	Millivolt	21,000	15,500
PDV20RP	Prop	Millivolt	21,000	16,500
PDV20RFN	Nat	Comfort Control	21,000	15,500
PDV20RFP	Prop	Comfort Control	21,000	16,500
SDVRRN	Nat	Millivolt	21,000	15,500
SDVRRP	Prop	Millivolt	21,000	16,500
SDVRRFN	Nat	Comfort Control	21,000	15,500
SDVRRFP	Prop	Comfort Control	21,000	16,500

Weight: Fully assembled 350 lbs.

Gas Inlet and Manifold Pressures

	Natural	LP (Propane)
Inlet Minimum	5.5" w.c.	11.0" w.c.
Inlet Maximum	14.0" w.c.	14.0" w.c.
Manifold Pressure	3.5" w.c.	10" w.c.

**Pinnacle / Stardance
Direct Vent / Rear Vent
Certified to:
ANSI Z21.88-2005 / CSA Z2.33-2005
Vented Gas Fireplace Heaters**

The installation must conform with local codes or, in the absence of local codes, with the National Fuel Gas Code, ANSI Z223.1/NFPA 54 - latest edition. (EXCEPTION: Do not derate this appliance for altitude. Maintain the manifold pressure at 3.5" w.c. for Natural Gas and 10" w.c. for Propane.)

High Elevations

Input ratings are shown in BTU per hour and are certified without deration for elevations up to 4,500 feet (1,370m) above sea level.

For elevations above 4,500 feet (1,370m) in USA, installations must be in accordance with the current ANSI Z223.1/NFPA 54 and/or local codes having jurisdiction.

In Canada, please consult provincial and/or local authorities having jurisdiction for installations at elevations above 4,500 feet (1,370m).

WARNING: Improper installation, adjustment, alteration, service or maintenance can cause injury or property damage. Refer to this manual for correct installation and operational procedures. For assistance or additional information consult a qualified installer, service agency, or the gas supplier.

Horizontal Termination

The vent must rise vertically a minimum of 24" (610mm) after the first elbow directly off the back of the unit, before the next elbow. The horizontal run may extend up to 20' (6m) and include a vertical rise of up to 40' (12m). (Fig. 7) Horizontal termination must also meet the criteria shown in Figures 9 and 10.

- Approved vent systems must terminate above and including the heavy line in Figure 7.
- Two 45° elbows may be substituted for each single 90° elbow.
- With a rise between 2' - 5', one 90° or two 45° elbows may be used (Excluding the first elbow directly off the back of the unit).

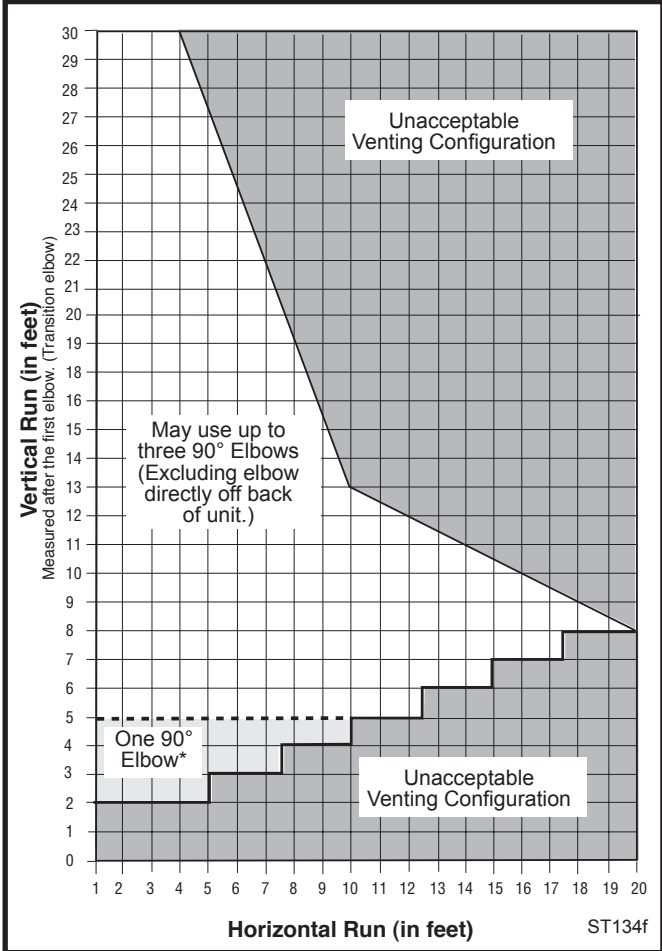

Fig. 7 Horizontal vent termination window.

* Not the transition elbow.

Vertical Termination

A vertical vent system must terminate no less than 8' (2.44m) and no more than 40' (12m) above the appliance flue collar. A 2¼" restrictor plate (supplied) must be used (where specified) in all vertically terminated vent systems. **NOTE: The restrictor plate supplied with the vertical termination should be discarded. Install restrictor plate supplied with stove directly at stove outlet.** A vertically terminated vent system must also conform to the following criteria:

- No more than three 90° elbows may be used. 90° elbow off back must be transition elbow.
- Two 45° elbows may be substituted for one 90° elbow. No more than six elbows may be used.
- Vent must rise a minimum of 2 feet before offset is used.
- Termination height must conform to roof clearance as specified in Figure 9.

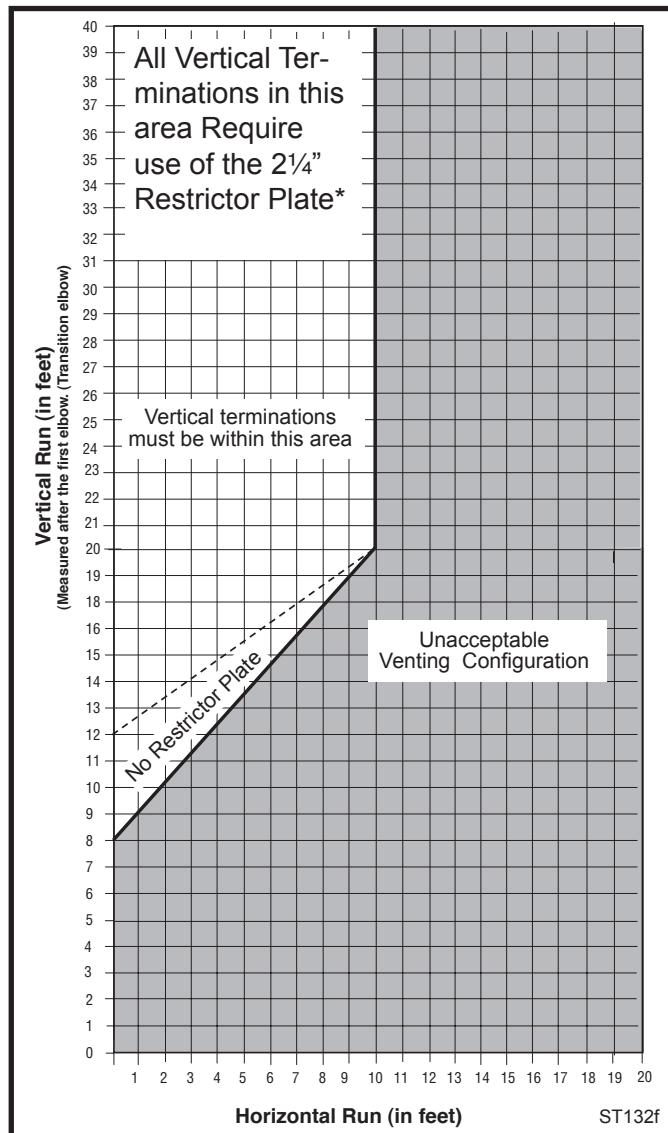

Fig. 8 Vertical vent termination window.

Vent Termination Clearances

When planning the installation, consider the location of the vent terminal and clearances. Some of the most common clearances to keep in mind are shown in Figure 9.

Important: All vent clearances must be maintained. Check your vent termination clearances against Figures 9 and 10 .

The vent should be placed so that people cannot be burned by accidentally touching the vent surfaces when the stove is operating.

The vent termination should be located where it cannot be damaged by such things as automobile doors, lawn mowers or snowblowers and it should be located away from areas where it could become blocked by snow, etc.

Some considerations are:

- Obstructions or impediments to venting.
- Nearby combustible materials that could come into contact with combustion exhaust gases.
- Other nearby openings {within 9" (230mm)} through which exhaust gas could reenter the building.
- All vegetation within 3' (914mm) that may interfere with the draft.

Other factors that influence where the installation will be sited include the location of outside walls, where additional heat may be desired in the home, where the family members gather most regularly, and perhaps most importantly, the distance limitations of the venting system.



IMPORTANT

- The horizontal termination must not be recessed into the exterior wall or siding.
- Horizontal vent runs must be level toward the vent termination.
- Clearances around the vent termination must be maintained.

Vent Termination Clearances

Your stove is approved to be vented either through the side wall, or vertical through the roof.

- **CFM Corporation does not require any opening for inspection of vent pipe.**
- **Only CFM Corporation venting components specifically approved and labelled for this stove may be used.**
- **Minimum clearances between vent pipes and combustible materials is one (1") inch (25mm), except where stated otherwise.**
- Venting terminals shall not be recessed into a wall or siding.
- Horizontal venting must be installed on a level plane without an inclining or declining slope.

There must not be any obstruction such as bushes, garden sheds, fences, decks or utility buildings within 24" from the front of the termination hood.

Do not locate termination hood where excessive snow or ice build up may occur. Be sure to check vent termination area after snow falls, and clear to prevent accidental blockage of venting system. When using snow blowers, make sure snow is not directed towards vent termination area.

Location of Vent Termination

It is imperative the vent termination be located observing the minimum clearances as shown in Figure 9.

General Venting Information - Termination Location

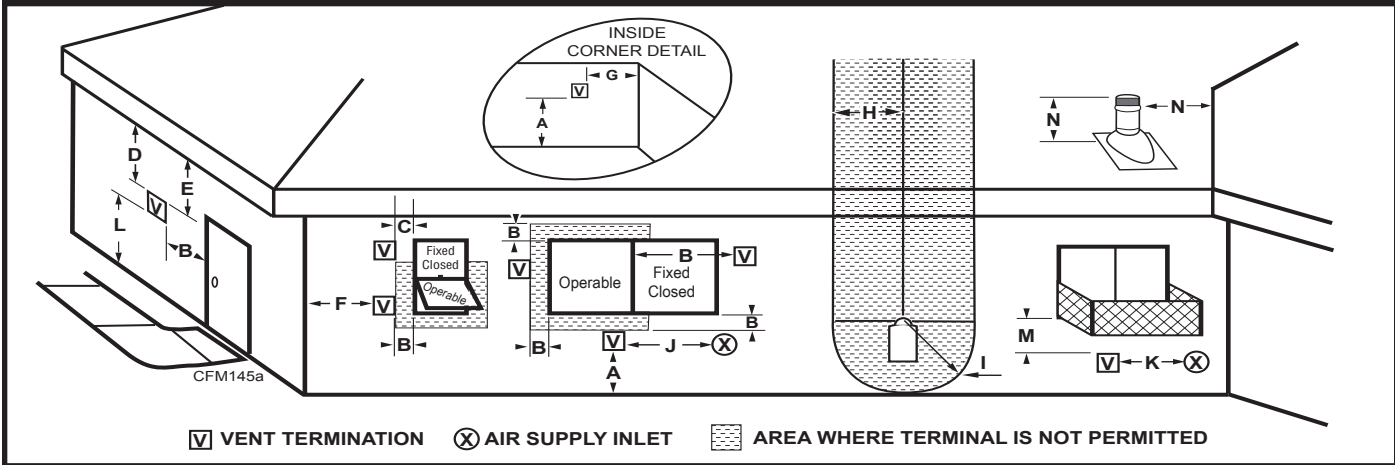

	Canadian Installations ¹	US Installations ²
A = Clearance above grade, veranda, porch, deck, or balcony	12" (30cm)	12" (30cm)
B = Clearance to window or door that may be opened	6" (15cm) for appliances < 10,000Btuh (3kW), 12" (30cm) for appliances > 10,000 Btuh (3kW) and < 100,000 Btuh (30kW), 36" (91cm) for appliances > 100,000 Btuh (30kW)	6" (15cm) for appliances < 10,000 Btuh (3kW), 9" (23cm) for appliances > 10,000 Btuh (3kW) and < 50,000 Btuh (15kW), 12" (30cm) for appliances > 50,000 Btuh (15kW)
C = Clearance to permanently closed window	12" (305mm) recommended to prevent window condensation	12" (305mm) recommended to prevent window condensation
D = Vertical clearance to ventilated soffit located above the terminal within a horizontal distance of 2' (610mm) from the center line of the terminal	18" (458mm)	18" (458mm)
E = Clearance to unventilated soffit	12" (305mm)	12" (305mm)
F = Clearance to outside corner	see next page	see next page
G = Clearance to inside corner (see next page)	see next page	see next page
H = Clearance to each inside of center line extended above meter/regulator assembly	3' (91cm) within a height of 15' (5m) above the meter/regulator assembly	3' (91cm) within a height of 15' (5m) above the meter/regulator assy
I = Clearance to service regulator vent outlet	3' (91cm)	3' (91cm)
J = Clearance to nonmechanical air supply inlet to building or the combustion air inlet to any other appliances	6" (15cm) for appliances < 10,000 Btuh (3kW), 12" (30cm) for appliances > 10,000 Btuh (3kW) and < 100,000 Btuh (30kW), 36" (91cm) for appliances > 100,000 Btuh (30kW)	6" (15cm) for appliances < 10,000 Btuh (3kW), 9" (23cm) for appliances > 10,000 Btuh (3kW) and < 50,000 Btuh (15kW), 12" (30cm) for appliances > 50,000 Btuh (15kW)
K = Clearance to a mechanical air supply inlet	6' (1.83m)	3' (91cm) above if within 10' (3m) horizontally
L = Clearance above paved sidewalk or paved driveway located on public property	7' (2.13m)†	7' (2.13m)†
M = Clearance under veranda, porch, deck or balcony	12" (30cm)‡	12" (30cm)‡

N = Clearance above a roof shall extend a minimum of 24" (610mm) above the highest point when it passes through the roof surface, and any other obstruction within a horizontal distance of 18" (450mm).

1 In accordance with the current CSA-B149 Installation Codes
 2 In accordance with the current ANSI Z223.1/NFPA 54 National Fuel Gas Codes
 † A vent shall not terminate directly above a sidewalk or paved driveway which is located between two single family dwellings and serves both dwellings
 ‡ only permitted if veranda, porch, deck or balcony is fully open on a minimum 2 sides beneath the floor:
 NOTE: 1. Local codes or regulations may require different clearances.
 2. The special venting system used on Direct Vent Stoves are certified as part of the appliance, with clearances tested and approved by the listing agency.
 3. CFM Corporation assumes no responsibility for the improper performance of the appliance when the venting system does not meet these requirements.

Fig. 9 Vent termination clearances.

Termination Clearances

Termination clearances for buildings with combustible and noncombustible exteriors.

Inside Corner

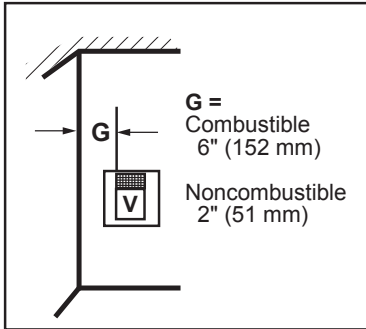

Outside Corner

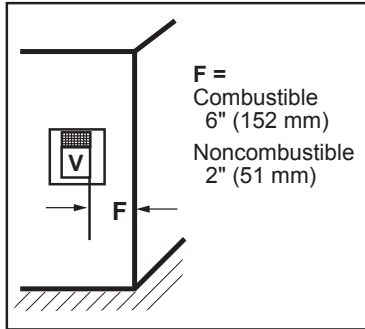

Alcove Applications*

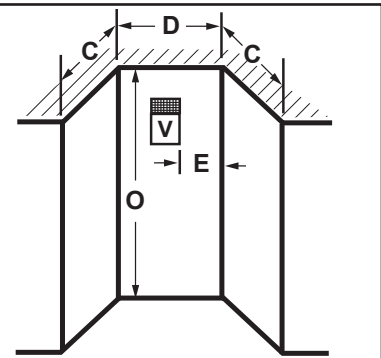

E = Min. 6" (152 mm) for non-vinyl sidewalls
 Min. 12" (305 mm) for vinyl sidewalls
O = 8' (2.4 m) Min.

Balcony - with no side wall

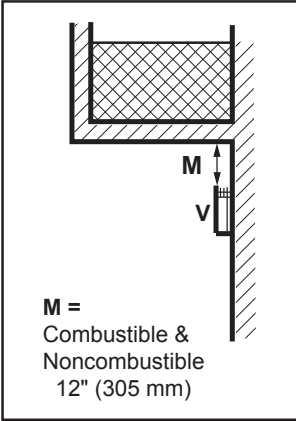

Balcony - with perpendicular side wall

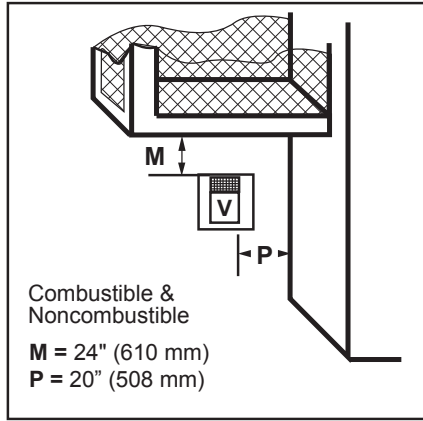

No. of Caps	D _{Min.}	C _{Max.}
1	3' (914 mm)	2 x D _{Actual}
2	6' (1.8 m)	1 x D _{Actual}
3	9' (2.7 m)	2/3 x D _{Actual}
4	12' (3.7 m)	1/2 x D _{Actual}

D_{Min.} = # of Termination caps x 3
 C_{Max.} = (2 / # termination caps) x D_{Actual}

584-15

***NOTE:** Termination in an alcove space (spaces open only on one side and with an overhang) is permitted with the dimensions specified for vinyl or non-vinyl siding and soffits. 1. There must be a 3' (914 mm) minimum between termination caps. 2. All mechanical air intakes within 10' (1 m) of a termination cap must be a minimum of 3' (914 mm) below the termination cap. 3. All gravity air intakes within 3' (914 mm) of a termination cap must be a minimum of 1' (305 mm) below the termination cap.

Fig. 10 Termination clearances.

Vent Components

The following kits are available to meet the needs of most installations. All pipe has a 7" outer diameter and includes a 4" diameter inner section. A (CG) designation indicates the part is finished in Charcoal Gray paint. Consult your dealer about other vent parts that may be appropriate to complete the installation.

CFM Corporation Vent Components

Rear Vent Kit

7TFRSRK

- (1) 20" Starter pipe (CG) for through wall installation
- (1) Side Wall Termination
- (1) Finishing Collar (CG)
- (1) Firestop
- (1) Zero Clearance Sleeve
- (1) Wall plate (CG)
- (1) Hardware Package

Min. Through the Wall Vent Kit

7TFSSK

- (1) 90-Degree Elbow (CG)
- (1) 24" Straight pipe (CG)
- (1) 24" - 42" Adjustable Straight Pipe
- (1) Side Wall Termination
- (1) Firestop
- (1) Zero-clearance sleeve
- (1) Hardware package
- (1) Finishing plate (CG)
- (1) Finishing collar (CG)
- (4) Charcoal Gray flue pipe rings

Starter Kit for

Below-Grade Installation

7TFSDVSKS

- (1) Snorkel Termination (7TDVSNORK)

Vertical Termination Kit, 1/12-6/12 Pitch 7TDVSKVA

- (1) Combination Horizontal Offset / Roof Support
- (1) Vertical Termination
- (1) Storm Collar
- (1) 1/12-6/12 Flashing
- (1) Finishing Plate (CG)
- (1) Finishing Collar (CG)
- (1) Polished Brass Flue Pipe Ring

- (1) Hardware Package

Vertical Termination Kit, 7/12-12/12 Pitch 7TDVSKVB

- (1) 7/12 - 12/12 Flashing
- and all of the other Vertical Termination parts.

Vertical Termination, Flat Roof

7DVSKVF

- (1) Flat Flashing
- and all of the other Vertical Termination parts.

Twist Lock 12" Straight Pipe (CG)

7TFSDVP12

- (1) 12" Non-adjustable Pipe

Twist Lock 12"-18" Straight Pipe (CG)

7TFSDVP1218

- (1) 12" - 18" Adjustable Pipe

Twist Lock 24" Straight Pipe (CG)

7TFSDVP24

- (1) 24" Non-adjustable Pipe

Twist Lock 48" Straight Pipe (CG)

7TFSDVP48

- (1) 48" Nonadjustable Pipe

Twist Lock 45-Degree Elbow (CG)

7TFSDVT45

- for vertical offsets
- (1) 45-degree Elbow

Combination Offset/Roof Support

7DVCS

Attic Insulation Shield

7DVAIS

7" Charcoal Gray Pipe Rings, (4)

7FSDRG

7" Polished Brass Pipe Rings (4)

7FSDRP

Use the following approved CFM/Majestic vent components for fireplace installations vented through a masonry chimney:

7TFSCSK

Transition Connector

HEDV25

25-foot flex connector
(two 25 foot sections)

HEDV35

35-foot flex connector
(two 35 foot sections)

HEDV32T812

Vent termination for 8 x 12" flue

HEDV32T1212

Vent termination for 12 x 12" flue

HEDVT

Round termination

Installation

Unpack the Stove

The stove is shipped fully assembled on its back. Unpack the stove and carefully set it upright.

CAUTION

Porcelain enamelled surfaces are fragile. Handle porcelain enamelled castings tenderly. Familiarize yourself with the assembly steps before you begin and proceed with deliberation and care. If possible, have assistance available.

Place enamelled castings on a soft, cushioned surface until you are ready to assemble.

Avoid contact between the castings and other hard surfaces or objects.

NOTE: Verify the two relief doors (located on top of the firebox) are properly seated on the gasket. The doors sit flush on the gasket, and should lift easily from the seal around the opening.

If you are not installing a fan, proceed to the appropriate vent assembly section.

Install Optional Fan Kit #2960/FK28

Fan Kit Contents:

- #10 x 1/2" phillips screws, 6
- Control Knob
- Retainer Collar
- Snapstat
- Snapstat Bracket
- Blower Assembly w/ Rheostat Control

NOTE: The Rheostat Assembly and the Snapstat Assembly are not used on RF Models.

For RF Models only: Follow Step 3, then run the spliced female leads to the front of the stove and attach to PC board of RF valve. Then follow Step 5.

1. Attach the Snapstat to the Bracket using two #10 x 1/2" phillips sheet metal screws as shown in Figure 12.
2. Locate and remove the 1/4-20 x 3/8" hex head bolt installed in the hole in the right rear ledge of the firebox. (Fig. 11) Use that bolt to secure the Snapstat Bracket to the firebox. The mounting hole is slotted to allow you to adjust the bracket so that its head makes contact with the firebox surface. (Fig. 11)
3. Attach the Fan to the firebox by engaging the upper flange of the fan skirt under the lower edge of the Shroud and secure the skirt with the four screws provided with the kit. (Figs. 12, 13)

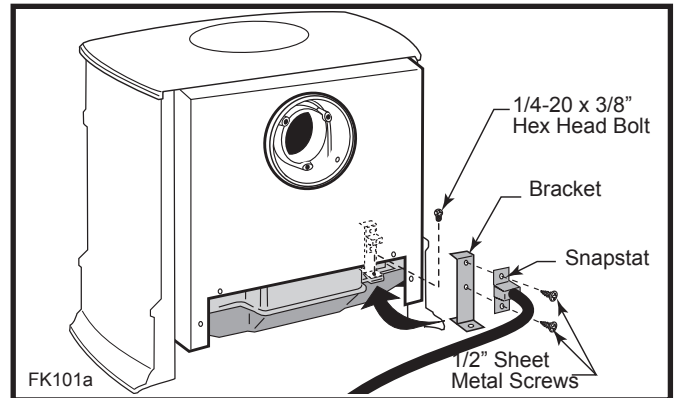

Fig. 11 Snapstat assembly and installation.

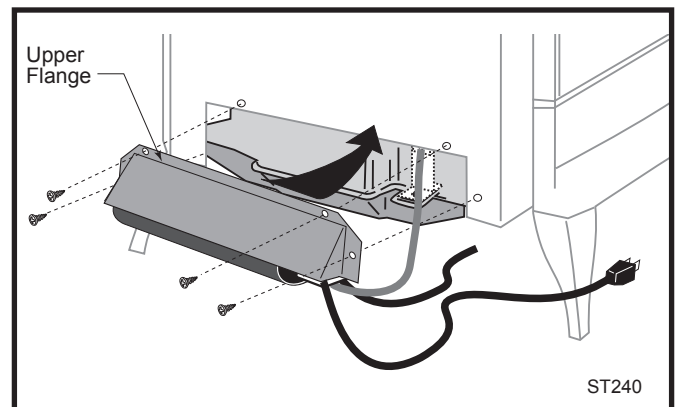

Fig. 12 The upper flange of the fan skirt should be located behind the lower edge of the shroud.

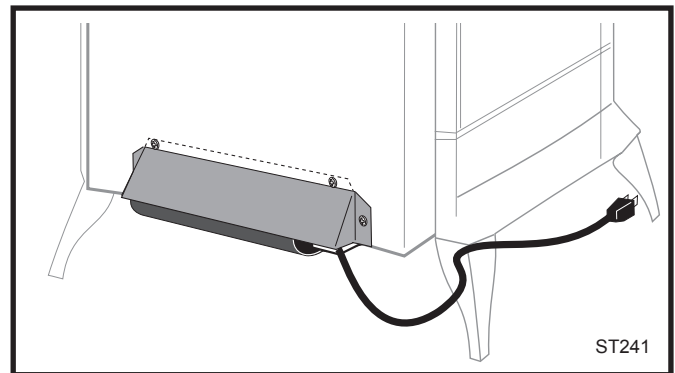

Fig. 13 Correct position of fan skirt installation.

4. The rheostat control switch attaches to the left side of the valve bracket at the front of the stove. (Fig. 14)
 - Insert the switch box shaft through the hole in the back of the right side of the valve bracket, aligning the locator pin with the smaller hole in that bracket.
 - Attach the retaining nut to the switch control shaft to secure it to the plate.
 - Attach the Control Knob to the rheostat shaft.
 - Use the wire tie to secure the fan and rheostat wire harnesses together.

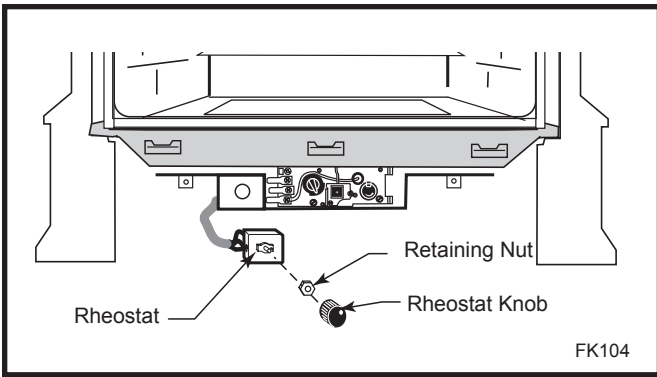

Fig. 14 Attach rheostat to bracket.

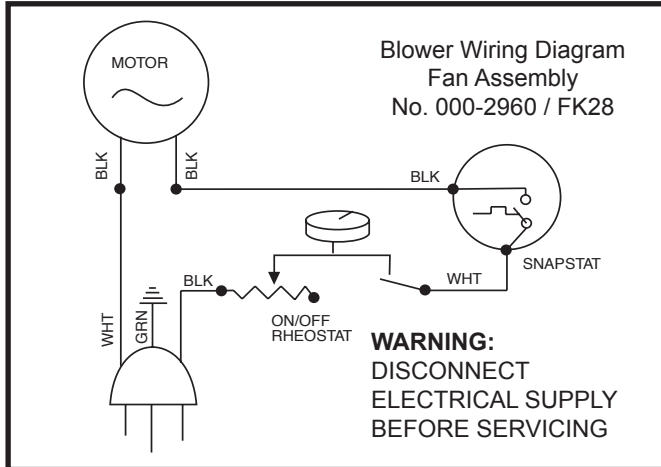

Fig. 15 Blower wiring diagram.

Venting System Assembly - Direct Vent

General Information

The PDV20 and SDVR are approved for installation only with the vent components listed on Page 13. Follow the vent component instructions exactly. These instructions apply to both the PDV20 and the SDVR shell.

For U.S. installations: The venting system must conform with local codes and/or the current National Fuel Gas Code, ANSI Z223.1/NFPA 54

For Canadian installations: The venting system must conform to the current CSA B149.1 installation code.

Rear Vent

Use Rear Vent Kit 7TFERSK for an installation where the heater is parallel to the wall and the vent system extends straight back through that wall.

1. Attach Inner Starter Pipe, (found in with the logset), to the stove.
 - Run a bead of sealant beneath the pipe bead and attach to the stove using three 1/4-20 x 3/8" phillips screws provided in the parts bag. (Fig. 16)
2. Locate the vent opening on the wall. Refer to Figures 17, 18 & 19 to determine the top of the opening

centerline. It may be necessary to first position the stove and measure to find the hole location. Depending on whether the wall is made of combustible materials, cut the opening to the size shown in Figure 17. Combustible wall openings must be framed as shown in Figure 17.

3. Measure the wall thickness and cut the wall sleeve sections to proper length (MAXIMUM 12"). Assemble

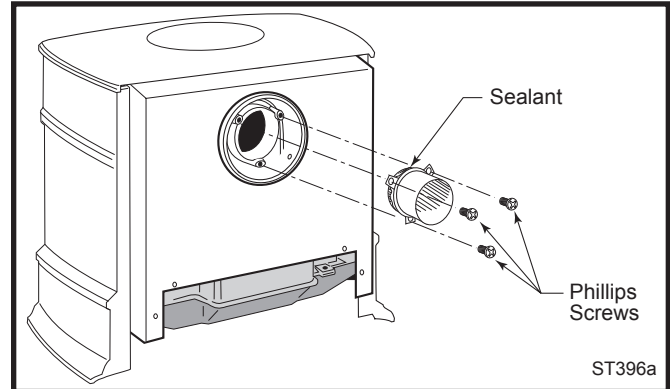

Fig. 16 Apply sealant to the starter pipe, and fasten to stove with Phillips screws.

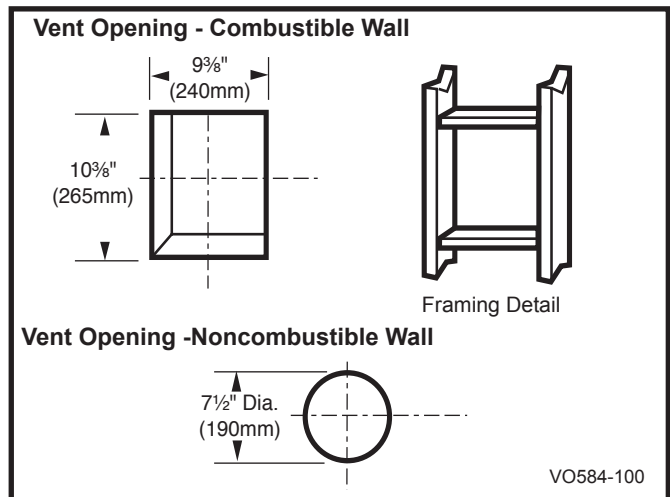

Fig. 17 Locate vent opening.

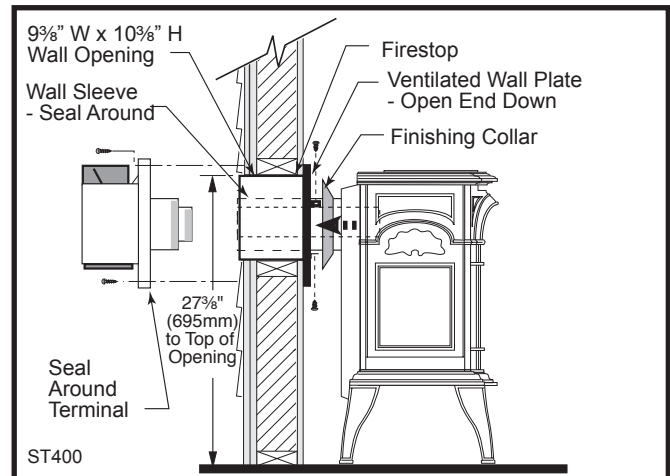

Fig. 18 SDVR with Rear Vent Kit 7TFERSK installation.

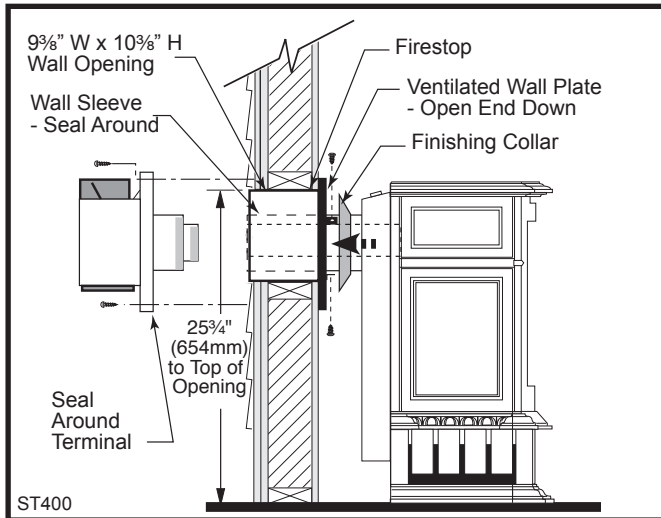

Fig. 19 PDV20 with Rear Vent Kit 7TFSRSK installation.

the sleeve with the #8 sheet metal screws supplied. Attach the firestop plate to the sleeve end with the holes. (Fig. 25) **NOTE:** The wall sleeve is required in combustible walls only.

4. Install the Wall Firestop/Sleeve assembly into the wall cutout and fasten the firestop to the wall cutout framing members. (Figs. 18, 19)
5. Measure, and cut if necessary, the appropriate length of pipe section needed to make the connection through the wall.
6. Slip the wall plate and trim collar over the interior end of the horizontal pipe and install into the wall sleeve. Seal the joint inside the wall plate if needed to keep cold air from being drawn into the home.
7. Connect the pipe to the inner collar. Fasten the wall plate to the pipe with three sheet metal screws. Slide the trim collar up against the wall plate to cover the screws. (Figs. 18, 19)
8. Install the vent terminal. (Figs. 18, 19) Guide the inner and outer vent termination collars into the adjacent pipes. Double check that the vent pipes overlap the collars by 2". Fasten the termination to the wall with the screws provided, and caulk the joint with weatherproof sealant.

Through Side Wall / Vent Termination Below Grade

Refer to Figures 20 & 21 for minimum centerline of wall opening.

1. Attach Inner Starter Pipe, (found in with the logset), to the stove.
 - Run a bead of sealant beneath the pipe bead and attach to the stove using three 1/4-20 x 3/8" phillips screws provided in the parts bag. (Fig. 22)
2. Dry fit the inner and outer pipe of the first elbow directly to the starter pipe.

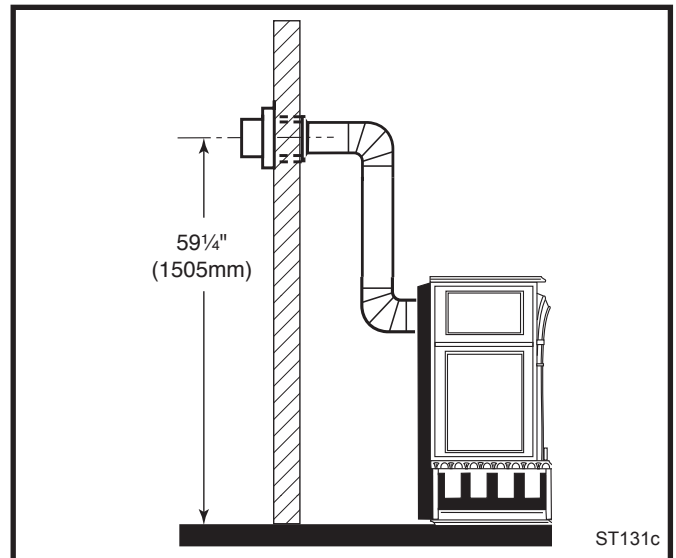

Fig. 20 Minimum wall thimble centerline.

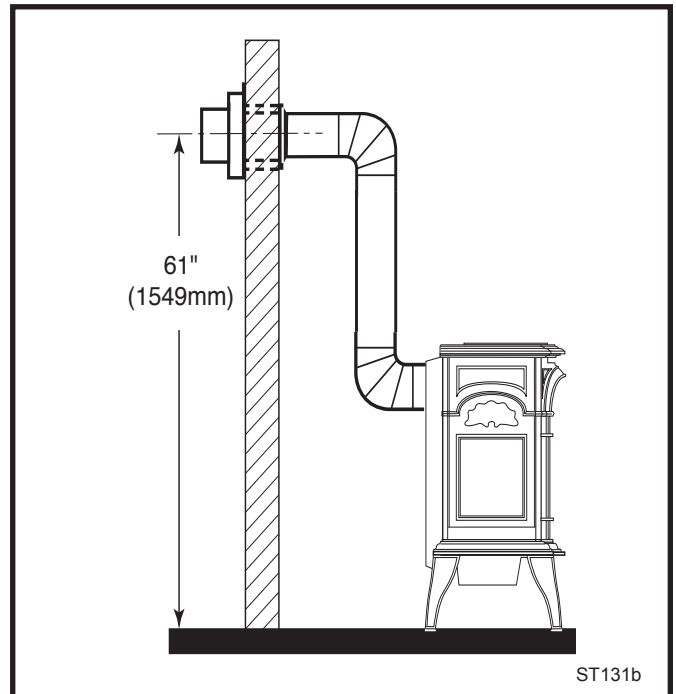

Fig. 21 Minimum wall thimble centerline.

3. Dry fit the Inner pipe assembly to the stove for the purpose of determining the center line of the pipe on the wall.
 - Side Wall Terminations: Dry fit the outer elbow with the vertical outer vent and confirm the centerline alignment with the wall thimble opening.
4. Attach the elbow to the starter pipe.
 - Run a bead of sealant about 1/2" from end of the starter pipe and attach the assembly to the stove using three 1/4-20 x 3/8" Phillips screws provided in the parts bag. (Fig. 22)

5. Install the first elbow and secure using three sheet metal screws. Insert the elbow over the stove flue collar. Also, be sure to align holes on the pipe with the holes on the flue collar of the firebox. Fasten the pipe to the holes in the flue collar with the #12 x 1/2" sheet metal screws provided. (Fig. 23)

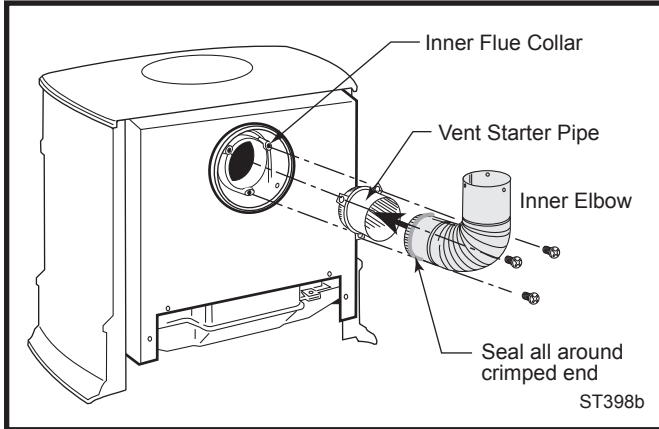

Fig. 22 Install inner starter pipe and inner elbow.

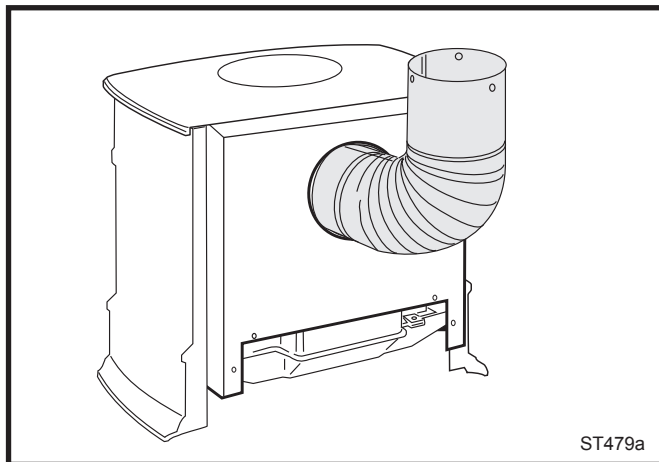

Fig. 23 Fasten outer pipe with #12 x 1/2" sheet metal screws.

Side Wall Termination Assembly

1. Locate the vent opening on the wall. Refer to Figures 20 & 21, to determine the minimum centerline of wall opening. It may be necessary to first position the stove and measure to find the hole location. Depending on whether the wall is made of combustible materials, cut the opening to the size shown in Figure 24. Combustible wall openings must be framed as shown in Figure 24.

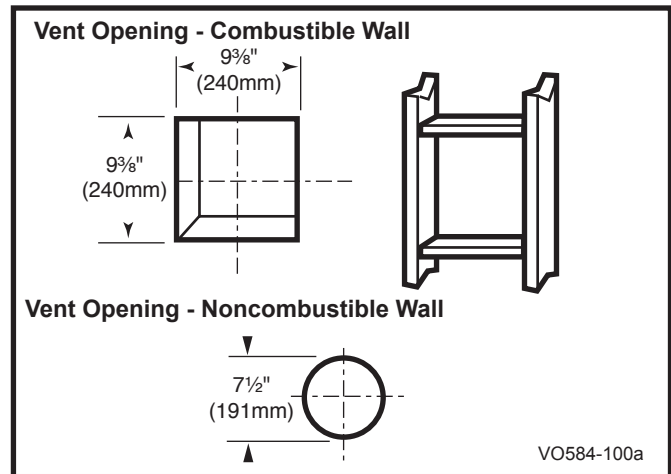

Fig. 24 Locate vent opening.

2. Measure the wall thickness and cut the wall sleeve sections to proper length (MAXIMUM 12"). Assemble the sleeve with the #8 sheet metal screws supplied. Attach the firestop plate to the sleeve end with the holes. (Fig. 25) **NOTE:** The wall sleeve is required in combustible walls only.
3. Install the Wall Firestop/Sleeve assembly into the wall cutout and fasten the firestop to the wall cutout framing members. (Fig. 25)

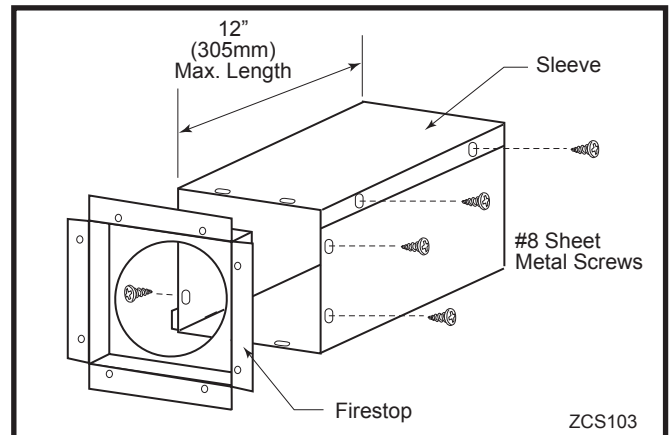

Fig. 25 Assemble the wall sleeve and firestop.

4. If necessary, measure to determine the vertical length (X) of pipe required from the first (transition) elbow to the wall cutout centerline, including a 2" overlap at the joint. (Fig. 26) Use a hacksaw or tin snips to trim the pipe as needed.
5. Install first the inner then the outer straight pipe section(s), trimmed end down, to the point of the elbow. Drill 3 holes through each joint and fasten with sheet metal screws.
6. Install the elbow using 3 sheet metal screws at each joint.
7. Measure, and cut if necessary, the appropriate length of pipe section needed to make the connection through the wall. Include a 2" overlap; i.e. from

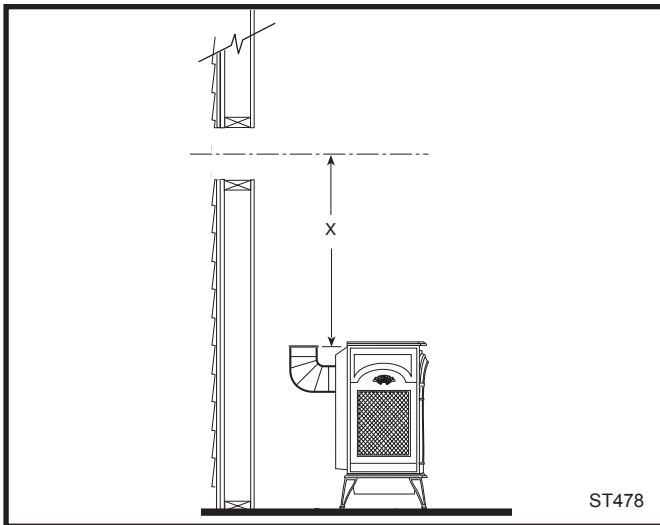

Fig. 26 Determine the vertical pipe length.

the elbow to the outside wall face, about 2" or the distance required if installing a second 90° elbow. (Fig. 27)

8. Slip the wall plate and trim collar over the interior end of the horizontal pipe and install into the wall sleeve. Seal the joint inside the wall plate if needed to keep cold air from being drawn into the home.

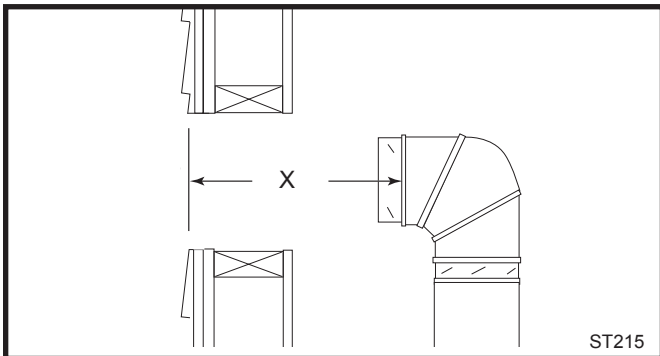

Fig. 27 Measure the horizontal length.

9. Connect the horizontal pipe to the elbow. Fasten the wall plate to the pipe with three sheet metal screws. Slide the trim collar up against the wall plate to cover the screws. (Fig. 28)
10. Install the vent terminal. (Fig. 29) Guide the inner and outer vent termination collars into the adjacent pipes. Double check that the vent pipes overlap the collars by 2". Fasten the termination to the wall with the screws provided, and caulk the joint with weatherproof sealant.
11. Install Charcoal Gray Pipe Rings (#7FSDRG) or Polished Brass Pipe Rings (#7FSDRP) at pipe joints, if desired.

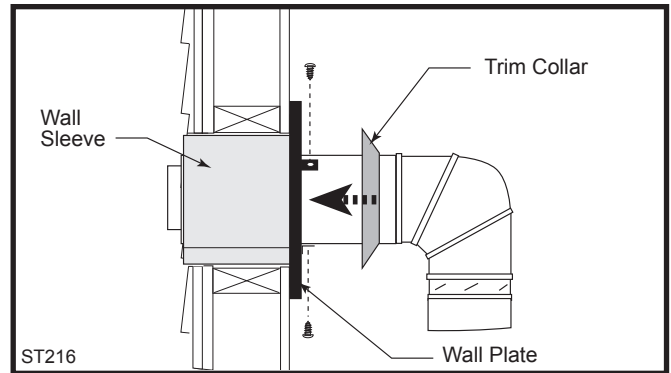

Fig. 28 Install the horizontal pipe and wall plate parts.

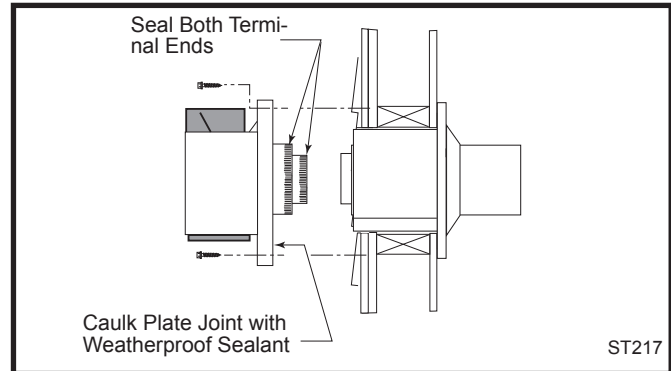

Fig. 29 Install the vent terminal.

Vent Termination Below Grade

Install Snorkel #7TDVSNORK when it is not possible to meet the required vent termination clearances of 12" (305mm) above grade level. The snorkel kit will allow installation depth of down to 7" (178mm) below grade level. The seven inches is measured from the center of the horizontal vent pipe as it penetrates the wall. **If the venting system is installed below grade, a window well must be installed with adequate and proper drainage.** (Fig. 30)

NOTE: Be sure to maintain side wall clearances and vent run restrictions. Refer to Figures 3 through 9.

1. Establish the vent hole through the wall.
2. Remove soil to a depth of approximately 16" (400mm) below the base of the snorkel. Install a window well (not supplied). Refill the hole with 12" (305mm) of coarse gravel and maintain a clearance of at least 4" (102mm) below the snorkel. (Fig. 30)
3. Install the vent system as described on Pages 14-17.
4. Be sure to make a watertight joint around the vent pipe joint at the inside and outside wall joints.
5. Apply high temperature sealant around the inner and outer snorkel collars. Join the pipes and fasten the snorkel termination to the wall with the screws provided.

- Level the soil to maintain a 4" clearance below the snorkel.

If the foundation is recessed, use extension brackets (not supplied) to fasten the lower portion of the snorkel. Fasten the brackets to the wall first, and then fasten to the snorkel with self-tapping #8 x 1/2" sheet metal screws. Extend the vent pipes out as far as the protruding wall face. (Fig. 31)

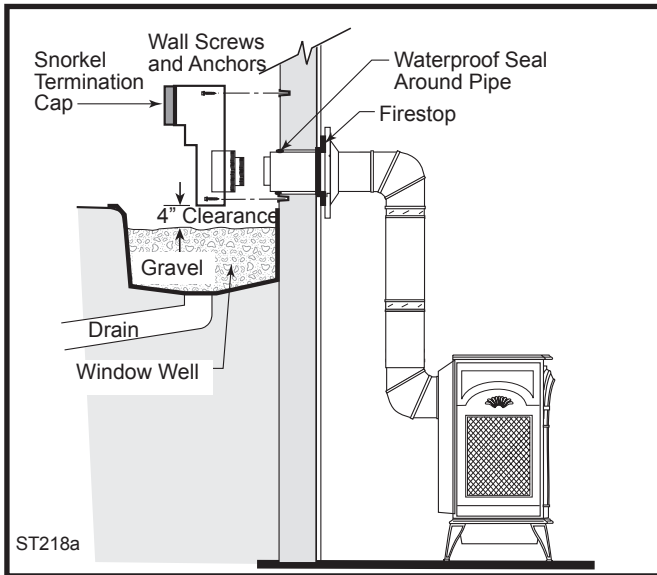

Fig. 30 Snorkel kit installation.

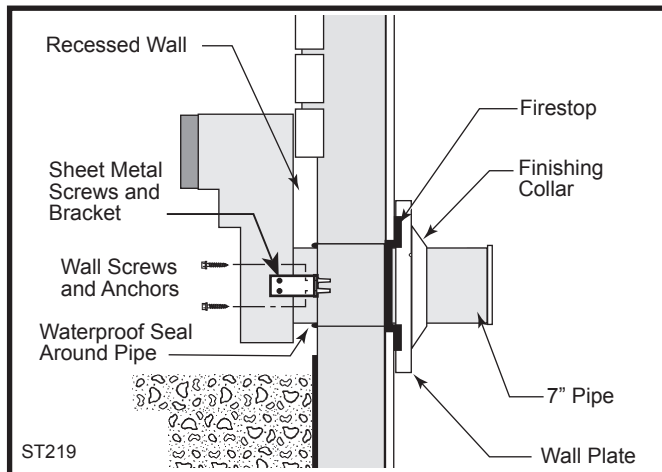

Fig. 31 Use extension brackets to mount snorkel against recessed wall.

Vertical (Through the Roof) Vent Assembly

NOTE: All vertically terminated installations must, where specified, use the 2¼" restrictor plate, to comply with Vertical Termination Window (Fig. 8, Page 8), included in the hardware bag. The plate must be installed within the firebox inner flue collar to insure a proper air/fuel ration is maintained in an appliance vented through the roof. (Fig. 32)

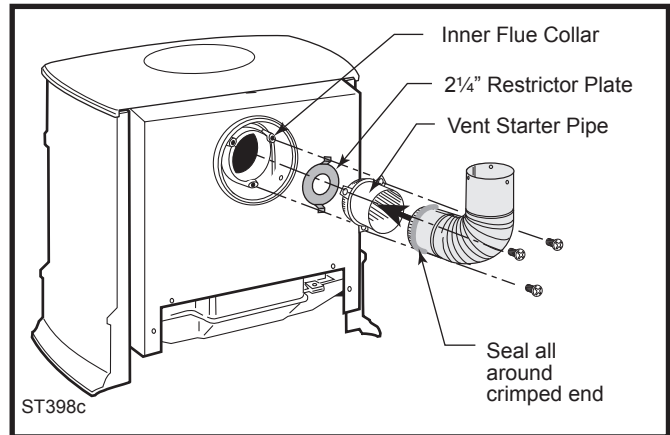

Fig. 32 Install restrictor plate and starter pipe/inner elbow assembly.

Make certain the vent system conforms to all other requirements for vertical termination as specified on Page 9.

This installation will require you to first determine the roof pitch and use the appropriate vent components. Refer to Page 10, Figure 9.

- Locate the final position of the stove, observing all clearances for both the vent and the stove.
- Plumb to the center of the inner (4") flue collar from the ceiling above, and mark that location.
- Cut the opening:** (Page 17, Fig. 24)
9³/₈" x 9³/₈" (240 x 240mm)
- Plumb any additional opening through the roof or other construction that may be needed. In all cases, the opening must provide a minimum of 1" (25mm) clearance to the vent pipe.
- Place the stove in its final position.
- Install firestop(s) #7DVFS and Attic Insulation Shield #7DVAIS as needed. (Fig. 33) If there is a room above ceiling level, a firestop must be installed on both the bottom and top sides of the ceiling joists. If an attic is above ceiling level, an attic insulation shield must be installed.
- Install the appropriate roof support and flashing, making certain that the upper flange of the flashing base is below the shingles. (Fig. 34)

8. Install appropriate pipe sections until the vent run reaches above the flashing. The enlarged ends of the vent sections always face downward.
9. Install the storm collar and seal around the joints. (Fig. 34)
10. Add additional vent lengths to achieve the proper overall height.
11. Install termination cap.

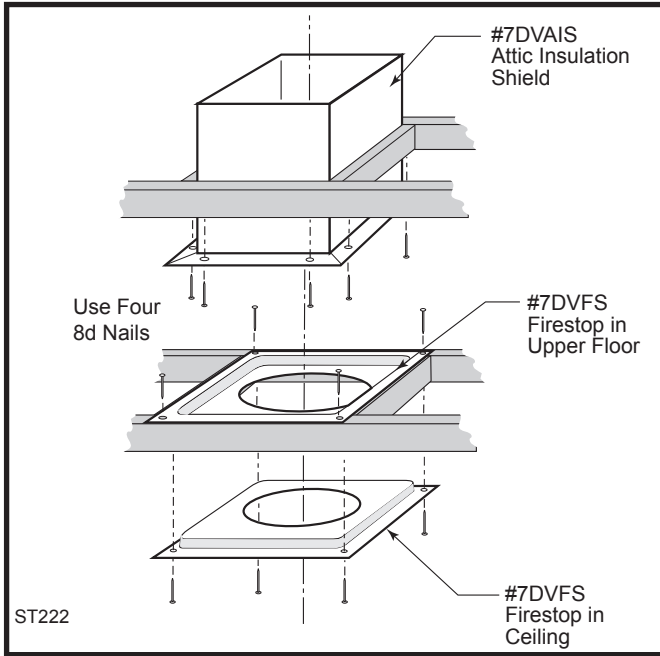

Fig. 33 Install firestops and attic insulation shield.

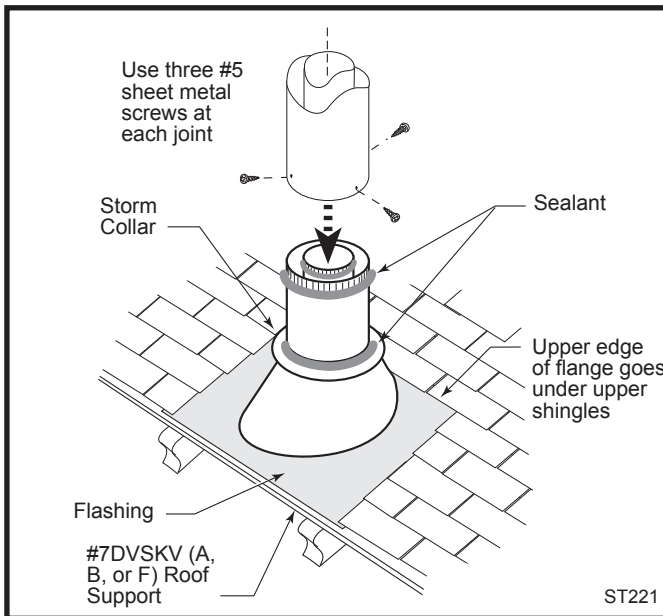

Fig. 34 Roof support and flashing.

Vertical Through Existing Chimney

The heater must be vented to the outdoors through an existing masonry or prefabricated fireplace chimney system through the roof.

The heater is approved to be vented to the outdoors through any solid-fuel fireplace chimney that has been constructed or installed in accordance with the national, Provincial/State and local building codes and is constructed of noncombustible materials. For Venting Requirements, refer to Page 10. Refer to Venting Components on Page 12.

Fireplace Vent Termination Clearances

Observe the chimney-top vent termination clearances specified in the instructions provided with those components. Some considerations are:

- Obstructions or impediments to venting.
- Nearby combustible materials that could come into contact with combustion exhaust gases.
- Other nearby openings (within 9" (230mm) through which exhaust gas could reenter the building.
- All vegetation within 36" (914mm) that may interfere with the draft.

NOTE: The collar extending down from the Termination base is the air intake collar. Use the flex vent liner, marked with a **blue line**, to connect between this collar and the lower flue collar on the Transition Connector. Also make sure the other flex vent liner is attached to the upper Transition Connector collar and the Rain Cap. (Fig. 35)

1. Clean the top of the chimney as needed, to ensure a good seal between it and the vent termination.
2. Slide the insulation sleeves provided in the termination kit over the two 3" flex liners (to be attached to the 3" flue collar and cap of the termination assembly).
3. Feed 3" flex vent from the bottom of the termination assembly up through the 4" sleeve. Apply high-temperature sealant to the rain cap collar, and slide the flex vent over the end of the rain cap collar, fastening with the clamp provided.
4. Slide the flex liner back through the 4" sleeve until the rain cap/collar engages over the sleeve. Attach the cap to the sleeve with three sheet metal screws provided in the kit.
5. Apply high-temperature sealant over the air intake collar, and attach the intake flex vent (blue) with a clamp.
6. Apply high-temperature sealant to the top of the chimney. Feed the two liners down through the chimney flue and damper opening. Fasten the termination assembly to the chimney with the four set screws (C) provided.

7. Trim the flex liners as needed. Each should be only long enough to connect to the Transition Connector. There should be no sag in either flex liner when the stove is in place.
8. Attach the flex liners to the Transition Connector, using high-temperature sealant and clamps as shown in Figure 35. Prop the connector in rough position until the heater is in place in front of it.

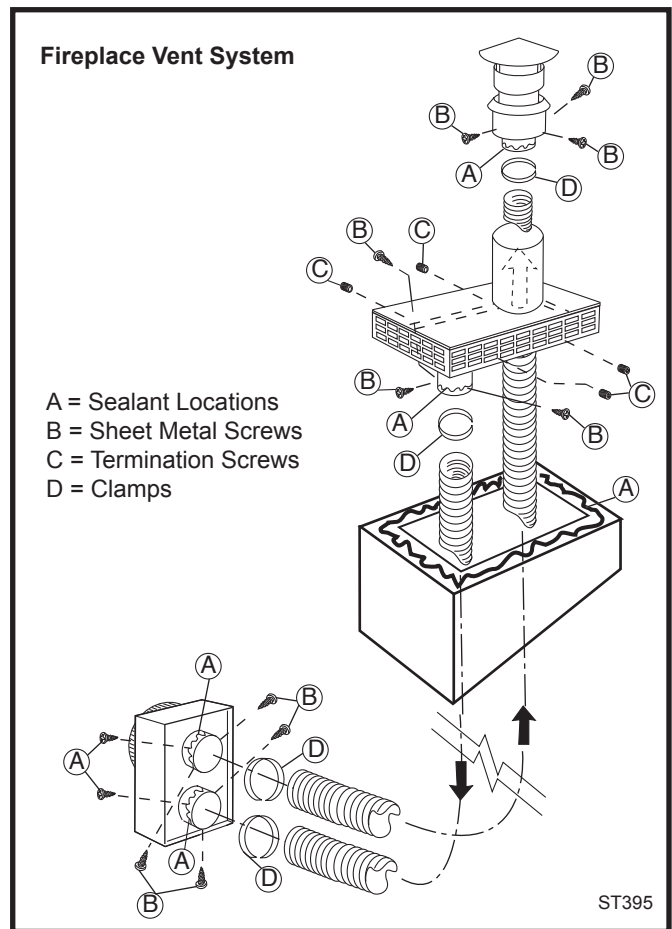

Fig. 35 Fireplace vent system installation.

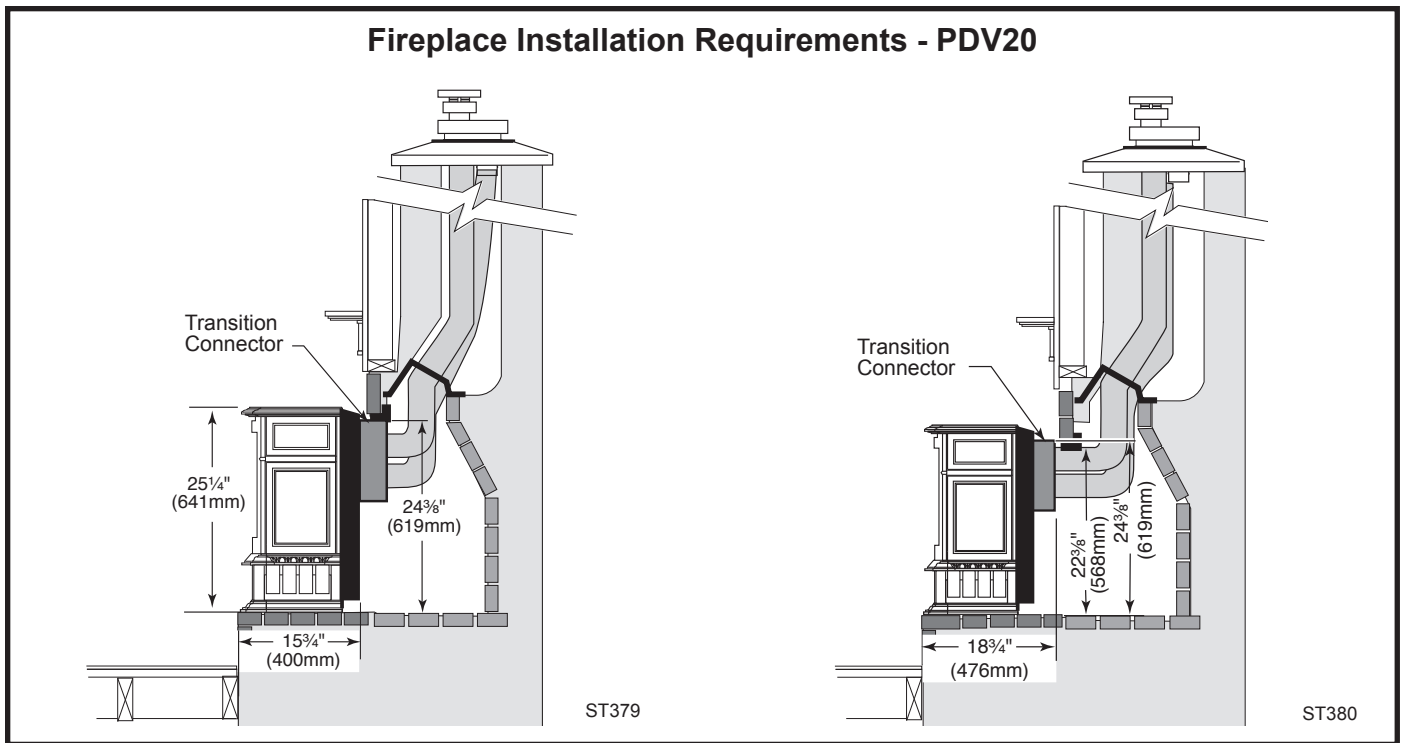

Fig. 36 PDV20 minimum lintel height for flush or forward placement.

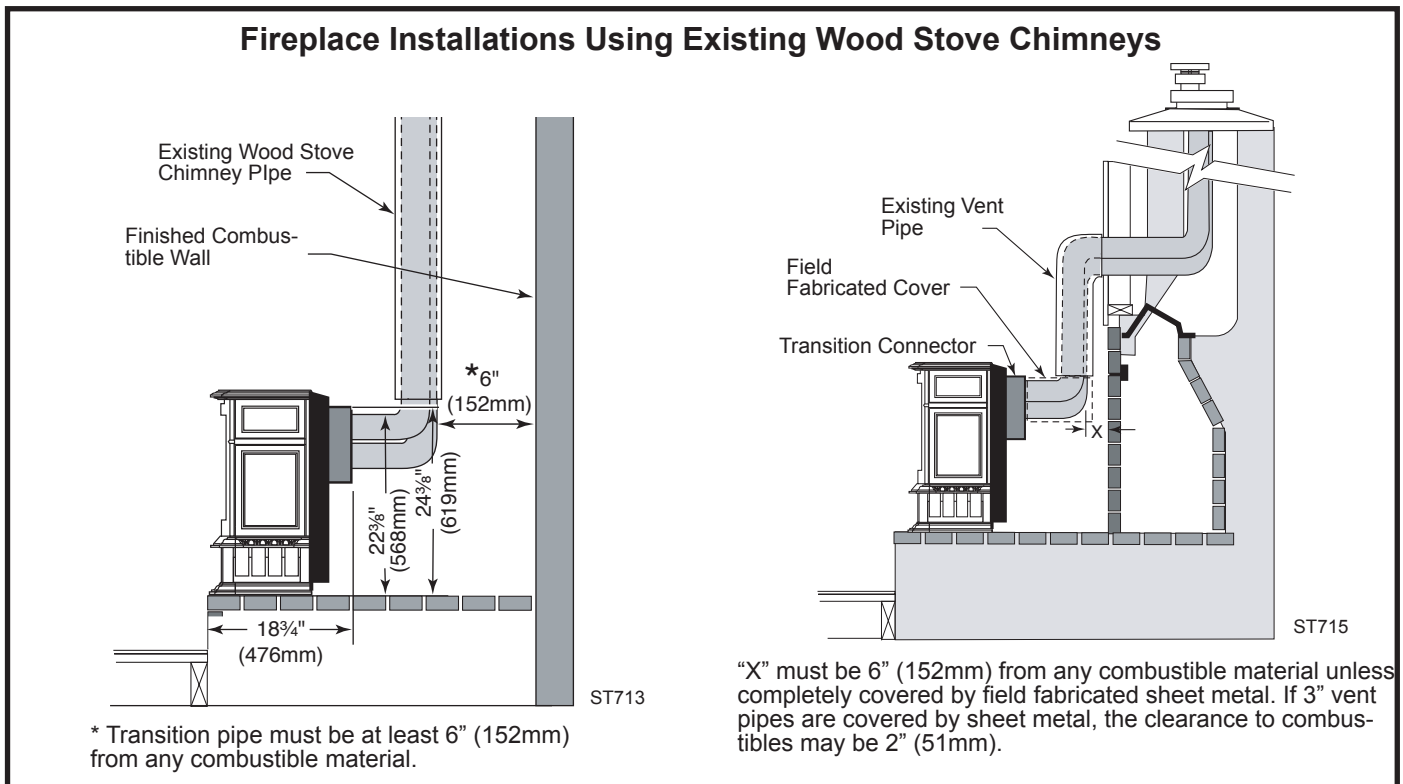

Fig. 37 PDV20 installations using existing wood stove chimney pipe.

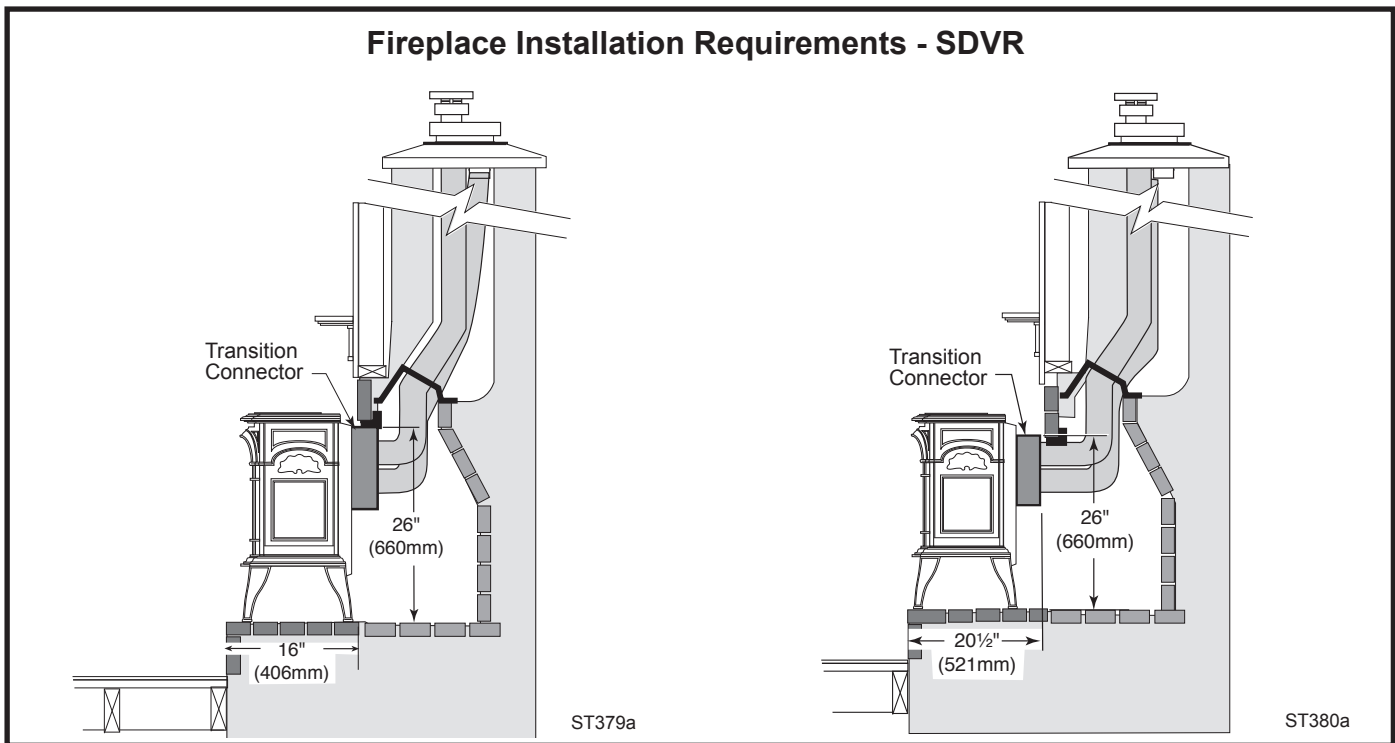

Fig. 38 SDVR minimum lintel height for flush or forward placement.

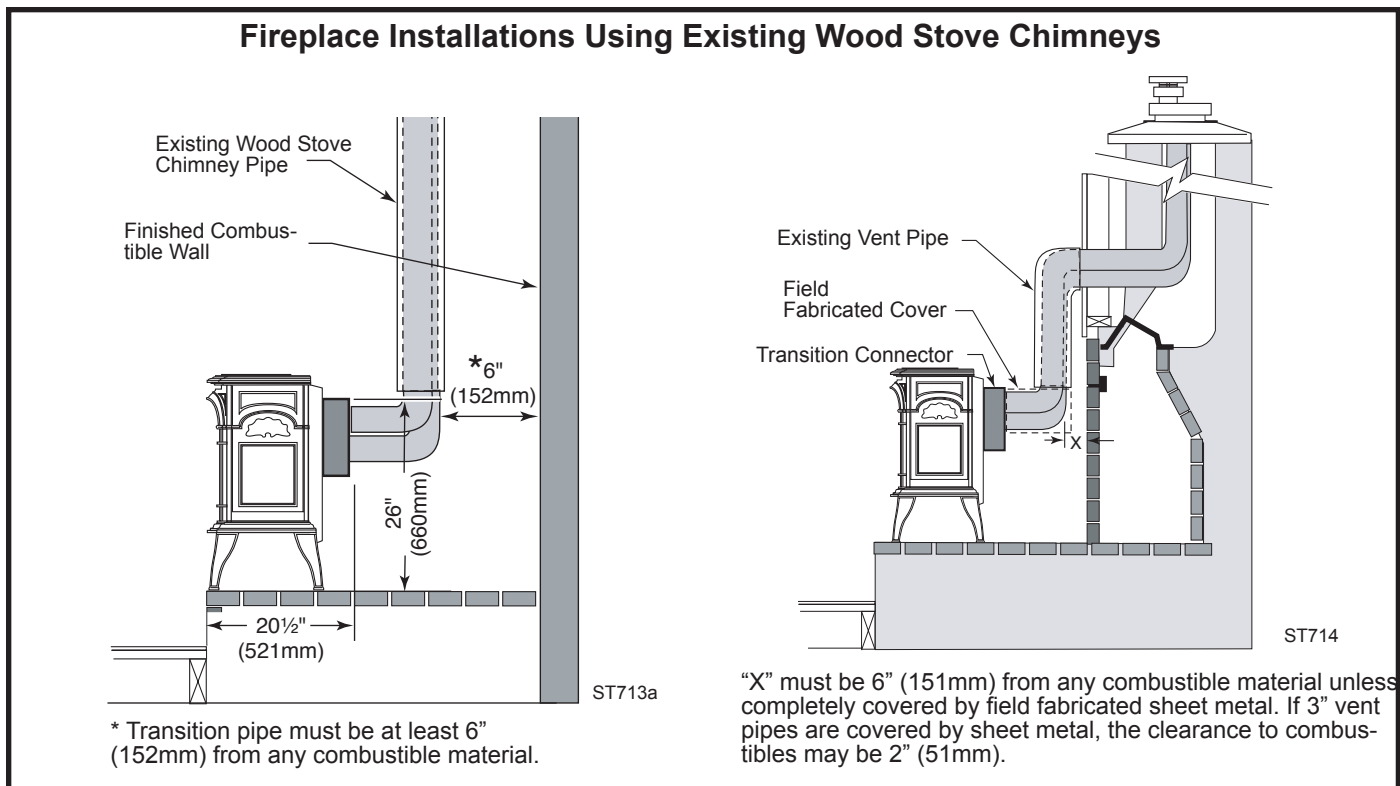

Fig. 39 SDVR installations using existing wood stove chimney pipe.

Connect the Gas Supply Line

Check the rating plate attached by a steel cable to the firebox, to confirm that you have the appropriate firebox for the type of fuel to be used. The PDV20 and SDVR may be converted from one gas to another using the appropriate Fuel Conversion Kit listed on Page 41.

CAUTION



This appliance should only be connected by a qualified gas technician. Test to confirm manifold pressures as specified below.

The PDV20 and SDVR Heaters and the individual shutoff valves must be disconnected from the gas supply piping during any pressure testing of that system at test pressures in excess of 1/2 psig (3.5 kPa).

The PDV20 and SDVR Heaters must be isolated from the gas supply piping system by closing the individual manual shutoff valve during any pressure testing of the gas supply piping system at test pressure equal to or less than 1/2 psig.

There must be a gas shutoff between the stove and the supply.

In order to connect Natural Gas, use a fitting with 3/8" NPT nipple on the valve side and 1/2" natural gas supply line with an input of 21,000 BTUs at a manifold pressure of 3.5" and minimum inlet supply for adjustment of 5.5" w.c.

In order to connect Propane, use a fitting with 3/8" NPT nipple on the valve side and 1/2" propane gas supply line with an input of 21,000 BTUs at a manifold pressure of 10.0" and minimum inlet supply for adjustment of 11.0" w.c.

In the U.S.: Gas connection should be made in accordance with current National Fuel Gas Code, ANSI Z223.1/NFPA 54. Since some municipalities have additional local codes, be sure to consult your local authority.

In Canada: consult the local authority and CSA-B149.1 installation code.

Connect the gas supply and test for leaks. Use a mild soap and water solution applied with a brush no larger than 1" (25mm). Never apply soap and water solution with a spray bottle. Do not use an open flame for leak testing.

Burner Information

The appliance must only use the gas specified on the rating plate, unless converted using a Vermont Castings Fuel Conversion Kit. Refer to Page 41 for correct Fuel Conversion Kit for your stove model.

Conversion instructions are provided with each kit and beginning on Page 33 of this manual.

THIS APPLIANCE SHOULD BE CONNECTED TO THE GAS SUPPLY ONLY BY A QUALIFIED GAS SERVICE TECHNICIAN. FOLLOW ALL LOCAL CODES. THERE MUST BE A GAS SHUT-OFF BETWEEN THE STOVE AND THE SUPPLY.

In order to connect Natural Gas, use a fitting with a 3/8" NPT nipple on the valve side and 1/2" natural gas supply line with an input of 21,000 BTU's at a manifold pressure of 3.5" and minimum inlet supply for adjustment of 5.5" w.c.

In order to connect Propane, use a fitting with 3/8" NPT nipple on the valve side and 1/2" propane gas supply line with an input of 21,000 BTUs at a manifold pressure of 10.0" and minimum inlet supply for adjustment of 11.0" w.c.

Complete the Assembly

- Open the swiveling latches (cams) on the top left and right corners of the glass frame.
- Position the glass and frame against the firebox by placing the bottom edge on the brackets on the bottom face of the firebox.
- Swing the assembly against the firebox, and close the latches firmly against the pins protruding from the firebox top.

Install ON/OFF Switch (R Models ONLY)

The switch assembly parts are found in the parts bag.

1. Attach switch assembly to left rear side of stove shroud using two screws and existing holes in shroud. (Fig. 40)
2. Run wires down back of stove, under bottom of rear shroud to valve.
3. Attach wires to valve terminals. (Fig. 41)

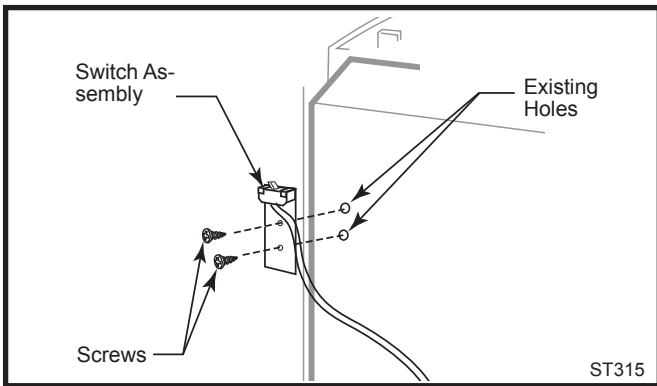

Fig. 40 Attach switch assembly to rear shroud.

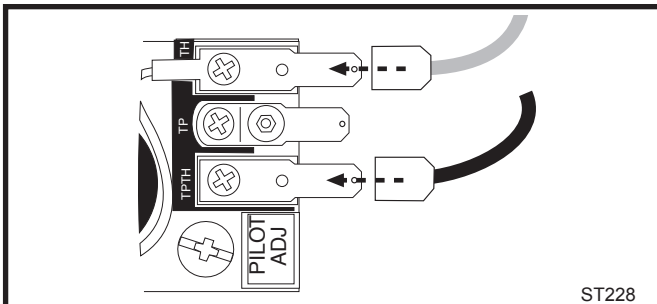

Fig. 41 Attach switch wires to valve.

Install the Front Plate

Grasp the Front Plate and lift it into position, engaging the two steel tabs at the upper corners behind the adjacent bosses in the Side Plates. (Fig. 42) Seat the Front against the Sides so that the tabs at the bottom lip engage with the notches in the edge of the stove base. When properly installed, the bottom of the Front Plate cannot be pulled away from the sides without also lifting it up.

If you are installing optional Warming Shelves, do so now, according to the instructions supplied with that kit.

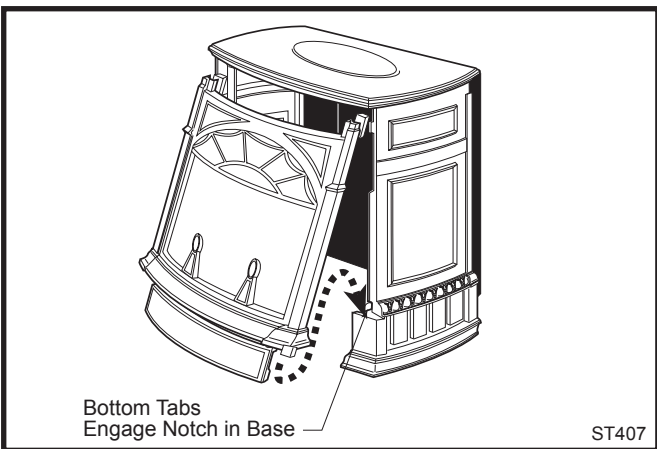

Fig. 42 Install Stove Front.

Thermostat Connection (Optional) R Models Only

Use only a thermostat rated for 500 - 750 millivolts. Check the table below for the appropriate gauge thermostat wire to use for the length of lead required in your installation.

Thermostat Wire / Gauge	Maximum Run
18	40 feet
20	25 feet
22	16 feet

1. Install the wall thermostat in the desired location and run the wires to the stove location. Terminate these leads with 1/4" female connectors.
 2. Connect the thermostat wires to the valve. (Fig. 41)
- This completes assembly of the PDV20 and SDVR stove.**

Install the Log Set

Remove the logs from their packaging, and inspect each piece for damage. **DO NOT INSTALL DAMAGED LOGS.**

1. Install the rear log by centering it side to side on the sheet metal shelf at the back of the firebox. (Fig. 43) The log will touch both sides and back wall of the firebox.
2. Install the right log by placing right side of log on burner so it is just touching firebox side. Lay log flat on burner almost touching the decorative grate. Then tilt log back so that it leans against rear log. (Fig. 43) Only the topmost part of the left side of log will touch the rear log. The right log sits freely on the burner and does not use locator pins to stay in place.
3. Place left log on burner, making sure to engage locator pins in holes in bottom of the log. (Fig. 43) This log does not touch any other log.
4. Sprinkle lava rock on burner in front of, and between, left and right logs. (Fig. 44)

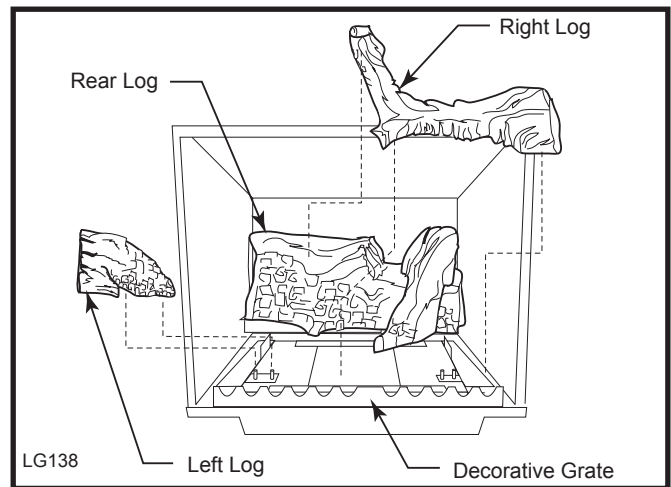

Fig. 43 Install back, right and left logs.

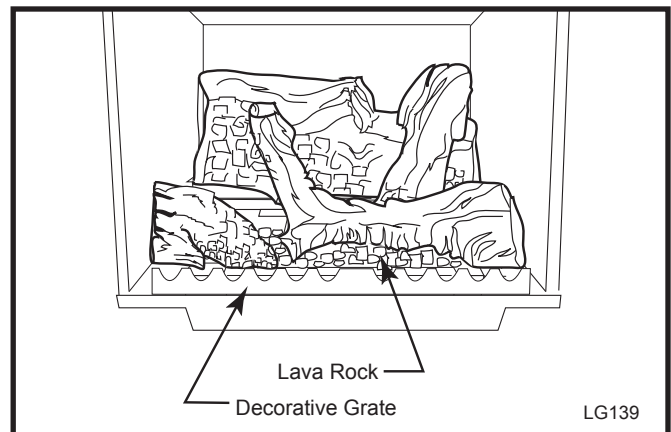

Fig. 44 Place lava rock on burner.

Operation

The Stardance is operated with the operable door front plate in place with the doors open or closed. To open the front doors, insert the handle into the door latch stub and turn it to the left and up. (Fig. 45) When not in use, the handle may be stored in the handle holder on the right side of the rear shroud. (Fig. 46)

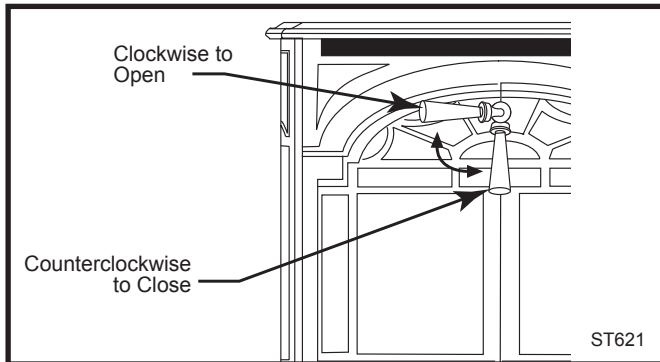

Fig. 45 To open the front doors, turn handle clockwise.

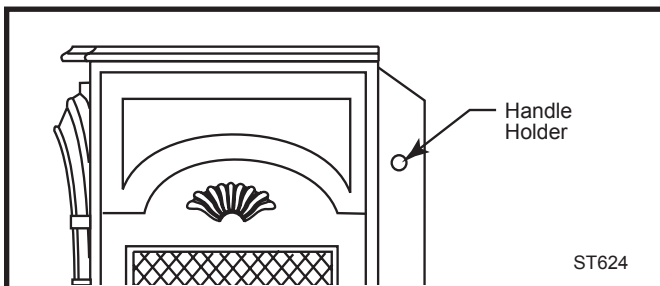

Fig. 46 When not in use, store handle in the handle holder.

Your First Fire

Read these instructions carefully and familiarize yourself with the burner controls shown in Figure 47. Locate the pilot assembly, Figure 48. Follow the lighting instructions on Page 28 exactly.

During the first fire, it is not unusual to smell some odor associated with new logs, paint and metal being heated. Odors should dissipate within a few hours. You can open a window to provide fresh air to alleviate the condition.

Pilot and Burner Inspection

Each time you light your heater check that the pilot flame and burner flame pattern are as shown in Figures 50 through 52. If flame patterns are incorrect, turn the heater off. Contact your dealer or a qualified gas technician for assistance. Do not operate the heater until the pilot flame is correct.

Follow regular maintenance procedures as described on Page 36.

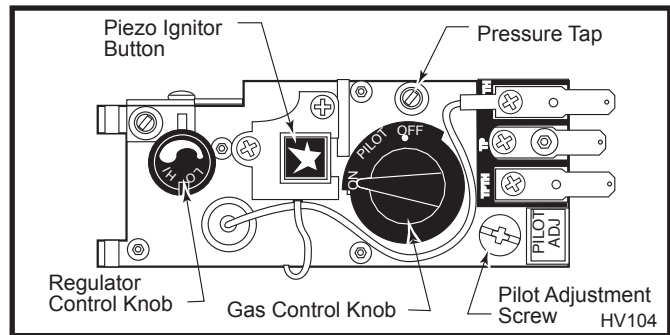

Fig. 47 RN & RP valve control.

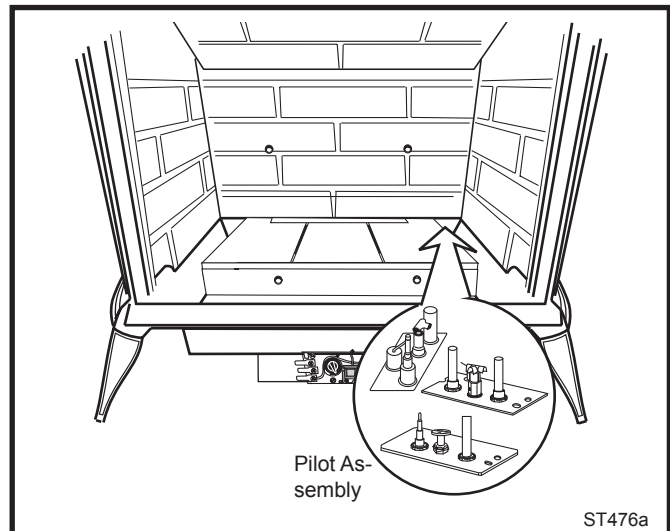

Fig. 48 Pilot Assembly location.

Flame & Temperature Adjustment

For stoves equipped with HI/LO valves, flame adjustment is accomplished by rotating the HI/LO adjustment knob located near the center of the gas control valve. (Fig. 49)



Fig. 49 Flame adjustment knob for Honeywell valve.

Flame Characteristics

It is important to periodically perform a visual check of the pilot and the burner flames. Compare them to Figures 50 through 52.

If any of the flames appear abnormal call a service person.

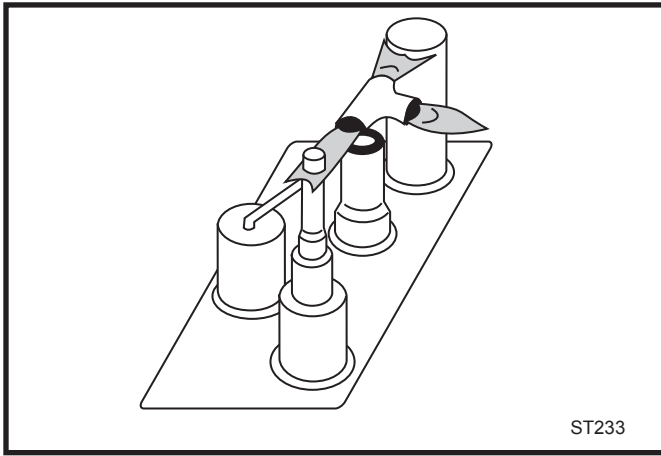

Fig. 50 Correct pilot flame pattern. PSE Pilot.

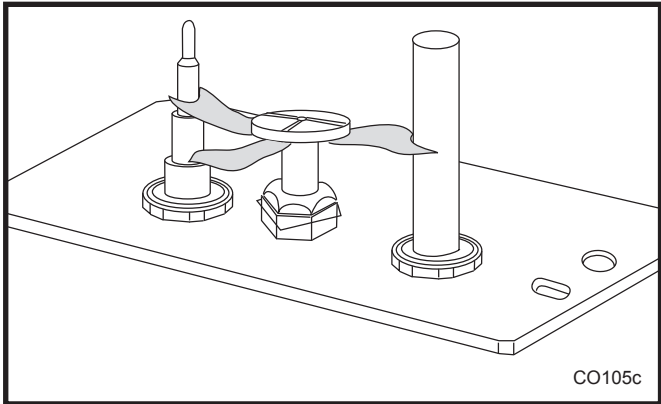

Fig. 51 Correct pilot flame pattern. SIT pilot.

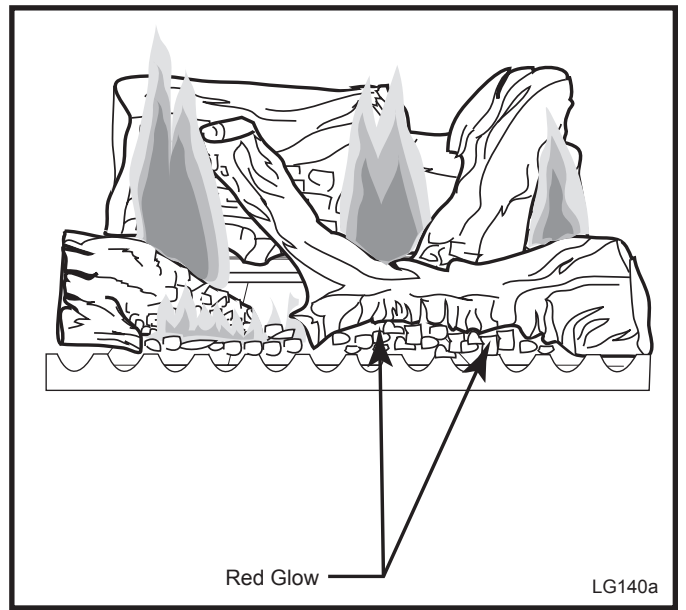

Fig. 52 Correct burner flame pattern.

Lighting And Operating Instructions

FOR YOUR SAFETY READ BEFORE LIGHTING

WARNING: If you do not follow these instructions exactly, a fire or explosion may result causing property damage, personal injury or loss of life.

- A. This heater has a pilot which must be lit manually. When lighting the pilot follow these instructions exactly.
 - B. BEFORE LIGHTING smell all around the heater area for gas. Be sure to smell next to the floor because some gas is heavier than air and will settle on the floor.
- WHAT TO DO IF YOU SMELL GAS**
- Do not try to light any fireplace
 - Do not touch any electric switch
 - Do not use any phone in your building
 - Immediately call your gas supplier from a neighbor's phone. Follow the gas supplier's instructions.
 - If you cannot reach your gas supplier, call the Fire Department
- C. Use only your hand to push in or turn the gas control knob. Never use tools. If the knob will not push in or turn by hand, do not try to repair it, call a qualified service technician. Applying force or any attempted repair may result in a fire or explosion.
 - D. Do not use this fireplace if any part has been under water. Immediately call a qualified service technician to inspect the heater and to replace any part of the control system and any gas control which has been under water.

Lighting Instructions

1. **STOP!** Read the safety information above.
2. Turn off all electrical power to the fireplace.
3. For MN/MP/TN/TP appliances ONLY, go on to Step 4. For RN/RP appliances turn the On/Off switch to "OFF" position or set thermostat to lowest level.
4. Open control access panel.
5. Push in gas control knob slightly and turn clockwise  to "OFF".



Euro SIT

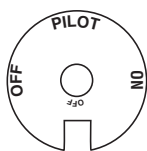

SIT NOVA

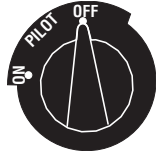

Honeywell

6. Wait five (5) minutes to clear out any gas. Then smell for gas, including near the floor. If you smell gas, STOP! Follow "B" in the safety information above. If you do not smell gas, go to the next step.
7. Remove glass door before lighting pilot. (See Glass Frame Removal section).
8. Visibly locate pilot by the main burner.
9. Turn knob on gas control counterclockwise  to "PILOT".

10. Push the control knob all the way in and hold. Immediately light the pilot by repeatedly depressing the piezo spark ignitor until a flame appears. Continue to hold the control knob in for about one (1) minute after the pilot is lit. Release knob and it will pop back up. Pilot should remain lit. If it goes out, repeat steps 5 through 8.

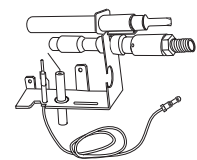
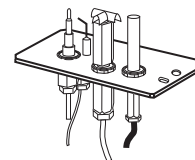
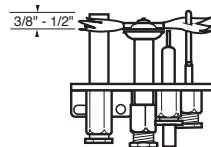

- If knob does not pop up when released, stop and immediately call your service technician or gas supplier.
 - If after several tries, the pilot will not stay lit, turn the gas control knob to "OFF" and call your service technician or gas supplier.
11. Replace glass door.
 12. Turn gas control knob to "ON" position.
 13. For RN/RP appliances turn the On/Off switch to "ON" position or set thermostat to desired setting.
 14. Turn on all electrical power to the fireplace.

To Turn Off Gas To Heater

1. Turn the On/Off switch to Off position or set the thermostat to lowest setting.
2. Turn off all electric power to the fireplace if service is to be performed.
3. Open control access panel.
4. Push in gas control knob slightly and turn clockwise  to "OFF". Do not force.
5. Close control access panel.

Troubleshooting / Honeywell #8420 Gas Control System

NOTE: Before troubleshooting the gas control system, be sure the external gas shutoff is in the "ON" position.

WARNING: REMOVE THE GLASS PANEL BEFORE PERFORMING ANY GAS CONTROL SERVICE WORK.

SYMPTOM	POSSIBLE CAUSES	CORRECTIVE ACTION
1. Spark ignitor will not light	A. Defective or misaligned electrode at the pilot	Using a match, light pilot. If pilot lights, turn off pilot and push the ignitor button again. If pilot will not light, check gap at electrode and pilot - it should be 1/8" to have a strong spark.
	B. Defective ignitor (push button)	Push piezo ignitor button. Check for spark at electrode and pilot. If there is no spark at the pilot, and electrode wire is properly connected, replace ignitor.
2. Pilot will not stay lit after carefully following the lighting instructions	A. Defective pilot generator (thermocouple)	Check pilot flame. It must impinge on the thermocouple or thermopile. NOTE: This pilot burner assembly uses both a thermocouple and a thermopile. The thermocouple operates the pilot flame. Tighten the thermocouple. The thermopile operates the main valve (ON and OFF). Clean and/or adjust pilot for maximum flame impingement on thermocouple and thermopile.
	B. Defective automatic valve operator	Turn valve knob to 'Pilot'. Maintain flow to pilot; millivolt meter should read greater than 10mV. If the reading is okay and the pilot does not stay on, replace the gas valve. NOTE: An interrupter block (not supplied) must be used to conduct this test.
3. Pilot lights, no gas to burner, valve knob ON, remote switch (rocker switch) ON	A. Remote switch or wires defective	Check rocker switch and wires for proper connection. Use jumper wires across terminals at rocker switch. If burner lights, replace rocker switch. If okay, use jumper wires across rocker switch wires at the valve; if burner lights, wires are faulty or connections are bad.
	B. Thermopile may not generate sufficient voltage	1. Be sure wire connections from thermopile at gas valve terminals are tight and thermopile is fully inserted into pilot bracket.
		2. One of the rocker switch wires may be grounded. Remove rocker switch wires from valve terminals. If burner now stays lit, trace rocker switch wiring from ground. It may be grounded to the appliance or the gas supply line.
		3. Check the thermopile with a millivolt meter. Take reading at thermopile ("TP" and "TP/TH") terminals of gas valve. Should read 325 millivolts minimum while holding valve knob depressed in PILOT position and with rocker switch OFF. Replace faulty thermopile if reading is below specified minimum.
C. Plugged burner orifice	Check burner orifices for debris, and remove.	
D. Defective automatic valve operator	Turn knob to ON, place rocker switch to ON, millivolt meter should read greater than 10 mV. If the reading is okay and the burner does not light, replace the valve.	
4. Frequent pilot outage	A. Pilot flame may be too low or high, (blowing or lifting), causing the pilot to drop out	Clean and/or adjust pilot flame for maximum flame impingement on thermocouple and thermopile.
	B. Possible blockage of the vent terminal	Check the vent terminal for blockage.

Instructions for RF Comfort Control Valve

The Comfort Control Valve allows remote control of temperature, fan and flame appearance.

NOTE: The antenna should hang in free air away from grounded metal.

Operation

1. If the manual switch is in remote position, switch it to LOCAL. (Fig. 53)
2. Turn the pilotstat knob counterclockwise from OFF to the PILOT position, push the knob down, and hold in position. The pilot valve opens and allows gas to flow to the pilot burner.
3. Push plunger on the piezo until the pilot burner is lit. When the pilot burner is lit, the LED on the control will come on after approximately 40 seconds and will provide 1 short blink continuously in the normal mode. When the light turns off which will be approximately 10 seconds after it has been continuously red, the receiver/valve is fully powered.

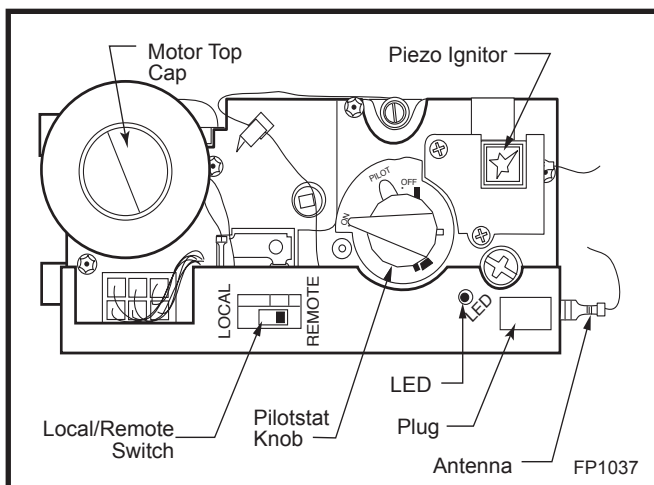

Fig. 53 Comfort control valve.

4. Release the knob. The shaft will move upward. The pilot burner should now stay burning. If the pilot burner goes out, repeat step 2.
5. Turn the knob counterclockwise to the ON position. If the manual switch is in the LOCAL position, the main burner will turn on immediately.
6. ON the initial use of a transmitter, a recognition operation is required between the receiver/valve and transmitter. Change the switch from LOCAL to REMOTE. Press the fan or flame button on the transmitter within 30 seconds. The LED will blink indicating the transmitter will now work with the receiver/valve. If the switch continues in the REMOTE position, the transmitter will now control the main valve, flame modulation level and fan control.

7. If the manual switch is in the LOCAL position, the valve will be at the highest fixed pressure setting and the fan will be at the highest fixed speed. The transmitter will control the fan only.

Shut Off Procedure

If the manual switch is in the REMOTE position, the transmitter can shut off the main burner and fan. However, the control is still on and a command from the transmitter can turn on the main burner or fan.

To shut off the system, turn the pilotstat knob clockwise to the OFF position. This action closes the main gas and safety valves. The transmitter cannot turn on the main burner or fan.

Transmitter Operation Off Mode

In the OFF mode, the fireplace flame and fan are off, the display will show OFF and displays the room temperature. If the receiver is in REMOTE mode, the fireplace will shut off.

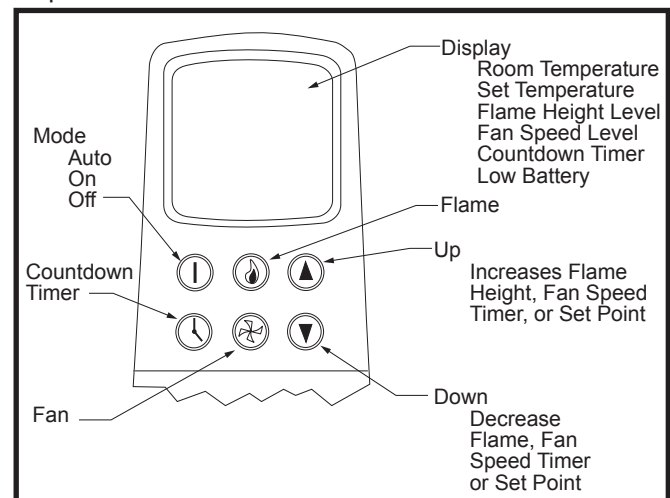

Fig. 54 Transmitter diagram.

On (Manual) Mode

In the ON mode, the room temperature, flame and fan levels will be shown. MANUAL will appear next to both the flame and fan icons.

When the control is in the ON mode, the flame and fan levels, and delay timer are changed with the up and down buttons. To change the flame level, press the flame button followed by an arrow key. To change the fan level, press the fan key followed by an arrow key. Pushing the arrow key once will change the level by one unit.

Delay Timer Mode

The shut off delay timer has a maximum of 2 hours and a minimum of zero minutes. To change the timer level, press the time key followed by an arrow key. Pushing the key once will change the timer by 10 minutes.

Auto Mode

In the AUTO mode, the room temperature, set temperature, flame and fan levels will be shown. AUTO will appear next to both the flame and fan icons.

When the control is in the AUTO mode, the main burner will turn on/off or modulate based on the heat needed to maintain the set temperature. The flame level will change automatically to optimize the heat output needed to maintain the set temperature. To change the set temperature, press the up or down key. Pushing a key once will change the temperature by one degree.

In the AUTO mode, the fan speed will increase with increasing flame height or decrease with decreasing flame height. "AUTO" is displayed next to the flame and fan icons.

Fan Override During Auto Mode

If a lower or higher fan speed is desired when operating in the AUTO mode, the fan speed can be overridden by pushing the fan button followed by the up or down key. Pushing a key once will change the fan level by one unit. In this mode "AUTO" is displayed next to the flame icon and "MANUAL" is displayed next to the fan icon.

Change Between F/C Temperature Units

Push the up and down arrow keys simultaneously for at least 3 seconds to toggle between Fahrenheit and Celsius units.

Disable Thermostat Function

To disable the thermostat function in the AUTO mode, push the time and down keys simultaneously for at least 3 seconds.

To Change Batteries

1. Remove cover on the backside of the transmitter. Install 3 AAA batteries as shown and reattach cover.
2. Once steps 1-3 in OPERATION are completed, receiver/valve and transmitter are now ready. Press any button on transmitter for recognition process to occur between the receiver/valve and transmitter.
3. Use functions as described in TRANSMITTER section.

Troubleshooting

1. Locate LED light on valve.
2. LED will blink after every valid command received by the transmitter; this is not an error.
3. Failure codes may occur anytime after pilot burner is lit.
4. Sequence is failure code followed by light not blinking for 30 seconds.
5. In the event of multiple failure codes, next failure code follows previous failure code by approximately 3 seconds.

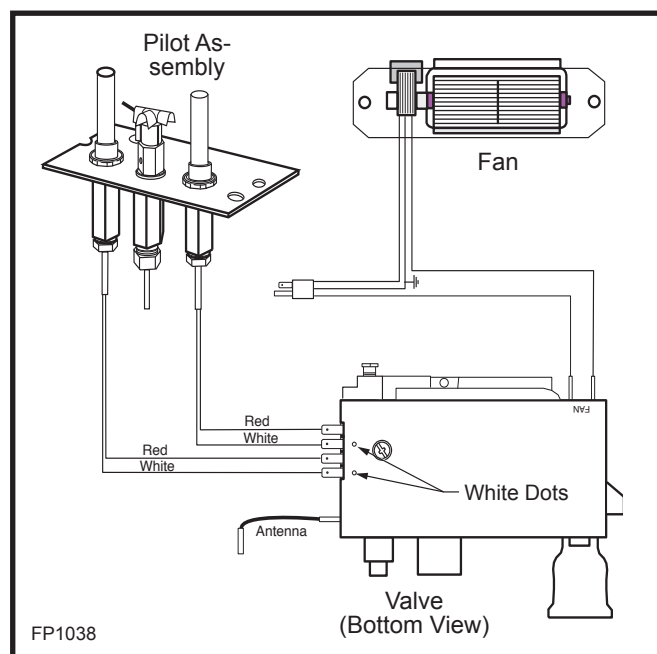

Fig. 55 Comfort Valve wiring diagram.

If an Error Code 3 is observed while performing the testing, complete the following:

1. Make sure the spade connectors are pushed all the way on. If the Error Code 3 is still showing, then go to the next step.
2. Switch the front two thermopile leads with the back two. Be sure the white lead is connected to the spade with the white dot next to it. If the Error Code 3 is still showing, replace the thermopiles.

If an Error Code 8 is observed while performing the testing, complete the following:

1. Confirm the valve is not in REMOTE mode.
 - If the valve is producing Error Code 8 and in REMOTE mode, the valve is defective and should be replaced.
 - If the valve is in LOCAL mode and producing Error Code 8, then go to the next step.
2. Slide the Remote/Local switch to REMOTE and teach the valve a transmitter (see item 6, page 1). The Error Code will clear itself after approximately 1.5 minutes and return to normal operation.

LED Count	Service Action
8	Replace valve
7	Confirm stepper motor connection exists
5	Confirm fan connection exists and works
4	Confirm gas type; jumper in place
3	Replace thermopiles
2	Turn fan ON

NOTE: Some keys are not active.

Comfort Valve System Control Sequence Of Operation With Transmitter

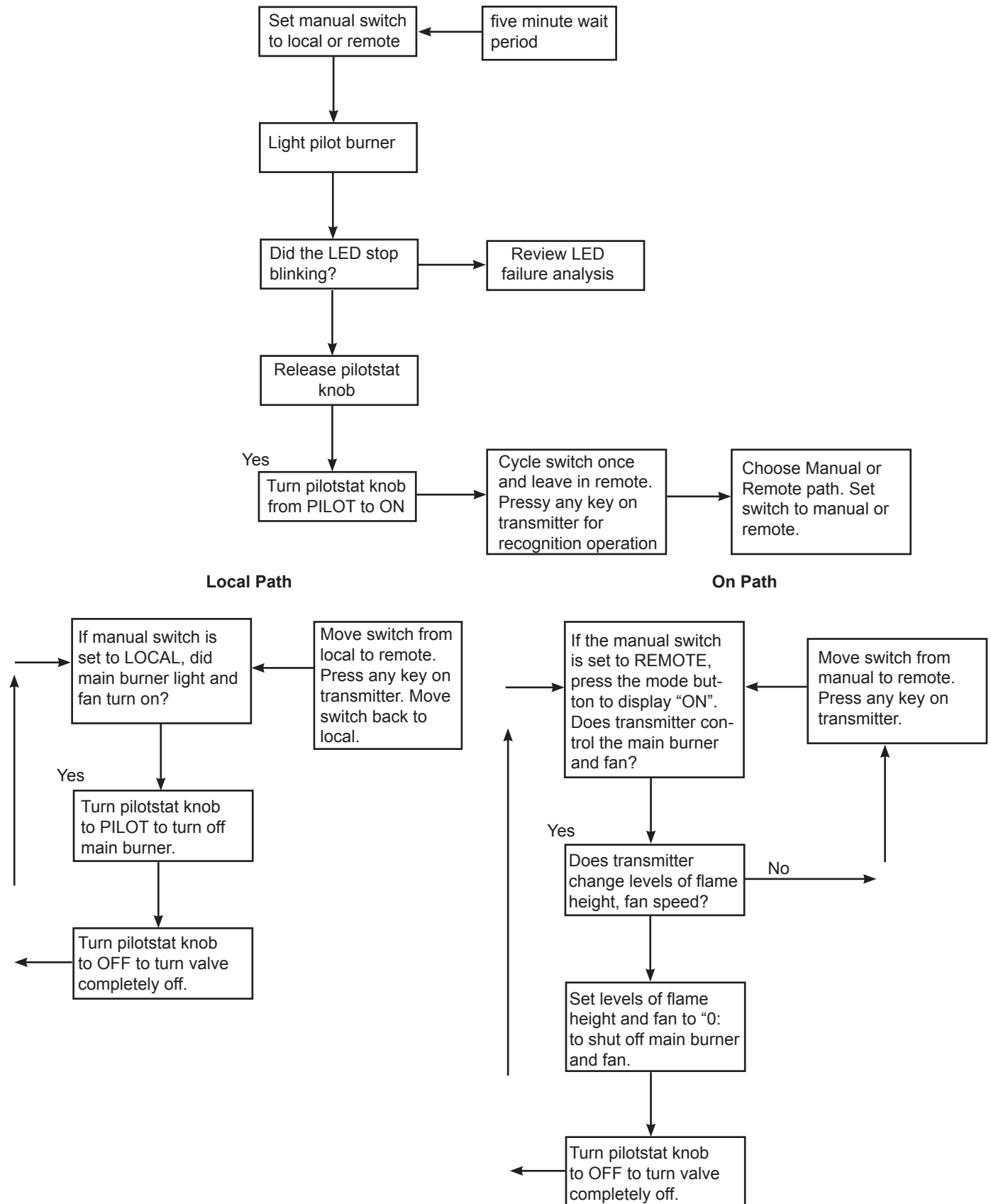

Auto Path

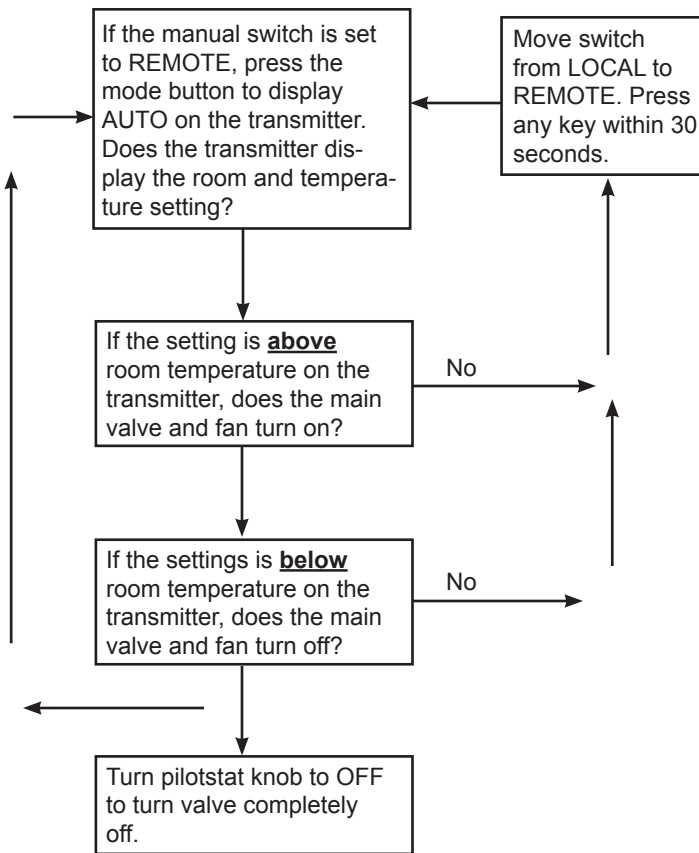

Fuel Conversion Instructions

WARNING! This conversion kit shall be installed by a qualified service agency in accordance with the manufacturer's instructions and all applicable codes and requirements of the authority having jurisdiction. If the information in these instructions is not followed exactly, a fire, explosion or production of carbon monoxide may result causing property damage, personal injury or loss of life. The qualified service agency is responsible for the proper installation of this kit. The installation is not proper and complete until the operation of the converted appliance is checked as specified in the manufacturer's instructions supplied with the kit.

CAUTION: The gas supply shall be shut off prior to disconnecting the electrical power, before proceeding with the conversion.

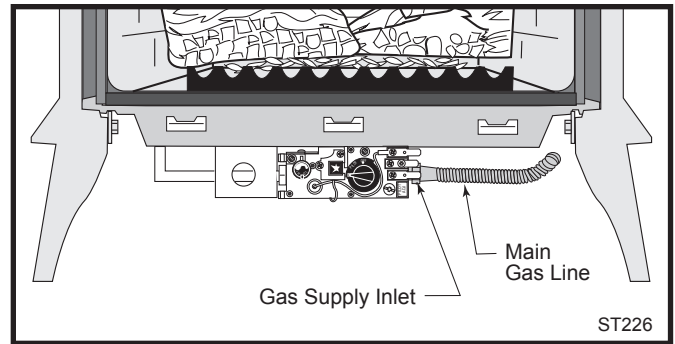

Fig. 56 Attach the gas line to the right side of the valve.

Conversion Precautions

Before proceeding, turn control knob on valve to OFF and turn gas supply OFF. Turn OFF any electricity that may be going to the appliance.

Conversion Procedure

1. Remove stove front. Lift stove front up and then swing bottom out and away to disengage from the stove body. (Page 37, Fig. 67)
2. Swing open the swiveling latches at the top left and right corners of the glass frame. (Page 38, Fig. 68)
3. Pull the top edge of the glass and frame assembly away from the firebox face. Place the assembly out of the way on a flat, padded surface such as a counter protected by a towel.
4. Remove the logset from the firebox.
5. Remove the rear log bracket by unfastening the screw. (Fig. 57)
6. Remove the right and left log bracket assembly by unfastening the two screws which hold the burner in place. (Fig. 57)

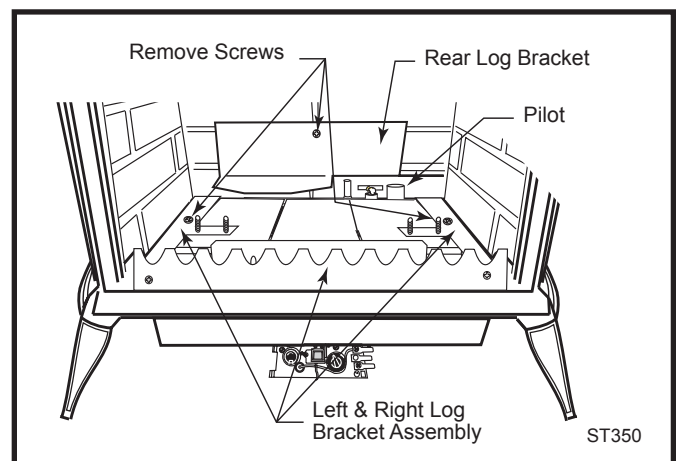

Fig. 57 Remove rear log bracket and left and right log bracket assembly.

7. Hold the burner at the right hand side and lift to clear the right burner leg. Then pull to the right to clear the injectors on the left hand side.
8. Remove injector orifices from left burner leg using 1/2" wrench. (Fig. 66)
9. Install conversion orifices. (See Table 2)

Valve Conversion

Models 3920, 3930, 4065, 4070 (R Models) Only

Honeywell Valve

1. Remove cap from Hi-Lo knob. This can be accomplished by lifting the plastic cap off the screw. (Fig. 58)
2. Remove the screw from center of Hi-Lo knob with small screwdriver turning counterclockwise. (Fig. 58)
3. Insert blue painted screw when converting to natural gas and red painted screw when converting to LP.
4. Tighten screw (do not over tighten), replace cap.

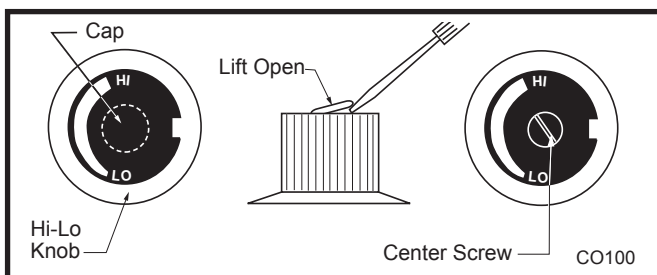

Fig. 58 Remove center screw from Hi-Lo knob.

SIT 820 Valve

1. Using TORX T20 bit, remove and discard the three (3) pressure regulator mounting screws (A), pressure regulator tower (B) and the spring and diaphragm assembly (C). (Fig. 59)
2. Insure the rubber gasket (D) is properly positioned and install the new HI/LO pressure regulator assem-

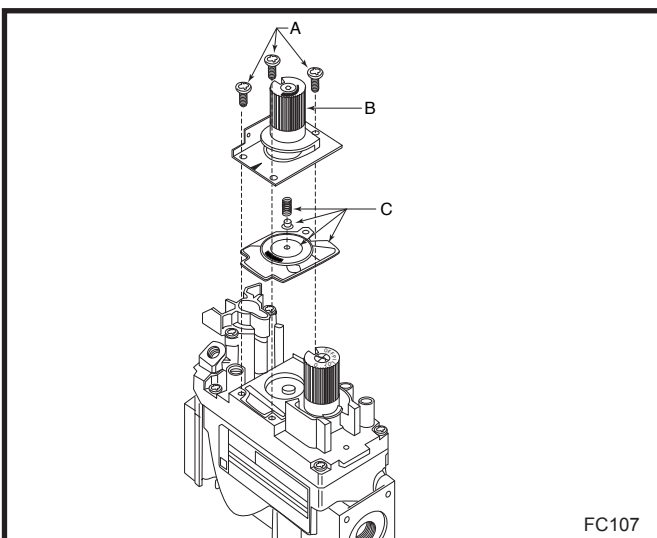

Fig. 59 Remove mounting screws, pressure regulator tower and spring and diaphragm assembly.

bly to the valve using the new screws (E) supplied with the kit. Tighten the screws securely. (Ref. torque = 25 in/lb) (Fig. 60)

3. Install the enclosed conversion label (F) to the valve body where it can easily be seen. (Fig. 60)

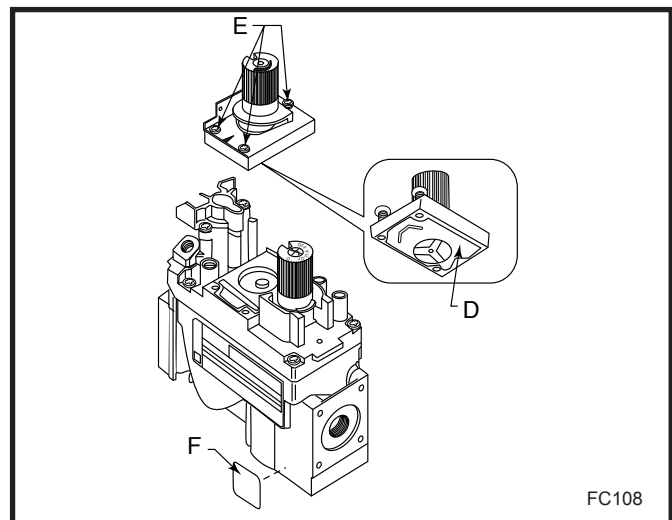

Fig. 60 Replace regulator.

Pilot Orifice Conversion

1. Locate pilot. (Fig. 57)
2. Replace pilot orifice:

Pilot Type 1

- Remove pilot hood by lifting up. (Fig. 61) **NOTE:** It is not necessary to remove the pilot tube for conversion.
- Remove pilot orifice with allen wrench. (Fig. 62)
- Install the conversion orifice.
- Reinstall pilot hood. Be sure to align hood with index tab.

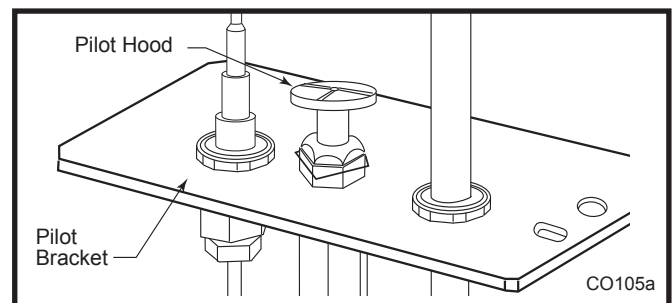

Fig. 61 Remove pilot hood.

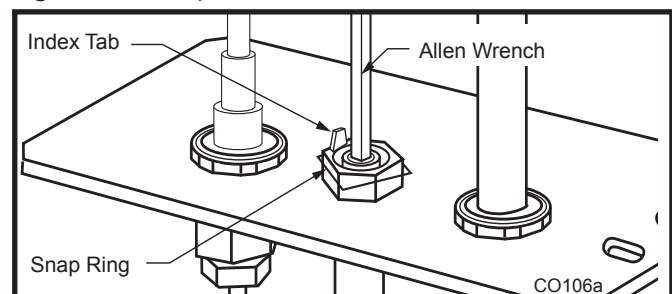

Fig. 62 Remove pilot orifice.

Pilot type 2

- Loosen pilot hood turning counterclockwise using a 7/16" wrench. (Fig. 63)
- Remove pilot orifice with needlenose pliers. (Fig. 64)
- Install the conversion orifice.
- Reinstall pilot hood and tighten until mark on pilot hood aligns with mark on pilot bracket.

NOTE: Be sure burner leg remains at a 90° angle to firebox base after conversion.

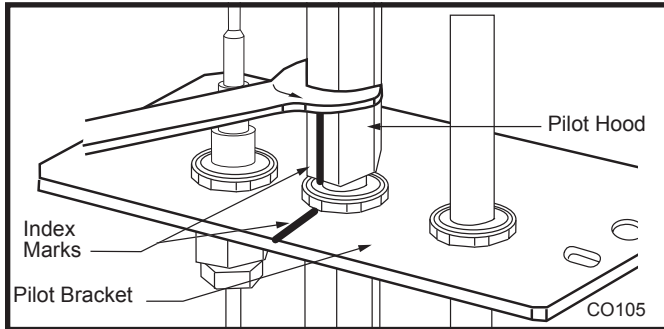

Fig. 63 Remove pilot hood. (Your pilot may have a different appearance.)

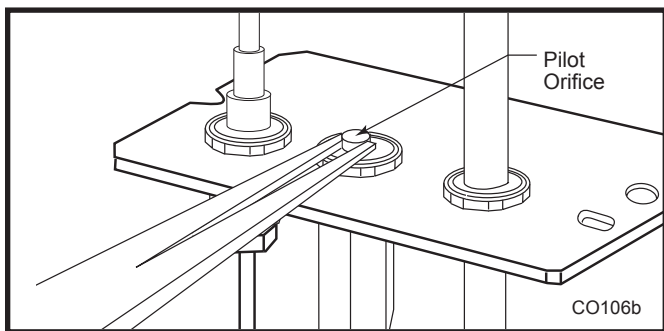

Fig. 64 Remove pilot orifice.

Models 3960, 3970, 4075, 4080 (RF Models) Only

1. Follow procedure for pilot type 2 to replace pilot orifice.
2. Remove and replace plug on lower right hand side of the valve; Red for LP and Blue for NG. (Page 30, Fig. 53)
3. Remove motor top cap. Depress and turn center plunger until arrow points to correct screw. Red for LP and Blue for NG. **NOTE:** Plunger will "snap" into NG position when arrow is close to blue screw. It will not "snap" at LP (Red) position. (Fig. 65)
4. Insure manifold pressure remains between 3.2" - 3.5" w.c. for NG and 9.5" - 10" w.c. for LP. To adjust the manifold pressure, for NG, using a torque #10 key turn the blue screw clockwise to increase the manifold pressure. Turn the screw counterclockwise to decrease the pressure. Use the red screw to adjust LP.
5. Replace motor top cap.

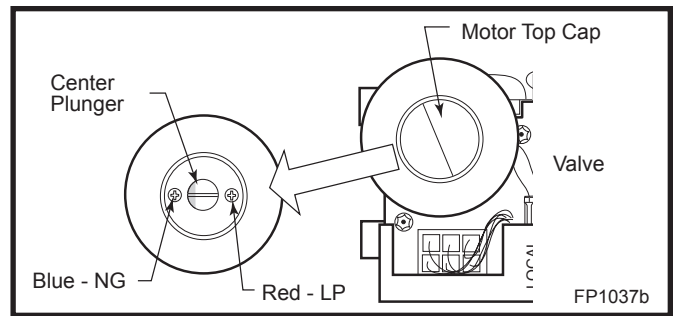

Fig. 65 Depress and turn center plunger.

All Models

1. Replace burner. Slide the burner in at an angle with left side lower than the right side. Slide the left side onto the injectors, making sure the burner leg remains at a 90° angle to the base. Lower the right hand side down in to place. Make sure the burner is as far left as possible and the injector shoulders are inside the burner.

NOTE: It is very critical to keep the left burner leg, which holds the injectors, at a 90° angle to the base. (Fig. 66) This keeps the orifices aligned with the tubes inside burner. Failure to do so could affect the flame appearance and performance of the unit.

2. Place conversion label on valve.
 3. Reinstall the right and left log bracket assembly.
 4. Reinstall the rear log bracket.
 5. Replace logs.
 6. Replace glass and stove front.
- Conversion is complete.

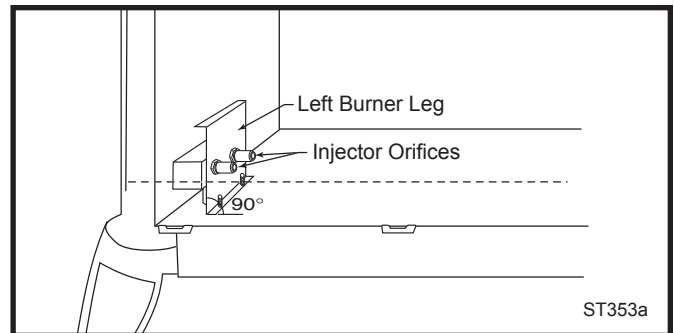

Fig. 66 Remove and replace injector orifices.

Table 2. Injector Orifice Size Matrix						
Conversion to Natural Gas					Input (BTU/h)	
Kit #	Front	Part #	Rear	Part #	Minimum	Maximum
000-5004	#56 / .0465"	30000336	#47 / .078"	20003054	14,000	21,000
000-5013	#56 / .0465"	30000336	#47 / .078"	20003054	14,000	21,000
Conversion to LP					Input (BTU/h)	
Kit #	Front	Part #	Rear	Part #	Minimum	Maximum
000-5005	#68 / .031"	30000694	#56 / .0465"	30000336	14,000	21,000
000-5014	#68 / .031"	30000694	#56 / .0465"	30000336	14,000	21,000

Maintenance

Your PDV20 and SDVR Gas Heaters will provide years of service with minimal upkeep. The following procedures will help ensure that your stove continues to function properly.

Annual System Inspection

Have the entire heater and venting system inspected annually by a qualified gas technician. Replace any worn or broken parts.

Logset and Burner Cleaning and Inspection

Cleanliness is critical to the proper function of the heater. The logset and burner must all be kept free of dust and unobstructed by debris. Inspect these areas before each use and clean as necessary.

1. Turn the burner OFF and let the heater cool completely before cleaning.
2. Lift the Stove Front up and then swing the bottom out to disengage it from the heater shell. (Fig. 67)
3. Carefully remove the glass and frame assembly and place it out of the way on a flat, padded surface such as a counter protected by a towel.
4. Carefully inspect the Logs for damage. Contact your local dealer if any damage is evident. **DO NOT OPERATE THE HEATER WITH DAMAGED LOGS.**
5. Use a soft bristled brush to sweep dust or debris from the Logs, Pilot and Burner. Use care as the logs are fragile and susceptible to damage.
6. Replace the glass panel and frame assembly.
7. Replace the Stove Front.

Care of Cast Iron

An occasional dusting with a dry rag will help keep the *painted surfaces* looking new. Use high-temperature stove paints, available through your local dealer, to touch-up areas as needed. Clean areas to be painted with a wire brush and be sure to cover the logs, burner and valve assembly, glass and frame assembly. Apply the paint sparingly; two light coats of paint will give better results than a single heavy coat.

Clean *porcelain enamel surfaces* with a soft, damp cloth. Do not use abrasive cleaning agents. If necessary, use only a cleaning agent formulated especially for use on porcelain enamel surfaces.

CAUTION

**TURN THE PILOT OFF BEFORE PAINTING.
ALLOW THE HEATER TO COOL COMPLETELY
BEFORE PAINTING.**

Cleaning the Glass

WARNING: Let the glass cool completely before attempting to clean.

It will be necessary to clean the glass periodically. During start-up, condensation, which is normal, forms on the inside of the glass and causes lint, dust and other airborne particles to cling to the glass surface. Also initial paint curing may deposit a slight film on the glass. It is therefore recommended that the glass be cleaned two or three times with a non-ammonia household cleaner and warm water (we recommend gas fireplace glass cleaner). After that the glass should be cleaned two or three times during each heating season depending on the circumstances present.



Clean glass after first two weeks of operation.

Glass Replacement

Replace glass only with CFM Corporation approved parts. Refer to Page 40 for Replacement Parts. Refer to Figure 68 and previous instructions for removal of the damaged glass frame.

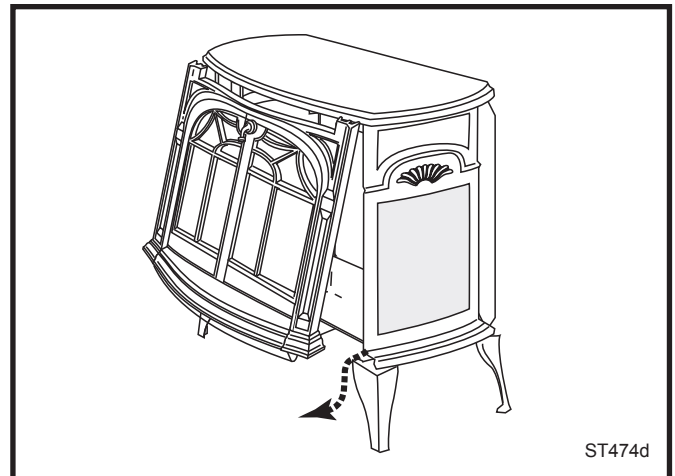

Fig. 67 Remove the Stove Front.

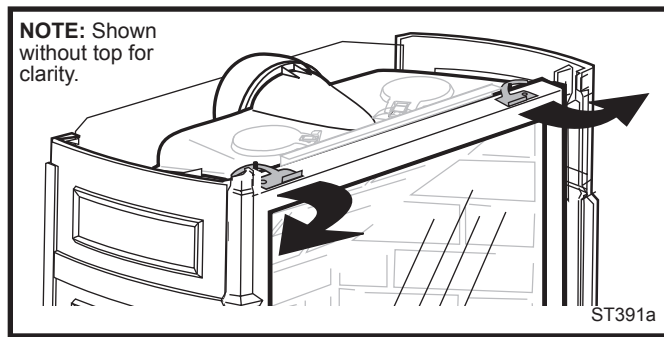

Fig. 68 Release the latches to release the glass frame.

Gasket Replacement

The PDV20 and SDVR Gas Heaters use a 'tadpole' type gasket to seal between the glass panel and the frame. In time, this gasket can become brittle and compressed and should be replaced. New gasket is available from your dealer.

Shut off the gas supply and allow the stove to cool. Wear safety goggles and a dust mask.

1. Remove the Front, Glass Frame and Glass Panel. (Figs. 67, 68) Remove the old gasket. Use a razor blade to separate the glass and gasket from the frame, and to clean the glass of any remaining cement or bits of gasket. Use a cold chisel if necessary.
2. Determine the correct length of gasket by laying it out around the edge of the glass. Allow an extra 1 - 2" (25-50mm). Mark the spot to be cut. Use a utility knife.
3. Starting on a long edge, remove about 6" of the protective paper strip and apply the flat adhesive face of the gasket around the outside-facing edge of the panel. Continue around the panel, applying about 6" at a time and being careful to not stretch the material. Do not overlap the gasket ends. (Fig. 69)
4. Apply a thin bead of high temperature silicone rubber sealant along the inside corner of the glass frame, all around the perimeter. Place the flat gasketed side of the glass panel back into the steel frame. Pinch the rounded inside-facing gasket material to bulk it up.
5. Replace the glass frame and front panel as previously described.

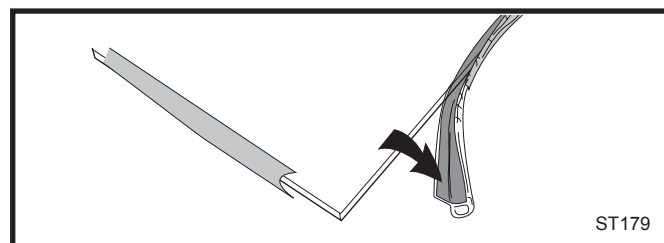

Fig. 69 Wrap the gasket material around the outside edge of the glass.

Inspect the Vent System Annually

Have the vent system inspected annually by a qualified technician. Shut off the main gas supply before inspecting the system. Both the inner exhaust pipe and the outer combustion supply pipe must be checked to confirm that they are unblocked and in good condition.

Check the Gas Flame Regularly

To ensure that the stove is operating properly, check the flames periodically to confirm that they match Figures 70 & 71. The flames will be blue during the first 15-20 minutes of operation, and will gradually turn to yellow after that.

Do not use your stove if the flame pattern differs from that shown here. Contact your Vermont Castings dealer or a qualified technician for help.

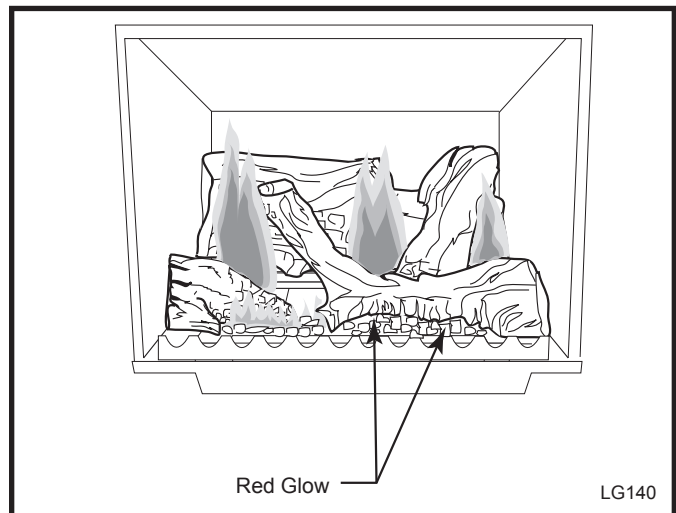

Fig. 70 Correct flame pattern.

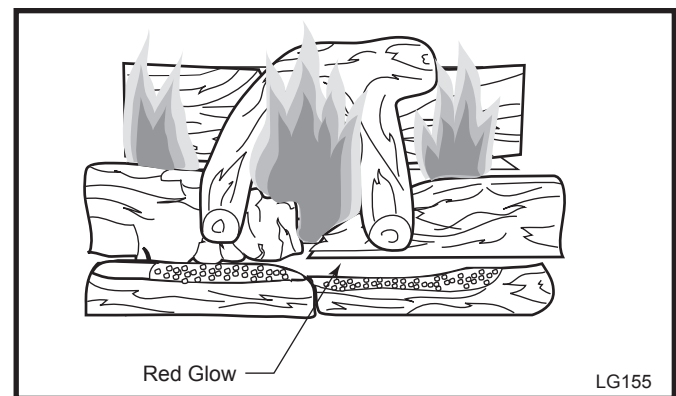

Fig. 71 Correct flame pattern, Models 2950, 2951.

Stove Disassembly

If there is ever a need to remove the firebox assembly from the stove shell, support the firebox with solid stands about 6" (152mm) tall under the left and right outer edges of the firebox base. Do not set the firebox assembly directly on the floor; this can damage the control valve and/or the gas lines from the valve to the firebox.

Before removing the firebox from the shell, disconnect the on/off switch wires from the valve. If the assembly includes the optional fan, disconnect the fan rheostat. If the installation includes a wall thermostat, disconnect the thermostat leads from valve.

Disconnection and reconnection to the gas line should only be done by a qualified gas service technician.

Upon reinstallation, the vent system must be sealed to the firebox as shown in the installation section, page 14. Also be sure the logs are placed in the firebox correctly, as shown in Page 25, Figures 43-44.

Wiring Diagrams

On/Off Switch Wiring

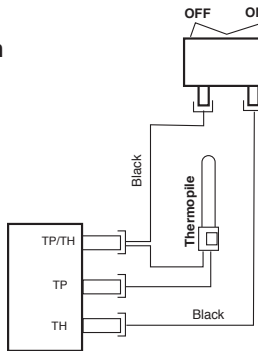

ST124b

Optional Thermostat Wiring

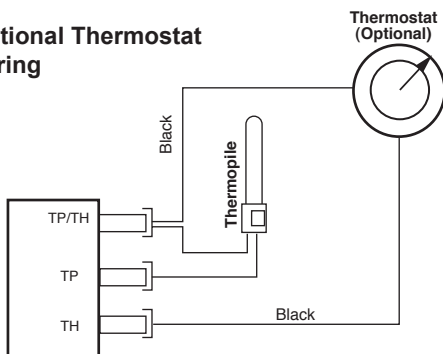

ST124c

Fig. 72 PDV20/SDVR on/off switch and optional thermostat circuit.

NOTE: IF ANY OF THE ORIGINAL WIRE, AS SUPPLIED WITH THE APPLIANCE, MUST BE REPLACED, IT MUST BE REPLACED WITH TYPE SF-2, 200°C WIRE OR ITS EQUIVALENT.

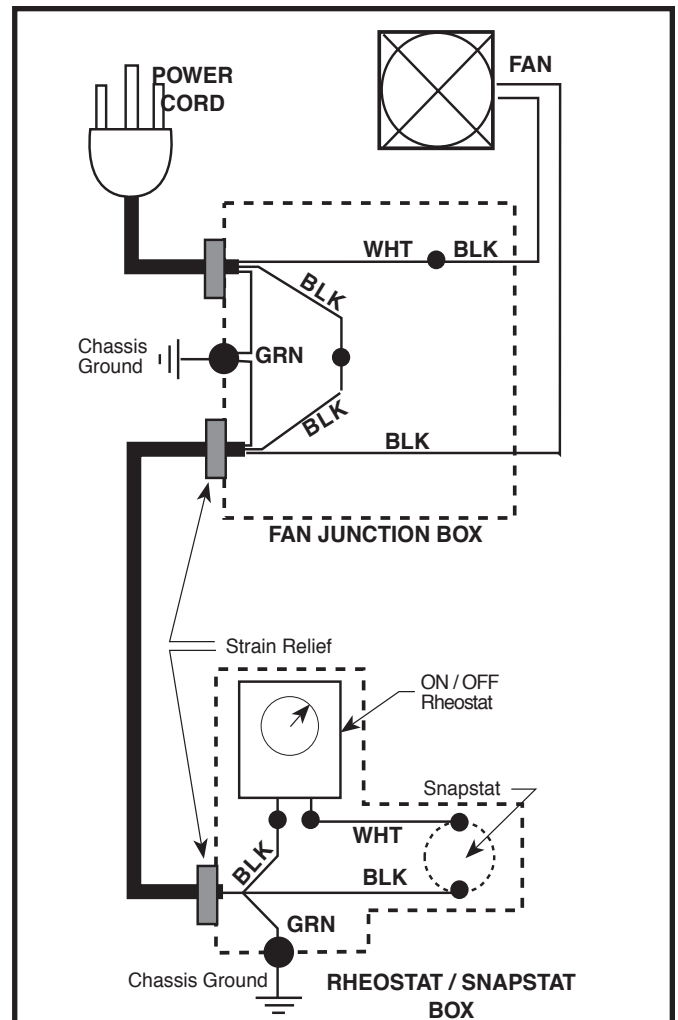

ST153

Schematic Diagram

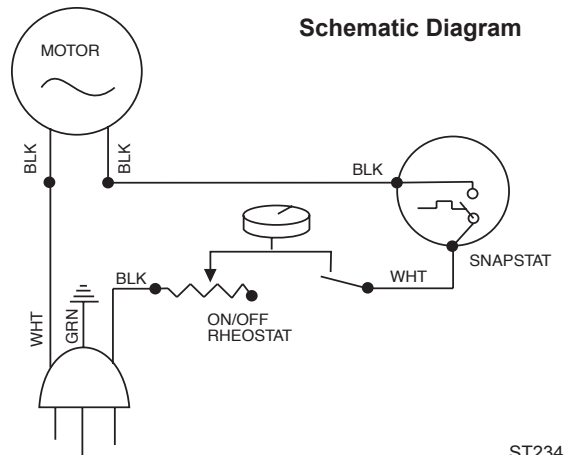

ST234

Fig. 73 PDV20/SDVR fan circuit.

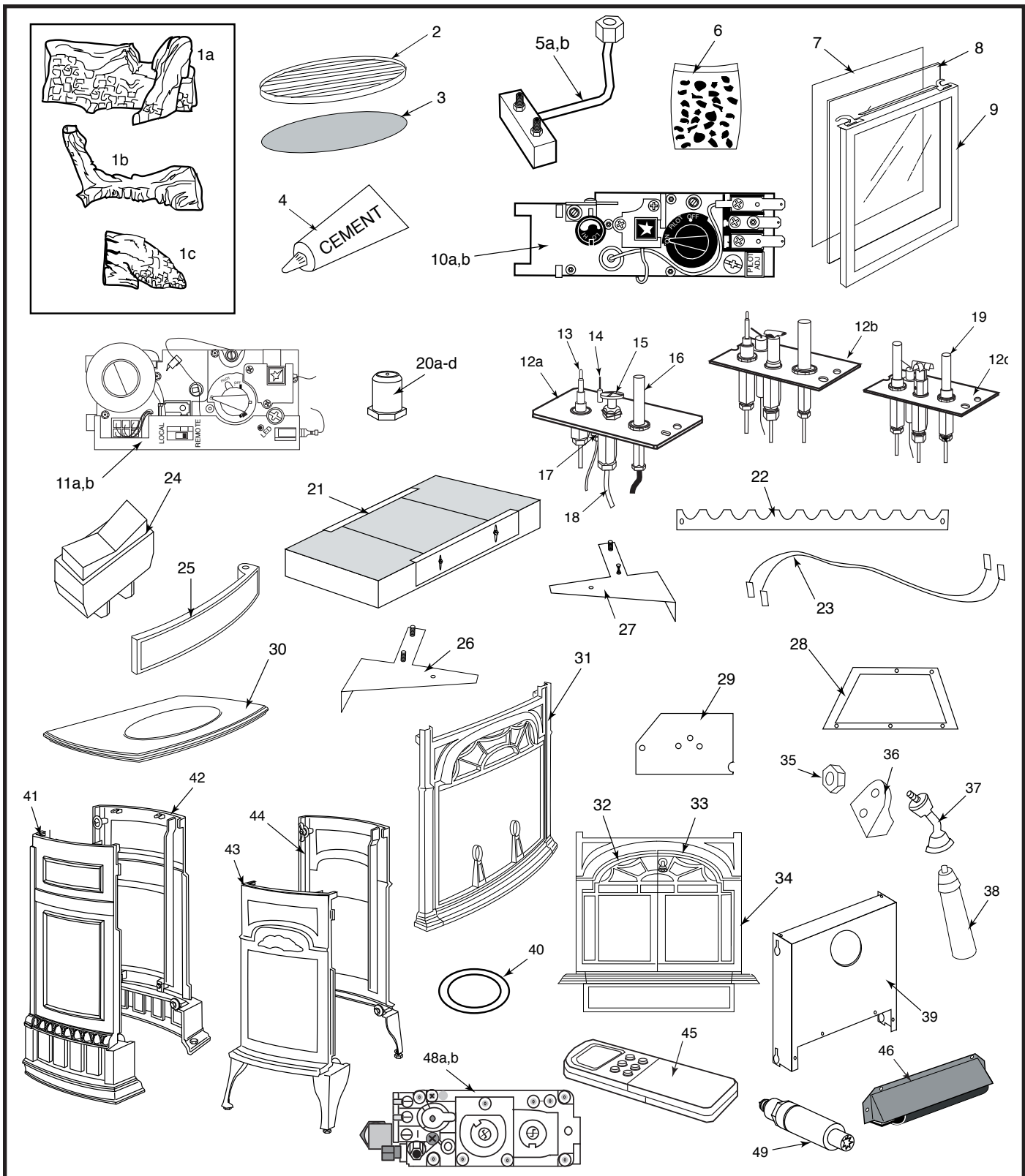

CFM Corporation reserves the right to make changes in design, materials, specifications, prices and discontinue colors and products at any time, without notice.

Pinnacle (PDV20) / Stardance (SDVR) Direct Vent/Rear Vent Gas Heater: Models SDVR: 3920-3936, 3960-3976; PDV20: 2995, 2997, 4065-4067, 4069-4072, 4075-4077, 4080-4083

Pinnacle (PDV20) / Stardance (SDVR) Direct Vent/Rear Vent Gas Heater, (continued)

Ref.	Description	PDV20	SDVR
1.	Gas Log Assembly	20003467	20003467
1a.	Log, Rear	20003463	20003463
1b.	Log, Right	20003464	20003464
1c.	Left Log	20003465	20003465
2.	Grille, UV30	30000393	30000393
3.	Mesh, Grille - UV30	30000508	30000508
4.	Cement, Gasket 3oz. Tube	1206122	1206122
5.	Manifold Assembly	20003739	20003739
6.	Lava Rocks Burner	57897	57897
7.	Gasket, Glass - Med. Knit-RDV40	1203702	1203702
8.	Glass, DV25	1601691	1601691
9.	Glass Frame Assembly, SDV30	30000127	30000127
10a.	Gas Valve, NG - Honeywell VS8420E 2038 (Serial #'s up to 3870)*	10001782	
10b.	Gas Valve, LP - Honeywell VS8420E 2020 (Serial #'s up to 3870)**	10001759	
11a.	Valve Gas Honeywell Convertible RFN RV8310E	20003719	20003719
11b.	Valve Gas Honeywell Convertible RFP RV8310E	20003720	20003720
12a.	Pilot Assembly 3Way N/DV RN 0.199.706	10002264	10002264
	Pilot Assembly 3Way N/DV RP 0.199.703	10002265	10002265
12b.	Pilot, PSE - NA175	20001115	20001115
	Pilot, PSE - LP175	20001116	20001116
12c.	Pilot Assembly 3Way DV/RFN CS3003A2009	20002266	20002266
	Pilot Assembly 3Way DV/RFP CS3003A2017	20002268	20002268
13.	Thermocouple, 24"	53373	53373
		7531137	7531137
14.	Electrode Ignitor w/ Cable SIT24	10001297	10001297
15.	Pilot Top Convertible	10002266	10002266
16.	Thermopile, 18" RS	51827	51827
		7533113	7533113
17.	Nut Electrode, SIT #0.974.144	57886	57886
18.	Tubing Pilot w/ Fittings 1/8 x 24"	10001296	10001296
19.	Thermopile - PSE for RF Pilots	20002400	20002400
20a.	Orifice Hood - Front - LP	30000694	30000694
20b.	Orifice Hood - Front - NG	30000336	30000336
20c.	Orifice Hood - Rear - LP	30000336	30000336
20d.	Orifice Hood - Rear - NG	20003054	20003054
21.	Burner Housing Assembly	20004066	20004066
22.	Grate, Burner JDV	20002167	20002167
23.	Wire w/Straight Terms End 50"	10002582	10002582
24.	Trim ON/OFF Switch - JDV	53606	53606
25.	Control FS/HM	Refer to Enamel Parts Chart Page 42	
26.	Bracket, Right Log	20005259	20005259
27.	Bracket, Left Log	20002165	20002165
28.	Gasket Base Pan	20002282	20002282
29.	Gasket Inner Base Pan	20002566	20002566
30.	Top, Stardance UV/PDV	Refer to Enamel Parts Chart Page 42	
31.	Front, HM-VC	Refer to Enamel Parts Chart Page 42	
32.	Door, Left - Stardance	Refer to Enamel Parts Chart Page 42	
33.	Door, Right - Stardance	Refer to Enamel Parts Chart Page 42	
34.	Front, Stardance OP Door	Refer to Enamel Parts Chart Page 42	
35.	Nut, Hex Jam 3/8 - 16 TOPLK-Z	1203290	1203290
36.	Pawl Assy, Ashdoor - ENC	5004025	5004025

Pinnacle (PDV20) / Stardance (SDVR) Direct Vent/Rear Vent Gas Heater (continued)

Ref.	Description	PDV20	SDVR
37.	Front Handle Shaft - NI/VER	30002717	30002717
38.	Handle Package, Ceramic w/Screw	0004345	0004345
39.	Rear Shroud Assembly, PDV20	20003801	20003801
40.	Gasket, HE Door	1203687	1203687
41.	Left End, PDV20	Refer to Enamel Parts Chart Page 42	
42.	Right End, PDV20	Refer to Enamel Parts Chart Page 42	
43.	Left End, SDVR	Refer to Enamel Parts Chart Page 42	
44.	Right End, SDVR	Refer to Enamel Parts Chart Page 42	
45.	Transmitter Honeywell RF	20002047	20002047
46.	FK28 Fan Subassembly for PDVRF	30000887	30000887
47.	1/4" Fiberglass Gasket	1203560	1203560
48a.	Valve Nova SIT820.662 RN (Serial #'s starting with 3871)		20010563
48b.	Valve Nova SIT820.653 RP (Serial #'s starting with 3871)		20010645
49.	Ignitor Piezo w/Nut SIT		52464
50.	Bracket Piezo Ignitor (not shown)		20010876

*When converting to SIT valve, must order RP275

**When converting to SIT valve, must order RP269

Fuel Conversion Kits

Conversion Kit, NG to LP	Kit #000-5005
PDV20RFN (Models 2997, 4065-4069, 4075- 4077, 4083) and SDV30RFN (Models 3960 thru 3969)	
Conversion Kit, NG to LP	Kit #000-5014
PDV20RN (Models 2995, 4065-4067, 4069) and SDV30RN (Models 3920 thru 3929)	
Conversion Kit, LP to NG	Kit #000-5004
PDV20RFP (Models 2998, 4080, 4081, 4082) and SDV30RFP Models 3970 thru 3976)	
Conversion Kit, LP to NG	Kit #000-5013
PDV20RP (Models 2996, 4070, 4071, 4072) and SDV30RP Models 3930 thru 3936)	

Shell Enamel Part Numbers - PDV20					
Color	Top	Left End	Right End	Front	Control Door
Classic	30001278	30001282	30001281	1301129	1301087
Sand	30001299	30001303	30001302	1321129	1321087
Ebony	30001306	30001310	30001309	1341129	1341087
Biscuit	30003307	30003325	30003324	30003326	30003327

Shell Enamel Part Numbers - SDVR						
Color	Top	Left End	Right End	Front (OP)	Left Door	Right Door
Classic	30001278	30001280	30001279	30001496	30001139	30001138
Biscuit	30003307	30003300	30003301	30003302	30003304	30003303
Bordeaux	30001285	30001287	30001286	30001261	30001263	30001262
Chestnut Brown	30003315	30003308	30003309	30003310	30003312	30003311
Ebony	30001306	30001308	30001307	30001270	30001272	30001271
Forest Green	30001292	30001294	30001293	30001264	30001266	30001265
Midnight Blue	30001319	30001321	30001320	30001314	30001316	30001315
Sand	30001299	30001301	30001300	30001267	30001269	30001268
Suede Brown	30002554	30002547	30002548	30002550	30002552	30002551
Vermont Classic Green	30003323	30003316	30003317	30003318	30003320	30003319

Optional Accessories

Fan Kits

FK28 Fan

The FK28 fan helps distribute heated air from within the firebox out into the room. The fan is controlled by a snapstat that turns power on and off as the firebox temperature rises above and falls below a preset temperature. A rheostat provides for variable fan speeds.

Specifications

115 Volt / 60Hz / .75 Amps

Maintenance

The fan itself does not require regular maintenance, however, periodic cleaning of the fan and the surrounding area is required.

Installation

Refer to Page 13 for installation instructions.

Remote Controls

The remote control allows you to turn the heater on or off from anywhere in the room. Refer to Page 40 for wiring diagrams. These remote controls are for use on RN/RP model stoves.

Model Functions Controlled

RC1	ON/OFF
RC2	ON/OFF and Temperature
IMTFK	Wall mounted thermostat control

Screen Kit

An optional screen, S30SK, for use with the operable doors is available for the Stardance only. The screen is used when the doors are left in the open position.

Warming Shelf

Warming shelves add versatility to your stove; they can be used to keep foods warm at mealtime.

Model Color

2702	Classic Black
2684	Biscuit
2685	Chestnut Brown (Stardance Only)
2688	Vt. Classic Green (Stardance Only)
2704	Bordeaux (Stardance only)
2706	Forest Green (Stardance only)
2711	Midnight Blue (Stardance only)
2764	Sand
2765	Ebony

The shelf installation is completed in three stages. First attach the shelf loosely to the stove, leaving the screws loose enough to allow final adjustments. Then, position the shelf and adjust the brackets so the shelf fits correctly. Finally, tighten the screws.

Refer to the instructions included with each warming shelf for complete installation procedures.

LIMITED LIFETIME WARRANTY

PRODUCT COVERED BY THIS WARRANTY

All Vermont Castings gas stoves, gas inserts, and gas fireplaces, and all Majestic or brand gas fireplaces equipped with an Insta-Flame Ceramic Burner, or standard steel tube burner.

BASIC WARRANTY

CFM Corporation (hereinafter referred to collectively as the Company) warrants that your new Vermont Castings or Majestic Gas Fireplace/Stove is free from manufacturing and material defects for a period of one year from the date of purchase, subject to the following conditions and limitations.

EXTENDED LIFETIME WARRANTY

The heat exchanger, where applicable, and combustion chamber of every Vermont Castings or Majestic gas product is warranted for life against through wall perforation. All appliances equipped with an Insta-Flame Ceramic Burner have limited lifetime coverage on the ceramic burner plaque. Warrantees are made to the original owner subject to proof of purchase and the conditions and limitations listed on this Warranty Document

COMPONENT WARRANTY

CAST IRON: All external and internal cast iron parts are warranted for a period of three years.

Note: On porcelain enamel finished external parts and accessories The Company offers no Warranty on chipping of enamel surfaces. Inspect all product prior to accepting it for any damage to the enamel.

The salt air environment of coastal areas or a high humidity environment can be corrosive to the porcelain enamel finish. These conditions can cause rusting of the cast iron beneath the porcelain enamel finish, which will cause the finish to flake off.

Dye lot variations with replacement parts and/or accessories can occur and are not covered by warranty.

GLASS DOORS: Glass doors are covered for a period of one year.

Glass doors are not warranted for breakage due to misuse or accident. Glass doors are not covered for discoloration or burned in stains due to environmental issues, or improper cleaning and maintenance.

BRASS PLATED PARTS AND ACCESSORIES: Brass parts should be cleaned with Lemon oil only. Brass cleaners cannot be used. Mortar mix and masonry cleaners may corrode the brass finish. The Company will not be responsible for, nor will it warrant any brass parts which are damaged by external chemicals or down draft conditions.

GAS VALVES: Gas valves are covered for a period of one year

ELECTRONIC AND MECHANICAL COMPONENTS: Electronic and mechanical components of the burner assembly are covered for one year. All steel tube burners are warranted for one year.

ACCESSORIES: Unless otherwise noted all components and CFM Corporation company supplied accessories are covered for a period of one year.

CONDITIONS AND LIMITATIONS

- This Vermont Castings or Majestic product must be installed or serviced by a qualified installer, preferably NFI or WETT (Canada) certified, as prescribed by the local jurisdiction. It must be installed and operated at all times in accordance with the Installation and Operating instructions furnished with the product. Any alteration, willful abuse, accident, or misuse of the product shall nullify this warranty.
- This warranty is non-transferable, and is made to the original owner, provided that the purchase was made through an authorized supplier of the Company.
- The customer must pay for any Authorized Dealer in-home travel fees or service charges for in-home repair work. It is the dealers option whether the repair work will be done in the customer's home or in the dealer's shop.
- If upon inspection, the damage is found to be the fault of the manufacturer, repairs will be authorized at no charge to the customer parts and/or labor.

- Any part and/or component replaced under the provisions of this warranty is covered for six months or the remainder of the original warranty, whichever is longest.
- This warranty is limited to the repair of or replacement of part(s) found to be defective in material or workmanship, provided that such part(s) have been subjected to normal conditions of use and service, after said defect is confirmed by the Company's inspection.
- The company may, at its discretion, fully discharge all obligations with respect to this warranty by refunding the wholesale price of the defective part(s)
- Any installation, labor, construction, transportation, or other related costs/expenses arising from defective part(s), repair, replacement, or otherwise of same, will not be covered by this warranty, nor shall the Company assume responsibility for same. Further, the Company will not be responsible for any incidental, indirect, or consequential damages except as provided by law.
- SOME STATES DO NOT ALLOW FOR THE EXCLUSION OR LIMITATIONS OF INCIDENTAL AND CONSEQUENTIAL DAMAGES OR LIMITATIONS ON HOW LONG AN IMPLIED WARRANTY LASTS, SO THE ABOVE LIMITATIONS MAY NOT APPLY TO YOUR CIRCUMSTANCES. THIS WARRANTY GIVES YOU SPECIFIC RIGHTS AND YOU MAY HAVE OTHER RIGHTS WHICH VARY FROM STATE TO STATE.
- All other warranties-expressed or implied- with respect to the product, its components and accessories, or any obligations/liabilities on the part of the Company are hereby expressly excluded.
- The Company neither assumes, nor authorizes any third party to assume on its behalf, any other liabilities with respect to the sale of this Vermont Castings or Majestic product
- The warranties as outlined within this document do not apply to chimney components or other non CFM Corporation accessories used in conjunction with the installation of this product..
- Damage to the unit while in transit is not covered by this warranty but is subject to claim against the common carrier. Contact the dealer from whom you purchased your fireplace/stove (do not operate the appliance as this might negate the ability to process the claim with the carrier).
- The Company will not be responsible for:
 - a) Down drafts or spillage caused by environmental conditions such as near-by trees, buildings, roof tops, hills, or mountains.
 - b) Inadequate ventilation or negative air pressure caused by mechanical systems such as furnaces, fans, clothes dryers, etc.
- This warranty is void if:
 - a) The fireplace has been operated in atmospheres contaminated by chlorine, fluorine, or other damaging chemicals.
 - b) The fireplace has been subjected to prolonged periods of dampness or condensation
 - c) Any damages to the fireplace, combustion chamber, heat exchanger or other components due to water, or weather damage, which is the result of but not limited to, improper chimney/venting installation.
 - d) Any alteration, willful abuse, accident, or misuse of the product has occurred.

IF WARRANTY SERVICE IS NEEDED...

- 1) Contact your supplier. Make sure you have your warranty, your sales receipt, and the model/serial number of your CFM Corporation product.
- 2) DO NOT ATTEMPT TO DO ANY SERVICE WORK YOURSELF.

Canada

ENERGUIDE

Look for the **EnerGuide**
Gas Fireplace Energy
Efficiency Rating in this brochure

Based on CSA P.4.1-02

Efficiency Ratings

Model	EnerGuide Ratings Fireplace Efficiency (%)
PDV20RN	63.1
PDV20RP	63.1
PDV20RFN	63.1
PDF20RFP	63.1
SDVRRN	63.1
SDVRRP	63.1
SDVRRFN	63.1
SDVRRFP	63.1

NATIONAL
FIREPLACE
INSTITUTE



CERTIFIED
www.nficertified.org

We recommend that our gas hearth products be installed and serviced by professionals who are certified in the U.S. by the National Fireplace Institute® (NFI) as NFI Gas Specialists.

CFM Corporation

410 Admiral Blvd. • Mississauga, Ontario, Canada L5T 2N6
800-668-5323 • www.cfmcorp.com