

This appliance has been retired.
For current replacement part numbers, please refer to the
individual service parts list located on the brand
websites or contact your local dealer for part availability.

FOR REFERENCE ONLY

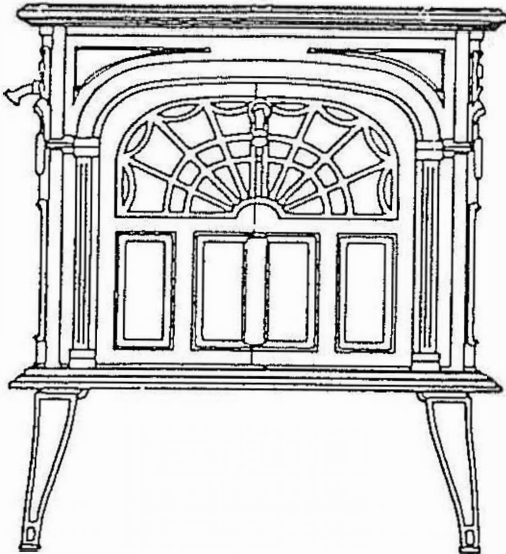

INTREPID I
WOODSTOVE
(1302) &
(Coal Stove
1315)



1. Intrepid Exploded View Stove Part Diagram and Parts List
2. Intrepid Drill and Tap Diagram and Tap Key
3. Intrepid Disassembling and Assembly of Interior Castings
4. Intrepid Complete Refurbishing

INTREPID I MODEL 1302

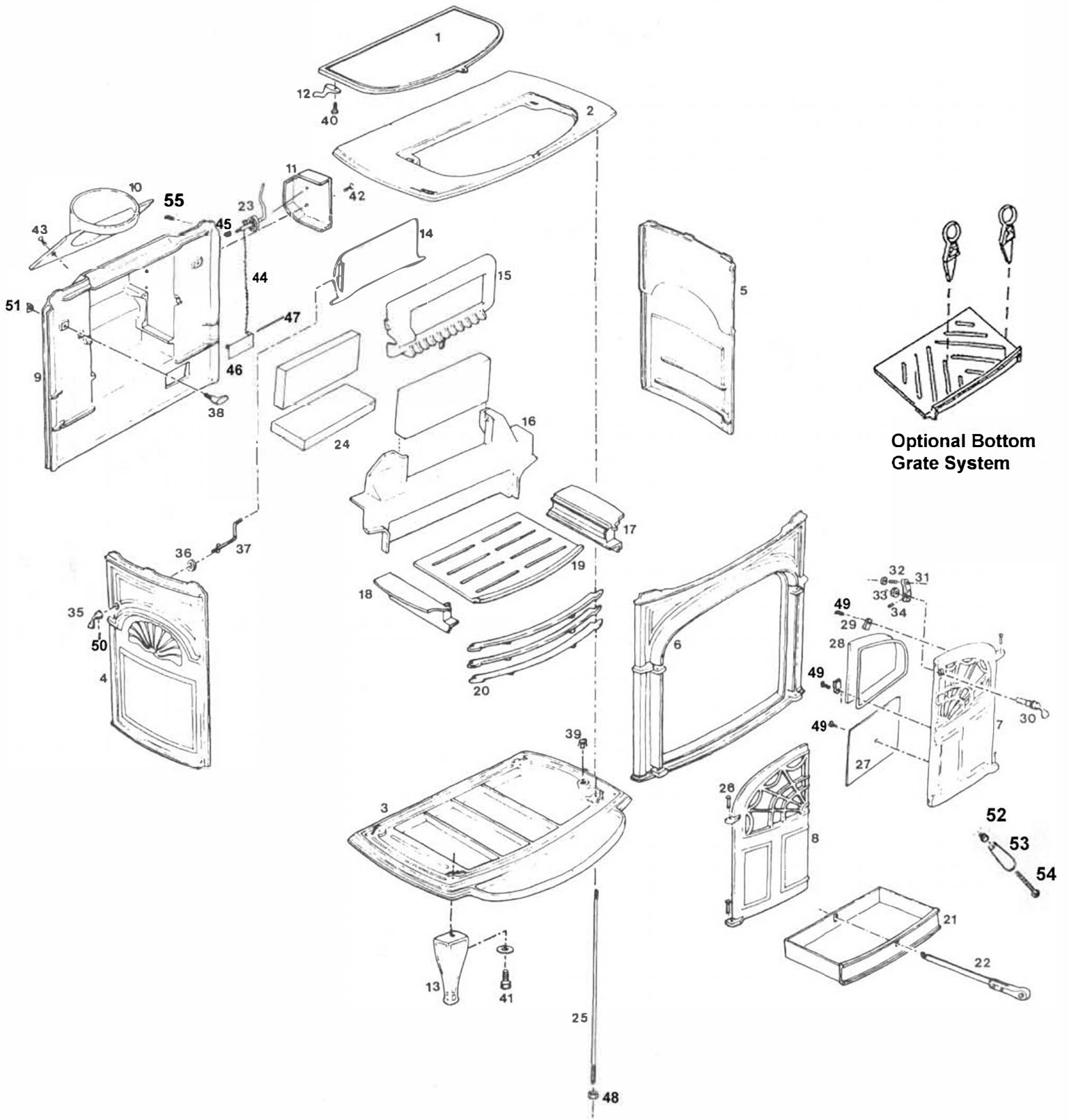

Optional Bottom Grate System

INTREPID I

MODEL #: 1302 INTREPID I

FEATURES: MANUFACTURED 7/29/82 TO 6/9/88, HAS NO CATALYST

** denotes dead product - not available*

ITEM #	PART #	DESCRIPTION
1	130-6356	Griddle (no quads)
2	130-8657	Top (replaces 130-6760)
3	130-6764	Bottom (replaces 130-6700)
4	130-6428*	Left End
5	130-6324*	Right End
6	500-4608	Front with Doors - Single Glass
7	130-6765	Right Door Single Glass
8	130-6766	Left Door Single Glass
9	130-6416	Back
10	130-6561	Flue Collar
11	130-6339	Thermostat Cover
12	130-0809	Griddle Quad (000-4444)
13	130-6333	Leg (one only)
	500-3457	Legs (set of four)
14	130-6367	Damper
15	130-6381	Upper Fireback
16	130-6451	Lower Fireback
17	130-6485	Right Air Tube
18	130-6479	Left Air Tube
19	130-6473*	Bottom Grate SUBSTITUTE:
	130-6712	Bottom Grate (does not use bottom grate bars)
	130-6717	Andiron (use two in place of bottom grate bars)
20	130-6437	Front Grate Bar (sub andirons if using 130-6712)
21	500-3522	Ash Pan Assembly
22	500-5708	Slicer/Poker
23	500-5467	Thermostat Assembly
	120-1985	Jump Ring
	120-1972	Ball Chain Fitting
24	160-1103	Firebrick Split (9" x 4½" Firebrick Slim)
25	500-7499	Tie Rod Set c/w Nuts
26	160-0535	Door Hinge Pin

** denotes dead product - not available*

ITEM #	PART #	DESCRIPTION
27	160-1495	Stainless Steel Air Guide
28	140-1152	Glass (2 used)
29	160-1394	Glass Clips (2 needed per door)
30	500-4237	Front Handle Stub Nickel with Shaft
31	500-4024	Pawl Ass'y (pawl,set screw,striker bolt & nuts)
32	120-0436	Striker Bolt
33	120-3290	Nut, Jam Large Hex
34	120-0417	¼ -20 x ¼" Pawl Set Screw
35	500-4265	Damper Handle Stub Nickel with Set Screw
36	120-2479	Damper Washer
37	160-0852	Damper Rod
38	120-1583	Fireback Tab (Weld Screw)
39	120-1899	Bottom Hole Plug (remove for coal conversion)
40	120-1338	¼ -20 x ½" Black Hex Head Cap Screw Gr 5
41	120-1432	3/8-16 x 1" Hex Head Cap Screw Leg Bolt
	500-5807	Leg Bolt Package (bolts, washers, tool holder)
42	120-1010	Thermostat Cover Screw 10-24 x 1½" Screw
43	120-0900	¼ -20 x ¾" Black Phillips Round Head Screw
44	120-1960	Ball Chain (per foot)
45	120-1846	Tension Spring
46	000-5801	Thermostat Flap
47	160-1555	Damper Flap Pin
48	30002229	¼ -20 Flex Lock Hex Head Nuts
49	120-0980	10-24 x ¼" Phillips Pan Head Screw
50	120-0563	5/16-18 x 5/16 Socket Set Screw
51	120-3126	Fireback Tab Acorn Nut
52	160-0650	Threaded Nickel Lifter (Nub) Only
53	160-0620	Ceramic Handle (Ceramic Part Only)
54	120-1294	Ceramic handle Screw Only
52-54	000-4342	Nickel Fallaway Handle Complete (52-54)
55	120-0998	10-24 x ½" Phillips Trs Hd Heat Shield Screw

INTREPID COAL STOVE MODEL 1315 & COAL KIT

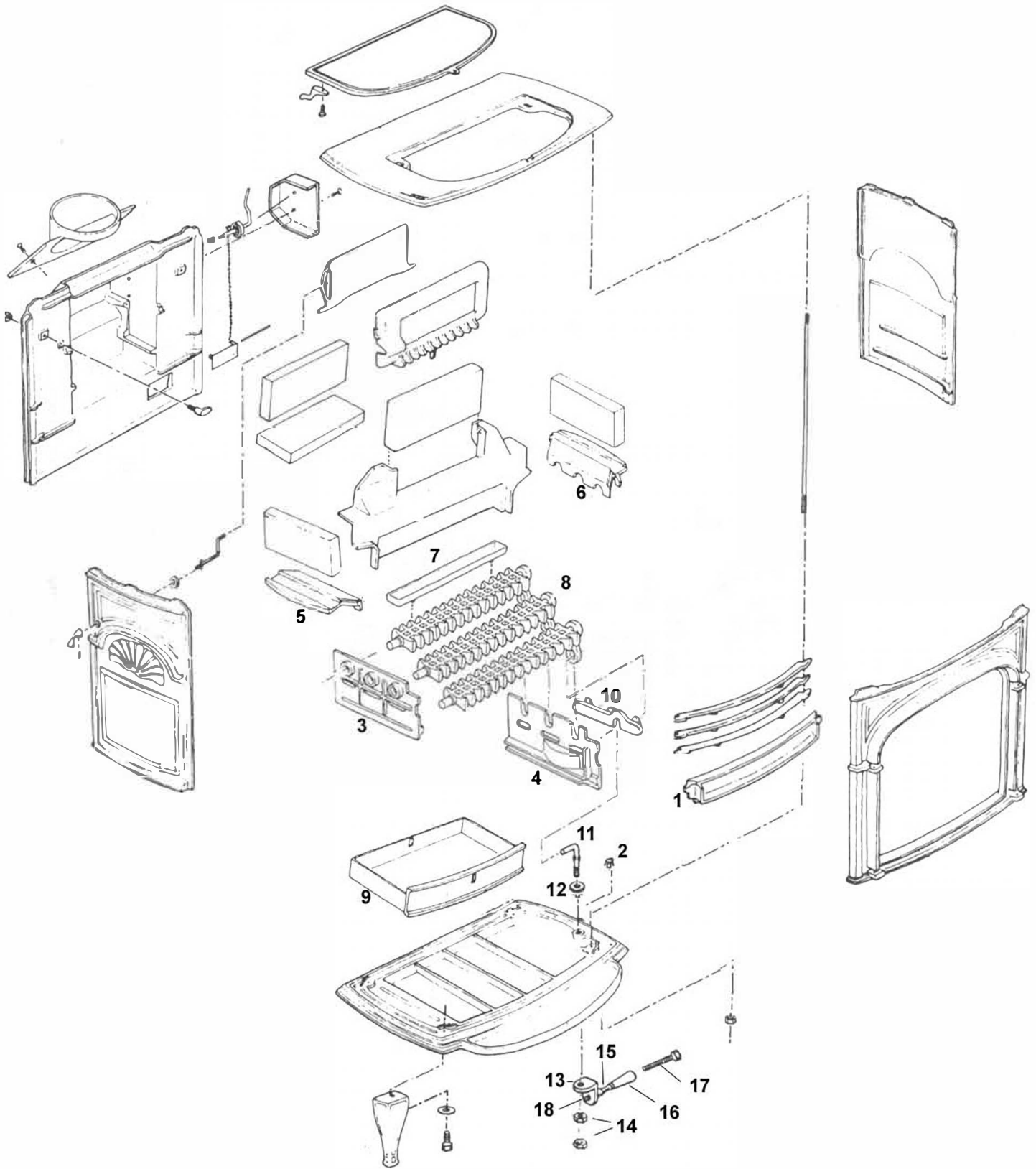

INTREPID COAL STOVE

MODEL #: **1315 INTREPID COAL STOVE**
ALSO SOLD AS A COAL CONVERSION KIT

ITEM #	PART #	DESCRIPTION
1	130-6517	Front Grate
2	120-1899	Shaker Hole Plug
3	130-6546	Left Vertical Grate
4	130-6553	Right Vertical Grate
5	130-6528	Left Horizontal Insert
6	130-6534	Right Horizontal Insert
7	130-6557	Bottom Grate Insert
8	500-3720	Bottom Shaker Grate with Arms Welded
9	500-3540	Coal Ash Pan
10	130-6581	Shaker Linkage
11	160-0922	Shaker Rod
12	120-2560	Washer, $\frac{3}{8}$ " Narrow
13	130-6613	Shaker Connector
14	120-3290	Nut, Jam Large Hex
15	160-0876	Shaker Handle Stub
16	160-0620	Ceramic Handle Only
17	120-1294	$\frac{1}{4}$ -20 x $3\frac{3}{8}$ " Slot Oval Head Handle Screw
18	120-1159*	$\frac{3}{8}$ -16 x $\frac{3}{4}$ " Round Head Slot Screw

Shell Enamel Parts - Intrepid I Model 1302

ENAMEL SHELL PARTS IN GRAY, CHOCOLATE BROWN, ANTIQUE GREEN & ANTIQUE BROWN ARE NO LONGER AVAILABLE

* indicates dead part

Part Name	Old Red	Sand	Blue	Midnight
Top	1318657*	1328657	1338657	1348657*
Bottom	1316764	1326764	1336764	1346764*
Back	1316416*	1326416*	1336416*	1346416*
Left Side	1316428*	1326428*	1336428*	1346428*
Right Side	1316324*	1326324*	1336324*	1346324*
Flue Collar	1316561	1326561	1336561	1346561
Front w/ Doors	5006087*	5006091*	5006096*	5006104*
Left Door Only	N/A	1328649	1338649	N/A
Right Door Only	N/A	1328648	1338648	N/A
Thermostat Cover	1316399	1326399	N/A	1346399*
Single Leg	1316333	1326333	1336333	1346333

GASKETS

120-3588	5/16" Medium Density 6ND Gasket	3'	Left Door
		2.2'	Right Door
120-3668	5/16" Gasket Wire Fiberglass with Core	3.6'	Top for Griddle
120-3560	1/4" Low Density 3ND Gasket	2.5'	Flue Collar
120-3556**	3/16" 4 ND Black Fiber Glass Gasket	1.75'	Each Glass

**000-3427 Glass Gasket Kit c/w enough gasket and cement to regasket both doors.

ACCESSORIES

Heat Shields

160-1755	1 1/4" Spacer Used on Rear
000-5834	Spacer Hardware Kit – Set of 4-160-1755
120-1621	Wing Screw for Bottom HS
120-4015	C-Clip for Bottom HS
000-5802	Hardware Kit for Bottom HS Includes 4-120-4015 & 4-120-1621

Warming Shelf

ENAMEL SHELF PARTS IN GRAY, CHOCOLATE BROWN, ANTIQUE GREEN & ANTIQUE BROWN ARE NO LONGER AVAILABLE

160-1705	Mittenrack
30000967	Hardware Package

Part Name	Classic	Sand	Blue	Midnt
Shelf	1302254	1322254	1332254	1342254
Shelf Bracket	1302272	1322272	1332272	1342272

INTREPID DRILL AND TAP GUIDE EXPLODED VIEW KEY

DIAGRAM	TO ACCOMODATE THIS HOLE USE:	DRILL SIZE	TAP SIZE
A	Flue Collar Screw Holes (2)	5/16"	
B	Pipe Screw Holes (2)	3/16"	
C	Flue Collar Holes (2)	13/64"	1/4 - 20
D	Damper Pin Holes (2)	1/8"x3/32" deep	
E	Heat Shield Holes (4)	#22	10-24
F	Thermostat Hole	#22	10-24
G	Thermostat Cover Hole	#22	10-24
H	Fireback Bolt Holes (2)	"W"	
I	Tie Rod Holes (4)	13/64x16/32 deep	1/4-20
J	Accessory Holes (4)	13/64x16/32 deep	1/4-20
K	Damper Hole	"W"	
L	Tie Rod Holes (4)	5/16"	
M	Leg Bolt Holes (4)	5/16"	3/8-16
N	Shaker Handle Hole	3/8"	
O	Quadrant Screw Hole (2)	13/64x16/32 deep	1/4-20
P	Glass Clip Screw Hole (2)	#22x14/32 deep	10-24
Q	Air Guide Screw Hole	#22x14/32" deep	10-24

DISASSEMBLY OF INTERIOR CASTINGS

Preparation

Place a drop cloth under and around the stove to catch dust and ashes. Remove the griddle (1) and front doors (7,8). It is not necessary to disconnect the chimney connector, though this would be an ideal time to inspect and/or clean the chimney.

Have a good light source or drop light nearby to illuminate the inside of the stove.

Remove the Grates and Airtubes

One at a time, lift the three grate bars (20) upward and out the front door opening. Remove the ash pan (21). Lift out the bottom wood grate (19). Remove the left (18) and right (17) air tubes by lifting them straight upward.

Remove the Firebacks and Damper

Loosen the set screw in the damper handle (35) and remove the handle. Slightly loosen the acorn nuts (38) on the stove back with the 5/8" wrench. Holding the upper fireback (15) in place, turn the L-shaped weld screws (38) upward to release the upper fireback. Lift the upper fireback and damper (14) out toward you.

Remove the damper rod (37) and flat washer (36). Remove the two visible firebricks (24) sitting on top of the lower fireback (16). Lift the lower fireback upward, about 1/2", pull it forward and remove. Remove the remaining horizontal firebrick (24).

THIS COMPLETES THE DISASSEMBLY OF THE INTERIOR CASTINGS. Clean the stove body and interior castings of soot and ashes prior to reassembling the stove.

ASSEMBLY OF INTERIOR CASTINGS

WOOD STOVE

Replace Damper and Firebacks

Lay the horizontal firebrick in place as shown in Figure 1. Replace the lower fireback. The front edge of the horizontal firebrick rests on the appropriate rib on the back of the lower fireback. Be sure the fireback is set securely down into the channel in the bottom. Set the two vertical firebricks in place. Figure 2.

Slide the washer over the straight end of the damper rod. Insert this end through the appropriate hole in the left end, from inside the stove body. Holding the damper rod (yourself, or with an assistant) with the offset end pointing upward, angle the damper into place so the slot in the damper slips over the damper rod. Set the damper flat on the firebricks and locating the the tab, placing the damper pins against the pivot mounts in the back plate of the stove.

Tilt the upper fireback into position, angling the brick retainer over the front firebrick. Reaching through the opening in the upper fireback (if you have disconnected the chimney connector, you can hold the damper through the flue opening), hold the damper in place in its pivots and press the upper fireback into place to rest on the ribs beside the weld screws. Still holding the upper fireback, lay the damper on top of the locating tab and slide the weld screws over the tabs on the upper fireback. Hand-tighten the acorn nuts on the weld screws.

Replace the Airtubes and Grates

Slide the left and right airtubes into their appropriate channels: the curved extensions slide in-between the guides beside the front door opening. Set the bottom grate on top of the left and right airtubes. Replace the three grate bars: they sit almost flat, held in place by the tie rods. Replace the ash pan.

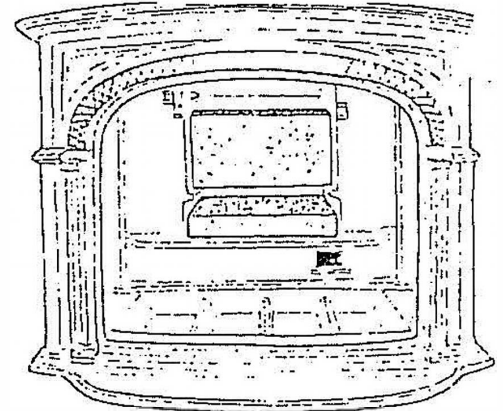

FIG. 1 POSITION OF FIREBRICKS

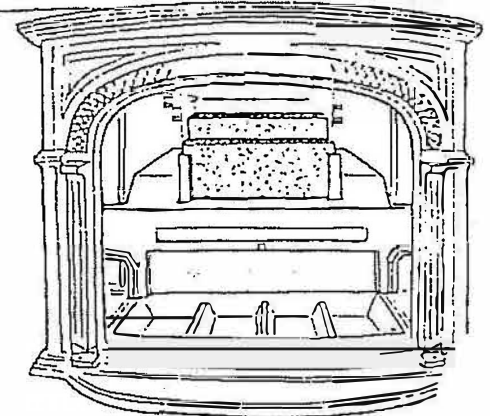

FIG. 2 POSITION OF FIREBRICKS AND LOWER FIREBACK

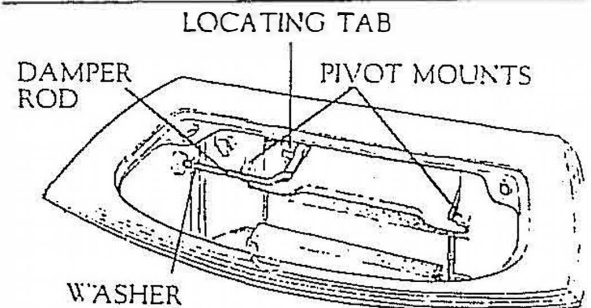

FIG. 3 POSITION OF DAMPER AND DAMPER ROD

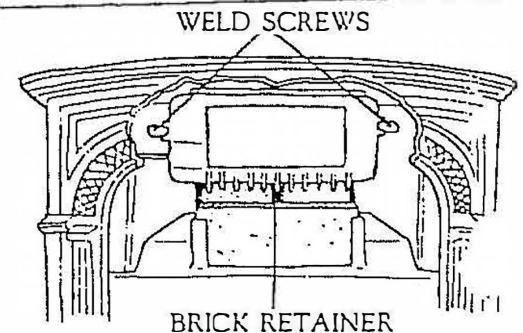

FIG. 4 POSITION OF UPPER FIREBACK

INTREPID COMPLETE REFURBISHING DISASSEMBLY OF EXTERIOR CASTINGS

Preparation

Lift the stove up onto wood or cement blocks so the legs are off the floor. Remove the four leg bolts (41) with the 9/16" wrench. Remove the flue collar (10), thermostat cover (11), and thermostat assembly (23); you may have to bend the thermostat lever slightly. Remove all interior plates as instructed in Section 1, page 4.

Remove the Tie Rods and Top Plate

Remove each of the tie rod nuts (25) with a 7/16" socket or open end wrench. Tie your rope loosely around the stove body. Tap upward with the rubber mallet or hammer and block of wood around the top plate (2) to break the cement seal. Lift off the top plate with the tie rods (25) attached. Drop some penetrating oil where each tie rod joins the top plate and let it set for a few minutes. With the vise grips, carefully unscrew each tie rod from the top plate. You want to avoid the possibility of breaking off a tie rod inside the top plate.

Remove Exterior Castings

Tap and lean the front plate (6) forward and remove. Tap and lean one end plate (4,5) outward and remove. Loosen and lift out the back plate (9) and the other end plate.

The cast plate should be cleaned of furnace cement and ash. Pay particular attention to the cement channels using a hammer and cold chisel or screwdriver. Wear protective eye glasses. Wipe the cement channels with a damp cloth to remove dust particles that may prevent the new cement from adhering.

ASSEMBLY OF EXTERIOR CASTINGS

Preparation

Lay all the stove parts out on the floor in sequence. If you are replacing an exterior casting, we recommend that you reassemble the stove once without cement to make sure all parts fit. All instructions in BOLD concern cementing steps for the permanent assembly. Follow the non-bold instructions for the dry assembly.

Cementing Tips:

- * Be generous with the cement. Run a thick bead in each channel, placing extra cement in the corners of the top and bottom plates.
- * The cement is water soluble so clean-up is easy. When the reassembly is complete, run a putty knife along all the outside seams to remove any excess cement. Then wash the seams with a sponge and warm water and dry with a cloth.
- * Let the cement dry for 24 hours before lighting any fires.

CEMENT THE EXTERIOR CASTINGS

Set the bottom plate on wooden or cement blocks, allowing sufficient clearance to replace the legs at the end of the reassembly.

TAPE THE LEG BOLT HOLES IN THE BOTTOM PLATE WITH MASKING TAPE TO PREVENT THEM FROM FILLING WITH FURNACE CEMENT.

-CEMENT THE FOUR APPROPRIATE CHANNELS ON THE BOTTOM PLATE.

-CEMENT THE SIDE CHANNEL IN THE RIGHT END, THE SIDE CHANNEL IN THE LEFT END, AND BOTH SIDE CHANNELS IN THE FRONT PLATE.

Install the Exterior Castings

Set the back plate in place in the rear channel. Support it with a wooden block. Set the right end in place, moving the back to fit in the correct channel in the right end. Set the left end in place, fitting the channel over the edge of the back plate. Set the front in place and press it over the edges of the right and left ends. Tie a rope tightly around the body of the stove. With a rubber mallet or hammer and block of wood, tap all edges and corners to set the exterior castings in place. Tighten the rope.

NOTE: During the permanent assembly using cement, you may wish to assemble the interior castings before you install the top plate and tie rods. However, the front grate (49) and grate bars (20) will have to be installed after the top and tie rods are installed.

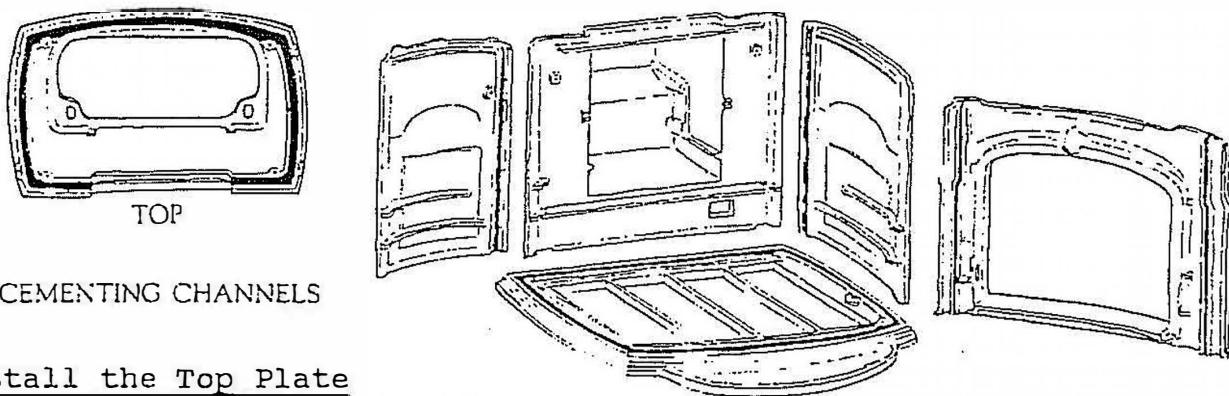

FIG. 7 CEMENTING CHANNELS

Install the Top Plate

SET THE FOUR TIE RODS IN PLACE THROUGH THE HOLES IN THE BOTTOM WITH THE LONGER THREADED ENDS POINTING DOWN. THE TIE RODS CAN REST ON THE FLOOR WHILE THE TOP IS BEING REPLACED.

CEMENT THE FOUR CHANNELS IN THE TOP PLATE.

Set the top plate in place using the rubber mallet or hammer and block of wood to tap around the top edge. Make sure that all plates are set securely into the channels in the top plate.

INSTALL THE TIE RODS

THREAD THE TIE RODS INTO THE TOP PLATE AND HAND-TIGHTEN.
THREAD THE NUTS A FEW TURNS ONTO THE BOTTOM OF THE TIE RODS.

WITH VISEGRIPS, HOLD THE END OF THE TIE ROD AND TIGHTEN THEM FURTHER INTO THE TOP PLATE. TIGHTEN THE NUTS WITH A 7/16" DEEP SOCKET OR OPEN END WRENCH. REPEAT THIS ALTERNATE TIGHTENING WITH EACH NUT. WHEN THE TIE ROD FEELS SECURE, WRENCH THE PROTRUDING END BACK AND FORTH WITH THE VISEGRIPS TO BREAK IT OFF BELOW THE NUT. (THIS STEP IS NECESSARY TO ALLOW THE REPLACEMENT OF THE LEGS). REPEAT FOR THE OTHER THREE TIE RODS.

Replace the Interior Castings

If you have not already done so, see interior assembly instructions in this manual for the Assembly of the Interior Castings.

Finishing

Replace the legs.

Replace the front doors.

Paint the stove, if necessary, after covering all handles and the front door glass.