

Replace the two fixing screws as indicated.

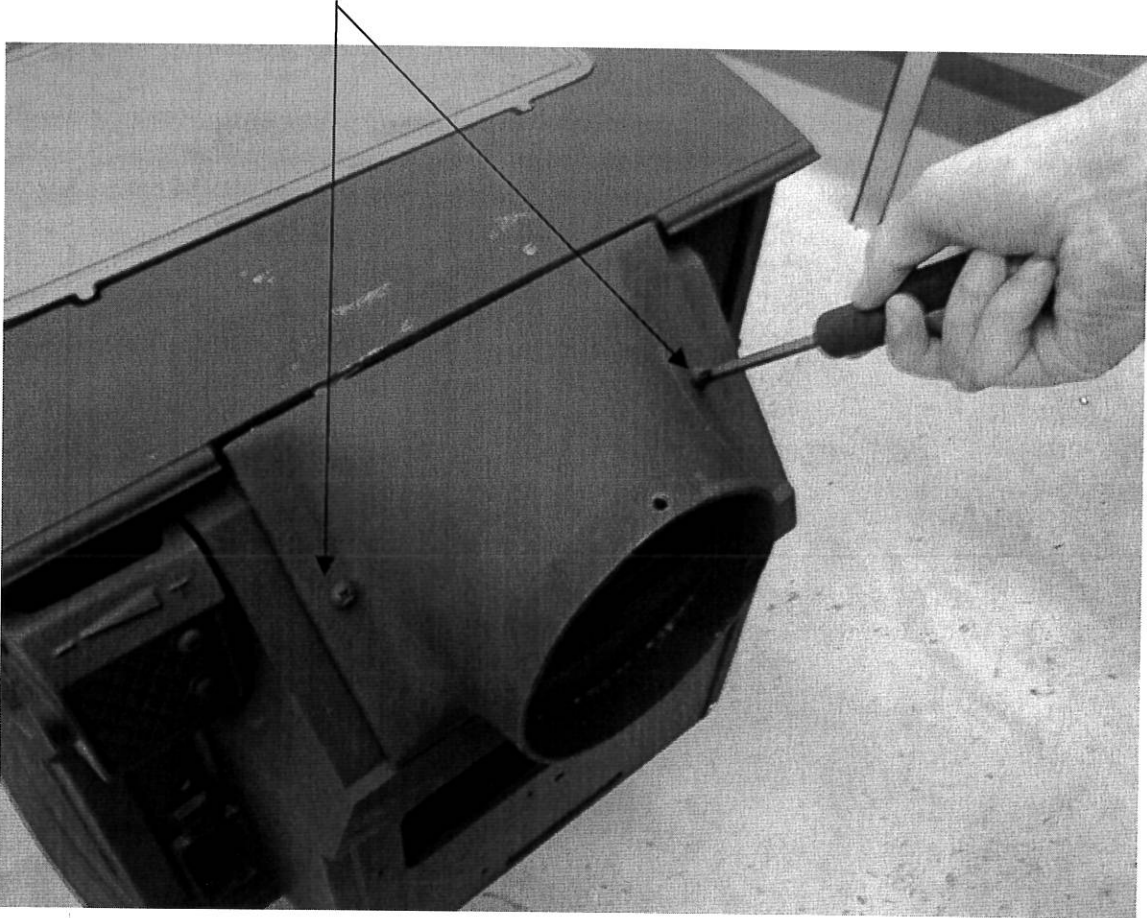

2.8) MAKING THE GAS CONNECTION

IMPORTANT NOTE : BEFORE BREAKING INTO THE GAS SUPPLY, A PRESSURE DROP TEST SHOULD BE CARRIED OUT TO ESTABLISH THAT THE EXISTING PIPEWORK IS SOUND.

The gas connection should be made to the appliance inlet elbow using 8mm rigid or semi-rigid tubing. An isolating elbow or gas cock must be fitted to the pipe work.

Before making the final gas connection, thoroughly purge the gas supply pipe work to remove all foreign matter, otherwise serious damage may be caused to the gas control valve on the fire. Failure to comply with this procedure will invalidate the guarantee.

2.9) GAS SOUNDNESS AND BURNER PRESSURE

- a) Remove the pressure test point screw from the inlet elbow and fit a manometer.
- b) Turn on the main gas supply and carry out a gas soundness test.
- c) Depress the control knob and turn anti-clockwise to the position marked pilot. The pilot should ignite, if it fails to ignite continue to hold in the control knob for a few seconds to purge the pipe work then repeat the ignition. After the pilot has ignited continue to hold in the control for a few seconds and release. Turn the control knob to the full position, the burner should light.
- d) Check that the gas pressure is 20 mbar (+/- 1.0mbar)
8.0 in w.g.(+/- 0.3 in w.g.) for Nat gas and (37mbar+/-1.0mbar LPG)(14.8 +/- 0.4 inw.g.) for Propane, with the stove running.
- e) Turn off the stove, remove the manometer and refit the pressure test point screw. Check the pressure test point screw for gas soundness with the appliance turned on using a suitable leak detection fluid or detector.

SECTION 3

ASSEMBLING THE CERAMICS AND FUEL BED

a) Place the insulating mat centrally on to the fuelbed support then place the hard ceramic base on top of the insulating mat, and pull both fully forwards to the burner. Make sure that the ceramic base is located centrally. **Ensure that both parts fit fully down onto the support and are not lodged on the burner. See below.**

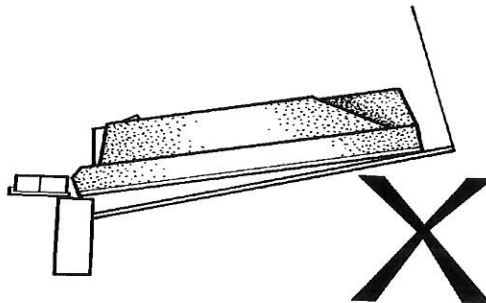
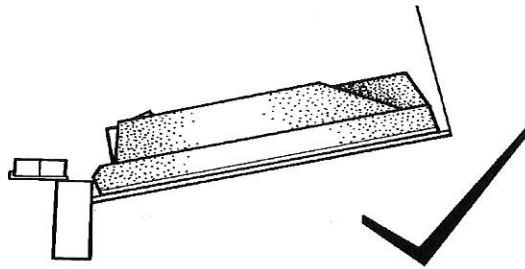
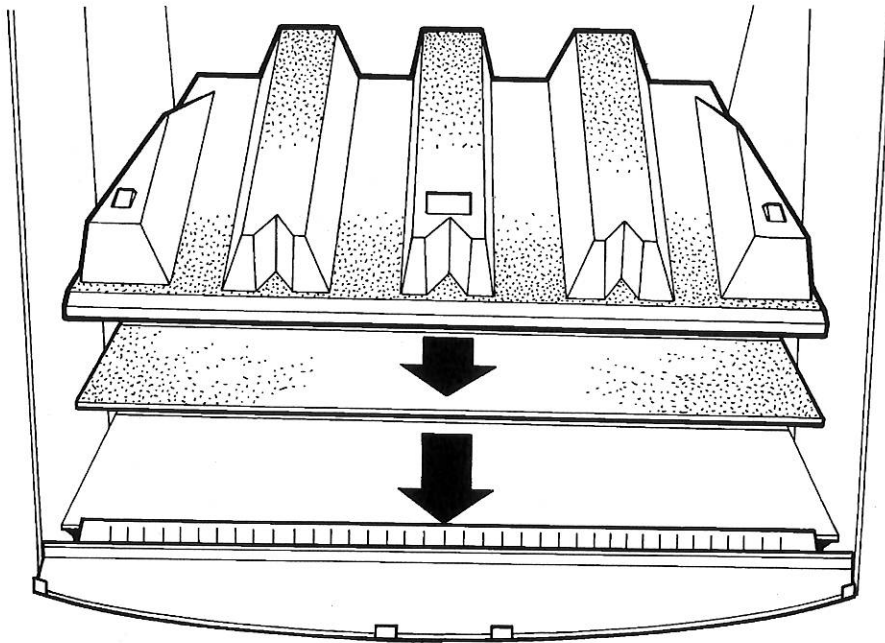

- b) Place both the hard ceramic fuel bed sections on to the base so that the location lugs fit snugly into the recesses on the fuel bed sections.

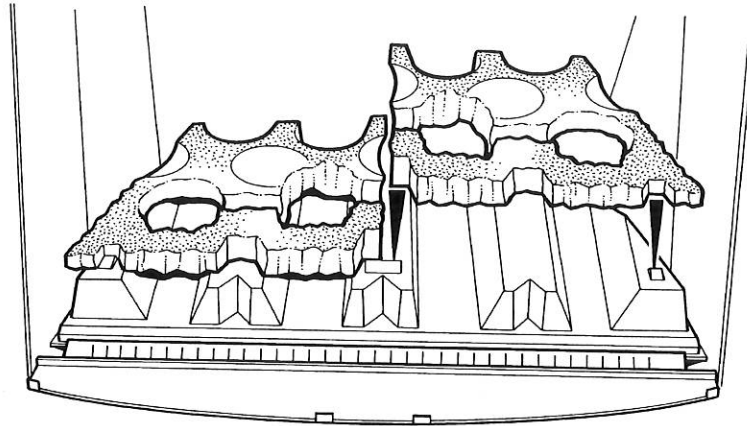

- c) Place the Front Ceramic Rails centrally onto the Semi-Circular location plate situated at the front of the burner. Ensure that the front ceramic rails are located over the front edge. (see below)

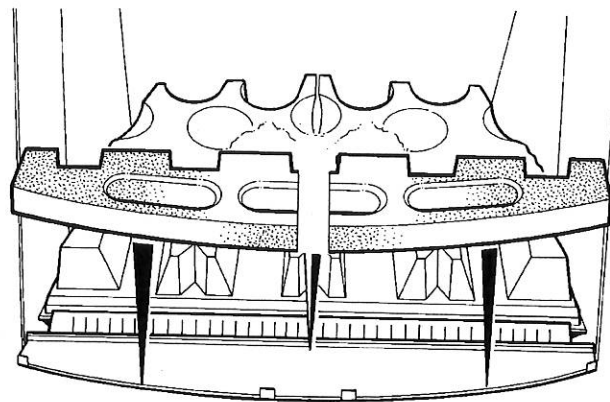

- d) Select five of the large coals and locate each one centrally into the depressions in the Front Ceramic Rail. Ensure that the coals are equally spaced as shown below.

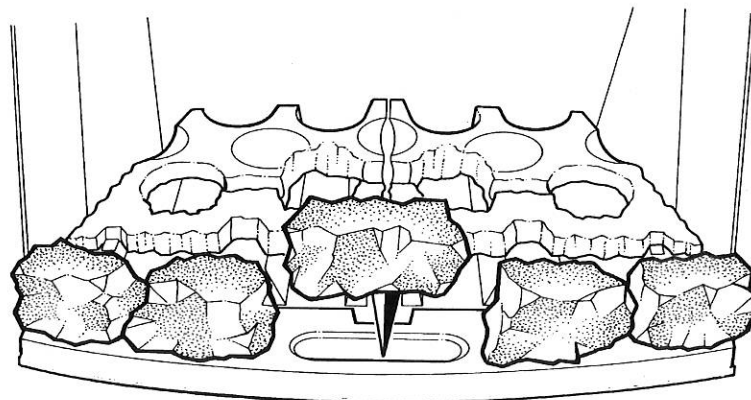

e) Select four of the large coals and two small coals, and place them on the front of the fuel bed directly behind the spaces between the front row of coals.

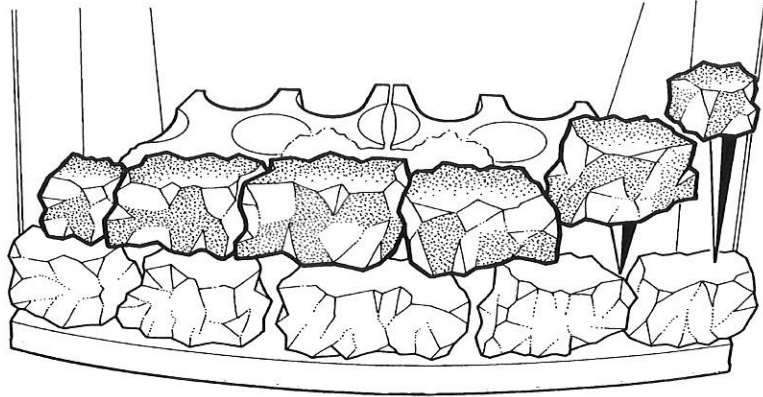

f) Place a row of five coals to occupy the spaces behind the second row of coals.

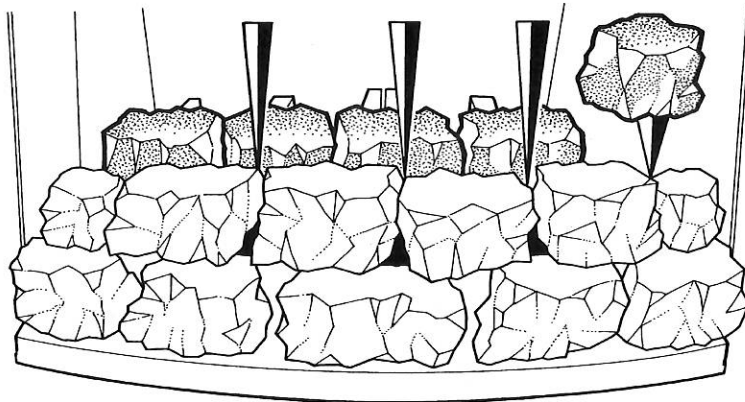

g) Place the remaining four large coals as shown below (Taking care not to allow the coals to be trapped behind the fuelbed):-

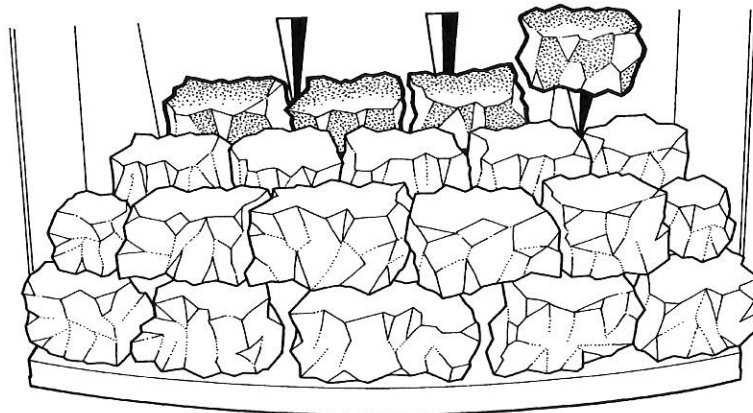

h) Place the remaining three small coals as shown below:-

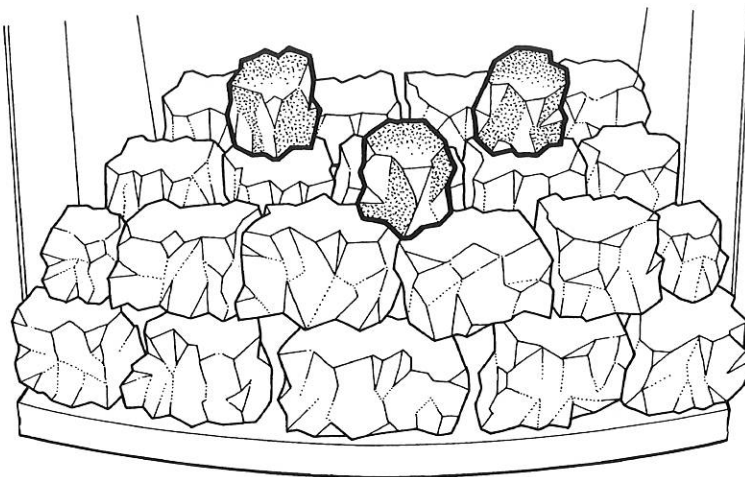

i) Finally, shut the doors on the stove. Once the doors have been shut the handle should be facing downward or similar.

The exact position and fit of the coals may be finely adjusted to give the most pleasing and random appearance.

Warning: Use only the coals supplied with the stove. When replacing the coals remove the old coals and discard them. Fit a complete set of coals of the correct type. Do not fit additional coals or any coals other than a genuine replacement set.

3.2 LIGHTING THE APPLIANCE

- a) Turn on the gas isolation tap.
- b) Depress the control knob and turn anti-clockwise to the position marked pilot. Hold in the control knob for a few seconds to purge the pipe work.
- c) Repeat until the pilot ignites. (located to the lower left window). Continue to hold the control knob for 5-10 seconds to allow the thermocouple to heat up, if the pilot goes out when the control knob is released, repeat the lighting sequence.
- d) Turn the control knob in the anti-clockwise direction to the high position and the main burner will light.
- e) Turn the control knob clockwise to the low position and the gas input will be reduced to the minimum setting.
- f) Slightly depress the control knob and turn to the pilot position, the main burner will go out but the pilot will remain lit.
- g) Slightly depress the control knob and turn to the off position, the pilot will now be extinguished.

3.3 CHECKING FOR CLEARANCE OF COMBUSTION PRODUCTS

- a) Close all doors and windows in the room.
- b) Light the stove and allow to run for approximately 5 minutes on high position.
- c) After approximately 5 minutes hold a smoke match just inside and below the centre of the draft diverter at the rear of the stove (see photo overpage). All smoke generated should be drawn back into the flue. If slight spillage occurs or if in doubt, repeat the test after a further 5-10 minutes.
- d) If spillage persists, the flue is not functioning correctly and a fault exists. If, after investigation the fault cannot be traced and rectified, the stove must be disconnected from the gas supply and expert advice obtained.
- e) If there is an extractor fan fitted anywhere in the vicinity of the appliance, the test should be repeated with the fan running on maximum and all interconnecting doors open.
- f) After ensuring that the stove is safe to use it should be left on high position to fully warm up. During this time a slight odour may be noticed, this is due to the "newness" of the stove and will soon disappear.

Finally, hand the instructions over to the customer and explain the operation of the stove.

Position of Smoke Match for Spillage Check – Section (c) page 27



SECTION 4

MAINTENANCE

Servicing Notes

- Servicing should be carried out annually by a competent person such as a CORGI registered engineer.
- Inspect the general installation of the appliance.
- Isolate the gas supply before working on the appliance.
- Check the condition of the door gaskets.
- The condition of the coals should be checked and **if necessary the whole set should be replaced with a genuine replacement set.**
- Carefully remove the fuelbed and brush away any debris.

4.1 Removing the burner assembly from the stove.

4.1.1 Use the handle provided to open the stove doors. Remove the loose coals from the fuel bed and front ceramic rail. Remove the front ceramic from the rail. Remove the fuelbed from the fuelbed support. Unscrew the two pozi-driv fixing screws which secure the burner heat shield and remove it from the burner.

4.1.2 Isolate the gas supply and remove the inlet pipe from the inlet elbow. Disconnect the fixing nut from the injector block elbow. Unscrew the two fixing screws from underneath the front of the stove to loosen the burner.

4.1.3 Remove the two fixing screws which secure the pilot assembly to the burner. Lift the burner towards you and then tilt to remove from the stove. Re-assemble in reverse order.

4.2 Removing the control tap from the stove.

4.2.1 Isolate the gas supply and remove the inlet pipe from the inlet elbow.

4.2.3 Loosen and remove the three gas pipe retaining nuts from the control tap and release the end of the gas pipes from the control tap body. Loosen and remove the thermocouple securing nut from the end of the control tap.

4.2.4 Pull the HT lead and control knob from the control valve. Unscrew the control tap locknut from the front of the control panel and remove the control tap.

4.2.5 To refit a control tap, re-assemble in reverse order noting that the control tap locates with a flat in the control panel. Carry out a gas soundness test after reassembly.

4.3 Removing the Oxy-Pilot Assembly

Note: Because this appliance is fitted with an atmosphere sensing 'Oxy-Pilot' it is not possible to replace the thermocouple separately, because the thermocouple position is factory set to a tight tolerance. Any replacement of parts on the pilot requires a complete new pilot assembly.

4.3.1 Remove the burner heat shield from the

4.3.2 Unscrew and remove the thermocouple retaining nut from the end of the control tap and disconnect the ignition lead from the pilot electrode.

4.3.3 Unscrew and remove the two pozi-driv screws which secure the pilot assembly to the burner. Disconnect the two leads which connect the pilot to the spillage detection switch at the rear of the stove. Remove the pilot.

4.3.4 Reassemble in reverse order and carry out a gas soundness test.

4.4 Removing the spillage detection switch.

4.4.1 Disconnect the two leads which connect the switch to the pilot assembly underneath the stove. Unscrew the two fixing screws securing the switch to the draft diverter. Re-assemble in reverse order.

4.5 How to Adjust the Door Latch

Over time, the gasket around the doors will compress, and the latch may need adjustment. To adjust the latch, loosen the small locking nut, extend the striker screw one turn with an allen key. (supplied with stove). And retighten the small locking nut while keeping the striker screw from turning. See diagram. Keep making adjustments a little at a time until the setting is correct.

The front doors of the stove should close securely and tightly, when the handle is in the closed position. When the latch is properly adjusted, there should be a slight resistance as the doors are moved to the completely closed position.

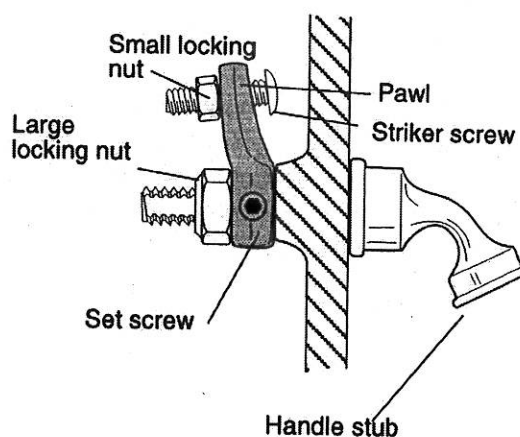

Due to our policy of continual improvement and development the exact accuracy of illustrations and descriptions contained in this book cannot be guaranteed

Part no. 10-39650 Issue 4

VERMONT CASTINGS, INC.

Trentham Lakes

Stoke-on-Trent

Staffordshire

ST4 4TJ

Telephone 01782 339000