

Encore Non-Catalytic Woodburning Stove

Model 1450

Homeowner's Installation and Operating Manual

SAFETY NOTICE: IF THIS APPLIANCE IS NOT PROPERLY INSTALLED, OPERATED AND MAINTAINED, A HOUSE FIRE MAY RESULT. TO REDUCE THE RISK OF FIRE, FOLLOW THE INSTALLATION INSTRUCTIONS. FAILURE TO FOLLOW INSTRUCTIONS MAY RESULT IN PROPERTY DAMAGE, BODILY INJURY OR EVEN DEATH. CONTACT LOCAL BUILDING OFFICIALS ABOUT RESTRICTIONS AND INSTALLATION INSPECTION REQUIREMENTS IN YOUR AREA.

NATIONAL FIREPLACE INSTITUTE
NFI
CERTIFIED
www.nficertified.org

We recommend that our woodburning hearth products be installed and serviced by professionals who are certified in the U.S. by the National Fireplace Institute® (NFI) as NFI Woodburning Specialists or who are certified in Canada by Wood Energy Technical Training (WETT).

Wood Energy Technical Training
www.wettinc.ca

Do Not Discard This Manual: Retain for Future Use

Welcome

Congratulations on your choice of a Vermont Castings Encore. With this purchase you have made a commitment to make the hearth a place of warmth, beauty, and comfort in your home. At MHSC, we share that joy and appreciation for the hearth. You may be assured that your cast-iron Vermont Castings stove has been made with the utmost care and will provide you with many years of service.

As you become acquainted with your new stove or fireplace, you will find that its visual appearance is matched by its functionality, due to cast iron's unique capability to absorb and radiate heat.

Also, MHSC units are among the cleanest-burning wood stoves and fireplaces available today. As an owner of a Vermont Castings stove, you make a strong statement for pollution-free energy. Clean burning, however, depends on both the manufacturer and the operator. Please read this manual carefully to understand how to properly operate and maintain your stove or fireplace.

At MHSC, we are equally committed to your satisfaction as a customer. That is why we maintain an exclusive network of the finest dealers in the industry. Our dealers are chosen for their expertise and dedication to customer service. They are factory-trained and knowledgeable about every MHSC product. Feel free to contact your Authorized Vermont Castings Dealer anytime you have a particular question about your stove or its performance.

This manual contains valuable instructions on the installation and operation of your Vermont Castings stove. It also contains useful information on maintenance and assembly of this product. We urge you to read the manual thoroughly and to keep it as a reference.

Sincerely,

All of us at MHSC

This manual describes the installation, operation, and maintenance of the Vermont Castings Encore Model 1450 non-catalytic wood burning heater. This heater meets the U.S. Environmental Protection Agency's emission limits for wood heaters sold on or after July 1, 1990. Under specific test conditions this heater has been shown to deliver heat at rates ranging from 10,600 to 24,050 Btu/hr.

The Encore Model 1450 has been tested and is safety listed by OMNI-Test Laboratories of Portland, Oregon. The test standards are ANSI/UL-1482 and ANSI/UL-737 for the United States, and ULC S627. The Encore is listed for burning wood. Do not burn other fuels.

The Encore is listed and approved for use in mobile homes in the United States and Canada when installed with Vermont Castings Mobile Home Kit. Refer to and follow the instructions included with the mobile home kit (#0336) to ensure safe installation.

We recommend that you hire a professional installer certified by the Wood Heat Education and Research Foundation (WHERF) or the Wood Energy Technical Training (WETT) to install your stove, or to advise you on the installation should you attempt to install it yourself.

Please read this entire manual before you install and use your new stove. Failure to follow instructions may result in property damage, bodily injury, or even death.

Proposition 65 Warning: Fuels used in gas, wood-burning or oil fired appliances, and the products of combustion of such fuels, contain chemicals known to the State of California to cause cancer, birth defects and other reproductive harm.
California Health & Safety Code Sec. 25249.6

Accessories

Warming Shelves

#0200 Classic Black	#0205 Biscuit
#0201 Bordeaux	#0206 Chestnut Brown
#0202 Sand	#0207 Ebony
#0203 Midnight Blue	#0209 Vt. Classic Green
#0204 Suede Brown	

0127 Sparkscreen

0171 Horizontal Collar Heat Shield

0174 Vertical Collar Heat Shield

3265 Outside Air Kit

0336 Mobile Home Kit

2767 Variable Speed Fan Kit

0168 - 0169 Heat Shields for the Chimney Connector

- Matching Porcelain Stovepipe

- Matching 6" Flue Collar

Table of Contents

Specifications	3
Installation	4
Assembly	18
Operation.....	20
Maintenance.....	27
Replacement Parts.....	31
Warranty.....	35

Specifications

Range of heat output..... 10,600 to 24,050 BTU/hr*
 Maximum heat output.....50,000 BTU/hr**
 EPA emissions ratings, g/hr, non-catalytic.....0.7*
 Area heated*** Up to 1900 sq. ft. (175 sq. m.)
 Fuel size/type20" (508 mm) logs
 Fuel capacity 40 lbs. (18kg)
 Loading..... Front or top
 Chimney connector:
 for 8" oval flue collar..... 8" (203 mm) diameter
 for optional 6" flue collar..... 6" (152 mm) diameter
 Chimney flue size:
 for 8" oval flue collar.....8" (203 mm) minimum
 for optional 6" flue collar.....6" (152 mm) minimum
 Flue exit position Reversible, top or rear
 Primary air Manual control
 Secondary air Fixed, Self-regulating
 Ash handling system Removable ash pan
 Glass panel High-temperature, IR coated ceramic
 Weight 395 lbs. (179 kg)
 Width (leg-to-leg)..... 27" (686 mm)
 Depth (leg-to-leg) 15" (381 mm)
 Height to top of flue collar, (6" or 8")
 Top exit..... 25¼" (641 mm)
 Rear exit..... 26½" (673 mm)

*Under specific conditions used during EPA emissions testing.
 **These values are based on operation in building code-conforming homes under typical winter climate conditions in New England. If your home is of nonstandard construction (e.g. unusually well-insulated, not insulated, built underground, etc.) or if you live in a more severe or more temperate climate, these figures may not apply. Since so many variables affect performance, consult your Vermont Castings' Authorized Dealer to determine realistic expectations for your home.

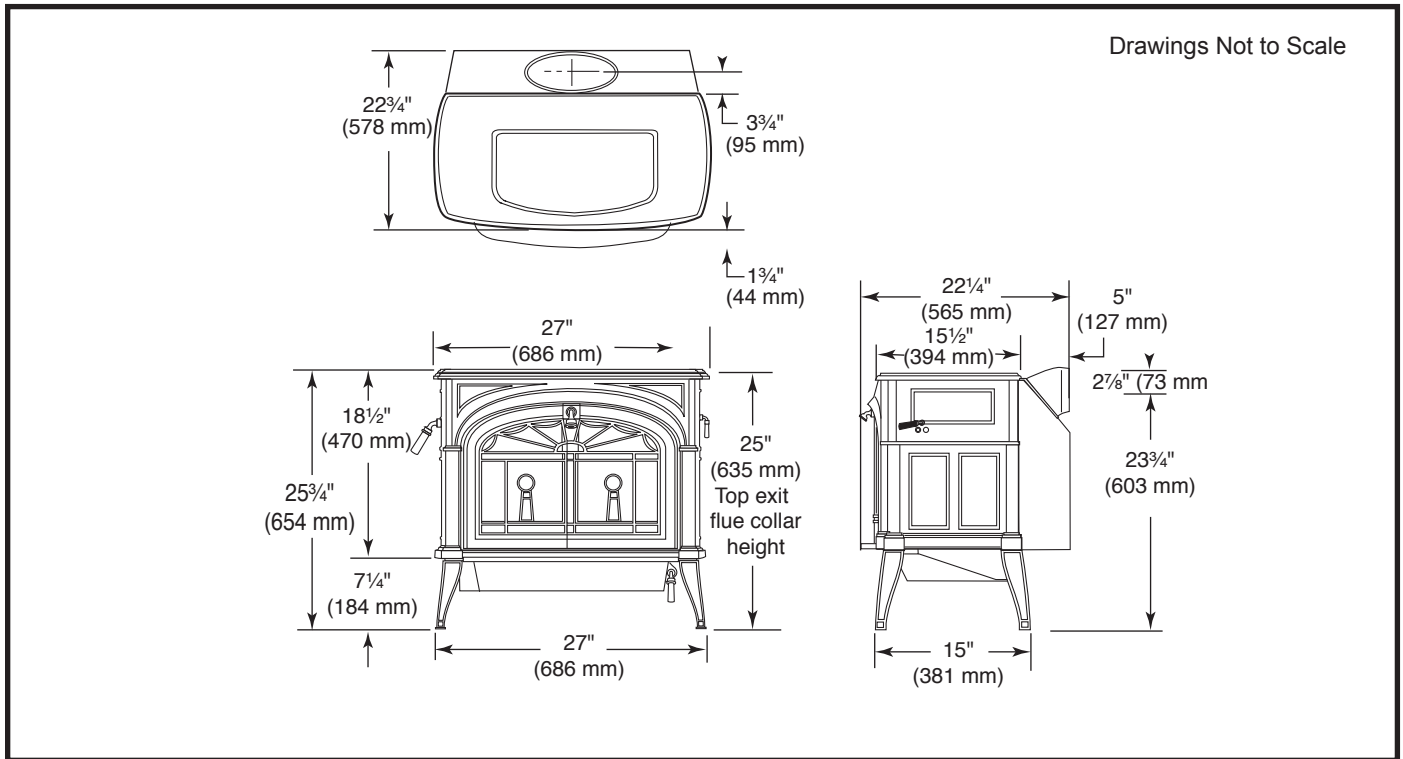

Fig. 1 Encore dimensions.

Installation

SAFETY NOTICE: IF YOUR ENCORE IS NOT PROPERLY INSTALLED, A HOUSE FIRE MAY RESULT. TO REDUCE THE RISK OF FIRE, FOLLOW THE INSTALLATION INSTRUCTIONS. CONTACT LOCAL BUILDING OR FIRE OFFICIALS ABOUT RESTRICTIONS AND INSTALLATION INSPECTION REQUIREMENTS IN YOUR AREA.

Before you begin an installation, be sure that:

- Your stove and chimney connector will be far enough from combustible materials to meet all tested clearance requirements.
- The floor protector is large enough and is constructed properly to meet all tested requirements.
- You have all necessary permits from local authorities.

Your local building official is the final authority for approving your installation as safe and determining that it meets local and state codes.

The metal label permanently attached to the back of every Vermont Castings' stove indicates the stove has been tested and meets current UL and ULC safety standards, and gives the name of the testing laboratory. Clearance and installation information also is printed on the label. When the stove is installed according to the information both on the label and in this manual, local authorities in most cases will accept the label as evidence that the installation meets codes and can be approved.

However, codes vary in different areas. Before starting the installation, review your plans with the local building authority. Your local dealer can provide any additional information needed.

For any unresolved installation issues, refer to the National Fire Protection Association's publication *ANSI/NFPA 211 Standard for Chimneys, Fireplaces, Vents and Solid Fuel Burning Appliances*. For Canada, the equivalent publication is *CSA CAN-B365 Installation Code for Solid Fuel Burning Appliances and Equipment*. These standards are the basis for many national codes. They are nationally recognized and are accepted by most local authorities. Your local dealer or your local building official may have a copy of these regulations.

IMPORTANT: FAILURE TO FOLLOW THESE INSTALLATION INSTRUCTIONS MAY RESULT IN A DANGEROUS SITUATION, INCLUDING A CHIMNEY OR HOUSE FIRE. FOLLOW ALL INSTRUCTIONS EXACTLY, AND DO NOT ALLOW MAKESHIFT COMPROMISES TO ENDANGER PROPERTY AND PERSONAL SAFETY.

Outside Air

In some modern, super-insulated homes, there is inadequate air for combustion because of insufficient air infiltration into the building. Such air enters a home through unsealed cracks and openings. Exhaust fans for kitchen or bath can compete with the stove for available air and compound the problem.

When poor draft is caused by a low infiltration rate, opening a ground floor window on the windward side of the house and in the vicinity of the stove will usually alleviate the problem.

Another solution is to install a permanent outside air supply to the stove and/or room. In fact, bringing air for combustion from outside the home directly to the air inlet of the stove is required for new construction in some areas. The Encore NC is equipped with an outside connection as standard equipment.

Pressure variations within the house do not affect a stove equipped with an outside air supply, and improved stove performance often results. An Outside Air Adapter Kit for the Encore is available from your local Vermont Castings dealer.

Chimney Height

Altitude affects chimney performance. When using a 6" flue collar on the Encore NC, refer to Figure 2 for suggested chimney heights at various altitudes. Chimney height should be measured from the flue collar to the top of the chimney. The recommended minimum chimney height is 16' (4.9 m).

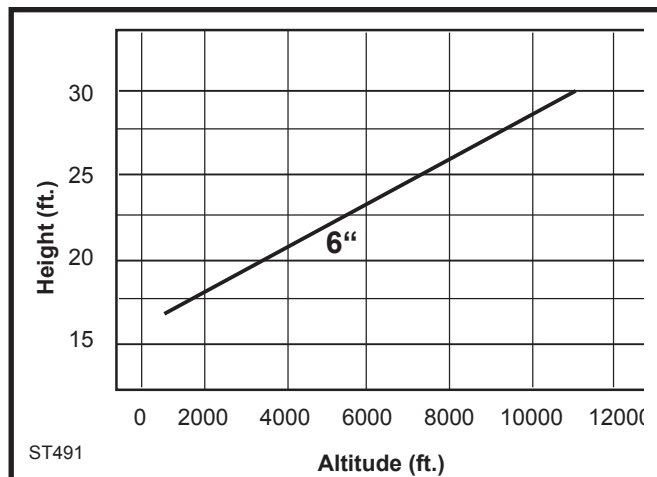

Fig. 2 Chimney height requirements for Encore when equipped with a 6" chimney.

What Kind of Chimney to Use

You must connect the Encore to a code-approved masonry chimney with a flue liner, to a relined masonry chimney that meets local codes, or to a prefabricated metal chimney that complies with the requirements for Type HT chimneys in the Standard for Chimneys, Factory-Built, Residential Type and Building Heating Appliance, UL 103. (Fig. 3) The chimney and chimney connector must be in good condition and kept clean.

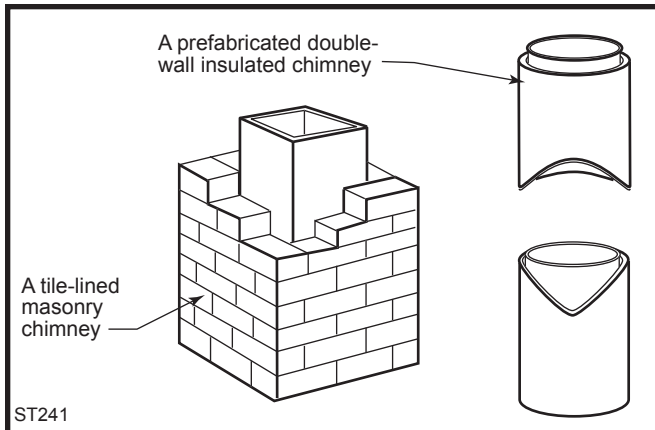

Fig. 3 Approved chimney types.

If you use an existing masonry chimney, it must be inspected to ensure it is in a safe condition before the stove is installed. Your local professional chimney sweep, building inspector, or fire department official will be able to inspect the chimney or provide a referral to someone who can.

The chimney should extend at least 3' (914 mm) above the highest point where it passes through a roof, and at least 2' (610 mm) higher than any portion of a building within 10' (3 m). (Fig. 4)

For proper draft and good performance, any chimney used with an Encore should extend at least 16' (5 m) above the flue collar of the stove.

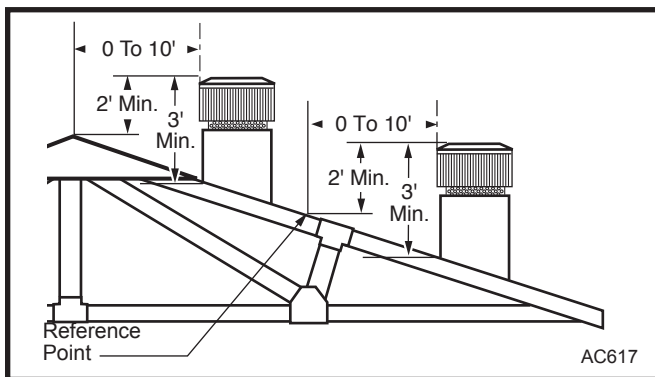

Fig. 4 The 2'-3'-10' Chimney Rule.

Masonry Chimneys

An inspection of the chimney must confirm that it has a lining. Do not use an unlined chimney. The chimney should have no cracks, loose mortar, other signs of deterioration, and blockage. Repair any defects before the chimney is used with your stove.

Unused openings in an existing masonry chimney must be sealed with masonry to the thickness of the chimney wall, and the chimney liner should be repaired. Openings sealed with pie plates or wallpaper are a hazard and should be sealed with mortar or refractory cement. In the event of a chimney fire, flames and smoke may be forced out of these unused thimbles.

The chimney should be thoroughly cleaned before use.

A newly-built masonry chimney must conform to the standards of your local building code or, in the absence of a local code, to a recognized national code. Masonry chimneys must be lined, either with code-approved masonry or pre-cast refractory tiles, stainless steel pipe, or a code-approved, "poured-in-place" liner. The chimney's clean-out door must seal tightly.

Prefabricated Chimneys

A prefabricated metal chimney must be one tested and listed for use with solid-fuel burning appliances to the High-Temperature (H.T.) Chimney Standard UL-103-1985 (2100°F) for the United States, and High Temperature (650°C) Standard ULC S-629 for Canada.

DO NOT CONNECT THIS UNIT TO A CHIMNEY FLUE SERVING ANOTHER APPLIANCE.

Chimney Size

An Encore with an 8" (203 mm) flue collar is approved for venting into a masonry chimney with a nominal flue size of 8" x 8" (203 x 203 mm) or 8" x 12" (203 x 305mm), and into a round flue with nominal flue size of 8" (203 mm). An Encore with a 6" (152 mm) flue collar is approved for venting into a masonry chimney with a nominal flue size of 8" x 8" (203 x 203 mm), and into a round flue with nominal flue of 6" (152 mm).

NOTE: When installed with a 6" flue collar, the Encore may not be operated with the front doors open.

Whatever the flue collar size, an Encore may be vented into larger chimneys as well. However, chimneys with liners larger than 8" x 12" (203 x 305 mm) may experience rapid cooling of smoke and reduction in draft, especially if the chimneys are located outside the home. These large chimneys may need to be insulated or have their flues relined for proper stove performance.

Accessories to help make the connection between stainless steel chimney liners and your Encore are available through your local dealer.

Chimney Connector Guidelines

A chimney connector is the double-wall or single-wall pipe that connects the stove to the chimney. The chimney itself is the masonry or prefabricated structure that encloses the flue. Chimney connectors are used only to connect the stove to the chimney, as in Figure 5.

Double-wall connectors must be tested and listed for use with solid-fuel burning appliances. Single-wall connectors should be made of 24 gauge or heavier steel. Do not use galvanized connector; it cannot withstand the high temperatures that can be reached by the stove's exhaust gases, and may release toxic fumes under high heat. The connector may be 6" (152mm) or 8" (203mm) in diameter.

If possible, do not pass the chimney connector through a combustible wall or ceiling. If passage through a combustible wall is unavoidable, refer to the section on Wall Pass-Throughs. Do not pass the connector through an attic, a closet or similar concealed space. The whole connector should be exposed and accessible for inspection and cleaning.

In horizontal runs of chimney connector, maintain a distance of 24" (610mm) from the ceiling. Keep it as short and direct as possible, with no more than two 90° turns. Slope horizontal runs of connector upward 1/4" per foot (6mm per meter) going from the stove toward the chimney. The recommended maximum length of a horizontal run is 3' (1m), and the total length should be no longer than 8' (2.4m). In cathedral ceiling installations, extend the prefabricated chimney downward to within 8' (2.4) of the stove.

Wear gloves and protective eyewear when drilling, cutting or joining sections of chimney connector.

Single-wall Chimney Connectors

- Begin assembly at the flue collar of the stove. Insert the first crimped end into the stove's flue collar, and keep each crimped end pointing toward the stove. (Fig. 5) Using the holes in the flue collar as guides, drill 1/8" (3mm) holes in the bottom of the first section of chimney connector and secure it to the flue collar with three #10 x 1/2" sheet metal screws.
- Secure each joint between sections of chimney connector, including telescoping joints, with at least three (3) sheet metal screws. The pre-drilled holes in the top of each section of chimney connector serve as guides when you drill 1/8" (3mm) holes in the bottom of the next section.
- Secure the chimney connector to the chimney. Instructions for various installations follow.
- Be sure the stove and chimney connector are installed at the correct distances from nearby combustible materials as per tested clearance. Refer to Encore Clearance Diagrams.

NOTE: Special slip pipes and thimble sleeves that form telescoping joints between sections of chimney connector are available to simplify installations. They often eliminate the need to cut individual connector sections. Consult your local dealer about these special pieces.

Double-wall Chimney Connectors

Information on assembling and installing double-wall connectors is provided by the manufacturer of the double-wall pipe. Follow the manufacturer's instructions exactly as you assemble the connector and attach it to the stove and chimney. Using chimneys and connectors from the same manufacturer makes the assembly and installation straightforward.

NOTE: For installations using double-wall connectors, minimum clearances must conform to the listed clearances in the clearance chart on Page 15.

If the Encore is equipped with the 8" flue collar, an oval-to-round adapter will be needed. Double-wall oval-to-round adapters are available from some manufacturers. Your local dealer can help you select the right connector.

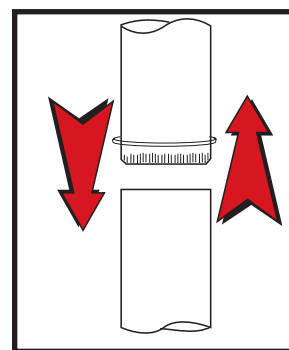

Fig. 5 the crimped end of the connector points toward stove.

Securing the Single-wall Connector to a Prefabricated Chimney

Follow the installation instructions of the chimney manufacturer exactly as you install the chimney. The manufacturer of the chimney will supply the accessories to support the chimney, either from the roof of the house, at the ceiling of the room where the stove is installed, or from an exterior wall.

Special adapters are available from your local dealer which connect the prefabricated chimney to the chimney connector. The top of such adapters attach directly to the chimney or to the chimney's ceiling support package, while the bottom of the adapter is screwed to the chimney connector.

These adapters are designed so the top end will fit outside the inner wall of the chimney, and the bottom end will fit inside the first section of chimney connector. When assembled in this way, any soot or creosote falling from the inner walls of the chimney will stay inside the chimney connector.

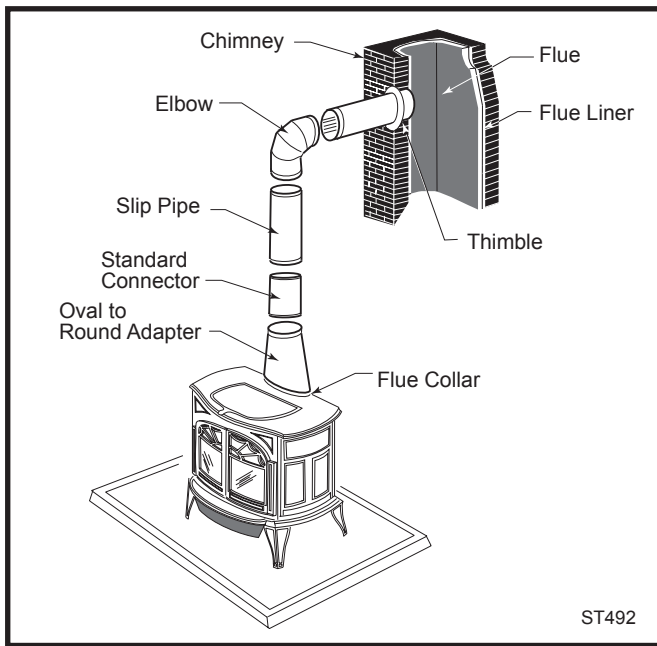

Fig. 6 An exploded view of the chimney connection in a freestanding masonry installation.

Securing the Single-wall Connector to a Masonry Chimney

Both freestanding masonry chimneys and fireplace masonry chimneys may be used for your installation.

Freestanding Installations

If the chimney connector must pass through a combustible wall to reach the chimney, follow the recommendations in the Wall Pass-Through section later in this manual.

The opening through the chimney wall to the flue (the “breach”) must be lined with either a ceramic or metal cylinder, called the “thimble”, which is cemented securely in place. Most chimney breaches incorporate thimbles, but the fit must be snug and the joint between the thimble and the chimney wall must be cemented firmly.

A special piece called the “thimble sleeve,” slightly smaller in diameter than standard connectors and most thimbles, will facilitate the removal of the chimney connector system for inspection and cleaning. Thimble sleeves are available from your local dealer.

To install a thimble sleeve, slide it into the breach until it is flush with the inner flue wall. Do not extend it into the actual flue passage, as this could interfere with the draft.

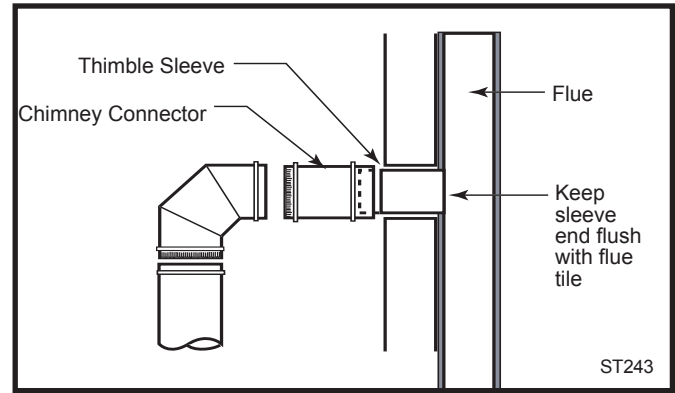

Fig. 7 The thimble, made of either ceramic or metal, must be cemented securely in place.

The thimble sleeve should protrude 1-2” (25-50mm) into the room. (Fig. 7) Use furnace cement and thin gasketing to seal the sleeve in place in the thimble. Secure the chimney connector to the outer end of the sleeve with sheet metal screws.

Without a thimble, a suitable length of chimney connector can be extended through the breach to the inner face of the flue liner, and cemented securely in place. Additional pieces of connector are then attached with sheet metal screws.

Fireplace Installations

The chimney connector may be connected to the chimney above the fireplace opening or through the fireplace.

Above the Fireplace

The Encore may be connected to a chimney above a fireplace opening. (Fig. 8) In such installations, the stove is positioned on the hearth in front of the fireplace and the chimney connector rises from the stove top and then angles ninety degrees back into the chimney. The chimney liner should extend to the point at which the chimney connector enters the chimney.

If the chimney connector from your installation enters the chimney above a fireplace, follow all the guidelines mentioned above for freestanding installations. In addition, give special consideration to the following points:

- Check the clearance between the stove and the chimney connector, and any combustible trim or the mantel. Use the necessary combination of mantel, trim, and connector heat shields to achieve the required clearances.
- Check the clearance between the chimney connector and the ceiling. If no heat shields are used, the clearance should be at least 24” (610mm). To find out how much this clearance may be reduced with heat shields, refer to the clearance chart on Page 15.

- The fireplace damper must be sealed to prevent room air from escaping up the flue. However, it must be possible to re-open the damper to inspect or clean the chimney.

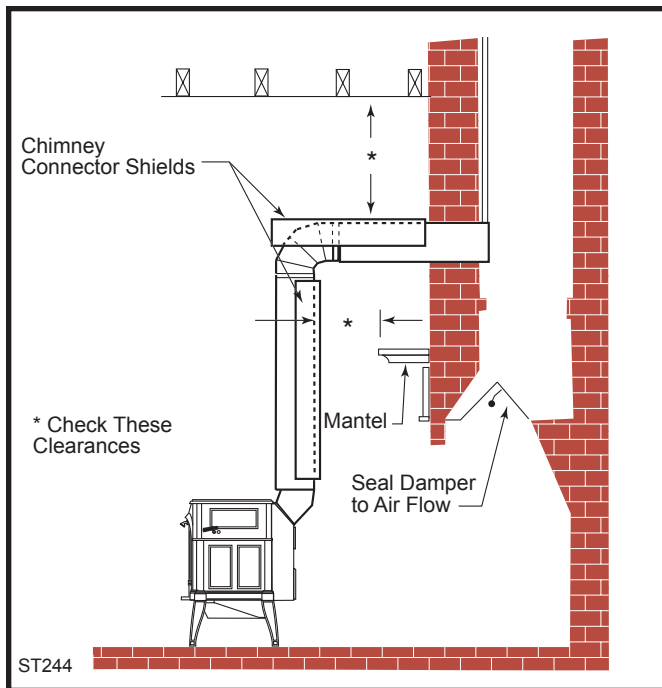

Fig. 8 In this installation, the chimney connector is attached to the chimney above the fireplace opening.

Through the Fireplace

If your fireplace opening height is at least 26½" (675mm), you may install an Encore through the opening using a "positive connection" kit, available from your local dealer. These positive connection kits ensure a tight fit between the stove flue collar and the chimney flue. (Fig. 9)

Fireplace installations, whether connected to the flue above or through the fireplace opening, have special clearance requirements to adjacent trim and the mantel. You'll find the required safe clearances for Encore fireplace installations on Page 12 and Figure 16.

Floor protection requirements also apply to fireplace installations. This information is on Page 10.

Wall Pass-Throughs

Whenever possible, design your installation so the connector does not pass through a combustible wall. If you are considering a wall pass-through in your installation, check with your building inspector before you begin. Also, check with the chimney connector manufacturer for any specific requirements.

Accessories are available for use as wall pass-throughs. If using one of these, make sure it has been tested and listed for use as a wall pass-through.

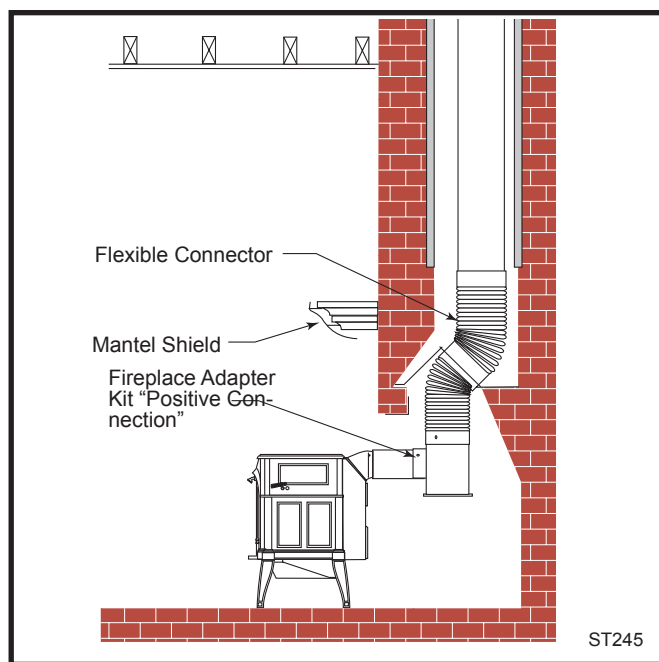

Fig. 9 In this installation, the chimney connector enters the fireplace opening and then connects to the chimney.

In the United States, the National Fire Protection Association (NFPA) has established guidelines for passing chimney connectors through combustible walls. Many building code inspectors follow these guidelines when approving installations.

Figure 10 shows one NFPA-recommended method. All combustible material in the wall is cut away from the single-wall connector to provide the required 12" (305mm) clearance. Any material used to close up the opening must be noncombustible.

Three other methods are also approved by the NFPA:

- Using a section of double-wall chimney with a 9" (229mm) clearance to combustibles.
- Placing a section of chimney connector inside a ventilated thimble, which in turn is separated from combustibles by 6" (152mm) of fiberglass insulating material.
- Placing a section of chimney connector inside a section of 9" (230mm) diameter, solid-insulated, factory-built chimney, with 2" (50mm) of air space between the chimney section and combustibles.

In Canada, The Canadian Standards Association has established different guidelines. Figure 10 shows one method, in which all combustible material in the wall is cut away to provide the required 18" (457mm) clearance for the connector. The resulting space must remain empty. A flush-mounted sheet metal cover may be used on one side only. If covers must be used on both sides, each cover must be mounted on noncombustible spacers at least 1" (25mm) clear of the wall.

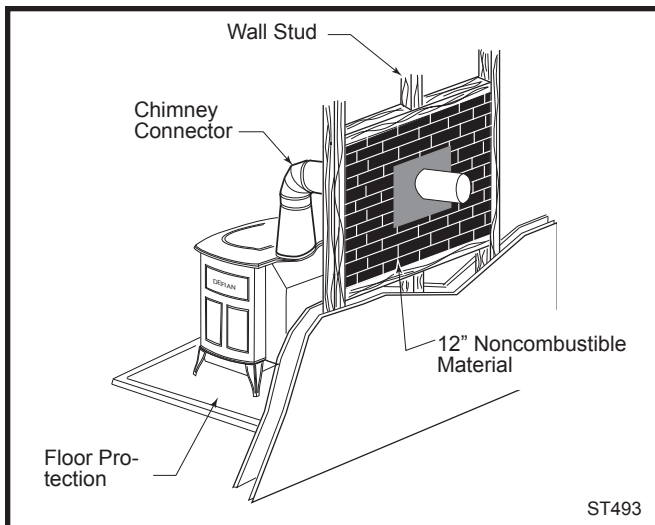

Fig. 10 An approved wall pass-through for the United States.

Your local dealer or your local building inspector can provide details for other approved methods of passing a chimney connector through a combustible wall in your area. In Canada, this type of installation must conform to CAN/CSA-B365, Installation Code for Solid Fuel Burning Appliances and Equipment.

NOTE: Do not vent your Encore into a factory-built (zero-clearance) fireplace. These appliances together with their specific chimneys are designed as a system for use as fireplaces. It may void the listing or be hazardous to adapt factory-built fireplaces for any other use.

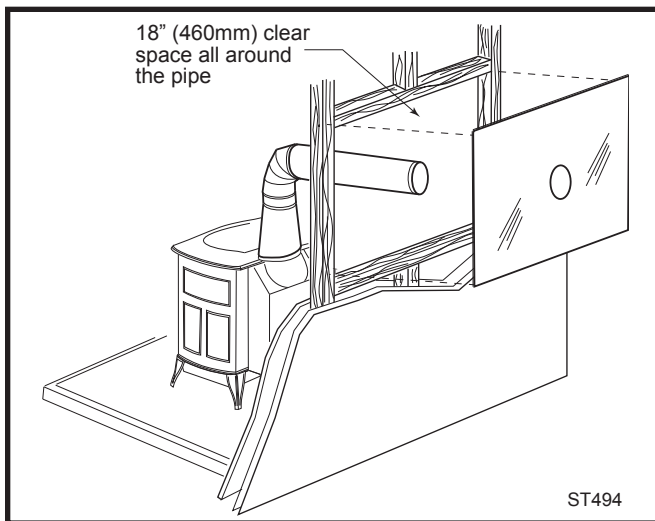

Fig. 11 An approved wall pass-through for Canada.

DO NOT CONNECT AN ENCORE TO ANY AIR DISTRIBUTION DUCT OR SYSTEM.

Floor Protection

A tremendous amount of heat radiates from the bottom plate of your stove. The floor area directly under and around the stove will require protection from radiant heat as well as from stray sparks or embers that may escape the firebox.

Heat protection is provided through the bottom heat shield. Spark, ember and thermal protection must be provided by a floor protector constructed with noncombustible material as specified.

Most installations will require the bottom heat shield be attached. Only when the stove is placed on a completely noncombustible surface such as unpainted concrete over earth may it be used without the heat shield.

Even when the bottom heat shield is installed, you must provide special protection to the floor beneath. For installation with the heat shield attached, use an approved 1/2" (13 mm) noncombustible hearth pad with $k = 0.84$ BTU/in ft² hr °F or an equivalent material with an R-value of at least 0.59. (Refer to "How to Determine if Alternate Floor Protection Materials are Acceptable" section) The floor protector may be covered with a decorative noncombustible material if desired. Do not obstruct the space under the heater.

Protection requirements vary somewhat between the United States and Canada as follows:

U. S. installations the floor protector is required under the stove and must extend at least 16" (not including the ash lip) from the front of the stove ("F", Fig. 12), and at least 6" from the sides and rear. ("D" and "E", Fig. 12) It must also extend under the chimney connector and 2" to either side. ("C", Fig. 12) For the 8" (203 mm) connector, the protector must be a minimum of 12" (305 mm) wide. For the 6" (152 mm) connector, the protector must be 10" (254 mm) wide. The protector must be centered under the connector.

To meet these requirements, a floor protector must be at least 39" wide and 45" deep.

In Canada: A noncombustible floor protector is required under the stove as well. The floor protector must extend 18" (450 mm) to the front ("F", Fig. 12), and 8" (200 mm) from the sides and rear. ("D" and "E", Fig. 12)

To meet these requirements, a floor protector must be at least 43" (1092 mm) wide and 49" (1245 mm) deep.

Floor protection also must extend under the chimney connector and 2" (51 mm) to either side. ("C", Fig. 12) For the 8" (203 mm) connector, the protector must be a minimum of 12" (305 mm) wide. For the 6" (152 mm) connector, it must be at least 10" (254 mm) wide. The protector must be centered under the connector.

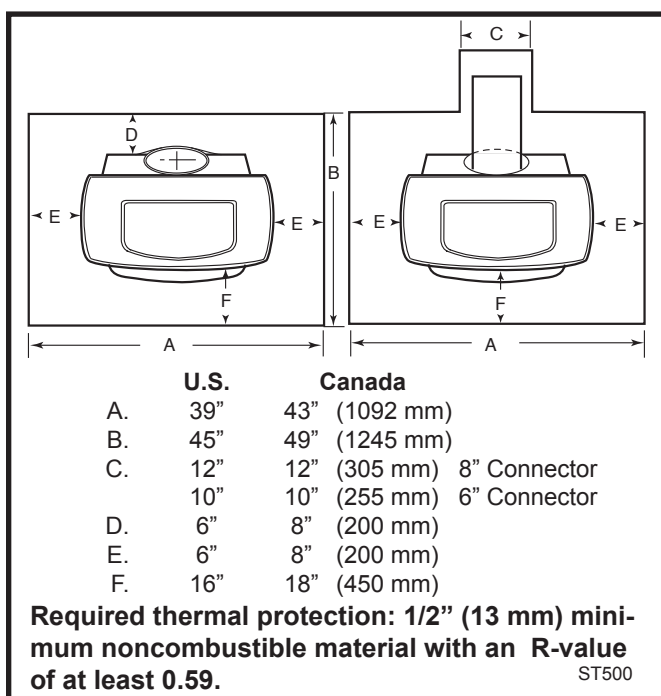

Fig. 12 Required floor protector dimensions for both top and rear-exiting stove.

How to Determine if Alternate Floor Protection Materials are Acceptable

All floor protection must be noncombustible (i.e. metals, brick, stone, mineral fiber boards, etc.). Any organic materials (i.e. plastics, wood paper products, etc.) are combustible and must not be used. The floor protection specified includes some form of thermal designation such as R-value (thermal resistance) or k-factor (thermal conductivity).

Procedure:

- Convert specifications to R-value:
 - R-value given - no conversion needed.
 - k-factor is given with a required thickness (T) in inches: $R = \frac{1}{k} \times T$
 - K-factor is given with a required thickness (T) in inches: $R = \frac{1}{K \times 12} \times T$
 - r-factor is given with a required thickness (T) in inches: $R = r \times T$
- Determine the R-value of the proposed alternate floor protector:
 - Use the formula in Step 1 to convert values not expressed as R.
 - For multiple layers, add R-values of each layer to determine overall R-value.
- If the overall R-value of the system is greater than the R-value of the specified floor protector, the alternate is acceptable.

EXAMPLE: The specified floor protector should be 1/2-inch thick material with k-factor of 0.84. The proposed alternate is 4" brick with an r-factor of 0.2 over 1/8" mineral board with a k-factor of 0.29

Step a: Use formula above to convert specification to

$$R\text{-value: } R = \frac{1}{k} \times T = \frac{1}{0.84} \times 0.5 = 0.59$$

Step b: Calculate R of proposed system.

4" brick of r = 0.2, therefore:

$$R_{\text{brick}} = 0.2 \times 4 = 0.8$$

1/8" mineral board of k = 0.29, therefore

$$R_{\text{mineralboard}} = \frac{1}{0.29} \times 0.125 = 0.431$$

$$R_{\text{total}} = R_{\text{brick}} + R_{\text{mineralboard}} = 0.8 + 0.431 = 1.231$$

Step c: Compare proposed system Rtotal of 1.231 to specified R of 0.59. Since proposed system Rtotal is greater than required, the system is acceptable.

Definitions

$$R = \frac{(\text{ft}^2)(\text{hr})(\text{°F})}{\text{Btu}}$$

$$k = \frac{(\text{Btu})(\text{in})}{(\text{ft}^2)(\text{hr})(\text{°F})} = K \times 12$$

$$K = \frac{(\text{Btu})(\text{ft})}{(\text{ft}^2)(\text{hr})(\text{°F})}$$

$$r = \frac{(\text{ft}^2)(\text{hr})(\text{°F})}{(\text{Btu})(\text{in})} = \frac{1}{k}$$

Floor Protection for Fireplace Installations

Do not assume that your fireplace hearth is completely noncombustible.

Many fireplace hearths do not meet the "completely noncombustible" requirement because the brick or concrete in front of the fireplace opening is supported by heavy wood framing. (Fig. 13) Because heat passes through brick or concrete readily, it can easily pass through to the wood. As a result, such fireplace hearths can be a fire hazard and are considered a combustible floor.

Keep in mind, also, that many raised hearths will extend less than the required clearance from the front of the heater when it is installed. In such cases, sufficient floor protection as described above must be added in front of the hearth to satisfy the minimum floor protector requirement from the front of the stove: 16" (406 mm) from the front in the United States and 18" (450 mm) from the front in Canada.

Hearth rugs do not satisfy the requirements for floor protection.

Fireplace installations also have special clearance requirements to the side walls, side decorative trim, and fireplace mantel. This information follows in the section on Fireplace and Mantel Trim Shields.

Keep the Stove a Safe Distance from Surrounding Materials

Both a stove and its chimney connector radiate heat in all directions when operating, and dangerous overheating of nearby combustible materials can occur if they are too close to the heat. A safe installation requires that adequate clearance be maintained between the hot stove and its connector and nearby combustibles.

Clearance is the distance between either your stove (measured from the bottom edge of the stove's top plate) or chimney connector, and nearby walls, floors, the ceiling, and any other fixed combustible surface. Your stove has special clearance requirements that have been established after careful research and testing to UL and ULC standards. These clearance requirements must be strictly observed.

In addition, furnishings and other combustible materials must be kept away from the stove. In general, a distance of 48" (1219mm) must be maintained between the stove and moveable combustible items such as drying clothes, furniture, newspapers, firewood, etc. Keeping those clearance areas empty assures that nearby surfaces and objects will not overheat.

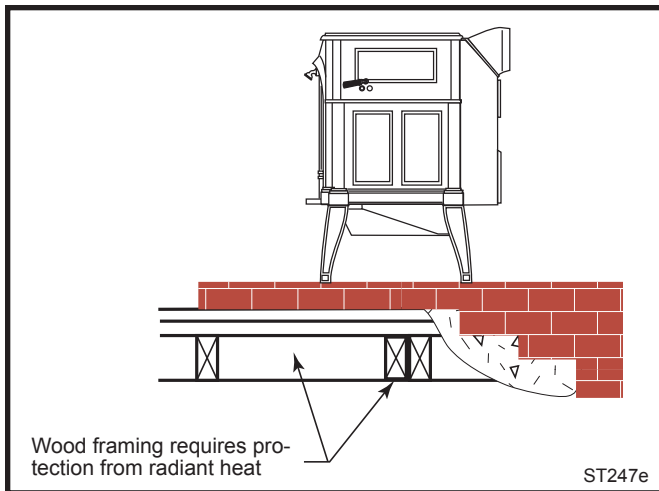

Fig. 13 Combustible supporting timbers may lie beneath fireplace hearths, requiring additional floor protection.

Reducing Clearances Safely with Shields

Clearance requirements are established to meet every installation possibility, and they involve the combination of four basic variables:

- **When the chimney connector has no listed heat shield mounted on it.**
- **When the chimney connector has a listed heat shield mounted on it.**
- **When the wall has no listed heat shield mounted on it.**
- **When the wall has a heat shield mounted on it.**

The Encore 1450 includes a bottom heat shield that is needed in most installations. Refer to Page 9 for more information on required floor protection. In addition, top exit installations that do not include wall protection must include a vertical flue collar heat shield. (Consult clearance chart on Page 15.) The vertical flue collar heat shield is sold as a separate accessory.

In general, the greatest clearance is required when you place a stove and its connector without accessory heat shields near walls without heat shields.

For example, when the Encore is installed parallel to the rear wall and no shields are used, the rear edge of the top must be at least 29" (737 mm) from the wall behind it and at least 17" (432 mm) from walls on either side.

If the Encore is installed in a corner and no shields are used, the corners of the stove must be at least 28" (711 mm) from nearby walls.

The least clearance is required when the connector, as well as the wall, have heat shields or when a double wall connector and wall shields are used.

When shields are attached to the stove or chimney connector, they are mounted away from the stove or connector surface on noncombustible spacers. Air flowing between the stove (and/or chimney connector) and attached shields carries away heat. Do not block the air flow by filling these gaps with any material.

The shiny shield surface facing the heat source must be left unpainted, enabling it to reflect heat back towards the stove or connector and away from the wall.

Clearances may be reduced only by means approved by the regulatory authority, and in accordance with the clearances listed in this manual.

Because of their restricted air flow and heat retention characteristics, specific construction requirements and special clearances apply to installations into alcoves. Refer to the diagrams on Page 10, and contact your Vermont Castings Dealer for details before beginning an alcove installation.

NOTE: ALCOVE INSTALLATION OF THE ENCORE IS NOT PERMITTED IN CANADA.

Wall Shields

One way to reduce clearances is with a wall shield constructed of 24 gauge or heavier sheet metal, or of another noncombustible material such as 1/2" (13 mm) insulation board or common brick "laid on flat," with the 3 1/2" (90mm) side down.

Shields must be spaced out from the combustible surface 1" (25 mm) on noncombustible spacers, as in Figure 14. The spacers should not be directly behind the stove or chimney connector.

Air must be able to flow between the wall and the shield. At least 50% of the bottom 1" (25 mm) of the shield should be open and the shield must be open at the top. Use metal screening, as in Figure 14, to keep stray objects from falling behind the shield.

The shield for a top-exit stove must extend 10" (254 mm) above the top of the stove; for a rear exit configuration, the shield must be 36" (914 mm) high. The shield for the chimney connector must be 30" (762 mm) wide, centered behind the pipe; for installations that use an approved prefabricated chimney to pass through the ceiling, the chimney connector shield must stop 1" (25 mm) below the ceiling.

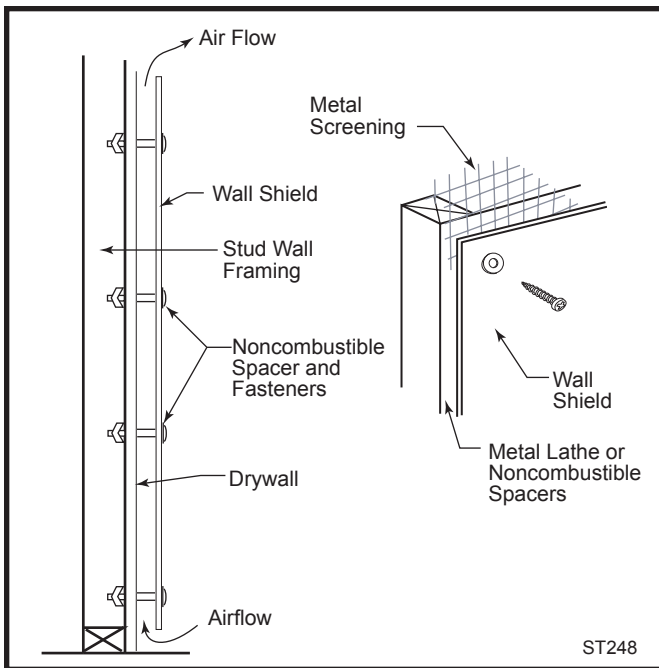

Fig. 14 Approved wall shield construction.

Chimney Connector Heat Shields

Chimney Connector Heat Shields should be used when it is necessary to protect nearby combustibles from the heat of the connector. The ceiling above horizontal runs of chimney connector must be protected as well if the clearance is inadequate.

In top-exiting installations, the connector shield must extend to a point exactly 36" (914 mm) above the flue collar or to an elbow in the connector, whichever is less. If the top-exiting connector extends to the ceiling where it connects with a prefabricated insulated metal chimney, an additional ceiling heat shield must be installed that is 24" (610 mm) in diameter and that extends 1" (25 mm) below the ceiling. The ceiling shield must be constructed of 24 gauge or heavier sheet metal, and must be centered on the chimney.

Fireplace Mantel and Trim Shields

A fireplace installation requires special clearance between the side of the stove and the right and left walls, between the side of the stove and the decorative side trim on the fireplace face, and between the top of the stove and the mantel.

Noncombustible shields installed 1" (25 mm) from the combustible surface on noncombustible spacers, called ventilated shields, may be used to reduce clearances.

To protect a mantel from the heat of an Encore in a fireplace installation, use a custom-made ventilated mantel shield that is at least 48" (1219 mm) long, that is centered over the stove. (Fig. 15) Ventilated shields for side trim must extend the full length of the trim.

An unprotected mantel ("A", Fig. 16) cannot be more than 9" (229 mm) deep and must have a minimum clearance of 38" (965 mm), measured from the stove's top plate. With a ventilated shield, this clearance may be reduced safely to 22" (559 mm).

Unprotected top trim (B) protruding 3/4" (19 mm) or less from the face of the fireplace must be a minimum of 27" (686 mm) from the stove's top surface. With a ventilated trim shield, this clearance may be reduced safely to 20" (508 mm).

Unprotected side trim (C) that protrudes 3/4" (19 mm) or less from the face of a fireplace must have a minimum clearance of 10" (254 mm), measured from the stove's top side edge. If the trim extends more than 3/4" (19 mm), it is subject to the requirements for wall clearance.

The charts and sample installations that follow list all the clearances required for the various installation configurations of the Encore.

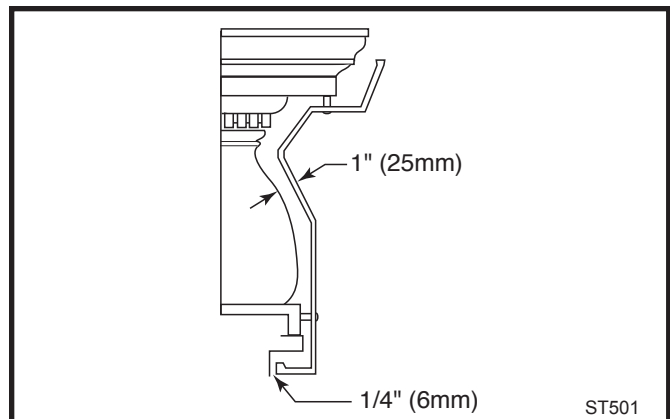

Fig. 15 A custom formed mantel shield.

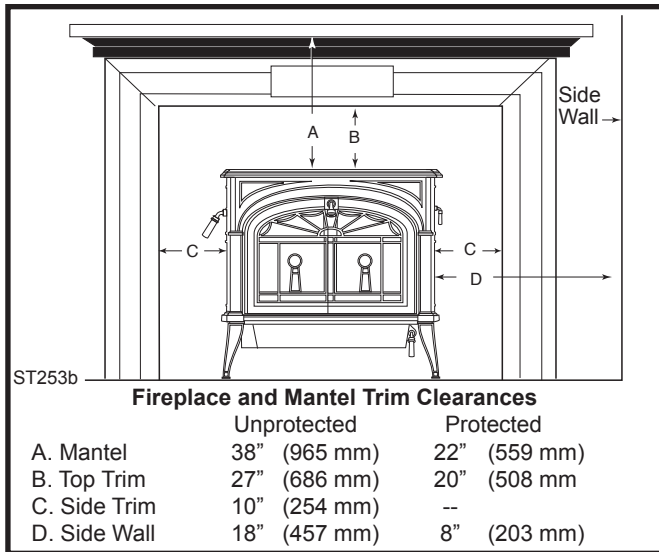

Fig. 16 Maintain clearances to combustible components of the mantelpiece.

Alcove Installations

Because of their restricted air flow and heat retention characteristics, alcove installations have specific construction requirements and special clearances. No rear stove or chimney connector heat shields are used in alcove installations. Bottom heat shield requirements remain the same as for other installations.

ALCOVE INSTALLATION OF THE ENCORE IS NOT PERMITTED IN CANADA.

Construction Requirements

The following illustrations show noncombustible ceiling framing and maximum and minimum permitted dimensions for alcove construction.

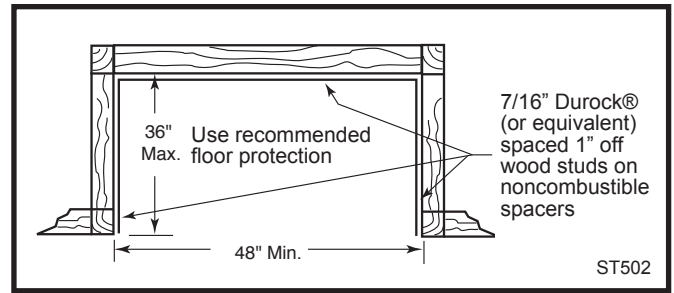

Fig. 17 Floor plan. Sheetrock on front face butts to Durock® (or equivalent) alcove lining.

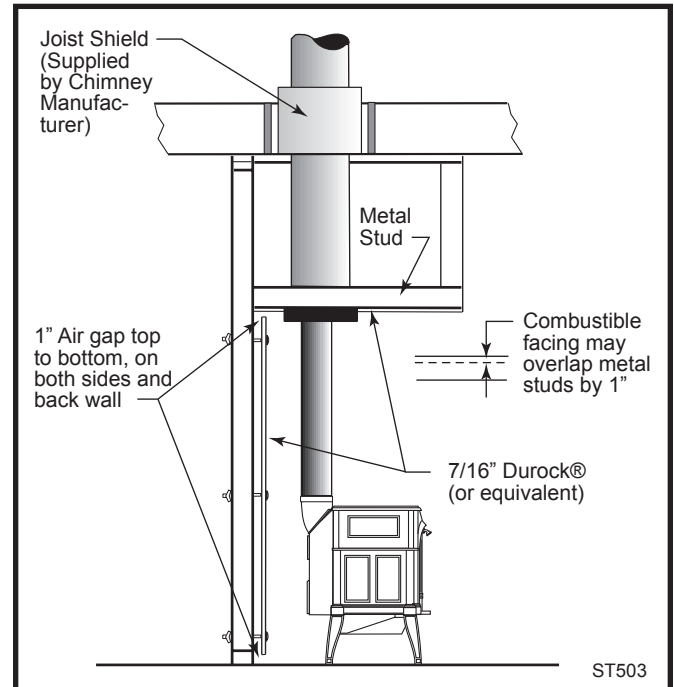

Fig. 18 Alcove side section.

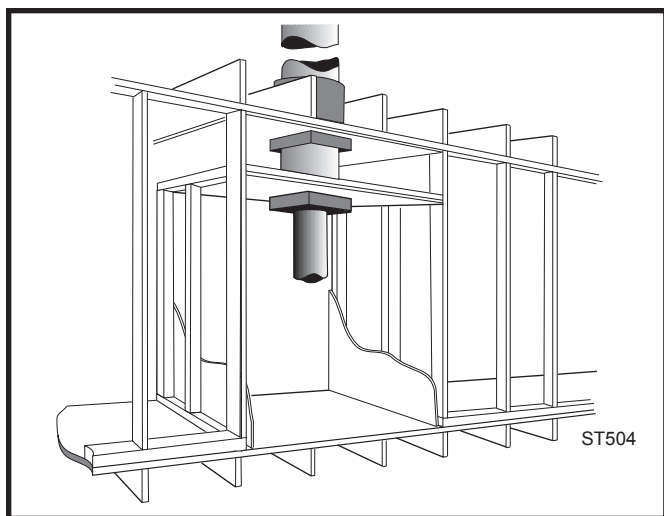

Fig. 19 Cutaway perspective of alcove installation.

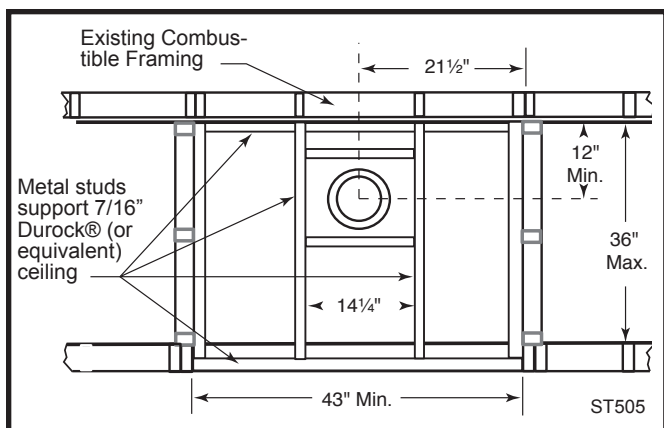

Fig. 20 Reflected ceiling plan.

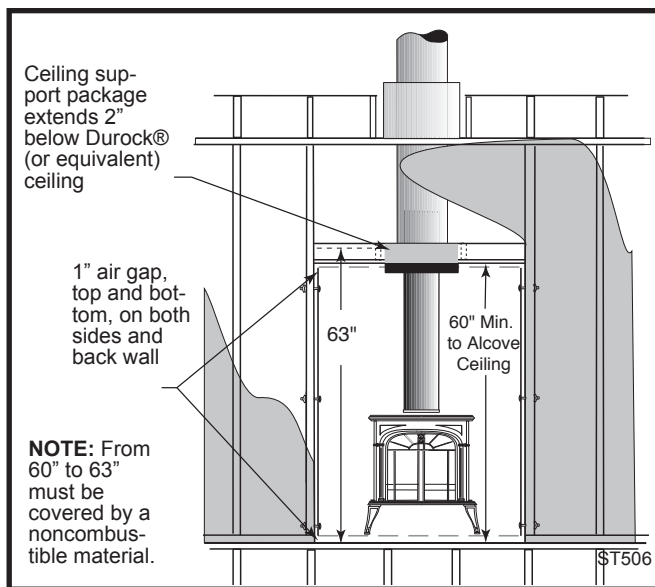

Fig. 21 Front Section; 63" min. clearance from finished floor surface to combustibles on front face. Combustible facing may overlap metal studs by only 1". It should not extend below the height of the noncombustible ceiling.

Encore NC Clearance Chart

For use with either 6" or 8" flue collar/chimney connection

	Unprotected Surfaces			Protected Surfaces		
	Stove Clearance					
	Stove Installed Parallel to Wall		Stove in Corner	Stove Installed Parallel to Wall		Stove in Corner
	Side	Rear	Corners	Side	Rear	Corners
Top Exit, single wall connector without shields, vertical flue collar heat shield installed (except where noted)	(A) 17" (432 mm)	(B) 29" (737 mm)	(C) 28" (711 mm)	(D) 8" ^{1,4} (203 mm)	(E) 15" ^{1,4} (380 mm)	(F) 8" ^{1,4} (203 mm)
Top Exit , single-wall chimney connector heat shields ² , vertical flue collar h.s. installed	(G) 17" (432 mm)	(H) 17" (432 mm)	(I) 19" (483 mm)	(J) 8" ¹ (203 mm)	(K) 11" ¹ (280 mm)	(L) 7" ¹ (178 mm)
Rear Exit	(M) 18" (457 mm)	(N) 24" ⁵ (610 mm)	N/A	(P) 8" (203 mm)	(Q) 6" Collar 11" (279 mm) 8" Collar 19" (483 mm)	N/A
Top Exit , double-wall chimney connector, vertical flue collar heat shield installed	(G) 18" (457 mm)	(H) 6" Collar 23" (584 mm) 8" Collar 17" (432 mm)	(I) 19" (483 mm)	*		
Chimney Connector Clearance						
Single-wall connector, No chimney connector heat shields	21" (533 mm)			7" (178 mm)		
Single-wall connector, Chimney connector heat shields installed	9" (229 mm)			3" (76 mm) ³		
Double-wall connector	6" Connector 15" (381 mm)	8" Connector 9" (229 mm)		*		
Clearance to Combustibles in Front of Stove						
All Installations (S) 48" (1219 mm)						

* Clearances with double-wall connectors and protected surfaces have not been tested for the Encore NC.

1. A ceiling heat shield, 24" (610 mm) in diameter and suspended 1" (25 mm) from the ceiling, must surround the chimney connector in installations in which the chimney connector penetrates the ceiling.
2. The chimney connector shield extends only to 36" (914 mm) above the flue collar.
3. The ceiling heat shield required when the chimney connector shields are used should meet the wall protector. This will require trimming the ceiling shield along the line of intersection with the wall protector.
4. The vertical collar heat shield is not required when wall protection is installed according to this manual.
5. All rear exit installations require a wall shield when combustible material is within 12" (305 mm) of the center of the rear wall pass through. The shield must be 24" (610 mm) in diameter, be spaced 1" (25 mm) from the wall and must surround the chimney connector.

Encore Clearance Diagrams

For use with either 6" or 8" flue collar/chimney connector

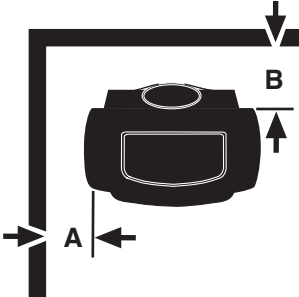
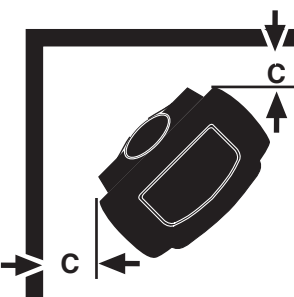
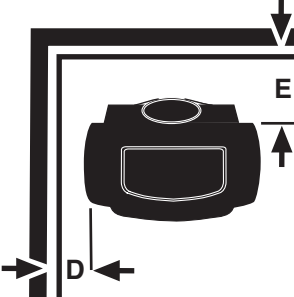
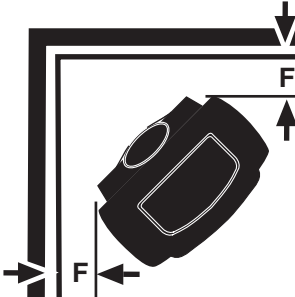
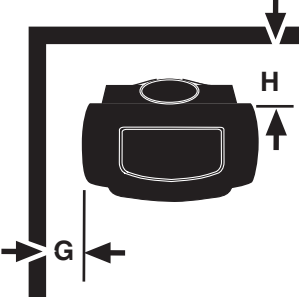
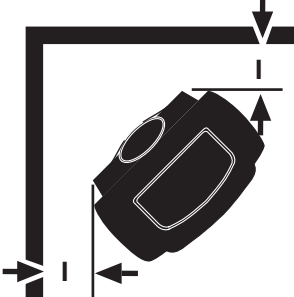
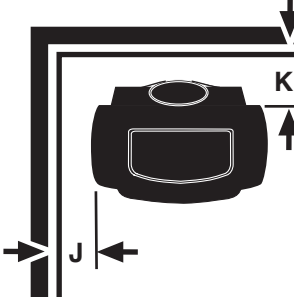
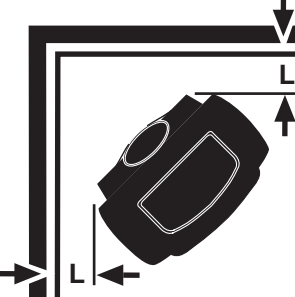
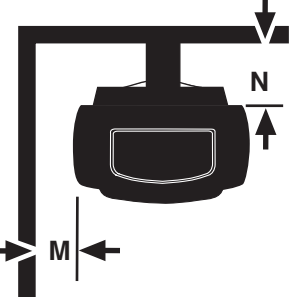
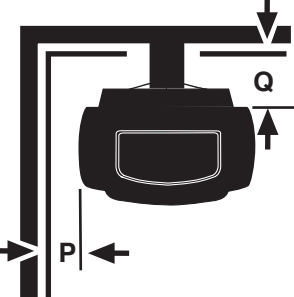
Unprotected Surfaces		Protected Surfaces	
Stove Installed Parallel to Wall	Stove in Corner	Stove Installed Parallel to Wall	Stove in Corner
<p>Top Exit Installations, No Stove Heat Shields, collar heat shield installed.</p>			
			
<p>Top Exit Installations, vertical collar heat shield, and chimney connector heat shields or double-wall connector.</p>			
			
<p>Rear Exit Installations.</p>			
	<p style="text-align: center;">N/A</p>		<p style="text-align: center;">N/A</p>

Wall Shield Requirements for Common Installations

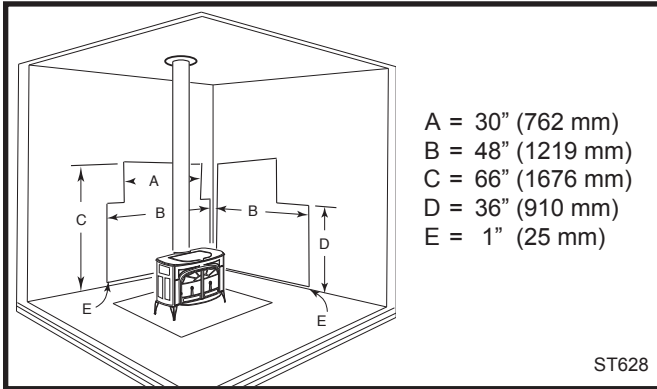

Fig. 22 Parallel installation, vertical chimney connector, two wall shields. Reduced clearances for both rear and side walls. Wall shields may meet at corner if desired. Shielding for connector is centered behind connector.

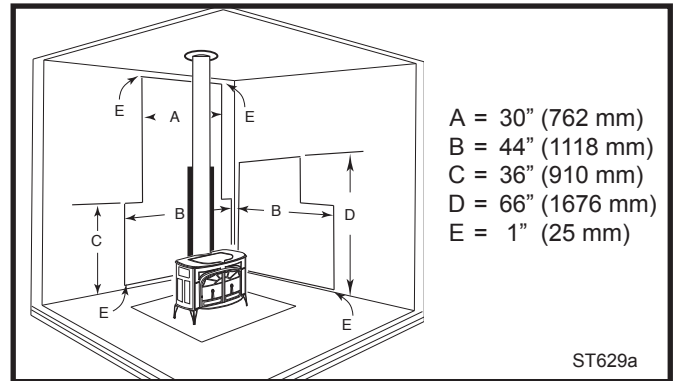

Fig. 23 Parallel installation, vertical chimney connector, with stove, connector and wall shields. Maximum reduction for both rear and side wall. Wall shields may meet at corner if desired. A heat shield 24" (610mm) in diameter suspended 1" (25mm) below the ceiling must surround the chimney.

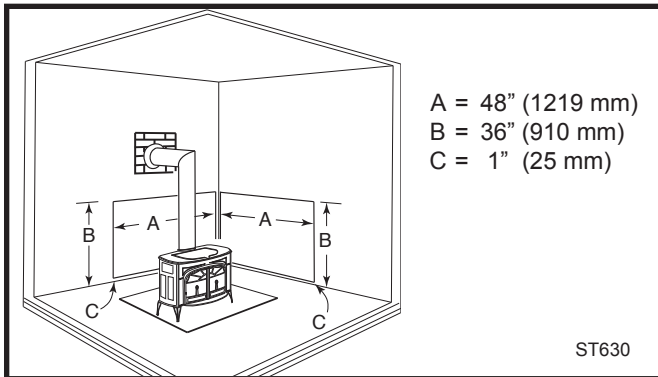

Fig. 24 Parallel installation with rear wall pass-through, two wall shields. Reduced clearances to both rear and side walls. Wall shields may meet at corner if desired. Shielding for connector is centered behind connector. Wall pass-through must comply with codes. (See "Special Installations")

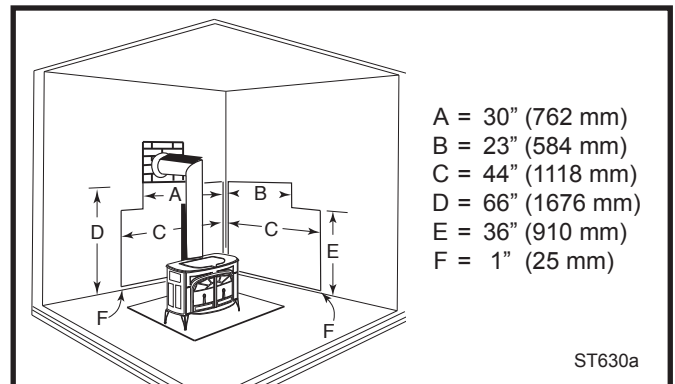

Fig. 25 Parallel installation with rear wall pass-through with stove, connector and wall shields. Wall shields may meet at corner if desired. Connector shield extends 36" (914 mm) above flue collar, or to the elbow whichever is less. Height "D" must be 66" (1676mm) or reach the thimble. Pass-through must comply with codes. (See "Special Installations".)

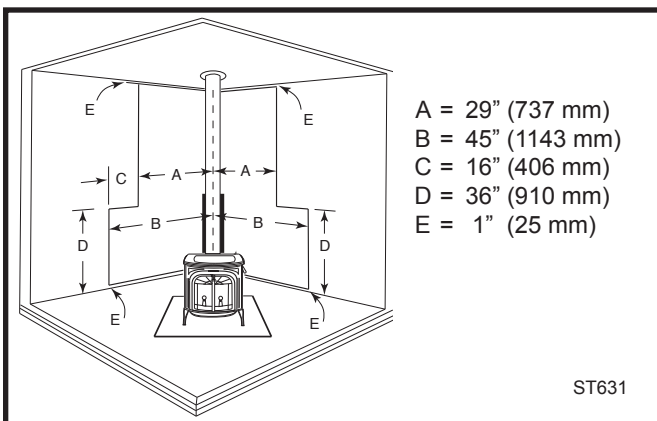

Fig. 26 Corner installation, vertical chimney connector, with rear, stove, connector and wall shields. Wall shields MUST meet at corner. Connector heat shield extends 36" (914 mm) above flue collar. A 24" (610 mm) diameter ceiling heat shield must surround the chimney and be suspended 1" (25 mm) from ceiling.

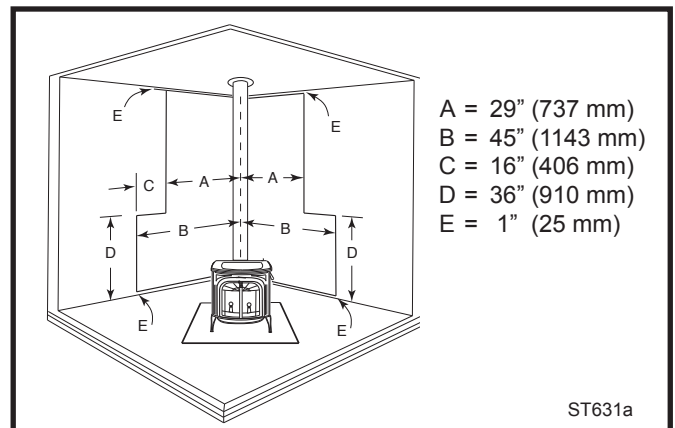

Fig. 27 Corner installation, vertical chimney connector, two wall shields. Reduced side clearances. Wall shields MUST meet at corner. A 24" (610 mm) diameter ceiling heat shield must surround the chimney and be suspended 1" (25 mm) from ceiling.

Distance from the Center of the Flue Collar to the Wall in Top-Exit Installations

The information on this page is helpful in planning stove placement for top-exiting installations, particularly those installations with chimneys that pass through the ceiling. However, this is not a clearance chart. Final stove clearances must adhere to the guidelines stated in the clearance chart on Page 15.

Dimensions indicated are valid for installations with either 6" or 8" flue collars.

Encore: WITHOUT Chimney Connector Heat Shields					
Unprotected Surfaces			Protected Surfaces		
Parallel Installations		Corner Installations**	Parallel Installations		Corner Installations**
Side (a)	Rear (B)	Side (A)	Side (D)	Rear (E)	Corner (F)
30½" (775 mm)	25¼" (641 mm)	34½" (876 mm)	21½" (546 mm)	11¼" (286 mm)	14½" (368 mm)

* This distance, from the center of the flue collar to the front edge of the hearth, is the same for all installations on this page: 35¼" in the United States and 37¼" (946 mm) in Canada.

Encore: WITH Chimney Connector Heat Shields					
Unprotected Surfaces			Protected Surfaces		
Parallel Installations		Corner Installations**	Parallel Installations		Corner Installations**
Side (A)	Rear (B)	Corner (C)	Side (D)	Rear (E)	Corner (F)
30½" (775 mm)	13¼" (337 mm)	25½" (648 mm)	21½" (546 mm)	7¼" (184 mm)	13½" (343 mm)

**To locate center of flue collar for corner installation, add 6½" (165 mm) to the clearance distance from stove corner to wall. Mark off the resulting distance from the corner along both walls. Next, measure the same distance from these two points out from the walls. These last two measurements will meet at a point representing the center of the flue collar. Refer to the diagrams above.

Assembly

Set Up Your Stove

Cast iron stoves are heavy, and it will take two to four people to move your Encore into position.

Wipe the protective coating of oil from the griddle with a clean dry rag or a paper towel.

Install the handle on the griddle. First, place the griddle upside down at the edge of a flat surface and assemble the handle as shown.

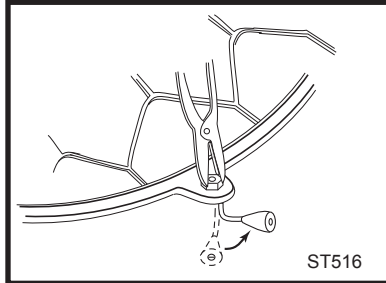

Fig. 28 Attach the griddle handle.

With the handle pointing 45° from its final position, tighten the nut as far as possible with the pliers. Move the handle to its final position while still holding the nut with the pliers.

Install the Bottom Heat Shield

NOTE: The Bottom Heat Shield is required in most installations. Refer to Floor Protection, Page 9, for further details.

1. Remove the four 10-24 x 1/2" hex head bolts from the corners of the ash drop on the stove bottom.
2. Align the bottom heat shield against the spacers with the outside air knockout hole toward the rear of the stove.
3. Secure the shield with the four (4) hex head bolts removed from the stove bottom previously.
4. Tighten securely.

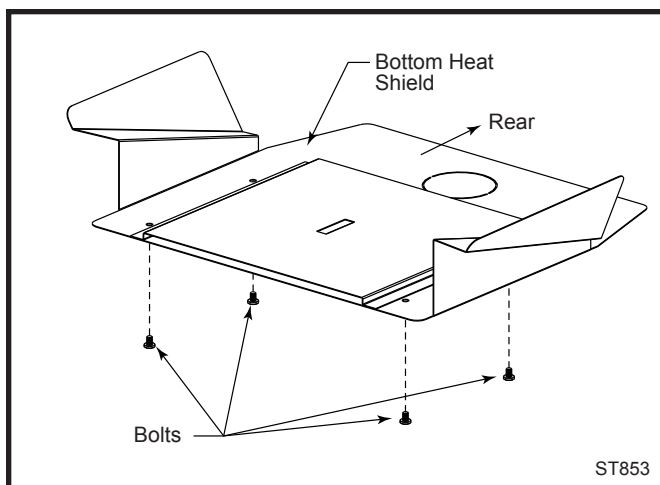

Fig. 29 Use four (4) bolts to attach the bottom heat shield.

Adjust the Leg Levellers

Lift the stove slightly so there is no weight on the leg while making the adjustment.

Reverse the Flue Collar (If Necessary)

Reverse the flue collar by removing the two (2) screws that attach it to the back of the stove. Be sure the gasket around the flue collar opening is in position when you screw the collar back onto the stove.

Attach the Primary Air Thermostat Handle

The primary air thermostat handle is the smaller of the two black handles. Secure the handle to the stub on the right side of the stove with an 8-32 x 2" slot head machine screw.

Attach the Damper Handle

Use the 1/4" -20 x 3" screw to attach the damper handle to the damper stub on the left side.

Assemble the Removable Insert Handle

The white removable insert handle opens and closes the front doors. Remove after each use so it won't get hot. Store it in the handle holder installed behind the right front leg. Assemble the handle by passing the 3/8" screw through the ceramic shaft and into the bright metal nub. Tighten carefully until snug.

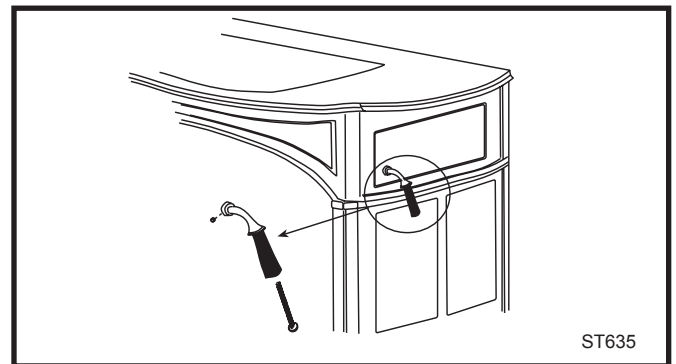

Fig. 30 Attach thermostat handle.

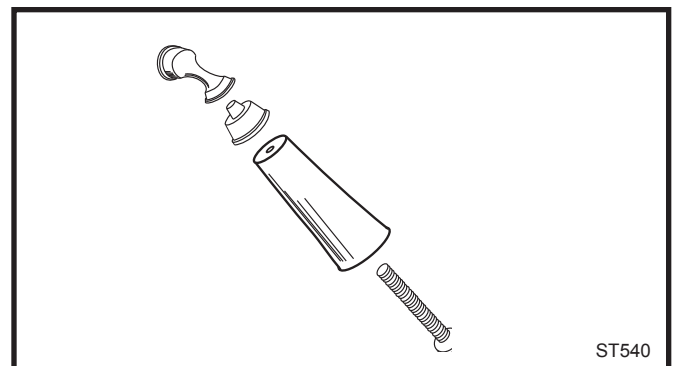

Fig. 31 Assemble the front door handle.

Fan Kit Installation

1. Remove the sheet metal outer back shown in Figure 32.
2. Attach the fan assembly at the bottom edge of the inner back with two (2) 1/4-20 x 3/4" hex head screws and one (1) 1/4" star washer.
3. Attach snapstat to the mounting holes on the underside of the bottom with two (2) 1/4-20 pan head screws.
4. Attach the rheostat holder, (provided with stove), under the right wing of the bottom heat shield with two (2) #10 sheet metal screws.
5. Attach the rheostat to its holder by inserting the rheostat control shaft through the holder hole. Install the retaining ring and rheostat onto the shaft.
6. Secure the rheostat cable to the underside of the bottom heat shield using the wire tie provided on the hole at the right rear edge of the heat shield.
7. Fan will not operate until stove reaches approximately 109°F.
8. Replace the sheet metal outer back.

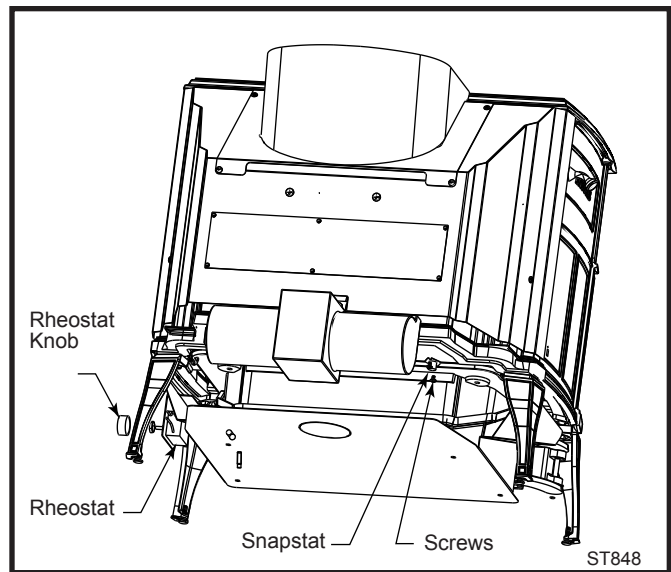

Fig. 32 Fan installation (Kit # 2767).

Operation

The Encore NC Controls

Two controls regulate the performance of the Encore NC: a **primary air control** supplies oxygen for the fire, and a **damper** directs air flow within the stove to activate and deactivate the non-catalytic combustion system. Except when starting or reviving a fire, adding fuel or when the stove doors are open, the damper should always be closed. Operation for extended periods with the bypass open could result in overfiring of the stove causing a possible safety hazard and damage to the stove.

Symbols cast into the stove indicate the correct directions for opening and closing the controls. The symbols assume that you are facing the front of the stove.

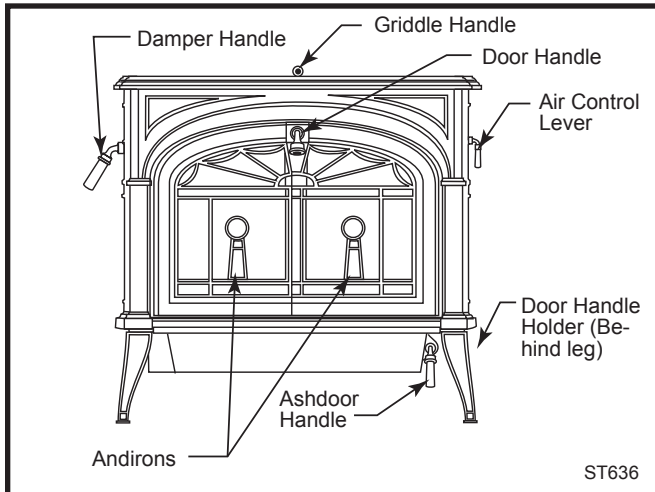

Fig. 33 The Encore controls are conveniently located and easy to operate.

A Single Air Control Regulates Heat Output and Burn Time

The **primary air control lever**, located on the right side of the stove, controls the amount of incoming air for starting, maintaining, and reviving a fire.

More air entering the stove makes the fire burn hotter and faster, while less air prolongs the burn at a lower heat level. High and low settings appear in Figure 34.

For the greatest air supply and maximum heat output (but the shortest burn time), move the lever toward the front of the stove. For a fire that will last longer with less heat, move the lever toward the rear of the stove.

A Damper Directs Air Flow Within the Stove

The **damper handle** on the left side of the stove opens and closes the damper to direct air flow within the stove.

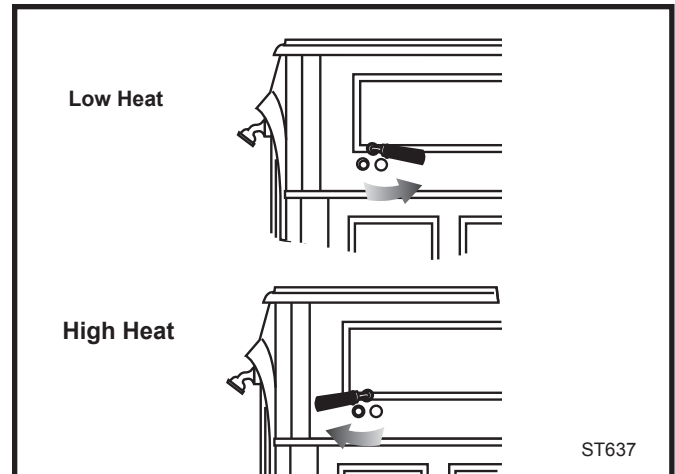

Fig. 34 The handle may be positioned anywhere between the two extremes for different heat levels.

The damper is **open** when the handle points to the back of the stove, enabling smoke to pass directly into the chimney. The damper must be open when starting or reviving a fire, and before and whenever the griddle or doors are opened.

The damper is **closed** when the handle points **forward**. Smoke from the fire is directed through the secondary combustion system where it can be further burned for greater efficiency, before passing up the chimney.

When closing the damper, be sure to pull firmly enough to snap it into the locked position.

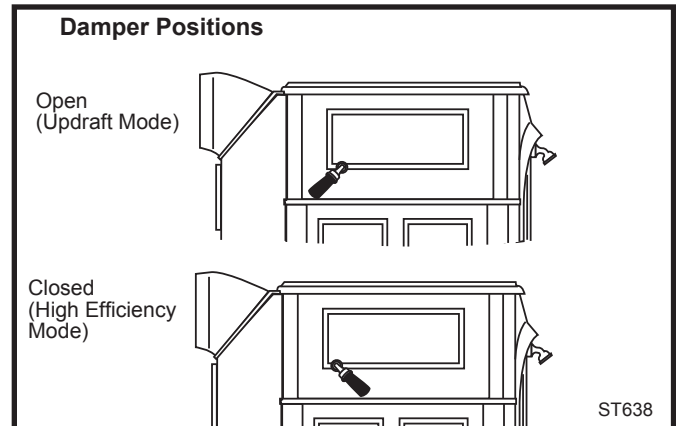

Fig. 35 The damper is either open or closed. There are no intermediate positions.

Two Ways to Add Fuel

The Encore's griddle lifts for convenient top-loading of logs, and is the easiest way to regularly add fuel.

However, the front doors open as well for adding an occasional log to a fire. If equipped with the 8" (203 mm) flue collar, the front doors may be opened (or even removed) and the optional Encore spark screen placed in

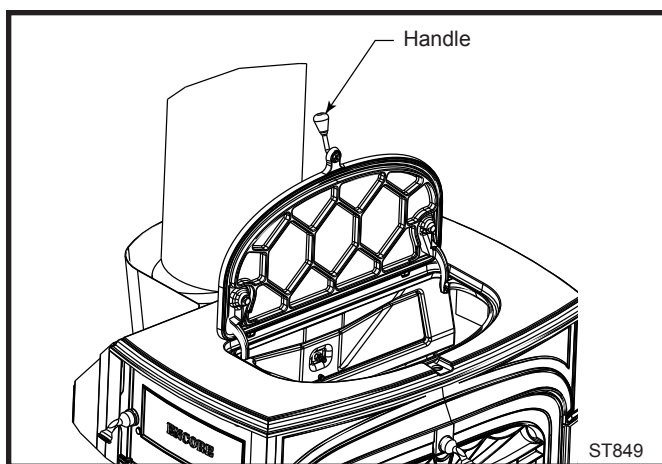

Fig. 36 The Encore's hinged griddle makes it easy to top-load wood.

the opening for open-fire viewing. **The Encore is not approved for operation with the front doors open if equipped with the optional 6" (150 mm) flue collar.**

To open the front doors, insert the handle into the door latch stub and turn it clockwise. (Fig. 37)

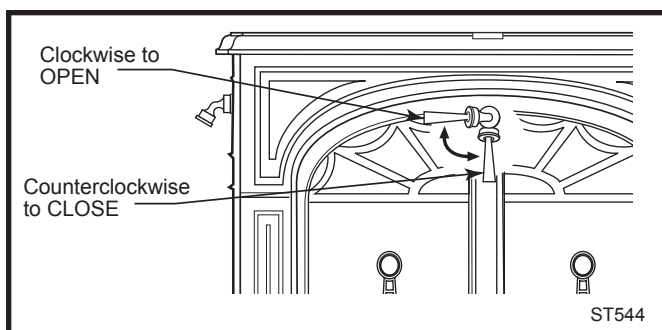

Fig. 37 To open the front doors, turn the handle clockwise.

To close them, always close the left door first. Turn the handle in the right door first clockwise to the open position and swing the door closed. Finally, push on the door as you turn the handle counterclockwise (down). The doors will draw in slightly, and the handle should offer some resistance as you turn it to the closed position.

To reduce the risk of breaking the glass, avoid striking the glass or slamming the doors.

When not using the door handle, store it in the holder behind the right front leg of the stove. (Fig. 33)

WARNING: For safety and greatest efficiency, operate your stove only with all doors/griddles fully closed. The test standard for your stove when it is operated in this mode is UL 1482.

The Encore may be used as a fireplace with the front doors open or removed, **BUT only when it is equipped with an 8" (203 mm) flue collar and only when the optional spark screen is placed correctly in the opening to protect against the possibility of sparks and embers leaving your stove.** The test standard for your stove when it is operated in this mode is UL 737.

Use only the Encore spark screen, item #0127, with your Encore. Encore spark screens are available from your Vermont Castings' Dealer.

Infrared Reflective Glass Panels for Clear Fire Viewing

The inner surfaces of the **infrared reflective glass** panels are kept at a higher temperature than the outer surface. This design, along with a preheated 'airwash,' makes clear fire viewing possible at most levels of operation.

Andirons Help Protect the Glass

Your stove has andirons to keep logs away from the glass panels. The andirons are essential to maintain clear fire viewing, and should be left permanently in place. Since the andirons may slightly hinder refueling through the front doors, many stove owners will prefer the convenience of top loading through the griddle.

Burn Only High-Quality Wood

The Encore is designed to burn natural wood only; do not burn fuels other than that for which it was designed.

You'll enjoy the best results when burning wood that has been adequately air-dried. Avoid burning "green" wood that has not been properly seasoned, or cordwood dried more than two years. **Do not burn construction materials;** they often contain chemicals and metals that are harmful to the stove, chimney system and the environment. The wood should be 18-20" (457-610 mm) in length.

The best hardwood fuels include oak, maple, beech, ash, and hickory that has been split, stacked, and air-dried outside under cover for at least one year.

If hardwood is not available, you can burn softwoods which include tamarack, yellow pine, white pine, Eastern red cedar, fir, and redwood. These too should be properly dried. The basic difference between hard and soft wood is their density. Hardwoods, because of their greater density, burn longer than softwoods and can increase the time between refuelings.

Store wood under cover to keep it dry. The longer it is stored in a dry condition, the better heating and fire viewing performance you will enjoy. Even for short-term storage, however, keep wood a safe distance from the heater and keep it out of the areas around the heater used for refueling and ash removal.

Use the Air Control Settings that Work Best for You

No single air control setting will fit every situation. Each installation will differ depending on the quality of the fuel, the amount of heat desired, how long you wish the fire to burn, climactic conditions; outdoor air temperature and pressure may also effect draft.

The control setting also depends on your particular installation's "draft," or the force that moves air from the stove up through the chimney. Draft is affected by such things as the length, type, and location of the chimney, local geography, nearby obstructions, and other factors. Refer to Pages 25-27 for details on how the installation affects performance.

Too much draft may cause excessive temperatures in the Encore, and could even damage the stove. On the other hand, too little draft can cause backpuffing into the room and/or the "plugging" of the chimney.

How do you know if your draft is excessively high or low? Symptoms of too much draft include an uncontrollable burn or a glowing-red stove part. A sign of inadequate draft is smoke leaking into the room through the stove or chimney connector joints, low heat output and dirty glass.

In some newer homes that are well-insulated and weather-tight, poor draft may result from insufficient air in the house. In such instances, an open window near the stove on the windward side of the house will help provide the fresh air needed.

Another option for getting more combustion air to the stove is to duct air directly from outdoors to the stove. In some areas provisions for outside combustion air are required in all new construction.

Your Encore is equipped to deliver outside air for combustion.

When first using the stove, keep track of the air control settings. You will quickly find that a specific setting will give you a fixed amount of heat. It may take a week or two to determine the amount of heat and the length of burn you should expect from various settings.

Most installations do not require a large amount of combustion air, especially if adequate draft is available. **Do not attempt to increase the firing of your heater by altering the air control adjustment range outlined in these directions.**

Use the following air control settings as a starting point to help determine the best settings for your installation. Each is described as a fraction of the total distance the lever may be moved from right to left.

Encore Control Settings	
Burn Rate	Primary Air Control
Low	From far right to 1/3 the distance to left
Medium	From 1/3 to 2/3 the distance to left
High	From 2/3 the distance to left to far left

DO NOT OPERATE THE STOVE WITH THE ASH DOOR OPEN. OPERATION WITH THE ASH DOOR OPEN CAN CAUSE AN OVERFIRING CONDITION TO OCCUR. OVERFIRING THE STOVE IS DANGEROUS AND CAN RESULT IN PROPERTY DAMAGE, INJURY OR LOSS OF LIFE.

Conditioning Your Stove

Cast iron is extremely strong, but it can be broken with a sharp blow from a hammer or from the thermal shock of rapid and extreme temperature change.

The cast plates expand and contract with changes in temperature. When you first begin using your Encore, minimize thermal stress by allowing the plates to adjust gradually during three or four initial break-in fires.

Starting and Maintaining a Wood Fire

Burn only solid wood in the Encore, and burn it directly on the grate. Do not elevate the fuel. Do not burn coal or other fuels.

The bypass damper must be open when starting a fire or when refueling.

Do not use chemicals or fluids to start the fire. Do not burn garbage. Never use flammable fluids such as gasoline, gasoline type lantern fuel, kerosene, charcoal lighter fluid, naptha, engine oil or similar liquids to start or "freshen up" a fire in this heater. Keep all such liquids well away from the heater while it is in use.

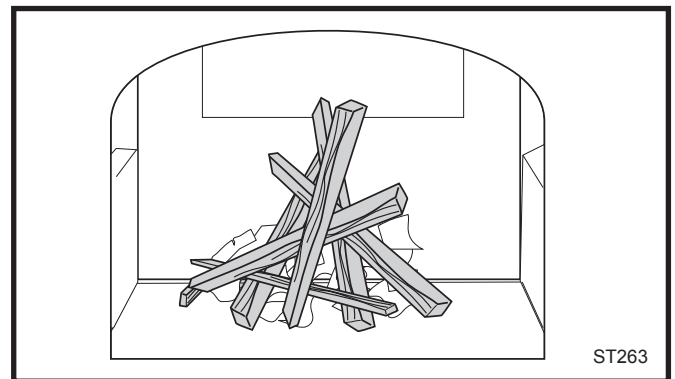

Fig. 38 Start fire with newspaper and dry kindling.

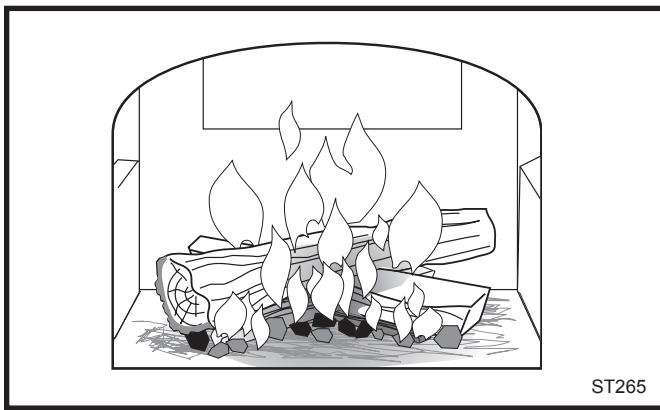

Fig. 39 Add larger pieces of wood as the fire begins to burn well.

During the break-in fires, do not let the stove get hotter than 500°F (260°C) as measured on an optional stove-top thermometer. Adjust the air control lever as necessary to control the fire.

Some odor from the stove's hot metal, the paint, and the cement is normal for the first few fires.

NOTE: Some chimneys need to be "primed," or warmed up, before they will draw sufficiently to start a fire. To correct this situation, roll up a couple pieces of newspaper, place them on top of the kindling and toward the back of the stove, light them, and close the doors. This will encourage smoke to rise rapidly, encouraging a good draft.

Once the draft is established, open the front door and light the rest of the fuel from the bottom. Do not light the main bed of fuel until the chimney begins drawing, and repeat the procedure as often as necessary if the initial attempt is unsuccessful.

If your Encore has been broken-in previously using, continue to build the fire gradually. Add larger wood with a diameter of 3-4" (76-102 mm). Continue adding split logs of this size to the briskly-burning fire until there is a glowing ember bed at least 3" (76 mm) deep. A good ember bed is necessary for proper functioning of the combustion system and may take an hour or more to establish.

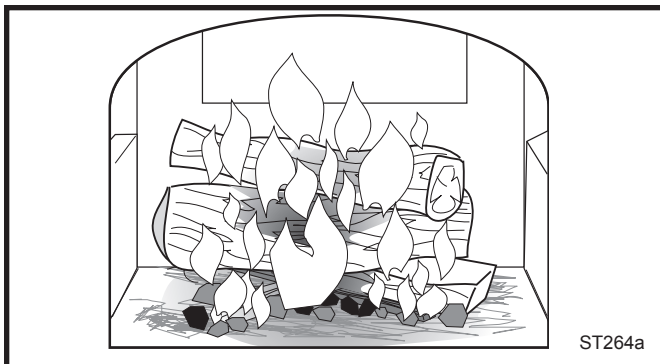

Fig. 40 Add full-size logs when the kindling has burned down to a bed of embers.

Refuel While the Embers Are Still Hot

When reloading, best results will be achieved if you first de-ash the stove by stirring the fuel bed to allow ash to fall through the grate into the ash pan.

Do not break the charcoal into very small pieces or pound or compress the charcoal bed.

It is important that air can circulate through the charcoal bed while the heater is in operation. Larger pieces of charcoal allow more air to circulate under the wood, resulting in the fire reviving more quickly.

For best results when refueling, wear stove gloves to protect your hands, add fuel while the stove still has plenty of glowing embers to re-kindle the fire, and include some smaller pieces of wood in the new fuel load to help the stove regain its operating temperature quickly. Use this sequence as a guide to successful refueling:

1. Open the damper.
2. De-ash the stove as described above. Open the front doors and check the level of ash in the ash pan. Empty the pan if necessary and replace it in the stove. Close the front doors.
3. Open the griddle, load the wood (smaller pieces first), and close the griddle.
4. Allow the stove to regain its "thermal momentum" before closing the damper. This may take 15--20 minutes.
5. Close the damper and set the air control lever for the desired heat output. When the surface temperature reaches 450°F (230°C), adjust the air control for the amount of heat you desire.

NOTE: If the charcoal bed is relatively thick {about 2"-3" (52-76 mm)} deep, and if your fuel is well seasoned, it is possible to add fresh fuel (smaller pieces first), close the door and damper, and reset the primary air control for the desired heat output within five minutes.

WARNING: FIREPLACE STOVES EQUIPPED WITH DOORS SHOULD BE OPERATED ONLY WITH DOORS FULLY OPEN OR DOORS FULLY CLOSED. IF DOORS ARE LEFT PARTLY OPEN, GAS AND FLAME MAY BE DRAWN OUT OF THE FIREPLACE STOVE OPENING CREATING RISKS FROM BOTH FIRE AND SMOKE.

CAUTION: The Encore will be hot while in operation. Keep children, clothing and furniture away. Contact may cause skin burns.

DO NOT OVERFIRE THIS HEATER. Overfiring may cause a house fire, or can result in permanent damage to the stove. If any part of the Encore glows, you are overfiring.

Ash Removal and Disposal

You should remove ash before it reaches the top of the ash pan. Check the level at least once a day. Every few days, clear any ash from the outer edges of the firebox and the cavity areas of the stove. Most of the ash will fall through the grate. Slice or stir the ash with a shovel or poker so that it falls through the grate slots.

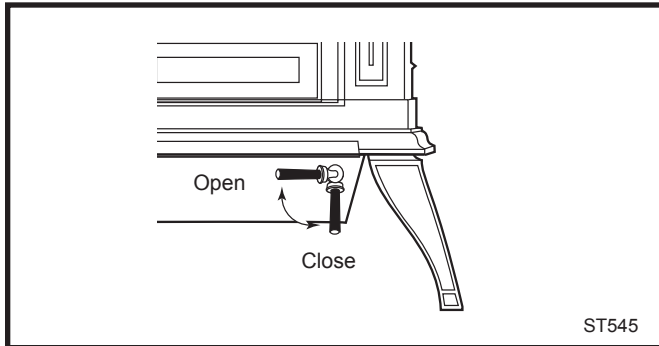

Fig. 41 Turn the handle to the ash pan compartment clockwise to open and counterclockwise to close.

IMPORTANT: Check the level of ash in the ash pan before reloading the stove. If the ash level is close to the top edge of the pan, empty the pan according to this procedure:

- Open the damper.
- Open the griddle or front doors, and use a shovel or poker to stir excess ash through the ash slots in the grate down into the ash pan.
- Close the griddle or doors, and unlatch the ash door. It will pivot, swinging the ash pan out of the stove.
- Slide the cover onto the pan, making sure it is securely closed. (Fig. 42)

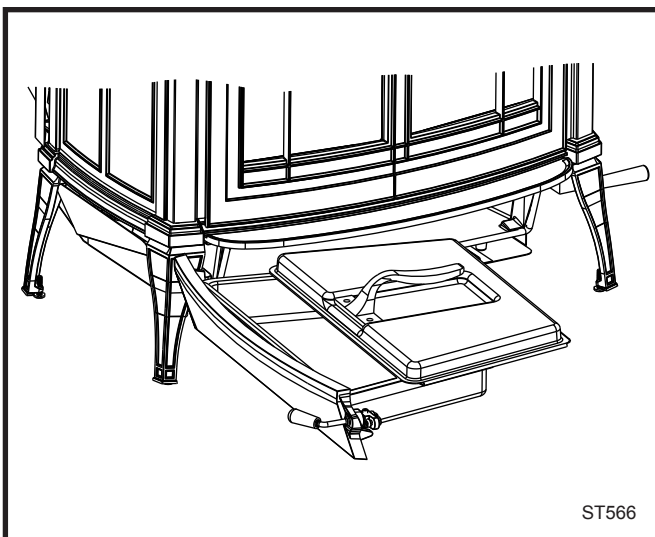

Fig. 42 Be sure the cover is securely attached before removing the ash pan.

- Remove the ash pan, making sure to keep it level.
- To keep the cover from sliding off and to keep ash from falling on the floor, do not tilt the ash pan forward.
 - If the stove is in operation, close the ash door while disposing of the ash.
- Properly dispose of the ash in a metal container with a tight-fitting lid. Store the container outdoors away from all combustible material.
- Return the ash pan to its original position in the stove, and close and latch the ash door.
- Do not operate the stove with the ash door open. This will result in over-firing, and could cause damage to the stove, void the warranty, or even lead to a house fire.

Empty the ash pan regularly, typically every one to three days. The frequency will vary depending on how you operate your Encore: ash will accumulate faster at higher heat outputs.

Remove ash frequently and place it outdoors in a metal container with a tight-fitting lid. Place the closed container of ash on a noncombustible floor or on the ground, well away from all combustible materials, pending final disposal. If the ash is disposed of by burial in soil or otherwise locally dispersed, it should be kept in the closed container until all cinders have thoroughly cooled.

You can use wood ash as a garden fertilizer.

CAUTION: Never use your household or shop vacuum cleaner to remove ash from the stove; always remove and dispose of the ash properly.

Draft Management

A stove is part of a system which includes the chimney, the operator, the fuel and the home. Each part of the system affects how well the stove operates. When there is a good match between all the parts, the system works well.

Wood stove or insert operation depends on natural (unforced) draft. Natural draft occurs when the smoke is hotter (and therefore lighter) than the outdoor air at the top of the chimney. The larger the temperature difference, the stronger the draft. As the smoke rises from the chimney it provides suction or 'draw' that pulls air into the stove for combustion. A slow, lazy fire with the stove's air inlets fully open indicates a weak draft. A brisk fire, supported only by air entering the stove through the normal inlets, indicates a good draft. The stove's air inlets are passive; they regulate how much air can enter the stove, but depend entirely on the draft of the chimney.

Depending on the features of your installation - (i.e. metal or masonry chimney installed, inside or outside the house, matched to the stove's outlet or oversized) - your system may warm up quickly or it may take a while to warm up and operate well. With an 'airtight' stove or insert, one which restricts the amount of air getting into the firebox, the chimney must keep the smoke warm all the way to the outdoors. Some chimneys do this better than others. Here is a list of features and their effects.

Masonry Chimney

Masonry is a traditional material for chimneys, but it can perform poorly when it serves an 'airtight' stove. Masonry is a very effective 'heat sink' - it absorbs a lot of heat. It can cool the smoke enough to diminish draft. The bigger the chimney, the longer it takes to warm up. It's often very difficult to warm up an outdoor masonry chimney, especially an oversized one, and keep it warm enough to maintain an adequate draft.

Metal Chimney

Most factory-made metal chimneys have a layer of insulation around the inner flue. This insulation keeps the smoke warm. The insulation is less dense than masonry, so a steel chimney warms up more quickly than a masonry chimney. Metal doesn't have the good looks of masonry, but it often performs much better.

Indoor / Outdoor location

Because the chimney must keep the smoke warm, it is best to locate it inside the house. The relatively warm house then surrounds the chimney keeping it warm. This also means that heat from the chimney walls will transfer to the house and not be wasted outdoors. An indoor chimney will not lose its heat to the outdoors, so

it takes less heat from the stove to heat it up and keep it warm.

Flue Sizing

The interior size of a chimney for an 'airtight' stove should match the size of the stove's flue outlet. When a chimney serves an airtight stove, "more" is not "better"; in fact, it can be a disadvantage. Exhaust gases move more slowly through larger chimneys and can lose more heat to the chimney walls. This weakens the draft strength. If an oversized flue is also outside the house, the heat it absorbs gets transferred to the outdoor air and the flue is further cooled.

It's common for a masonry flue, especially one serving a fireplace, to be oversized for the stove. It can take quite a while to warm up such a flue, and the results can be disappointing. The best solution to an oversized flue is an insulated steel chimney liner, the same diameter as the stove or insert's flue outlet; the liner keeps the exhaust warm, and the result is a stronger draft. An uninsulated liner is a second choice - the liner keeps the exhaust path restricted to its original size, but the air around the liner must still be heated. This makes the warm-up process take longer.

Pipe & Chimney Layout

Every turn the exhaust must take as it travels to the chimney top will slow it down. The ideal pipe and chimney layout is straight up from the stove, and into a vertical chimney. If you are starting from scratch, use this layout if possible. If the stovepipe must turn to enter a chimney, locate the thimble about midway between the stove top and the ceiling. This achieves several goals: it allows the exhaust gases to speed up before turning, it leaves some pipe in the room for heat transfer, and gives you long-term flexibility to install a future stove without relocating the thimble.

There should be no more than 8 feet (2.4m) of single-wall stove pipe between the stove and a chimney; longer runs can cool the exhaust gases enough to cause draft and creosote problems. Use double-wall stove pipe for long runs.

Single venting

Each 'airtight' stove requires its own chimney. If an airtight stove is vented to a flue that also serves an open fireplace, it is easier for the chimney draft to pull air in through those channels than it is to pull air through the stove, and performance suffers. Imagine a vacuum cleaner with a hole in the hose to see the effect here. In some cases the other appliance can even cause a negative draft through the airtight, and result in a dangerous draft reversal.

Creosote

Creosote is a by-product of slow wood-burning. It is an organic tar that can condense in the flue if the exhaust gases cool too much. Condensed creosote is volatile, and can fuel chimney fires if it gets hot enough. All the factors that affect chimney draft also affect creosote condensation - so use installation features and operational steps that encourage good draft and minimize creosote production.

Because letting the smoke cool off and slow down is one of the keys to creosote production, it makes sense to line a chimney to match the stove's outlet size, for safety reasons as well as performance. Canadian law *requires* a matching liner to serve any stove or insert vented through a fireplace chimney; in the US, the National Fire Protection Association recommends a liner if the chimney is more than three times bigger (in square area) than the outlet on the stove or insert. Some localities enforce the NFPA guidelines as part of their building codes.

Fuel

Even the best stove installation will not perform well with poor fuel. The best fuel is hardwood that has air-dried 12-18 months and is stored, covered from the elements. Softwoods burn well, but not as long as hardwood. 'Green' wood has more moisture in it; it will burn, but more of the heat from the fire is needed to drive the extra moisture off the wood. This reduces the amount of heat that reaches your home and can contribute to a creosote problem. There are moisture meters available for firewood; you can also judge your wood by its appearance and weight. If you get it green, lift a piece and get a sense of its weight; it can lose a third or more of its weight as it dries. Also look at the ends of a log; as it dries it shrinks and often cracks. The more weathered and cracked a piece is, the drier it is.

Back-puffing

"Back-puffing" results when the fire produces volatile gases faster than the chimney draft pulls them out of the firebox. The gases back up in the firebox until they are dense enough and hot enough to ignite. If your stove back-puffs, you should open the damper to direct more heat up the chimney to allow the smoke to rise to the flue more quickly, let more air into the firebox. Smaller loads of wood, larger pieces of wood and avoiding overly dry wood loaded into a very hot stove may help this problem. If back-puffing persists, contact your dealer or qualified chimney sweep to help diagnose the problem.

Draft Testing

An easy way to test your chimney draft is to close the stove's damper, wait a few minutes to let the airflow stabilize, then see whether you can vary the strength of the fire by swinging the air control open and closed. Results are not always instant; you may need to wait a few minutes for a change in the air control setting to have an effect on the fire. If there's no change, then the draft isn't strong enough yet to let you close the damper, and you'll need to open it for a while longer and manage the fire with the air inlet until the draft strengthens. Test chimney draft with a draft gauge.

Negative Pressure

Good draft also depends on a supply of air to the stove; a chimney can't pull in more air than is available to it. Sluggish draft results when a house is tight enough to prevent the ready flow of air to the stove, or by competition between the stove and other equipment that removes air from the house - especially power-driven equipment like range hoods, clothes dryers, etc. If the chimney draws well with all other equipment turned off (or sealed, in the case of fireplaces and/or other stoves), then you simply need to be careful with timing the use of the other equipment. If you need to crack a nearby window or door to enable the chimney to pull well, that's a sign that you should install an outside-air intake to bring combustion air directly to the stove. For most of our stoves, adapters are available to connect an air duct for outdoor combustion air.

Conclusion

Wood-burning is an art rather than a science. Once the stove and chimney system are in place, you can only vary your technique, mostly your timing, to achieve good results. If you keep track of your burning habits and relate them to their effects on the stove's operation, you'll be rewarded with good performance and a safe system.

Maintenance

Keep Your Stove Looking New and Working Its Best

Let the fire in the stove go out and allow the stove to cool completely before beginning any maintenance procedure.

Care of the Cast Iron Surface

An occasional dusting with a dry rag will keep the painted cast iron of your Encore looking new.

The stove's paint can be touched up as needed. First, mask the areas, such as enamelled parts, glass, or handles, around the area to be painted. Clean the area with a wire brush to remove any loose paint or dust. Remove the griddle and set it aside.

Then, touch up the stove with Vermont Castings' high temperature stove paint. Apply the paint sparingly; two light coats of paint are better than a single heavy one.

Care of the Porcelain Enamel Surface

Use a dry or slightly damp rag or soft brush to remove spills or stains. For difficult jobs that require a cleaning agent, use only a kitchen appliance cleaner or polish recommended for use on enamel surfaces.

Cleaning the Glass

Most of the carbon deposits on the glass will burn off during hot fires.

However, the ash residue that accumulates on the glass surface should be removed regularly to prevent etching. To clean the glass, follow this procedure:

- Be sure the glass is completely cool.
- Clean the glass with water or a cleaner made especially for this purpose. Do not use abrasive cleaners.
- Rinse the glass thoroughly.
- Dry the glass completely.

Replace Broken Glass Immediately

Do not operate your stove if the glass in the doors is damaged.

If you need to replace the glass, use only the high temperature ceramic glass supplied by Vermont Castings. Do not use substitutes. Be sure to specify left or right glass; the panels are not interchangeable.

Removing the Glass

1. Remove the right and left door assemblies by raising the door until the lower hinge pin clears its drilling; then, angle the door bottom slightly outward and pull down to release the upper hinge pin. Place the doors face down on a padded work surface.
2. Remove the screws that hold the retainer clips in place, and remove the clips.
3. Carefully lift the broken glass panel from the door.

Installing the Glass

Check the gasket around the window; it should be soft and resilient so the glass will seal properly against the door. Replace the gasket if it has hardened or if it is compressed.

1. Center the first pane of glass on the gasket. Be sure to place the glass so the infrared reflective coating is on the exterior side.

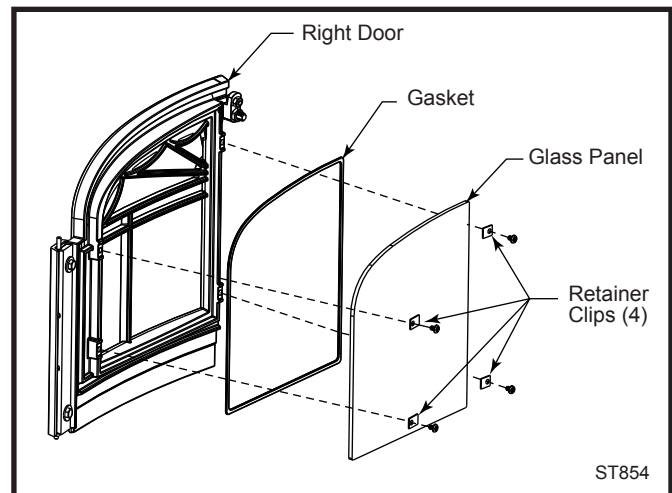

Fig. 43 Exploded view of the glass assembly for the right door.

2. Secure the glass on both doors with the retainer clips, but leave the screws a little loose.
3. Gradually tighten all the screws by hand a little at a time in order to apply even pressure to the glass panel.

Adjust the Damper as Needed

The tension on the Encore's damper is adjustable to compensate for compression of the gasket that seals the damper to the upper fireback. To adjust the damper:

1. Remove the griddle. Loosen the lock nut at the center of the damper.
2. Turn the pressure screw approximately one half turn clockwise.

3. Tighten the lock nut. Keep the pressure screw from turning as you tighten the nut. Re-test the damper.

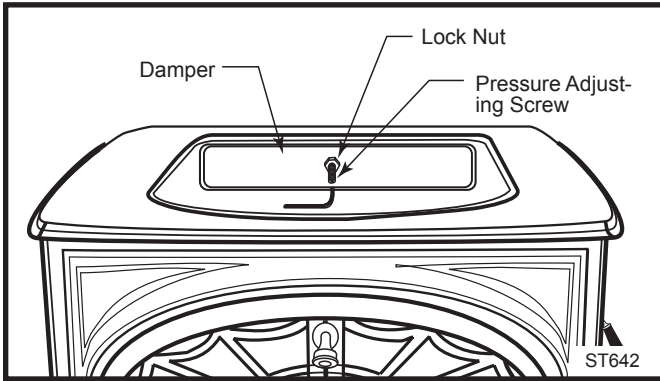

Fig. 44 Adjusting the damper.

Tighten the Damper Handle as Needed

A handle on the left side of the stove controls the damper. The handle attaches to the damper rod with a set screw. Periodically check the set screw and tighten as necessary.

Adjust the Door Latches

The Encore's front doors, as well as its ash pan door, should close securely to prevent accidental opening and to keep air from leaking into the stove. On adequately adjusted doors, the handles should resist slightly as they are turned to the closed position and the doors themselves should be drawn slightly toward the stove.

Over time, the gasket around the doors will compress and the latches may need adjustment.

To adjust the latches on the doors, loosen the small lock nut, rotate the striker screw a half-turn, and re-tighten the small lock. Hold the striker screw to keep it from turning as you tighten the lock nut. Make repeated small adjustments until the setting is right.

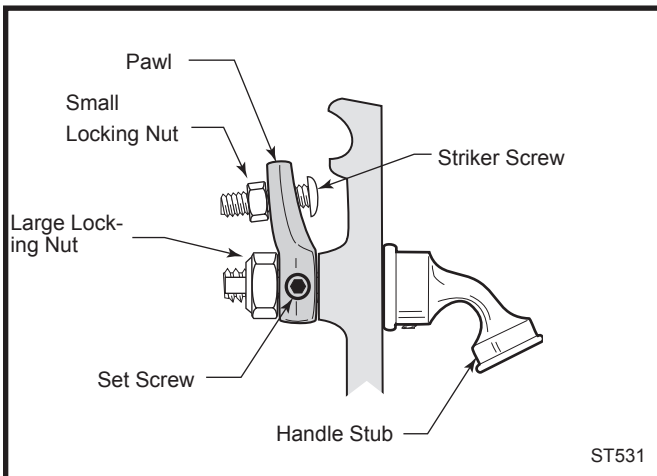

Fig. 45 Turn the door latch striker screw in or out to tighten or loosen the door latch.

Replace the Stove Gaskets as Needed

Your Encore uses rope-type fiberglass gaskets to make a tight seal between some parts. With use, particularly on those parts that move, gaskets can become brittle and compressed and can begin to lose their effectiveness. These will need periodic replacement.

All of the gaskets are made of fiberglass. The sizes of replaceable gasket are listed below, along with their applications.

Gasket Diameter	...And the Parts it Seals
5/16"	The griddle to the stove top (wire reinforced gasket)
3/8"	The ash door to the front of the ash drop, flue collar to inner back
3/16"	The outer glass panes to the doors
5/16"	The damper to the upper fireback; the front doors to the stove front; and the doors to each other.

If you need to change a gasket, first obtain an appropriate replacement from your Vermont Castings' Authorized Dealer.

Wait until the fire is out and the stove has cooled. Be sure to follow the standard safety procedure for working with dusty materials: Wear safety goggles and a dust mask.

The procedure for replacing gaskets is the same regardless of the gasket location. Follow these steps:

1. Remove the existing gasket by grasping an end and pulling firmly.
2. Use a wire brush or the tip of a screwdriver to clean the channel of any remaining cement or bits of gasket. (Fig. 46) Remove stubborn deposits of cement with a cold chisel if necessary.

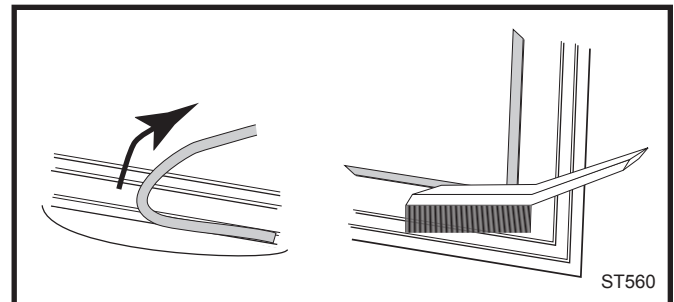

Fig. 46 Remove gasket then clean channel with wire brush.

- Determine the correct length of the appropriate-sized gasket by laying it out in the channel. Allow an extra 1-2" (25-50 mm), and mark the spot to be cut. (Fig. 47)
- Remove the gasket from the channel, place it on a wood cutting surface, and cut it at the marked spot with a utility knife. Twist the ends slightly to keep the gasket from unraveling.
- Lay an unbroken 1/8" (3mm) bead of gasket cement in the newly-cleaned channel.
- Starting at one end, press the gasket into the channel. (Fig. 47) Ensure a good joint where the gasket meets before trimming any excess. Do not overlap the gasket ends or leave ends with ragged edges.

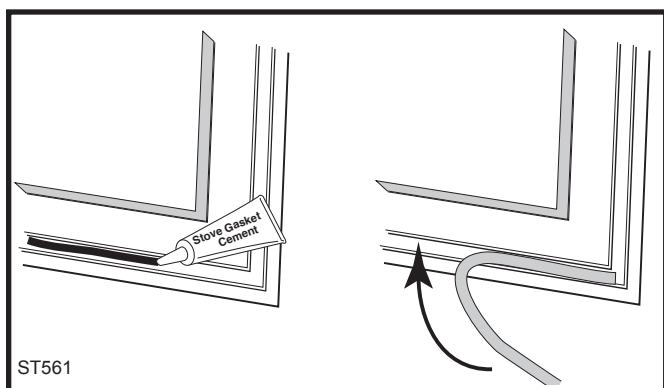

Fig. 47 Lay a bead of gasket cement then press gasket in place.

- Press the gasketed part firmly against its normal mating surface to seat the gasket evenly in its channel. Close and latch the door to do this, or tap other parts with the rubber mallet (or hammer/block of wood).
- Clean any excess cement from around the channel, then let the cement that holds the new gasket dry thoroughly.

Adjust the Door If Necessary

The stove's door(s) may need adjustment after you have regasketed it. Initially, it may require loosening to accommodate the new gasket; after a few weeks, it may need tightening to compensate for compression of the new gasket. The directions for adjusting the doors are on Page 28.

All Gasketed Construction

Other gaskets form seals between non-moving parts, but these are not subject to the same wear and deterioration as gaskets on moving parts. It is unlikely that you will ever need to replace these gaskets unless the involved parts are disassembled and then put back together. If this is the case, the job should be done only by a qualified service technician.

5/16" diameter gasket seals the following parts:

- The flue collar to the stove back
- The lower fireback to the sides
- All connections between the major stove plates

The Chimney System

Creosote

Your Encore is designed to reduce creosote build-up significantly. However, regular chimney inspection and maintenance must still be performed. For safety, good stove performance, and to protect your chimney and chimney connector, inspect your chimney and chimney connector on a regular schedule. Clean the system if necessary. Failure to keep the chimney and connector system clean can result in a serious chimney fire.

When wood is burned slowly, it produces tar, organic vapors and moisture that combine to form creosote. The creosote vapors condense in the relatively cool chimney flue of a slow-burning fire. As a result, creosote residue accumulates on the flue lining. When ignited, this creosote makes an extremely hot fire within the flue system that can damage the chimney and overheat adjacent combustible material. If a significant layer of creosote has accumulated —1/8" (3mm) or more — it should be removed to reduce the risk of a chimney fire.

To reduce the amount of creosote that may form, remember to provide adequate air for combustion and to strive for small, intense fires rather than large, smoldering ones.

You can never be too safe. Contact your local fire authority for information on what to do in the event of a chimney fire, and have a clearly understood plan on how to handle one.

You should inspect the system every two weeks during the heating season as part of a regular maintenance schedule. To inspect the chimney, let the stove cool completely. Then, using a strong light, sight up through the flue collar into the chimney flue. If it is not possible to inspect the flue system in this fashion, the stove must be disconnected to provide better viewing access.

Clean the chimney using a brush the same size and shape as the flue liner. Flexible fiberglass rods are used to run the brush up and down the liner, causing any deposits to fall to the bottom of the chimney where they can be removed through the clean-out door.

Clean the chimney connector by disconnecting the sections, taking them outside, and removing any deposits with a stiff wire brush. Reinstall the connector sections after cleaning, being sure to secure the joints between individual sections with sheet metal screws.

If you cannot inspect or clean the chimney yourself, contact your local Vermont Castings' Dealer or a professional chimney sweep.

Maintenance Schedule

The Stove

DAILY:

- Clear any ash build-up from around the air holes and combustion flow path in the lower fireback.
- Ashes should be removed before they reach the top of the ash pan. Check accumulation at least once a day.
- Keep the area around the stove clear of any combustible materials such as wood, furniture or clothing.

TWO MONTHS:

- Check door handle to be sure it is working properly. Gasketing becomes compressed after a period of time. Adjust handle tightness if necessary.
- Check leg bolts and heat shield screws; tighten if necessary.

ANNUAL SPRING CLEANING:

- Check gasketing for wear, and replace if necessary.
- Remove ashes from the ash pan and replace with a moisture absorbing material (such as kitty litter) to keep the interior of the stove dry.
- Clean the dust from the inner sides of bottom, rear or pipe heat shields if your stove is equipped with them. Clean surfaces are better heat reflectors than dirty surfaces.
- Touch up the black paint.
- Inspect for and remove ash build-up behind the combustion package. This should be done in conjunction with annual cleaning of the chimney connector since this inspection is most conveniently done through the flue collar opening. Inspect the passages to either side of the combustion package (a mirror will be helpful) and vacuum away ash using a flexible vacuum hose inserted into each passage. Care should be taken not to damage the white fibrous material in this rear chamber. (Fig. 48)

The Chimney Connector

TWO WEEKS:

- Inspect the chimney connector and chimney. Clean if necessary.

TWO MONTHS:

- Inspect the chimney and chimney connector. Pay particular attention to the horizontal runs of chimney connector, and the elbows. Clean the system if necessary.

ANNUAL SPRING CLEANING:

- Disassemble the chimney connector and take it outdoors for inspection and cleaning. Replace weak sections of connector.
- Inspect the chimney for signs of deterioration. Repairs to a masonry chimney should be made by a professional mason. Replace damaged sections of prefabricated chimney. Your local Vermont Castings dealer or a chimney sweep can help determine when replacement is necessary.
- Thoroughly clean the chimney.

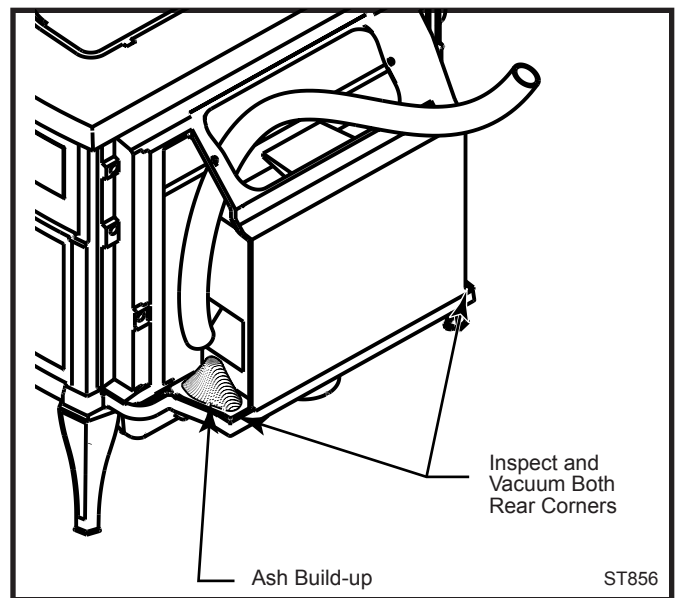
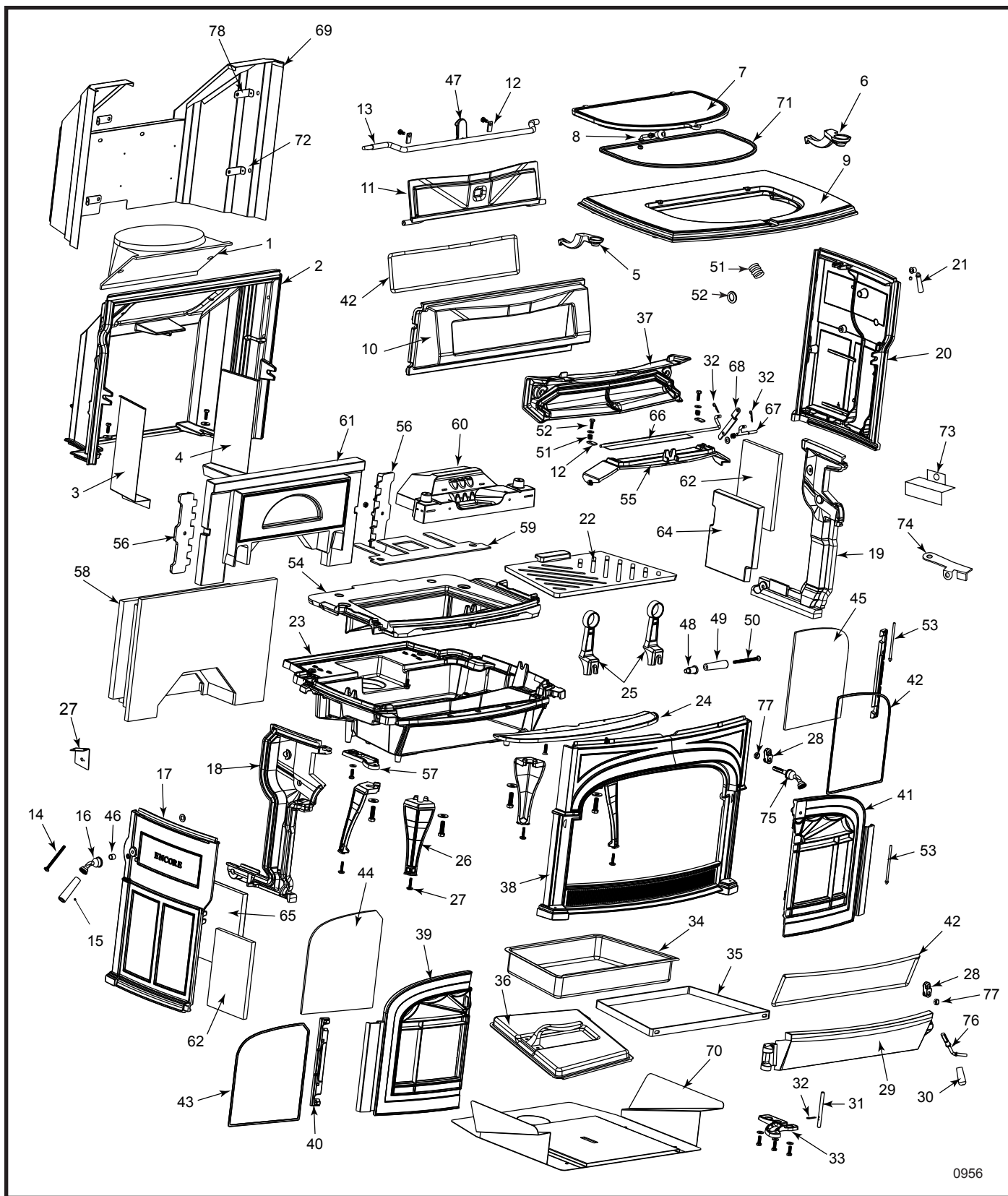

Fig. 48 Inspect and clean out ash accumulation on either side of the non-catalytic combustion system.



0956

MHSC reserves the right to make changes in design, materials, specifications, prices and discontinue colors and products at any time, without notice.

Encore Non-Catalytic Woodburning Stove

Model 1450

Encore Woodburning Stove

Model 1450 (continued)

Item Description	Part Number
1. Flue Collar (8")	See Chart Pg. 34
2. Inner Back	30002385
3. Left Heat Deflector	30002441
4. Right Heat Deflector	30002442
5. Left Griddle Quad	30002399
6. Right Griddle Quad	30002401
7. Griddle	30002386
8. Griddle Handle Assy	30002775
9. Top	See Chart Pg. 34
10. Damper Housing	30002413
11. Damper	30002389
12. Damper Tabs (3)	1601488
13. Damper Rod	1600851
14. Damper Handle Screw 1/4-20 x 3 3/8" NT	1201310
15. Damper Handle, Wood	1600664
16. Steel Handle Stub	30002720
17. Left Side	See Chart Pg. 34
18. Left Air Manifold (Inner side)	30002408
19. Right Air Manifold (Inner side)	30002409
20. Right Side	See Chart Pg. 34
21. Thermostat Handle Shaft w/set screw	30002716
21a. Thermostat Handle Wood	1600660
21b. Round Hd, SI 8-32 x 2 Screw	1201243
22. Grate	30002390
23. Bottom Outer	30002391
24. Ashlip	See Chart Pg. 34
25. Andiron (2)	30002397
26. Leg	See Chart Pg. 34
27. Leg Leveler	1201745
28. Pawl Assembly Short Adjustment	30002362
29. Ashdoor	30002392
30. Ashdoor Handle (Wood)	1600663
31. Ashdoor Hinge Pin	30002473
32. Cotter Pin, Ashdoor	30001749
33. Ashdoor Hinge Lower	30002404
34. Ashpan	1601025
35. Ashpan Bracket	1601039
36. Ashpan Cover	1601027
37. Airwash Manifold	30002407
38. Front	See Chart Pg. 34
39. Left Door	See Chart Pg. 34

Item Description	Part Number
40. Door Hinge Strip (2)	1308634
41. Right Door	See Chart Pg. 34
42. Door Gasket 5/16 Med. Density 6ND	1203588
43. Glass Gasket	1203556
44. Left Door Glass ¹	30002476
45. Right Door Glass ¹	1408629
46. Spacer 3/8 x 1-Z	1201779
47. Damper Ramp	1301811
Socket Set Screw Adjuster	1200436
PH Flat Hd Screw	1200809
Hex Nuts	1203210
48. Handle Base Stub	30002714
49. Wood Handle	1600664
50. Handle Bolt	1201310
51. Friction Spring	1201846
52. Washer	1202471
53. Pin, Long, Door	30002727
54. Inner Bottom	30002406
55. Primary Air Plate	30002415
56. Lower Brick Retainer	30002416
57. Hinge, Upper Ashdoor	30002403
58. Fountain Assembly CDW	30002100
59. Insul Gasket Shoe	30002418
60. Refractory Shoe	30002419
61. Refractory Lower	30002414
62. End Insulation	30002420
64. Right End Refractory	30002421
65. Left End Refractory	30002475
66. Primary Air Flap	30002443
67. Primary Air Shaft	30002841
68. Primary Air Linkage	30002445
69. Outer Back Assembly	30002450
70. Bottom Heat Shield	30002446
71. Griddle Gasket	1203668
72. Rear Side Bracket	30002457
73. Brick Support Bracket	30002480
74. Holder, Door Handle	30002909
75. Front Steel Handle w/Shaft	30002717
76. Ashdoor Handle Shaft	1600622
77. Hex Jam Nut	1203290
78. Bracket, Upper Side	30002667
79. Rheostat Bracket	30002863

1. Not interchangeable, due to a heat-reflective coating on the room side of the panels.

Shell Enamel Parts - Encore NC Model 1450									
Part Name	Classic	Biscuit	Bordeaux	Chestnut Brown	Ebony	Midnight Blue	Sand	Suede Brown	Vermont Green
Top	30002387	30003055	30002615	30003065	30003075	30002635	30002625	30002645	30003085
Left Side	30002388	30003052	30002613	30003062	30003072	30002633	30002623	30002643	30003082
Right Side	30002405	30003053	30002612	30003063	30003073	30002632	30002622	30002642	30003083
Flue Collar	1304280	30003008	2324280	30003020	30003032	2374280	1324280	30002527	30003045
Front	30002393	30003054	30002614	30003064	30003074	30002634	30002624	30002644	30003084
Ashlip	30002402	30003051	30002610	30003061	30003071	30002630	30002620	30002640	30003081
Left Door Subassy	30003974*	30003984	30003976	30003986	30003988	30003980	30003978	30003982	30003990
Left Door	30003938	30003958	30003950	30003960	30003962	30003954	30003952	30003956	30003964
Right Door Subassy	30003975*	30003985	30003977	30003987	30003989	30003981	30003979	30003983	30003991
Right Door	30003939	30003959	30003951	30003961	30003963	30003955	30003953	30003957	30003965
Single Leg	30002396	30003050	30002611	30003060	30003070	30002631	30002621	30002641	30003080

*NOTE: Does not contain glass or glass gasket.

LIMITED LIFETIME Warranty

For Vermont Castings Encore, Non-Catalytic Wood Stove

Limited Lifetime Warranty

MHSC warrants that all refractory brick and material used in this product will be warranted against deterioration not resulting from physical damage or overloading of the woodstove for the lifetime of this product. This coverage includes the components of the EverBurn System: "shoe, fountain, and fireback. Coverage is provided only to the original purchaser.

Limited 3 Year Warranty

All cast iron parts are warranted for a period of three years against breakage, cracking or burn-through.

Limited 1 Year Warranty

The following part of the woodburning stove are warranted to be free of defects in material and workmanship for a period of one year from the date you receive it: The handles, glass door panels, door gasketing and porcelain finish. Any of these items found to be defective will be repaired or replaced at no charge, upon the return of the part with postage prepaid to a Vermont Castings Authorized Dealer.

Any parts repaired or replaced during the limited warranty period will be warranted under the terms of the limited warranty for a period not to exceed the remaining term of the original limited warranty or six (6) months, whichever is longer.

Exclusions & Limitations

1. This warranty is non-transferable.
2. This warranty does not cover misuse of the stove. Misuse includes overfiring, which will result if the stove is used in such a manner as to cause one or more of the plates to glow red. Overfiring can be identified later by warped plates and areas where the paint pigments has burned off. Overfiring in enamel stoves is identified by bubbling, cracking, chipping and discoloration of the porcelain enamel finish. MHSC offers no warranty on chipping of enamel surfaces. Inspect your woodburning stove prior to accepting it for any damage to the enamel.
3. This warranty does not cover misuse of the stove as described in the Owners Guide, nor does it cover a stove which has been modified unless authorized by a MHSC representative in writing. This warranty does not cover damage to the stove caused by burning salt saturated wood, chemically treated wood, or any fuel not recommended in the Owners Guide.
4. This warranty does not cover a stove repaired by someone other than a Vermont Castings Authorized Dealer.

5. Damage to the unit while in transit is not covered by this warranty but is subject to a claim against the common carrier. Contact Vermont Castings Authorized Dealer from whom you purchased your stove or MHSC if the purchase was direct. (Do not operate the stove as this may negate the ability to process the claim with the carrier).
6. Claims are not valid where the installation does not conform to local building and fire codes or, in their absence, to the recommendations in our Owners Guide.
7. The salt air environment of coastal areas, or a high-humidity environment, can be corrosive to the porcelain enamel finish. These conditions can cause rusting of the cast iron beneath the porcelain enamel finish, which will cause the porcelain enamel finish to flake off. This warranty does not cover damage caused by a salt air or high-humidity environment.
8. MHSC shall have no obligation to enhance or update any unit once manufactured.

IN NO EVENT SHALL MHSC BE LIABLE FOR INCIDENTAL AND CONSEQUENTIAL DAMAGES. ALL IMPLIED WARRANTIES, INCLUDING THE IMPLIED WARRANTIES OF MERCHANTABILITY AND FITNESS, ARE LIMITED TO THE DURATION OF THIS WRITTEN WARRANTY. THIS WARRANTY SUPERCEDES ALL OTHER ORAL OR WRITTEN WARRANTIES.

Some states do not allow the exclusion or limitations of incidental and consequential damages or limitations on how long an implied warranty lasts, so the above limitations may not apply to you. This warranty gives you specific rights and you may have other rights, which vary from state to state.

How to Obtain Service

If a defect is noted within the warranty period, the customer should contact a Vermont Castings Authorized Dealer or MHSC if the purchase was direct with the following information:

1. Name, address, and telephone number of the purchaser
2. Date of Purchase.
3. Serial number from the label on the back
4. Nature of the defect or damage.
5. Any relevant information or circumstances, e.g., installation, mode of operation when defect was noted.

A warranty claim will then start in process. MHSC reserves the right to withhold final approval of a warranty claim pending a visual inspection of the defect by authorized representatives.

MHSC

149 Cleveland Drive • Paris, Kentucky 40361
www.mhsc.com