

Vermont Castings®
CANADIAN
OPERATION
MANUAL



For the
Defiant® Vigilant® Resolute®
Intrepid®
Wood Parlor Stoves







CANADIAN OPERATION MANUAL UPDATE

Save These Instructions for Future Reference

#22671

4/86

Safety, and the enjoyment of your stove, are closely tied together. Your understanding and observance of safe installation, operation and maintenance procedures will help you gain the greatest possible satisfaction from your stove. This information sheet will help you review some important safety considerations.

1. Save the instructions and keep them available for reference. If you sell your stove, deliver the manual with the stove. Please read all of the information in the Vermont Castings Canadian Operation Manual and the instruction sheets which came with accessories. They are important parts of your stove.

2. Do not make unauthorized changes to your stove. Your stove is tested and listed by Underwriters' Laboratories of Canada. Any modification not authorized by ULC and the factory could result in your having an untested stove, and could result in a hazardous condition.

3. Do not take short cuts with your installation. "Make-shift" compromises may result in a hazardous condition. The clearance reductions using rear stove and stovepipe heat shields shown in the Canadian Operation Manual have been carefully tested. They are included in our listing with Underwriters' Laboratories of Canada (ULC). Do not make any clearance reductions not approved by ULC.

Your manual gives step-by-step instructions for installing your stove and the chimney connector (the pipe which connects the flue outlet of your stove to the chimney). Pay careful attention to all the details.

4. DO NOT USE CHEMICALS OR FLUIDS TO START OR RE-ESTABLISH THE FIRE. Your manual gives instructions for starting and maintaining a fire. Especially when using green or unseasoned wood, you may be tempted to take short cuts in getting the fire started, or building the fire up after it has burned low. Don't!

5. DO NOT BURN GARBAGE OR FLAMMABLE FLUIDS SUCH AS GASOLINE, NAPHTHA OR ENGINE OIL. Hardwood which has been cut to length, split and stored under cover for a year is a very good fuel. Properly seasoned softwood also burns well, but is less dense and will provide less heat per full load of wood. Unseasoned wood will burn but more stove tending and chimney maintenance may be required.

Do not burn other material in your stove.

6. Operate your woodburning stove with the doors open or closed, but do not operate it with the doors part way open. As you become more experienced burning your stove you will probably be able to enjoy longer and more efficient fires with less stove tending. However, continue to pay attention to safe operating practices.

7. Store fuel where it will be safe and out of the way. Storing fuel close to the stove is convenient but be sure it is at least as far from the stove as the required clearance distance shown in the Chart of Clearances in the operation manual. Store it where it will not interfere with loading the stove or removing ashes.

8. Load the right amount of wood in your stove to provide the stove performance you want. For a long burn with high heat output, you may load wood to the top of the fireback but be sure the wood does not interfere with closing the griddle or closing the damper. Remove wood which is in the way.

When heating needs are light, burn small hot fires with modest loads of wood and leave the damper open. This technique can provide a good combination of moderate heat in the room and sufficient heat in the flue to keep the draft strong and minimize creosote accumulation. More frequent loading will be required. Avoid slow, smoldering burns as they may lead to rapid creosote build-up.

9. **Dispose of ashes properly.** Ashes removed from an operating stove may give off heat and gases for several days. Dispose of ashes in a metal container with a tight fitting lid. Place the metal container outside the house on a non-combustible floor away from all combustible material.

10. **Be sure the fire can get enough air for good combustion.** Draft in the stove and chimney draws air from the room to the fire. In most older homes, enough air leaks into the house so that the draft has no trouble drawing room air into the stove. However, in some new, very well insulated homes, it may be necessary to provide an air duct to bring outside air directly to the air inlet of the stove or to the room where the stove is installed. Bringing in outside air will ensure that draft is not affected by varying pressures in the home. Poor stove performance may indicate the need for outside combustion air.

Except in the case of a chimney fire, the air inlet shutter should always be a little way open to allow some air into the stove.

11. **Provide your stove with a proper chimney system.**

The chimney connector for the Defiant and Vigilant should be 8" in diameter. The chimney connector for the Resolute and Intrepid should be 6" in diameter. The chimney connector must not pass through a floor or ceiling or pass through any concealed space such as a closet. Do not pass the connector through a combustible wall if it can be avoided. For approved methods of passing a connector through a combustible wall, refer to the Installation Code for Solid-Fuel Burning Appliances and Equipment, CSA-B365. The connector must always be visible and accessible for inspection and cleaning.

The chimney for the Defiant and Vigilant should have a liner at least 8" in diameter or 8" x 8" (nominal measurements). The chimney for the Resolute or Intrepid should have a liner at least 6" in diameter or 8" x 8" (nominal measurements).

Chimneys larger than 8" x 12" may allow rapid cooling of flue gases and lessening of draft. When a small stove is vented into a large chimney, especially a large exterior masonry chimney, the stove may have to be operated with the damper open much of the time to direct heat to the flue, or the chimney may need to be insulated or re-lined.

12. **If your stove has glass panes in the doors:**

- * The glass will need to be cleaned. Be sure the glass is completely cool. Use a glass cleaner formulated for cleaning stove glass. Do not use abrasives. Remove all traces of the cleaner before re-firing the stove.
- * Vermont Castings uses high temperature ceramic glass. Treat it with care. Although it is very durable, it can be damaged if it is dropped or struck with a hard object, or if stove doors are slammed shut. If it needs to be replaced, use only Vermont Castings high temperature ceramic glass. Do not use substitutes.

- * Directions for installing glass may be found in glass replacement kits, or in glass accessory kits. If you have questions, call your local authorized dealer.
- * Do not operate your stove if glass in the doors is broken as your control of the air supply and combustion rate may be reduced.

LOOK FOR AND REPAIR THESE DEFECTS:

- A. Improper chimney height and roof clearance. Check local building codes for proper construction.
- B. Chimney cap deterioration: should be rebuilt.
- C. Creosote stains indicate flue damage: inspect and repair.
- D. Blockage within flue: must be removed.
- E. Improper clearance between chimney and combustible materials. Generally, a clearance of 2" is required to all combustible walls and framing members. Check local codes.
- F. Improper clearance between smoke chamber and adjacent framing members. Check local building codes.
- G. Creosote accumulation: chimney needs thorough cleaning.
- H. Structural deterioration of the fireplace: must be repaired before use.
- I. Loose or broken bricks or mortar; replace and remortar.
- J. Loose or broken clean-out door: repair or replace.

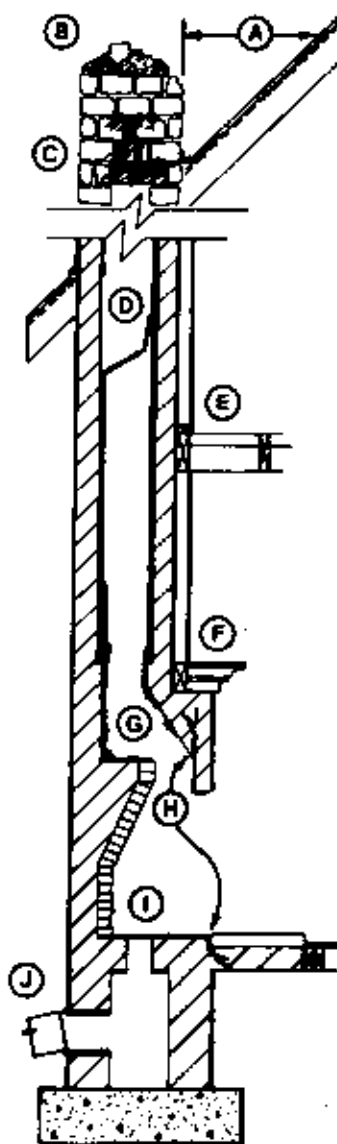

WELCOME

Buying a wood stove, especially a highly sophisticated one like ours, is a commitment. As an owner of one of the finest stoves made, you make a commitment toward a lifestyle founded on the notion that one technology does not replace another, but allows us to become reconnected to the natural systems which support us. In doing so we acquire a new vocabulary. This operations booklet summarizes our knowledge. Combined with your effort, it will provide the tools you need to reach your goals. We at Vermont Castings feel that your commitment to your new stove, in some cases a very new experience, will be amply rewarded.

We encourage you to familiarize yourself with this manual before setting up your stove. Become familiar with the parts of the stove and their functions, so that it will be easier to follow the advice in the sections of the manual which follow. The clear chapter headings should facilitate your task. Read the chapters in order. If you have already completed your plans and the work necessary for installation, you might like to move ahead to the chapter on setting up the stove. Once again we caution you please to read through the material at least once before you make the final installation connection and build your first fire.

This operation manual is an important part of your stove and should always be kept on hand for future reference. We suggest that you read it again after the stove has been in service for a while. Also, be sure to transfer this manual with any sale of the stove.

INDEX

- 2 The Inside Story
- 5 The Intrepid
- 6 Installation
- 10 Operation
- 12 Maintenance
- 15 Stove Dimensions

SAFETY NOTICE:

IF YOUR DEFLIANT, VIGILANT, RESOLUTE OR INTREPID IS NOT PROPERLY INSTALLED, A HOUSE FIRE MAY RESULT. FOR YOUR SAFETY, FOLLOW THE INSTALLATION DIRECTIONS. CONTACT LOCAL BUILDING OR FIRE OFFICIALS ABOUT RESTRICTIONS AND INSTALLATION INSPECTION REQUIREMENTS IN YOUR AREA.



THE INSIDE STORY

Economics & Efficient Combustion The How & Why

SAVINGS are one of the benefits that you can expect from your stove. To gain maximum savings and pleasure from your stove, you must understand its efficiencies and inner workings. This knowledge is as important for installation as for daily use. That is why this section on the efficiency and combustion principles of the stoves is included before you reach the installation information. Please read it before you begin.

Our four stoves share the same design and combustion principles. The Intrepid differs a little in interior arrangement and air flow patterns. Intrepid owners, see The Intrepid, page 3.

Let us start your tour of the inner workings of the stoves with a discussion of *side draft*, the fundamental concept behind the efficient operation of our wood stoves. In *side draft* combustion, the flames move horizontally as they leave the primary combustion zone. Most stoves employ *updraft* combustion, in which flames rise up through the fuel load. All wood loaded into an updraft stove immediately becomes part of the fire mass unless oxygen is restricted to a very low level. Our horizontal flamepath allows only the bottom of the wood load to burn. The logs on top are dried by heat and fall into the flame area as those below are consumed. Thus, a full wood load can provide heat all night long.

The use of side draft combustion allows us to place the fuel in a magazine where the fueling of the fire is automatically accomplished by gravity. All of our stoves, both wood and coal, are magazine burners providing maximum efficiency with minimum tending.

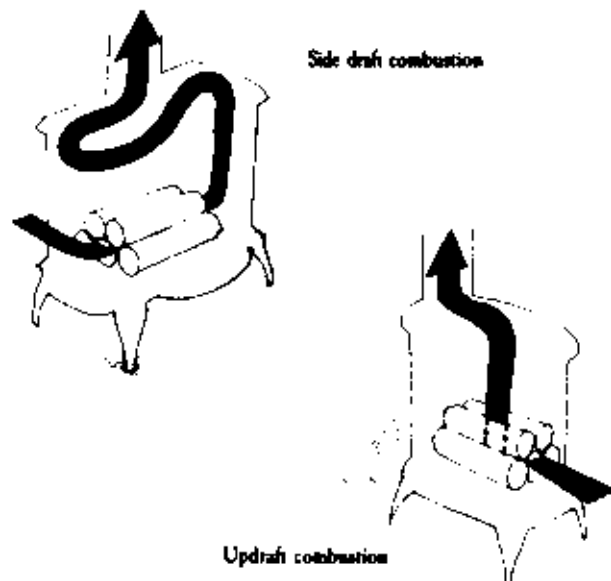

Fuel Limiting:

The Ultimate Control System

There are two ways to control the volume of power output in a combustion device: fuel limiting and oxygen limiting. An automobile is fuel-limited. If you need more power, you supply the engine with more fuel.

An updraft stove places the entire fuel supply in the combustion zone at once. In order to control the combustion in an updraft stove, the fire is partially smothered, creating thick smoke. Our magazine system uses no more than the amount of fuel necessary in the combustion zone at any one time in order to produce the maximum amount of heat for which the stove was designed. In order to slow the fire below these points, we use oxygen limiting with an automatic thermostat which provides the fire with an appropriate level of oxygen.

Air Systems

Primary Air Systems

In our stoves, oxygen enters at the thermostatically controlled *Inlet Air Shutter* and travels through passages where it is heated before being fed to the fire mass through the *Primary Air Ports*. When a fuel is heated and burns, the combustible gases naturally locked in it are driven off.

Secondary Air Systems

Our stoves facilitate the burning of these volatiles in two ways. By using side draft combustion, the gases are forced to pass close to hot coals which maintain a high temperature for ignition.

Our stoves also employ a sophisticated system which introduces another source of preheated air (secondary air) at the proper place to encourage combustion of these volatile gases. The secondary combustion of gases that, because of an insufficient oxygen supply, were unable to ignite within the primary combustion zone are encouraged to release their heat.

The Damper

The damper is the last of the important internal parts. In its vertical or up position, the damper is closed and flames exit from the stove by way of the long flamepath described, allowing the side draft combustion mode. When lowered flat, the damper is open and the stove is converted to an updraft combustion device, allowing flue gases to escape directly from the

Heat-regulating Thermostat.

Automatically controls air intake to assure steady, even heat all day, all night long.

Two-Position Damper.

Lowered, permits use as fireplace; raised, helps provide maximum heating efficiency.

Secondary combustion chamber.

Allows unburned gases to combine with oxygen, providing additional heat.

The baffle.

Creates a longer flamepath for maximum heat transfer.

Primary air entry ports.

Disperse preheated air evenly into combustion zone.

Smoke Shelf.

Directs exhaust gases into upper chamber, where they release additional heat before rising up flue.

Secondary air tube.

Feeds preheated oxygen to secondary combustion chamber.

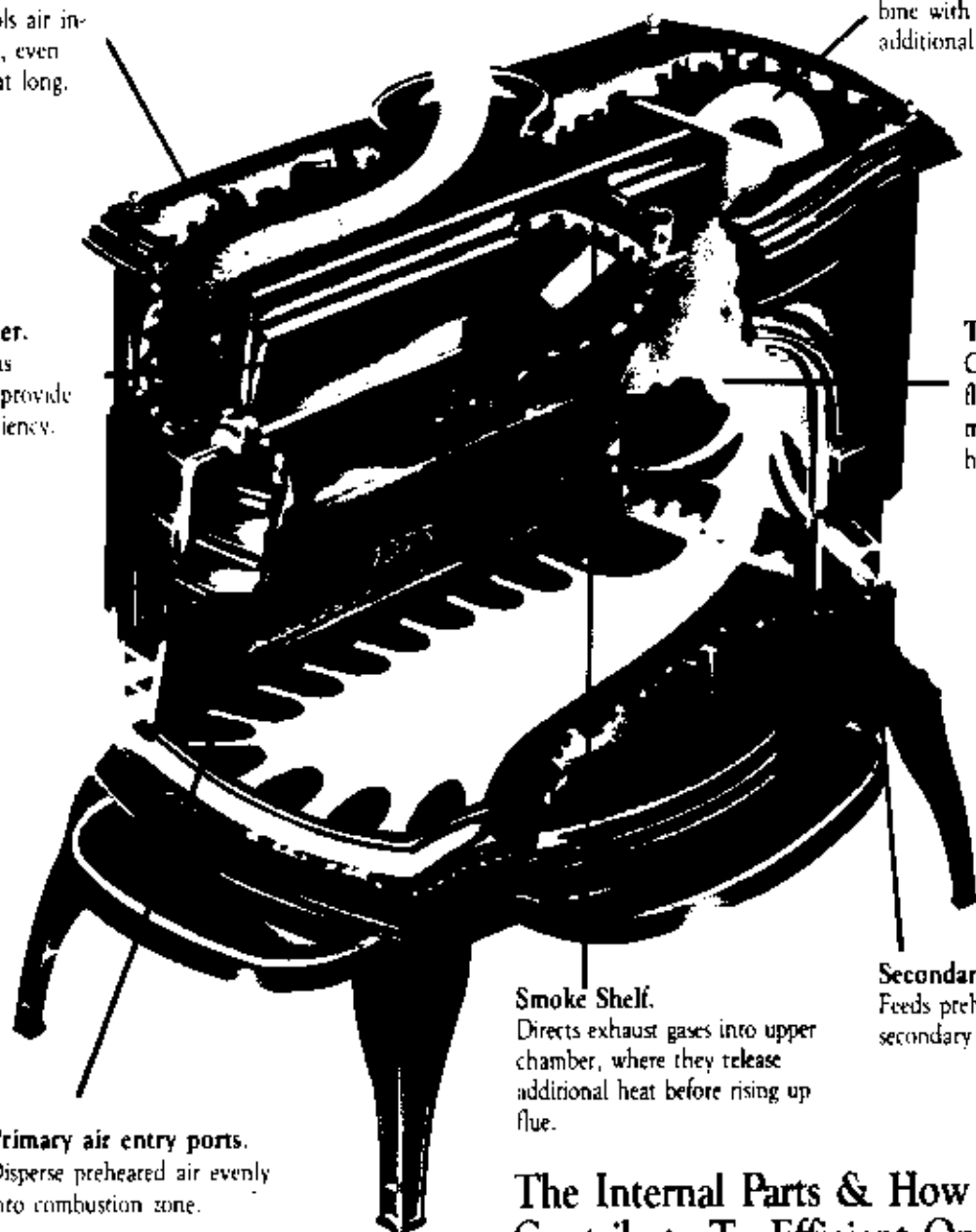

The Internal Parts & How They Contribute To Efficient Operation

Secondary Combustion

Secondary air enters the Defiant, Vigilant and Resolute at the lower left-hand end of the stove through the circular *Secondary Air Entrance Port*.

Under normal conditions, this remains open all the way at all times. This air passes down the *Secondary Air Tube* where the oxygen is preheated. The oxygen source is then directed into the *Secondary Combustion Chamber* through numerous air ports, ensuring a thorough mixing of preheated oxygen with the combustible gases.

This mixture is then ignited by flames as it leaves the primary combustion chamber. A *Secondary Combustion Chamber* allows the gases to expand as they are further heated by their own combustion. A large portion of the stove's exterior surface encloses this chamber, thus allowing for transfer of the maximum possible amount of heat to the room.

magazine into the chimney connector. (The various requirements of the two functions are explained in the section titled "Operation.") It is important to note the relation of the handle to the damper. On the Defiant, Vigilant, and Intrepid, when the damper is closed, both it and the handle are vertical. On the Resolute, the spirally bound wire handle is down when the damper is closed, and up when it is open.

Smoke will come out of any opened loading door if the damper is closed. The interlock with the damper handle and the loading door on the Defiant is designed to prevent opening the door while the damper is closed. The griddle of the Vigilant will not open all the way should you forget to lower the damper first. These serve as reminders that you can only load wood smokelessly when your stove is in an updraft configuration.

In spite of the careful research and design work that went into our stoves, we do not want to mislead you about combustion efficiency and secondary combustion.

Complete combustion of wood is a relatively easy thing to accomplish with either wood chips or wood flour, where air, moisture content, and draft are consistently controlled. This is how large commercial installations operate. With non-uniform logs, variable moisture content, and an unknown draft quotient, complete combustion is more difficult to attain. Your careful attention to properly pre-heating the stove and flue before closing the damper, to burning seasoned wood, and to maintaining a clean, tight installation will help achieve high combustion efficiency.

Behind the Fireback are the smoke passages. These passages consist of a series of Baffles which conduct the flue gases in a serpentine manner back and forth across the length of the stove. The gases are channeled close to the thermostat coil in order to give it maximum sensitivity to the changing fire conditions within the stove. The back of the Vigilant and the back and sides of the Resolute have been deeply convoluted, like old Victorian steam radiators, to provide a larger surface of cast iron.

The Flamepath

The *Secondary Combustion Chamber*, taken together with the smoke passages, make up the flamepath.

The Defiant's sixty inch flamepath is one of the longest of any cast iron stove currently on the market. The Vigilant flamepath measures fifty-five inches; the Resolute fifty inches. A long flamepath is important to the heating capability for two reasons. The considerable heat of the flue gases is transferred to the surface of the stove, where in turn it is given off to the room, rather than being lost up the chimney. Secondly, because the passages are adjacent to the combustion chamber, higher temperatures are encouraged within the fire mass itself, which aids in the burning of the volatiles. It can easily be seen that unless the flamepath is concentrated tightly within the stove, the heat of the flue gases will not contribute to the temperature of the primary fire mass, nor will the gases maintain their necessary high temperatures in order to ensure combustion of the volatiles.

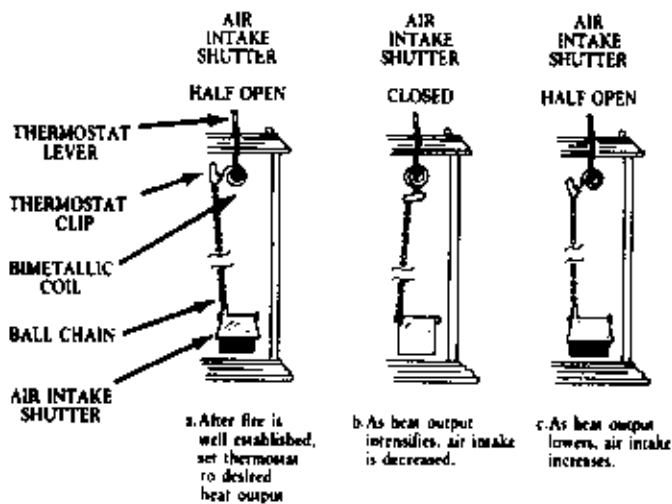

THERMOSTAT OPERATION

- View of thermostat for Defiant and Vigilant is with thermostat cover removed
- Resolute bimetallic coil is reversed
- Intrepid lever is pushed back to open air shutter, pulled forward to close air shutter.

The Thermostat

The heat output of the stove can be regulated to accommodate individual heating requirements by setting the thermostat lever (a). The bimetallic coil to which the lever is attached will contract or expand in response to the heat from the stove. Consequently, through connection to the coil by the ball chain, the air intake shutter will open or close, thus regulating the flow of incoming combustion air. The result is that as heat output intensifies, the air supply is decreased (b). The combustion rate slows, heat output drops, and the air supply is again allowed to increase as the bimetallic coil reopens the air intake shutter (c). The overall heat output throughout the burn period is determined by the initial lever setting.

The length of burn period is similarly related to the lever setting as a high heat output will necessarily allow faster fuel consumption than will a lower heat output setting. You will gain the most efficient use of your stove and fuel by setting the thermostat to allow a moderately hot fire. Long, smoldering burn periods should be avoided.

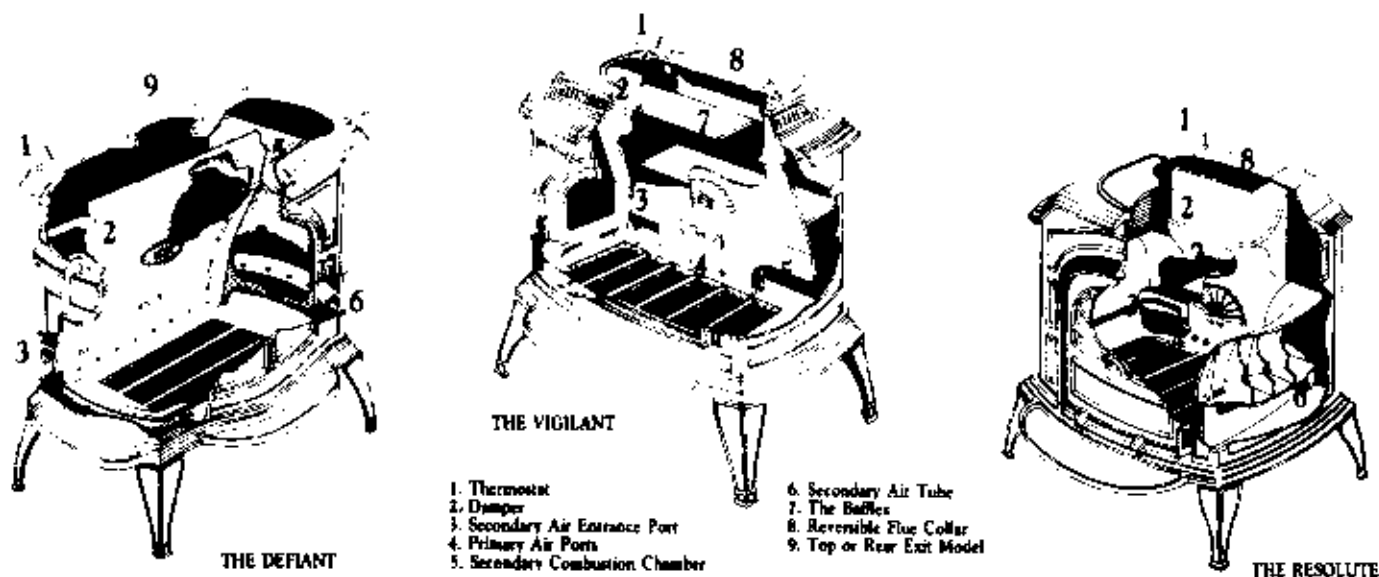

THE INTREPID

The Intrepid is designed with several features that differ from our three larger parlor stoves. Air flow patterns, ash removal and maintenance procedures specific to the Intrepid are described here. Basic combustion principles remain the same for all four stoves, so the operation and installation sections of the manual apply equally well to the Intrepid.

Air Flow

Glass doors for fire-viewing are a standard feature in the Intrepid. Air flow through the stove is designed so pre-heated air washes past the glass to prevent carbon deposits from forming.

Combustion air enters through the air inlet in the back of the stove, passes forward through the air tubes at the left and right sides of the bottom of the stove and flows past the glass.

Some of the air goes directly back through the fire mass and provides air for combustion in the primary combustion zone. Excess air flows over the fire mass and contributes to further combustion.

Updraft Operation

When the damper is open (handle pointed forward) the stove is in the updraft mode. Fire and smoke leaving the primary combustion zone go directly to the flue collar and chimney connector. These exhaust gases carry heat to the flue. A warm flue is helpful in establishing and maintaining good draft. Updraft operation will be used when starting a fire, loading your stove, or enlivening the fire after a long burn. It may also be used anytime a warmer flue will provide better performance.

Side-Draft Operation

When the damper is closed (handle pointed down) the stove is in the side-draft mode. Fire and smoke leaving the primary combustion zone are directed through the louvers in the Upper Fireback, down through the firebrick-lined secondary chamber then to the flue collar and chimney connector. The high temperatures maintained in the secondary combustion chamber encourage further burning of volatile gases in the smoke. Side-draft operation will usually be used during extended burns.

Ash Handling

Slots in the bottom grate allow ash to fall through into the ash pan. Slicing the ashes on the bottom grate with the slicer/poker will help the ashes fall through the slots.

Empty the ash pan once a day or as necessary to keep the ash pan from overflowing. Use the hook on the end of the slicer/poker to pull the ash pan part way out of the stove. Wear heavy gloves as you draw the pan out of the stove and dispose of the ashes properly. Your metal ash container must have a tight-fitting lid and be located outdoors, away from any combustible material.

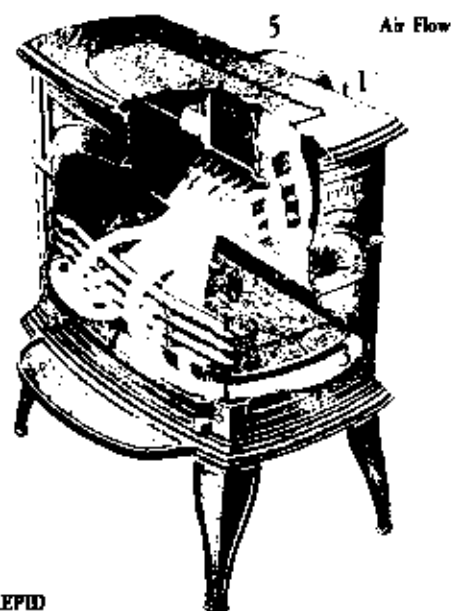

THE INTREPID

1. Thermostat
2. Damper
3. Air Ports
4. Firebrick-Lined Secondary Combustion Chamber
5. Reversible Flue Collar
6. Bottom Grate
7. Ash Pan

When you replace the ash pan in the Intrepid, be sure it is seated properly and pushed all the way to the rear of the stove so it does not block the front ends of the air tubes. Too much ash on the bottom of the stove may prevent proper seating of the ash pan.

Fireplace Operation

With the stove damper in the open position, and the front doors open, a wood stove may be used as a fireplace. It is ideally suited for those times when you do not require a great deal of heat output such as in the spring and fall, or when you want to enjoy the romance of a crackling fire. Always keep the sparkscreen in place when the doors are open.

Thermostat Function

Whenever the front doors are closed, all air entering the stove is regulated by the air intake shutter which is linked to a bimetallic thermostat coil and lever at the right side of the flue collar. Push the lever back to admit maximum air for hotter fires. Pull the lever forward to reduce air and slow the combustion rate. The bimetallic coil and, consequently, the air intake shutter, continually open and close in relation to temperature fluctuations within the stove to maintain an even heat output. Generally, the lever should be kept in medium to high setting. Very long, smouldering wood fires should be avoided.

INSTALLATION

Set Up

Installing the Bottom Heat Shield and Legs

Our stoves are quite heavy and require at least two people to move and set them up. You may want to remove the accessories that come with the stove, the front doors, and the griddle, to make carrying the stove a bit easier. Place the stove close to its final position before installing the bottom heat shield and legs. **DO NOT TRY TO MOVE THE STOVE ALONE AS IT CAN BE DAMAGED BY MISHANDLING.**

The bottom heatshield has been designed to reduce the degree of radiant heat to the area directly beneath the stove. The shield mounts between the legs using the 4 C-brackets and wing nuts provided.

Bottom Heat Shield Installation

- * Close the damper.
- * For the Defiant, Vigilant, and Resolute, gently tilt the stove forward until the top plate and ashlip are resting on the floor. For the Intrepid, tip the stove onto its back.
- * Remove the temporary 1/2" bolts from the leg bolt holes and discard them.
- * Fasten the legs loosely to the stove bottom using the leg bolts that are provided with your stove. Use one washer on each leg.
- * The shield will be mounted with the reflective side toward the stove bottom, and painted side toward the floor.
- * Mount the C-brackets onto the shield by inserting the 1/2" wing nut bolts through the shield holes from the shield's painted side, then hand tighten the C-brackets into place.
- * Lift the shield into position with the long tapered portion of the shield facing downward (this will extend under the ashlip).
- * Rotate the two front C-brackets on the shields so that they will slide into place between the washer and the legs.
- * Rotate one of the rear C-brackets into position, hold the corresponding leg in position, then insert and tighten the leg bolt. Repeat this procedure for the other rear leg. Snug up all four leg bolts.
- * **CAUTION: DO NOT OVERTIGHTEN THE LEG BOLTS, AS THIS MAY STRIP THE THREADED CASTING.**
- * Hand tighten the shield wing nuts.
- * Lift the stove carefully into the upright position on the hearth. We recommend that you clean the bottom heat shield when necessary, to maintain its heat reflective value.

Vigilant owners, cover the bottom of the stove with the refractory cement supplied with the stove.

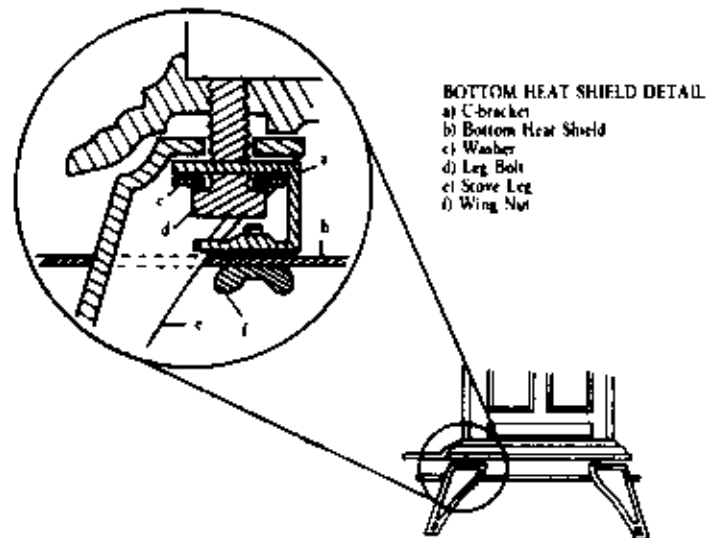

Placement

Stove placement is crucial for even heat distribution in your home. Since a radiant stove depends upon efficient air circulation to disperse its heat, a central location in the house or in the living area is best. However, your installation may be influenced by the position of an existing chimney flue, by critical clearances to combustible walls or by accessibility to the loading door.

We are prepared to help you with questions concerning placement. You are welcome to contact us directly at the factory with floor plan sketches, or you can contact our authorized stove dealers.

Clearances

The Chart of Clearances, page 7, lists recommended minimum clearances to combustibles. In addition to walls, ceilings, and floors, it is important to keep all combustible room furnishings, such as draperies and sofas, at least 36" away from the sides of the stove and 48" from any front or side loading door.

The distance from the rear of the stove to combustible walls can be reduced, as shown in the chart, through the use of our stove and stovepipe heat shields. The stovepipe and rear heat shields are spaced about two inches from the back of the stove and act as a barrier to radiant energy, reflecting heat forward into the room.

The heat shields are painted black on the outside with Vermont Castings high temperature stove paint in order to match the stove. Hardware and complete instructions are supplied with the heat shields so that they can be easily installed before the stove is connected to the chimney.

Chimneys

The choice between a free-standing installation or one installed into a fireplace flue will depend upon what you have available, the condition of the chimney and how the stove will look in place. A masonry chimney must conform to provincial regulations or, in their absence, the requirements of the National Building Code. An existing fireplace flue can make an excellent chimney provided it is in sound condition and the stove is installed according to the provisions of CSA-B365. We recommend that, prior to installing your stove into any masonry chimney, you have the chimney inspected by a qualified mason. The chimney and installation will have to be inspected and approved by your local building inspector. If your chimney is unlined, we cannot recommend that you use it in its existing state with any wood or coal-burning device. If you have any questions about the safety of your installation, don't hesitate to contact your local building official or your Vermont Castings stove dealer. If a prefabricated chimney is being used, it must be a solid-fuel type Underwriters' Laboratories of Canada Labelled Factory Built Chimney, installed in accordance with the manufacturer's instructions.

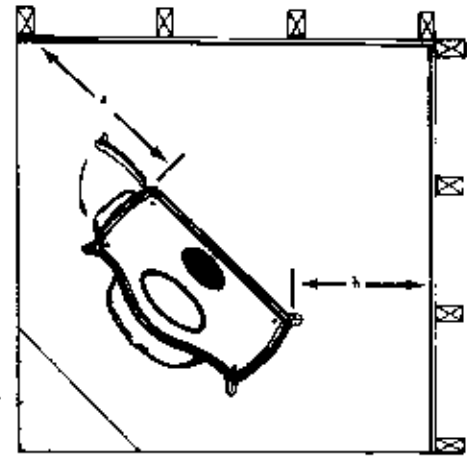

FIG. 1—Top Exit Defiant—Corner Installation—
No Protection—Combustible Wall
a = Min. 48" (1,220 mm) from Lead Door End to wall
b = Min. 36" (915 mm) from Rear Corner to wall

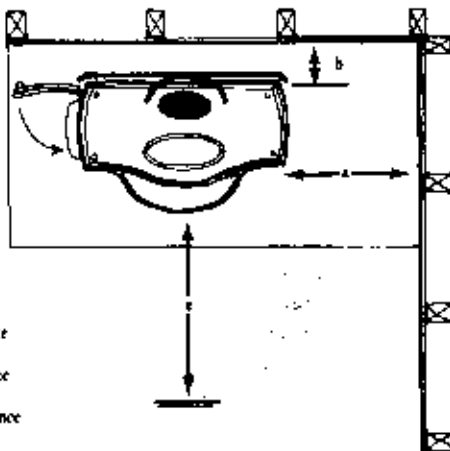

FIG. 2—Top Exit Defiant—Side Installation—
Rear Heat Shield & Pipe Heat Shield—Combustible Wall
a = Min. 36" (915 mm) clearance from side to wall
b = Min. 14" (356 mm) clearance from rear to wall
c = Min. 48" (1,220 mm) clearance from lead or front doors to any combustible materials, i.e., furniture

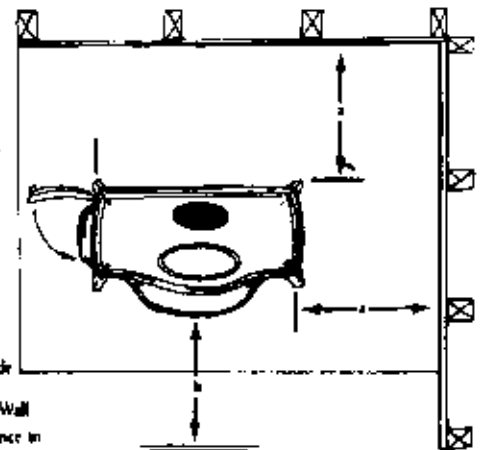

FIG. 3—Top Exit Defiant—Side Installation—
No Protection—Combustible Wall
a = Min. 36" (915 mm) clearance in wall from side to rear
b = Min. 48" (1,220 mm) clearance from lead or front doors to any combustible materials, i.e., furniture

| CHART of CLEARANCES ¹ | Defiant-Vigilant-Resolute | | Intrepid | |
|---|---------------------------|-------------------------|---------------------------|------------------------|
| | Without Rear Heat Shields | With Rear Heat Shields | Without Rear Heat Shields | With Rear Heat Shields |
| FRONT | 48" - 122cm | 48" - 122cm | 48" - 122cm | 48" - 122cm |
| REAR | 36" - 92cm | 14" - 36cm | 30" - 76cm | 16" - 40cm |
| SIDE | 36" - 92cm ² | 36" - 92cm ² | 24" - 61cm | 24" - 61cm |
| CORNER <small>Distance measured from rear corner of stove to wall.</small> | 36" - 92cm | 24" - 61cm ¹ | 20" - 50cm | 20" - 50cm |
| STOVEPIPE | 18" - 46cm | 12" - 30cm | 18" - 46cm | 12" - 30cm |

¹ Established in accordance with Underwriters' Laboratories of Canada Standard ULC S627 by Underwriters' Laboratories of Canada, Scarborough, Ontario.

² 48" required on leading door side of Defiant.

³ Stovepipe heat shields not required.

Stovepipe

The Defiant is available as either a top-exit model or a rear-exit model. The Vigilant, Resolute and Intrepid have reversible flue collars to easily accommodate top or rear-exit installations.

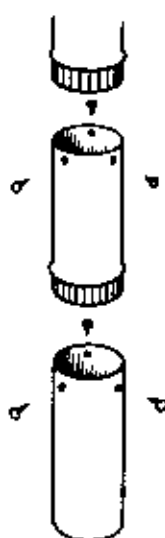

The minimum stovepipe size recommended for use with the Defiant and Vigilant is eight inches. A variety of starter pieces, formed to fit the Defiant and Vigilant oval flue collars, are available from Vermont Castings. Resolute and Intrepid flue collars accept standard six inch stovepipe. Stovepipe sections should be arranged with crimped ends down so any creosote falling down will stay inside the pipe.

When enamel pipe is used with Vigilants and Resolutes, the first section will be a special starter piece.

Three 3/16" holes have been drilled into the flue collar to secure the chimney connection to the stove using the sheet metal screws included in the Leg Bolt Package.

All stovepipe should be made from .53 mm (24 gauge) sheet steel (or heavier) to provide adequate stiffness and durability.

A full line of piping accessories is offered by Vermont Castings to ensure the maximum flexibility in designing your system.

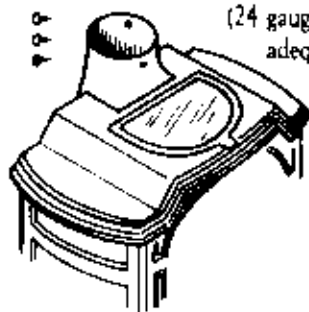

Stovepipe Dampers

Stovepipe dampers are not necessary in our stoves. Not only is this an unnecessary restriction in the flue, but it is an additional surface directly in the path of flue gases upon which deposits can form, creating the potential for either a chimney fire or draft blockage. An airtight stove controls oxygen introduction at the source by its inlet air shutter system, so no flue damper is required.

Chimney Connector

The series of stovepipe sections used to connect the stove to the chimney is called a chimney connector. Care must be taken in designing your chimney connector to minimize potential hazards.

The following points should be observed:

- The connection should be as short and direct as possible to effectively duct the exhaust gases and smoke into the chimney. Do not use more than two elbows as additional turns will tend to reduce the draft.
- Secure each stovepipe joint with three sheet metal screws. Keep in mind that you will have to remove the stovepipe from time to time for periodic inspection and cleaning.

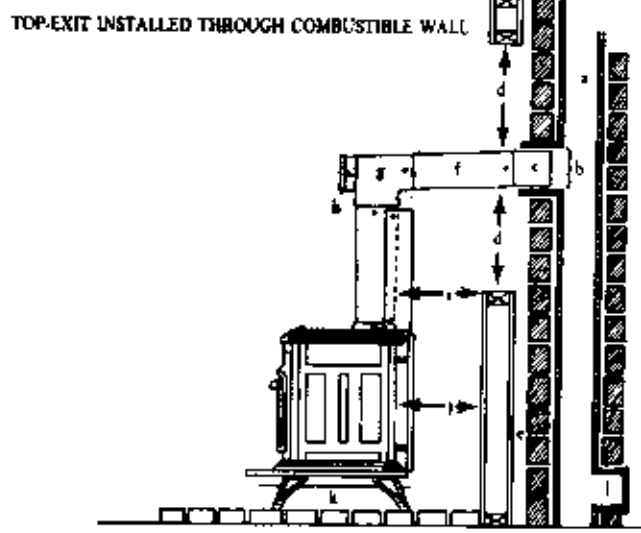

- a) Tile-lined masonry chimney built to or in compliance of National Building Code standards
- b) Thimble
- c) Stovepipe should not project into flue
- d) Min. 18" (460 mm) clearance between stovepipe and combustible materials (Alternative methods must meet C.S.A. code B-365)
- e) Min. 2" (51 mm) clearance between chimney and combustible materials
- f) Min. 4" (6.55 mm) rise per 1 foot (305 mm) horizontal run
- g) Stovepipe inspection & clean-out tee
- h) 3 sheet metal screws at each stovepipe joint
- i) Stovepipe hear shield allows 12" (305 mm) clearance to combustible materials
- j) Rear heat shield allows 14" (356 mm) clearance to combustible materials
- k) Bottom heat shield is 3/8" noncombustible material provides hearth protection
- l) Clean out access for right door

- Single wall stovepipe cannot serve as a chimney and therefore it must never pass through a combustible ceiling. Such passages are serious fire hazards.
- Single wall stovepipe can only pass through a combustible wall with adequate clearances. Clearances are 18" from combustible materials. See Chart on Clearances. Refer to the Installation Code for Solid-Fuel Burning Appliances and Equipment, CSA-B365, for approved methods of passing stovepipe through a combustible wall. Also, refer to the illustration above for one method.

Vermont Castings offers a Connector Pipe for Prefabricated Metal Chimneys for forming a telescoping joint between a double-wall insulated chimney and single-wall smokepipe. The Connector Pipe is secured to the double-wall chimney. A section of standard stovepipe slides up and down on the Connector Pipe. The telescoping joint makes connecting or disconnecting the stovepipe easy.

Floor Protection

Even though temperatures under our stoves are significantly lower than those to the sides of the stoves due to the effectiveness of the Bottom Heat Shield, no stove should ever be installed on a combustible surface because of the possibility of falling embers. Our stoves have generous protective ashtraps, but some coals may escape from time to time.

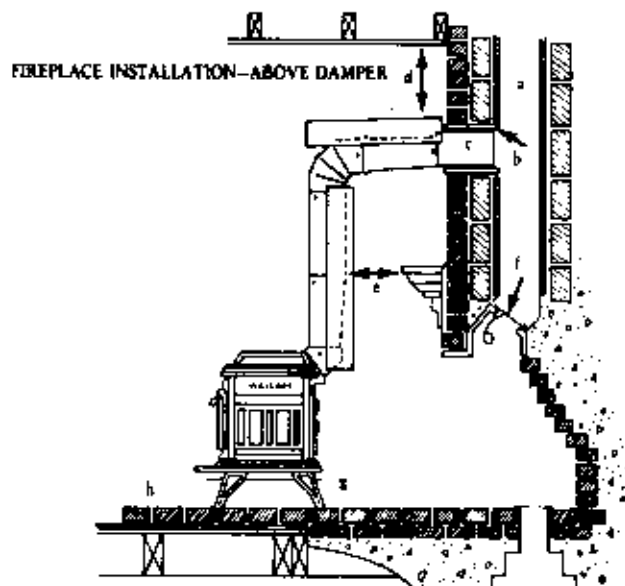

- FIREPLACE INSTALLATION—ABOVE DAMPER**
- a) Tile-lined masonry chimney built to or in compliance of National Building Code standards
 - b) Thimble
 - c) Stovepipe should not project into flue
 - d) Horizontal pipe heat shield allows min. 12" (305 mm) clearance to combustible ceiling
 - e) Vertical pipe heat shield allows min. 12" (305 mm) clearance to combustible masonry
 - f) Damper closed and sealed
 - g) Bottom hear shield protects combustibles beneath hearth
 - h) Hearth extension provides floor protection min. 18" (460 mm) from stove front load door and 8" from side of stove

Approved floor protectors consist of a layer of noncombustible material at least 3/8" thick or 1/4" thick covered with sheet metal. This protector must extend at least 18" in front and 8" to the sides and rear. In the case of the Defiant allow 18" on the loading door side of the floor protector.

With legs installed, the hearth in place, the flue connections made, and the stovepipe connections secure, the only additional preparation that needs to be done is the addition of a 1 1/2" layer of sand or ashes in the bottom of the Defiant or Resolute, or the layer of refractory cement (supplied with the Vigilant) in the bottom of the Vigilant. The Intrepid does not require an insulating layer on the bottom.

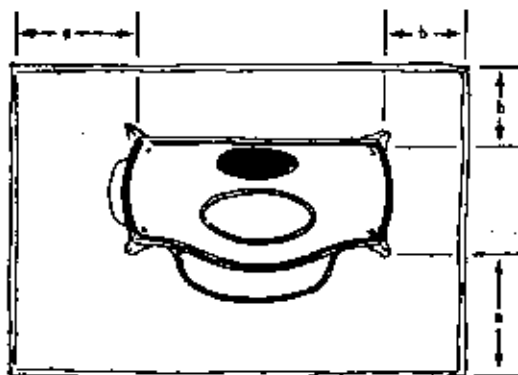

DEFIANT FLOOR PROTECTION
 a = 18" or 460 mm.
 b = 8" or 204 mm.

VERMONT CASTINGS STOVE-TO-FIREPLACE FLEX CONNECTOR SYSTEM

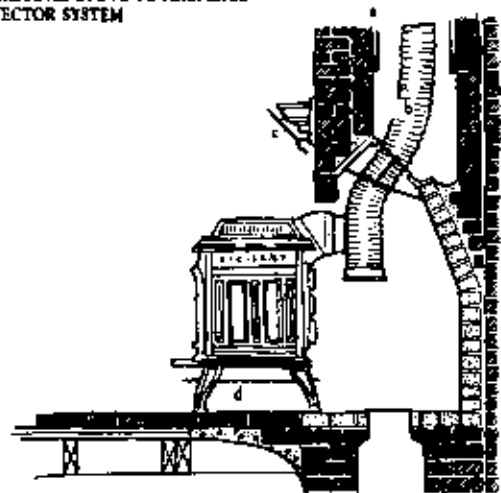

- a) Tile-lined masonry chimney built to or in compliance of National Building Code standards
- b) Vermont Castings Stove-to-FirePlace Flex Connector System
- c) Combustible masonry protected by custom fabricated heat shield—allows 18" (460 mm) clearance to stove top
- d) Bottom hear shield.
- e) Hearth extension to provide min. 18" (460 mm) floor protection from stove front load door and 8" from side of stove

Defiant Smoke Shelf

The Defiant Smoke Shelf is packed inside the stove for safe shipment. Before installing the stovepipe, insert the smoke shelf through the flue collar opening (damper handle must be pointing down) so that it rests in a horizontal position between the back of the stove and the fireback as shown.

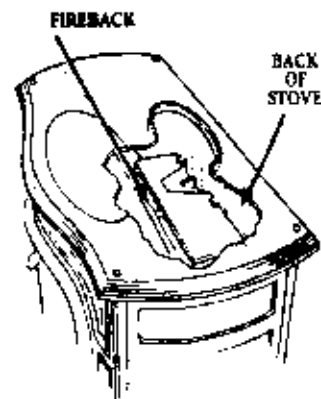

DEFIANT SMOKE SHELF POSITIONING

Resolute and Vigilant Ash Fettles

The ash fettle serves as a log and ash barrier at the base of the front door. It can be removed by pulling one end up and out; for the Vigilant pull upward on the RIGHT end, for the Resolute pull upward on the LEFT end.

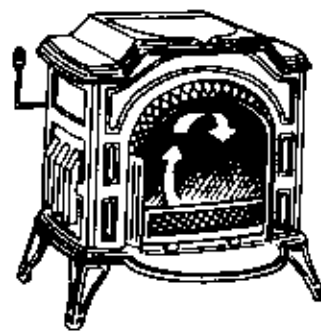

OPERATION

WARNING: To build the first fire in ignorance of or to disregard the information contained in this section can cause serious permanent damage to your stove, and void your warranty.

Cast iron, despite its superior characteristics as a material for wood stoves, must be treated with respect. It can be broken by a sharp blow from a hammer or from a large rapid temperature change. The cast iron in your new stove has been developed through testing in metallurgical laboratories and is among the best stove iron available: In composition it is not unlike the iron used long ago to create stoves that have endured a century or more of hard use. In the beginning it must be broken in like the old Model A. The break-in period is a small price to ensure the stove's longevity.

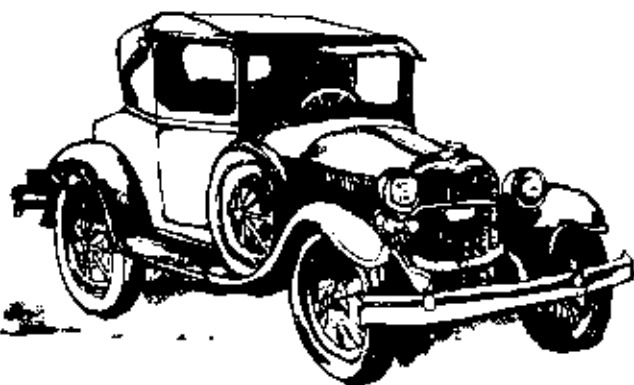

The First Fire

When your installation is complete, the chimney connector firmly in place and the bottom of the stove insulated with sand or ashes for Defiants or Resolutes, or refractory cement for Vigilants, you are ready to kindle your first fire. Set the damper in the updraft position, open the fireplace doors, and build a small fire using paper and dry kindling. Light the paper, securely latch the fireplace doors and loading doors (close the griddle in the case of the Vigilant and Resolute) and set the thermostat at the highest position. After a few minutes, when the fire has established a good draft in the flue, place two or three small logs (three inches to four inches in diameter) on the burning kindling.

After the logs have begun to burn strongly, the thermostat should be adjusted to keep a modest fire going in the updraft mode.

During these first fires, keep the combustion rate at a modest level and avoid a large updraft fire. Only after a dozen such fires, can you operate the stove at its maximum setting in the updraft mode, and then only if the iron has first been warmed. Remember this procedure even after your seasoning is complete. This warning applies to all cast iron stoves and can easily be summed up this way: **NEVER BUILD A ROARING FIRE IN A COLD STOVE.**

Never fire the stove so hot that any part begins to glow red. Damage to the stove, stovepipe and chimney can occur if the stove is overfired. Reduce the stove temperature by closing the air intake shutter in the event that overfiring should occur.

Daily Use

Kindle the fire in the same fashion as the break-in period. When the logs are burning well, (after about 30-45 minutes) close the damper. After a few minutes, when the fire has adjusted to burning in the side draft mode with the damper closed, turn the thermostat from the open position to the desired heat output setting. To refill the stove, open the damper and the loading door (or griddle on the Vigilant or Resolute), and fill the firebox. Allow the fire to burn long enough in updraft to establish the draft and to return to full heat output. Then close the damper. If the fire dies down completely after the damper has been closed, reopen it and allow the fire to burn more vigorously before reclosing the damper. Some drop-off in heat output is normal when the damper is first closed. Finally, adjust the thermostat for the heat output you desire. The stove will continue to produce even heat for many hours. Temperatures measured by placing a surface thermometer on the griddle of your stove can give an indication of your stove's performance. When first starting a fire, after re-fueling, or when enlivening the fire after a long burn, leave the damper open until the griddle reaches 260°C (500°F). Usual operating temperatures range from not lower than 150°C (302°F) to 370°C (698°F).

Remember: The stove is hot while in operation. Keep children, clothing and furniture away.

Fireplace Use

If the stove has been in use as a heater, and you wish to open the doors to view the fire, first open the damper. Then make certain that the magazine is not too full. The great amounts of air admitted when the doors are opened will cause the preheated logs in the magazine to burn quickly and hot. Fires should not be permitted to overheat, thus causing possible thermal stress to the iron. Check through the loading door or griddle and remove any wood or coals leaning against the front doors before opening them.

When the front doors are opened or removed, and the damper is open, the stove can be used like any other open fireplace. The thermostat and air controls have no function and require no adjustment. If you are only going to view the fire for a short period, you may wish just to open the doors. For longer periods you may want to remove them. The double doors on all four stoves are easily removed by lifting

them straight up. The door of the single door Resolute slides off to the left. **Caution:** If your stove has been operating the doors will be hot. Do not touch them unless you are wearing protective fireplaces gloves.

Open burning capability is a major feature of Vermont Castings stoves and we've tried to make it as practical and easy as possible. There is a generous ashlip to catch any sparks or coals that might fall out. The screen included with the stove rests solidly on the ash lip, and with all four stoves may be used with the doors either open or removed. Unless you are in the room, you should not leave your stove open and unattended. Always check first to make sure your screen is securely in place.

RECOMMENDATIONS

All stoves behave differently; even a single stove will react differently to different types of wood and chimneys. It will take time to accustom yourself to your new stove and to its responses to various conditions. Remember, our Customer Service Personnel or Authorized Dealers are always a phone call or letter away if you encounter a particularly perplexing problem.

Listed below are a number of ideas that will help you get the maximum benefits from your stove. The most exacting situation occurs when the stove is used around the clock as the primary heat source. Although these suggestions are aimed primarily at this usage, they should be helpful to all.

Do not add large amounts of fuel to a slow fire and leave the setting low. This may smother the fire. Adding large quantities of cold fuel to a slow fire is like asking an automobile to go up a hill in high gear from a standing start. The bigger the hill, the longer the running start you need. Allowing the fire to build up heat is the running start.

Firmly establish a strong fire before closing the damper and changing the stove to its side draft combustion mode. It only takes a short time, and the increased efficiency is well worth the trouble. A strong fire will increase turbulence, giving a better gas/oxygen mix and allowing flames to lick under the baffle, thereby assisting secondary combustion.

A good bed of coals is necessary to keep the volatiles hot as they leave the primary combustion chamber. When you want to shut the stove down before going to bed or leaving the house in the morning, try to let the temperature build up first. Ideally, you should load most of the wood thirty minutes before shutting the damper. Then, top off the magazine just before shutting down the stove and adjusting your thermostat. Your stove will burn cleaner and give you more heat if you follow these steps.

If you need more heat, remember that your stove is truly a combination stove and will operate either in an updraft or side draft combustion mode. In its horizontal configuration, only a limited amount of wood can actually become part of the primary fire mass at any given time. This obviously reduces the amount of heat generated. If in extremely bitter

weather you need more heat, simply switch to an updraft mode. All the wood in the magazine can now be incorporated into the primary fire mass, thus producing more heat. Keep in mind that the trade off made for this greatly increased output is increased wood consumption and shorter burn times.

Try to let the stove run fairly hot at least some of the time. If you find that your room seems too small to require high heat, try using the stove as a fireplace with the screen in position. A strong fire can be kept going at a high level with just a couple of sticks of wood and will not become too hot for the room. These practices will prevent too many deposits from building up inside the magazine. Large accumulations of black flaky deposits inside the magazine are a sign that the stove would be happier at higher temperatures and should occasionally be run in updraft.

When we designed these stoves we had in mind a handsome cast iron heater and fireplace unit. Although they will consume any combustible material, we do not really think of them as trash incinerators. Excessive amounts of paper and greasy or plastic materials may burn too hot, ignite a chimney fire, or create a rapid build-up of ash. When using the stove to dispose of waste materials, treat it with common sense and respect and be aware of what the stove was designed to do.

Wood: The drier the better. It takes heat to boil off the water in a piece of green wood. (There can be over a ton of it in a cord of green wood, or more than 250 gallons.) This lost heat is not recoverable and lowers internal temperatures, reducing the likelihood of secondary combustion. Split lengths of dense hardwoods should be dried under cover for at least eight months, though a year is preferable.

Wood grows outward from the center in a series of concentric cylinders or rings. When wood dries, water moves in the spaces between the cylinders ten times faster than it does across or through the cylinder walls. This means that unsplit wood dries only through the ends of the logs. Large and long logs should be split to expose the spaces between the rings in order to aid the drying process. It really does not help too much to cut the wood and let it dry for a summer and then split it just before use.

Wood should not be cut too small, as this speeds up the gasification process and causes it to burn too quickly. If you are having trouble getting the stove to hold a fire for as long as you would like, perhaps your wood is too small. Anything over twelve inches long and four inches measured across the end of the log will do. The stoves work well with as large a piece of wood as can be fit in. Irregular shapes with stubs of branches that hold the logs apart are not good, and rotten wood is the worst. Burning and rotting are similar chemically; so, in effect, rotten wood is partially consumed and has already given up some, if not most, of its heat value.

Under no circumstances should a piece of wood with ice or snow on it ever be put into any stove. The sudden thermal shock can crack the iron. Leaning an ice-covered piece against the stove to melt the ice is also likely to cause damage. We do not warrant our stoves against such abuse.

MAINTENANCE

ASH REMOVAL

During constant use, ashes should be removed every few days, or when they have built up around the air distribution ports to noticeably affect operation. This is easily done when the stove has died down with only a log or so left, as in the morning.

To empty the ashes, a few shovel scoops is all that is required. They may be taken from any door which allows good access, even with a log or two still left within the firebox.

In order to achieve the high efficiencies which side draft combustion offers, it is necessary to burn the primary fire mass in as compact and hot a manner as possible. Burning logs lying directly on a good bed of hot coals, which in turn are insulated from the cooling iron of the bottom, is the best way to do this. Grates with relatively cool air circulating underneath, tend to disperse the high temperatures required by allowing coals to fall from the fire zone. Grates make it more difficult to control oxygen flow to the fire mass.

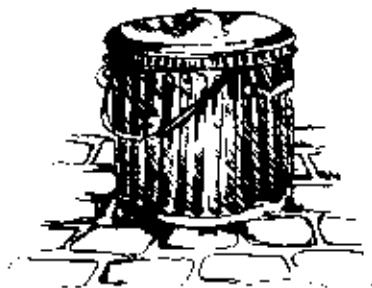

CHIMNEY CLEANING

A wood-fired heating system requires maintenance of the whole system. Inspection of the chimney and flues should be performed prior to every heating season and twice monthly while the stove is in use. The flaky, crusty lining of creosote deposits must be removed periodically. We recommend you clean your chimney whenever inspection reveals the build-up of creosote. Because this build-up is governed by the type of wood burned, the manner in which you burn it, and the characteristics of the chimney itself, there are no hard and fast rules as to how the chimney should be cleaned. Generally speaking, outside chimneys will require more cleaning more often. Large flue sizes will require more attention than smaller ones. Check the safety of your chimney during each inspection and repair or replace damaged or worn chimney parts when necessary.

If you clean your chimneys yourself, proper cleaning tools and safety equipment are essential. If you are at all unsure of your ability to do the job, we strongly recommend that you hire a trained chimney sweep.

STOVE CLEANING

Some creosote production often occurs in air-controlled stoves like the Defiant, Vigilant, Resolute and Intrepid precisely because they are such efficient heat transfer devices. You must learn to watch for creosote, to control it, and to get rid of it.

Improperly seasoned wood and excessive operation with low, smoldering fires are two major causes of creosote production. Choosing the proper size stove for the space to be heated is your best defense against creosote.

If the stove is oversized for its heating area, it will not have the opportunity to burn at a sufficiently high combustion rate. As mentioned earlier, the lower end burning rates are less efficient, therefore more chimney deposits will be formed. A smaller stove operating at a higher burn rate will give better heat distribution, control and efficiencies than a larger stove burning at too low a setting.

NOTE: In the event that you should have a chimney fire, close all the doors, the damper and the air intake shutter. Then call your local fire department for help.

Some creosote deposits in the firebox of a side draft combustion burner are normal and require no attention as they burn off when the stove is used as a fireplace or in updraft configuration. During each heating season it is a good idea to remove the chimney connector periodically and inspect the stovepipe and chimney for abnormal build-up. At this time it is also a good idea to touch the vacuum cleaner nozzle to each distribution port and to the air inlets.

With a normal draft—unless the ashes in the firebox have been allowed to build up too high around the ports—these ports will be self-cleaning and require only an annual check.

NEW STOVES

New stoves should be carefully checked within the first month of service.

- Be sure leg bolts are snug.
- New gasketing may compress quickly at first. Handle adjustment may be necessary.
- Inspect chimney connector and flue for signs of creosote build-up. Rapid accumulation of deposits in the stove or chimney system may indicate a need for changes in stove operation.
- Inspect the whole chimney system to ensure all joints are secure and tight.
- Check to see that glass panels or cast iron panels in doors are secure. Snug up retaining screws if necessary.

MAINTENANCE GUIDELINES

Since each stove, installation and operation has its' own individual characteristics, no maintenance schedule can apply to all situations. These suggestions can serve as guidelines while you develop your maintenance program.

| | STOVE | CHIMNEY & CHIMNEY CONNECTOR |
|------------|--|---|
| DAILY | <ul style="list-style-type: none"> • Check the ash level in the bottom of the stove. Clear the primary air ports in the fireback and left side of the stove if they are blocked. Restrictions to the flow of combustion air may result in a slow, inefficient burn. • Be sure Air Inlet Shutter moves freely as you adjust the thermostat lever. • Clean the area around your stove and be sure all tools and equipment are readily available. |  |
| TWO WEEKS | <ul style="list-style-type: none"> • Clean the glass panes in doors if necessary. Be sure glass is cool. Wipe up spills immediately. | |
| TWO MONTHS | <ul style="list-style-type: none"> • Check to be sure doors are closing securely. Gasketing becomes compressed over time. Handle adjustment may be necessary. Preventing air from leaking into your stove will help in giving you close control over the burn rate. | <ul style="list-style-type: none"> • Clean chimney connector, giving extra attention to elbows and horizontal runs. • Inspect chimney connector. |
| YEARLY | <ul style="list-style-type: none"> • Thoroughly clean stove interior. • Check that all controls work freely. • Remove chimney connector and clean baffle system between fireback and back of stove. • Replace gasketing and firebricks (Intrepid only) as needed. • Remove ashes from bottom of stove and place a drying agent in the stove to absorb moisture from the air. • Clean dust off all heat shields. • Check stove seams, and re-cement if necessary. • Re-paint the stove. • Lubricate handle shafts. | <ul style="list-style-type: none"> • Thoroughly brush the chimney and connector to remove all ash. • Inspect the chimney and chimney connector for any signs of deterioration. Have a professional mason repair the chimney. Replace chimney connector sections if any appear to be corroded. |

INTREPID MAINTENANCE

Under normal firing conditions, soot or fly ash may accumulate in the bottom of the secondary combustion chamber. These deposits should be removed periodically to insure proper air flow through the stove. Clean the chamber when you clean your chimney flue and stovepipe. We suggest you inspect the chamber once per month until you determine how quickly build-up occurs.

Access to the secondary combustion chamber is gained from the inside of the stove with removal of the upper fireback. Loosen the two 5/8" acorn nuts on the outside of the back plate. The fireback weld screws can then be turned and the fireback removed. Disengage the damper from the damper rod and remove the two vertical firebricks. **Be Certain The Stove Is Completely Cold Before Removing Ashes.**

When you replace the two vertical firebricks, be sure they are positioned as shown.

Engage the damper with the damper rod and set the damper flat on the firebricks. Tilt the upper fireback into position, keeping the brick retainer bar behind the front firebrick. As you push the upper fireback against the rear plate of the stove, the back edge of the damper must be above the stop on the back of the stove.

Turn the weld screws back over the fireback tabs and retighten the acorn nuts on the back of the stove only until snug.

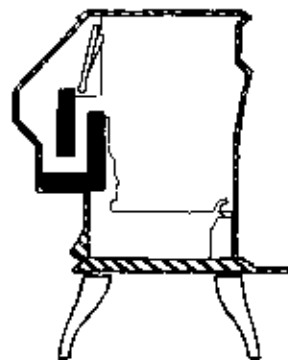

CORRECT FIREBRICK PLACEMENT - CROSS SECTION.

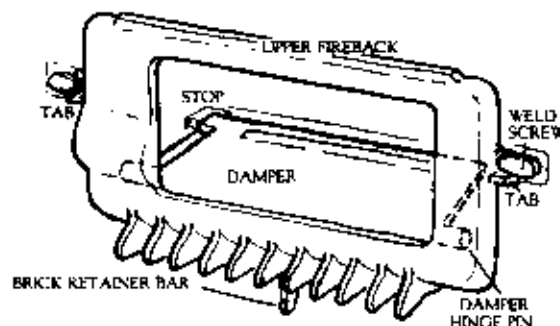

DETAIL OF THE UPPER FIREBACK

HANDLES & LATCHES

The insert handle is designed so that you will always have a cool handle with which to operate your stove. Extra ceramic parts and bolts are available in case of damage to the assembled handle.

The door latches were carefully designed to permit easy adjustment, ensuring an airtight fit over the years. We have included a 1/8-inch Allen wrench to help you. After a period of time the gasketing may compress and you will want to tighten the latch mechanism. Loosen the small locking nut on the striker screw. Tighten the screw a turn or two with the small Allen wrench. Tighten the screw a turn or two with the small Allen wrench, and retighten the locking nut. The large locking nut holds the pawl on the shaft and should not require any adjustment.

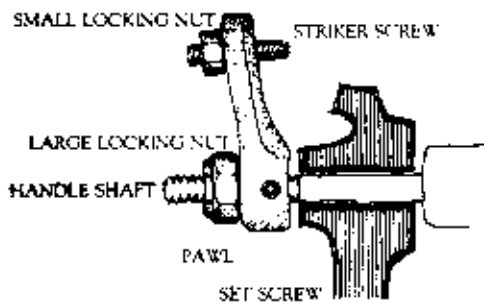

A large Allen wrench (5/32 inches) is included in the Defiant and Vigilant to allow you to tighten the damper handle should it work loose after extended use.

GASKETS

Gaskets in good condition provide a seal around the doors and griddle opening of the stove. If over a period of time you notice that the gaskets have become worn or frayed they should be replaced with Vermont Castings brand gaskets.

GLASS DOORS

Depending upon the mode of burning and rate of burn, carbon deposits may form on the inside of the glass. Hot, updraft fires help keep glass clean, while slow side draft fires are likely to cause soot to form. It is important that the glass be completely cooled as any cleaning agent applied to hot glass may permanently etch it. Once the glass is cool, any common glass cleaner will do the job. Remove all traces of cleaner and dry the glass before firing the stove. If the glass is ever damaged, replace it immediately with Vermont Castings high temperature glass which is specially designed for safe stove operation.

Some glass cleaning agents may discolor porcelain enamel surfaces, so wipe any spills immediately.



QUESTIONS & ANSWERS

The stove does not hold a fire as long as you would like:

Check the thermostat adjustment. When the stove is warm (too hot to touch, but not overly hot) move the thermostat lever to its lowest setting. Does the *Inlet Air Shutter* close? If not, then adjust the ball chain at the bottom down a ball or two and try again.

Perhaps your wood is too small in diameter or too short, as was mentioned earlier, and the charge is just burning too quickly. Burning soft woods such as pine will significantly reduce the burn time because they will combust at a more rapid rate than hardwood. Maximum burn time is achieved by burning hard wood cut to proper length.

Did you remember to close the damper and adjust the thermostat? It is very easy to forget these two things.

Check the gasketing. Perhaps a piece of charcoal has dislodged or compressed the gasketing so that the door has lost its seal. In time the door latches will need to be tightened.

It is possible (though it happens rarely) that you have excessive draft. This usually occurs with a tall interior masonry chimney that is located so that prevailing breezes constantly blow across the top, as in the case of a house located high on a hill or near the shore. Should this prove to be the case, first experiment with closing down the secondary air control slightly. Easy does it here. A 30 percent closing is probably all that it will require. In extreme cases, try installing a flue damper to partially restrict the draft.

The stove smokes as a fireplace:

Chimney deposits may have built up in the stovepipe or chimney and are restricting the draft. Remove the pipe and clean. Is there another stove or heating device on the same flue? An oil furnace is open vented and the draft may be pulling air from the basement rather than through the stove. If your stove is connected to a chimney with a fireplace on the same flue, make sure the fireplace dampers are closed or the opening blocked off to ensure a strong draft.

How tight is your house? Sometimes new homes are constructed and insulated so effectively that a sufficient volume of oxygen is not available for the burning process. Try opening a window a crack. If this solves your problem, then you know your house is too tight and outside air will have to be introduced.

In moderate weather establish a strong fire with the front doors closed, then open the front doors to the fireplace mode. This will prime the chimney to maximize the draft.

Back Puffing:

In the spring you will notice your draft is less strong. If you experience back puffing during unusual weather conditions, this usually means that you have temporarily lost the chimney draft. To regain a positive draft open the damper and adjust the thermostat to the open position. This condition can be prevented by closing the secondary air control and leaving the stove on updraft. Cold weather back puffing usually is a result of gusts of wind and can be partially avoided by the use of a chimney cap.

STOVE DIMENSIONS

The following elevations provide dimensions which will enable you to plan your installation as accurately as possible. Be sure to plan your stove placement so that top-loading access is not restricted in the Vigilant, Resolute, and Intrepid.

Defiant

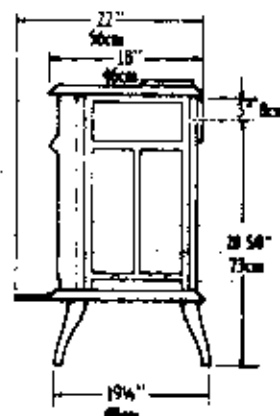
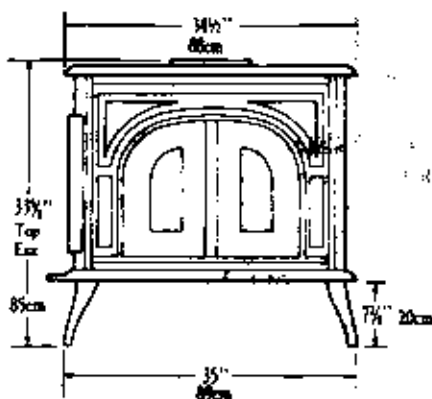

Vigilant

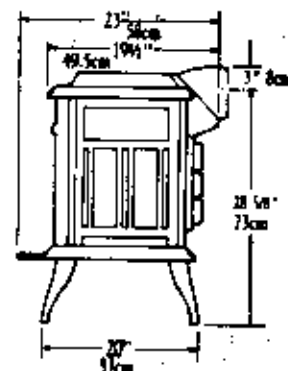
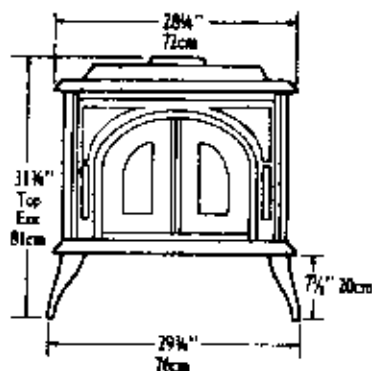

Resolute

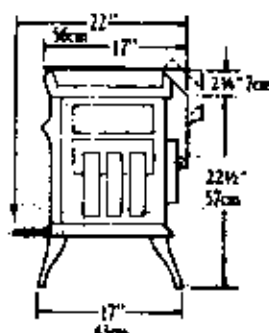
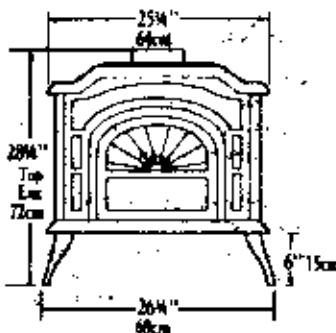

Intrepid

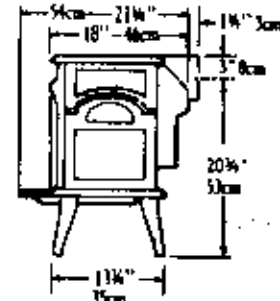
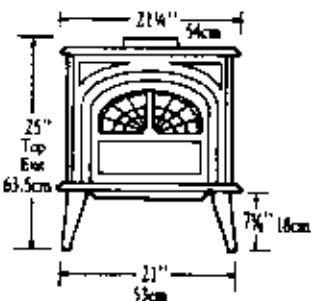

Short legs reduce the height of the Intrepid by 4" - 10cm

WARRANTY - FOR USE IN CANADA LIMITED 3 YEAR WARRANTY

Vermont Castings, Inc. warrants that your stove will be free of defects in materials and workmanship for a period of three years from the date received except that the catalyst, thermostat assembly, handles, glass door panels, gasketing, coal grates, coal linkages, and coal magazine throat which are subject to normal wear and tear shall be warranted as described below.

Vermont Castings, Inc. will repair or replace, at its option, any part found to be defective when the stove is returned with shipping charges prepaid to an authorized Vermont Castings service center. If upon inspection the defect is found to be the fault of the manufacturer, repairs will be authorized at no charge to the customer for parts, and/or labor.

Any stove or stove part, other than the catalyst, that is repaired or replaced during the limited warranty will be warranted for a period not to exceed the remaining term of the original limited warranty or six (6) months, whichever is longer.

LIMITED 1 YEAR WARRANTY

Parts subject to normal wear & use.

Parts of the stove which are subject to normal wear and tear are warranted to be free of defects in material and workmanship for a period of one year from the date you receive it. These parts are the thermostat assembly, handles, glass door panels, gasketing, coal grates, coal linkages, and the coal magazine throat. Any of these items found to be defective will be repaired or replaced at no charge, upon the return of said part to an authorized Vermont Castings service center with postage prepaid.

CATALYST WARRANTY

(For Defiant Encore™ only)

The catalyst, which is subject to normal wear and tear, will be warranted for a six year period as follows:
If the original catalyst or a replacement catalyst proves defective within 24 months from the date the stove is received, the catalyst will be replaced free. From 25-72 months a pro-rated credit will be allowed against a replacement catalyst. The purchaser will be liable for the difference in cost between the credit and the retail price of the catalyst at the time of replacement.

| AMOUNT OF TIME SINCE PURCHASE | CREDIT TOWARD REPLACEMENT COST |
|----------------------------------|-----------------------------------|
| 0-24 months | 100% |
| 25-36 months | 50% |
| 37-48 months | 30% |
| 49-60 months | 20% |
| 61-72 months | 10% |

Any replacement catalyst will be warranted under the terms of the catalyst warranty for the remaining term of the original warranty. The purchaser must provide the following information in order to receive a replacement catalyst under the terms of this limited warranty.

1. Name, address and telephone number
 2. Proof of original purchase date.
 3. Date of failure of catalyst
 4. Any relevant information or circumstances regarding determination of failure.
- In addition, the owner must return the failed catalyst.

EXCLUSIONS AND LIMITATIONS

1. The warranty is transferable. However, proof of original retail purchase is required.
2. This warranty does not cover damage resulting from overfiring the stove. Overfiring will result if the stove is used in such a manner as to cause one or more of the stove plates to glow red. Overfiring can later be identified by warped plates and areas where the paint pigment has burned off. Overfiring in enamel stoves is identified by bubbling, cracking, chipping, and discoloration of the porcelain enamel finish.
3. This warranty does not cover misuse of the stove as described in the Operation Manual, nor does it cover a stove which has been modified unless authorized by a Vermont Castings representative in writing.
4. Porcelain enamel parts are subject to bubbling, chipping, cracking, crazing and discoloration when subjected to abnormally high temperatures or thermal shock. Vermont Castings offers no warranty on porcelain enamel surfaces subjected to these conditions.
5. Damage to stove while in transit is not covered by this warranty but is subject to a claim against the carrier. (Do not burn the stove as this may negate the claim with the carrier.)
6. Claims are not valid where installation does not conform to local building and fire codes or, in their absence, to the recommendations in our Operation Manual.
7. Vermont Castings shall have no obligation to enhance or update any unit once manufactured. IN NO EVENT SHALL VERMONT CASTINGS BE LIABLE FOR INCIDENTAL AND CONSEQUENTIAL DAMAGES. ALL IMPLIED WARRANTIES, INCLUDING THE IMPLIED WARRANTIES OF MERCHANTABILITY AND FITNESS ARE LIMITED TO THE DURATION OF THIS WRITTEN WARRANTY. NO ORAL OR OTHER WRITTEN WARRANTY IS ENFORCEABLE.

HOW TO OBTAIN SERVICE

If a defect is noted within the warranty period, the purchaser should contact the nearest Vermont Castings Authorized Dealer with the following information:

1. Name, address and telephone number of purchaser.
2. Date of delivery, and place of purchase.
3. Serial number from the back of the stove.
4. Nature of defect or damage.
5. Any relevant information or circumstances, i.e. insulation, mode of operation when defect was noted.

Vermont Castings reserves the right to withhold final approval of a warranty claim pending a visual inspection of the defect by authorized representatives.



We are proud of our stoves and proud of the heritage of cast iron stoves which have warmed so many Vermont farm houses over so many generations. We have tried to maintain that tradition while furthering the art of home heating. The design of our stoves, inspired by the architectural history that surrounds us in these small northern communities, depicts the Federal period of the early 19th century, the same period which contributed so many of the graceful churches that overlook our town greens.

Should you have any questions on the use and maintenance of your stove, please contact your local Vermont Castings Authorized Dealer. He will continue to provide assistance and advice to you for as long as you own your Vermont Castings stove.

Finally we would like to hear your thoughts and suggestions. We recognize that the purchase of a wood or coal burning stove is a serious investment, one that warrants careful consideration and the comparison of other stoves with ours. We hope in your search you found, as we did, the need for stoves like the Defiant, the Vigilant, the Resolute and the Intrepid long overdue.

The Defiant®, Vigilant®, Resolute® and Intrepid® have been tested to Underwriters' Laboratory of Canada (ULC) Standard 627-1979. Important information such as the serial number of the stove is located on a metal plate affixed to the back of the stove. For additional installation information, consult the Canadian Standards Association (CSA) Bulletin D-92.

MANUFACTURER'S LIMITED WARRANTY: Your Vermont Castings Parlor Stove is carefully inspected before leaving the factory, and is guaranteed to be free of defect in material or workmanship for three years. However, those parts that come in contact with the coal fire shall be warranted for one year. We will repair or correct any parts found to be defective when returned to us at our designated warranty station. You must pay shipping charges. This Warranty does not cover damage caused by abuse, improper use contrary to instructions set forth in our Operation Manual, overfiring, normal wear and tear, or damage incurred in transit. See your Warranty Registration Card for a full copy of the terms of our warranty coverage.

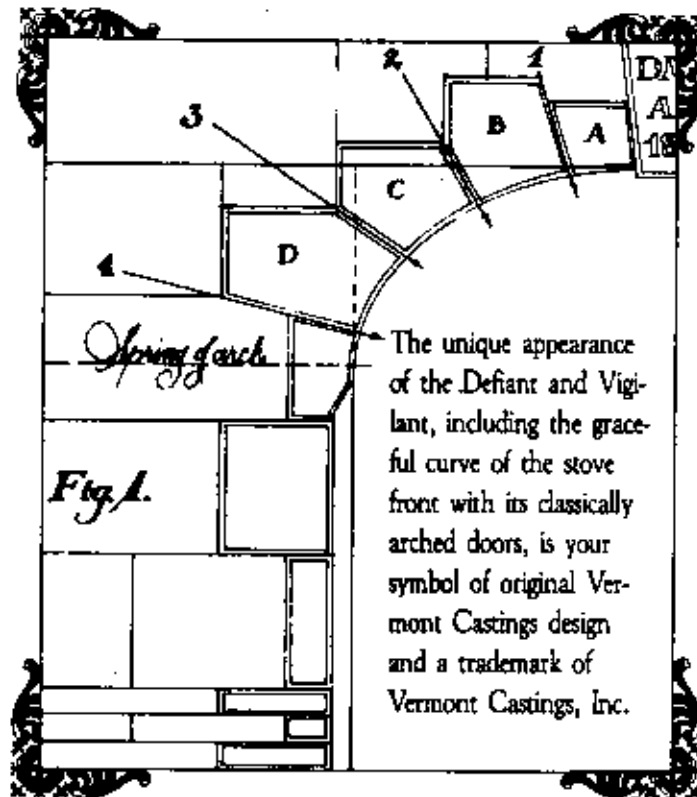

VERMONT CASTINGS, INC.®
 Prince Street, Randolph, Vermont 05060