

Scan 59



Congratulations on your new Scan wood-burning stove

You have purchased a product by one of Europe's leading manufacturer's of wood-burning stoves, and we are sure that you will have years of pleasure with your purchase. To make the best possible use of your stove, it is important that you follow our advice and instructions.

Please read this Assembly- and instructions manual before you start to assemble your stove.

123456

Make a note of your stove's product registration number here so that you have it available if you need to contact us.

**Test in compliance with
EN 13240**



Version GB 09.12.08 - 1

Table of contents

Installation	3
Installation	
Approval	
Technical data and dimensions	
Dimension sketch Scan 59	
Assembly	4
Type plate	
Product registration number	
Service package	
Accessories	
Positioning your wood-burning stove	
Position near to non-flammable walls	
Distance to flammable walls	
Distance to furniture	
Load bearing underlay	
Floor plate	
Connection between stove and steel chimney	
Requirements for chimney	
Connection with 90° elbow pipe	
Adjusting screws	
Flue collar top outlet	
Preparing the stove for a rear outlet	
Fresh air intake	
Closed combustion system	
Instruction for use	9
CB Technology	
Primary air	
Secondary air	
Smoke deflector plates	
Ash pan	
Handle for riddling grate	
Instructions for heating	10
Lighting	
Handling fuels	
Maintenance	11
Troubleshooting	12

Installation

The house owner is responsible for ensuring that all necessary national and local safety measures are observed during installation and fitting and also responsible for observing the fitting and operating instructions detailed in this manual.

When you install any kind of fireplace or stove, you must inform the local authorities. You are also responsible for calling in a chimney sweep to inspect and authorize the installation.

To ensure best-possible functionality and safety for your installation, we advise you to call a professional fitter. Our Scan Dealer will be able to recommend a qualified fitter in your area. For information on Scan Dealers, please go to www.scan.dk.

Approval

If you intend to connect your stove to an existing chimney, it makes sense to contact an authorised Scan dealer, or a local chimney sweep for advice. These experts will also let you know if your flue needs renovating.

On connecting to a multiple element chimney: follow the vendor's instructions as applicable to the chimney type (e.g. Leca, Plewa, Icopal, Isokern, Zanda etc.)

No matter whether an authorised Scan dealer installs your stove, or you do the job yourself, remember that the chimney sweep has to approve the installation before you start to use it.

Technical data and dimensions

CO Emission at 13% O ₂ :	0,11%	1430 mg/Nm ³
Dust @ 13% O ₂ :		20 mg/Nm ³
No _x @ 13% O ₂ :		101 mg/Nm ³
Efficiency:		74%
Rated heat load:		5,5 kW
Chimney temperature:		340 °C
Flue outlet flow:		6,5 g/sec
Recommended vacuum in flue collar:		16 Pa
Combustion air requirement:		18,6 Nm ³ /h
Recommended fuel:		Wood
Fuel consumption:		1,9 Kg/h
Amount of fuel:		1,5 kg
Weight:		109 kg
Flue collar internal diameter:		135 mm
Flue collar external diameter:		148 mm
Approval type:		Intermittent fuelling

Intermittent fuelling means normal use of a woodstove. In other words, you should let the fire die down until only the embers are left, before refuelling.

The Scan 59 was build in compliance with the homologized product type specified in the Assembly- and Instructions Manual provided with the product.

Dimension sketch Scan 59

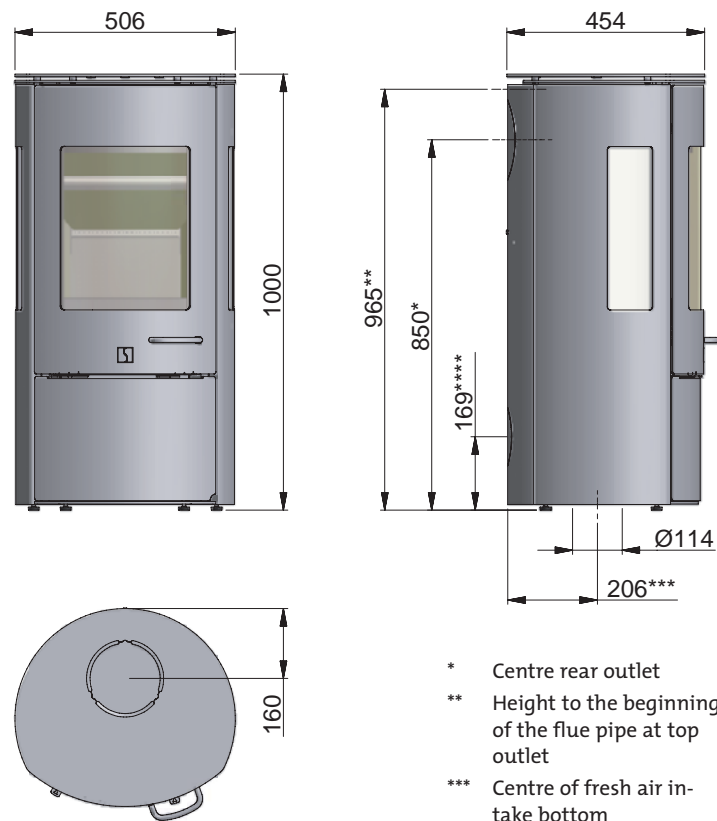

- * Centre rear outlet
- ** Height to the beginning of the flue pipe at top outlet
- *** Centre of fresh air intake bottom
- **** Centre of fresh air intake rear

Type plate

All Scan wood-burning stoves are fitted with a type plate, that specifies the approval standards and the distance to flammable materials.

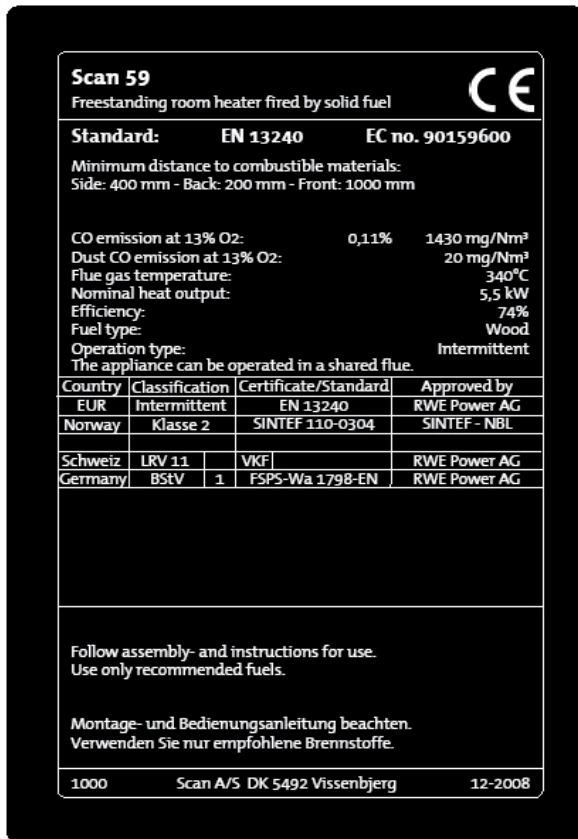

Product registration number

Open the wood-burning stove door; you can read and make a note of the product registration number (see front of these Assembly- and instructions for use).

Product registration number

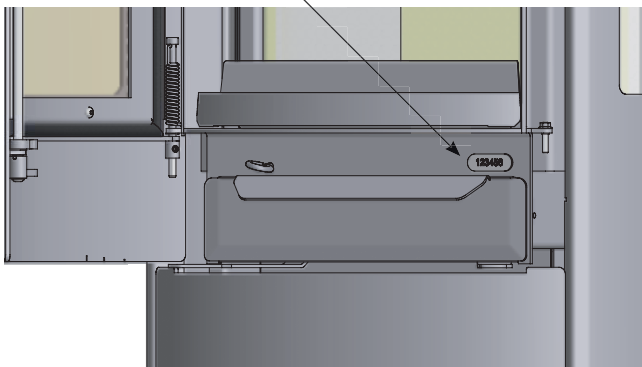

Service package

The service package contains the following:

- Fitting for flue collar
- Seal
- Safety fitting
- Plastic plugs for transport safety hole at the bottom of the stove
- Various tools
- Glove
- Fire starters for first lighting

Accessories

- Large shaped floor plate in glass or steel.
- Small shaped floor plate in glass or steel.
- Soapstone top plate for top outlet
- Soapstone top plate for rear outlet

Soapstone top plate for Scan 59 with top outlet

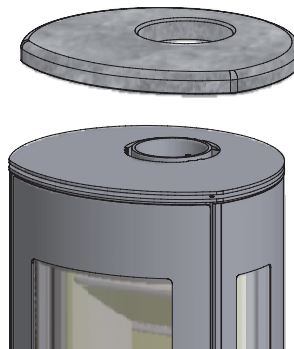

Soapstone top plate for Scan 59 with rear outlet

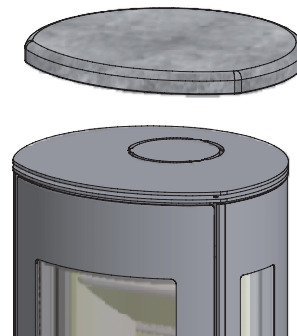

Placering af brændeovn

Positioning your wood-burning stove

The wood-burning stove must be set up so that the stove itself, the flue pipe, and the chimney can all be cleaned.

Position near to non-flammable walls

When positioning near a non-flammable wall, we recommend you keep a minimum distance of 50 mm between the rear of the product and the wall for cleaning purposes.

Distance to flammable walls

Parallel rear wall installation

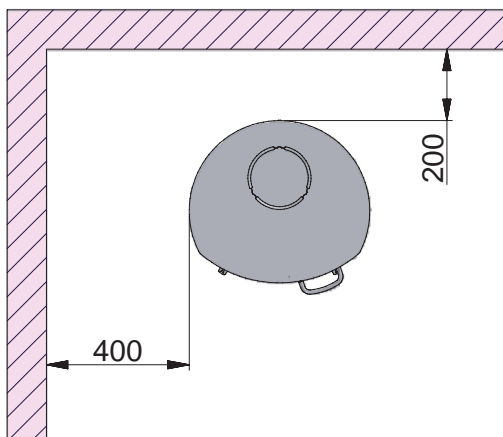

45° Corner installation

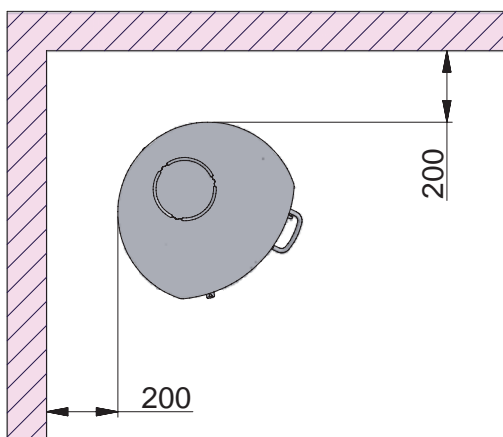

Distance to furniture: 1000 mm

But please check to avoid furniture or other furnishings being dried out due to being too close to the stove.

Load bearing underlay

All of the products in our portfolio are classified as light-duty fireplaces; in most cases, there is no need to reinforce the floor, so that you can typically use the normal floor.

However, you should make sure that the load bearing underlay can bear the weight of the wood-burning stove and that of the chimney.

Floor plate

If you are setting up the stove on a flammable floor, observe national and local regulations on the size of the non-flammable underlay that covers the floor around the stove.

Your local Scan dealer can advise you on regulations concerning flammable materials in the vicinity of your stove.

The idea behind the floor plate is that it protects the floor and flammable material against sparks.

The floor plate can be made of steel or glass, and the stove can be set up on brick, natural stone or similar materials.

This Scan wood-burning stove has an integrated floor plate, and can thus be set up on any flammable material without a protective underlay.

Small shaped floor plate for the Scan 59

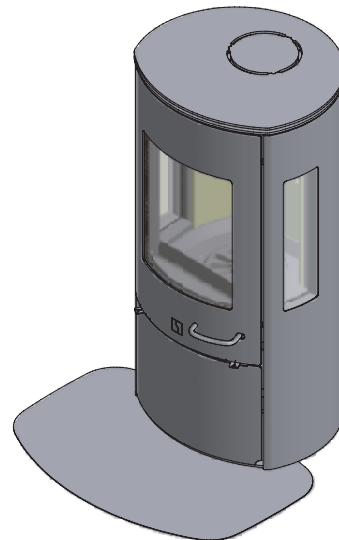

Large shaped floor plate for the Scan 59

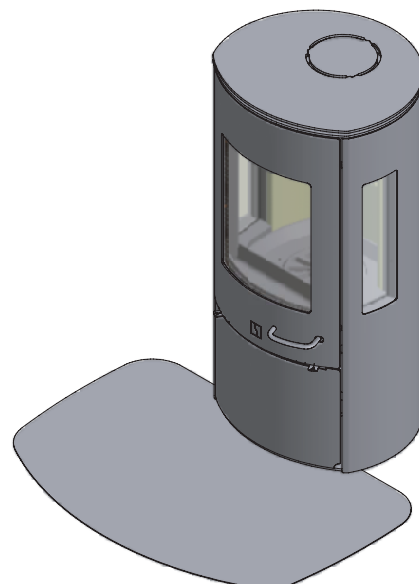

Connection between stove and steel chimney

Your Scan dealer, or local chimney sweep, can advise you on choosing a make and type of steel chimney. This ensures that the chimney will match your wood-burning stove. As a general rule, the length of the flue should not be less than 3,5 m measured from the top of the wood-burning stove.

Choosing the wrong length or diameter of steel chimney could impair functionality.

Always observe the chimney vendor's instructions precisely.

Requirements for chimney

The chimney must be labelled T400 and G for soot testing.

Connection with 90° elbow pipe

If you intend to use an elbow pipe with the Scan 59, we recommend the use of a curved elbow pipe to improve the draft.

The cleansing lid on the elbow pipe must be located in the vertical section of the pipe to allow cleaning of the horizontal section through the access cover.

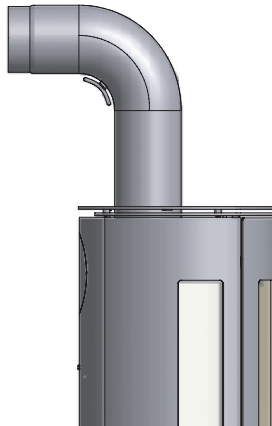

Adjustment screws

The Scan 59 has four adjustment screws under the wood-burning stove. Use the adjustment screws to get the stove to stand vertically.

Tilt the wood-burning stove and adjust the adjustment screws. You may also choose to adjust the adjustment screws from the space beneath the combustion chamber, using the accompanying key from the service pack.

If you are using a shaped floor plate, you should adjust the stove upwards to allow the plate to be inserted under the front of the stove.

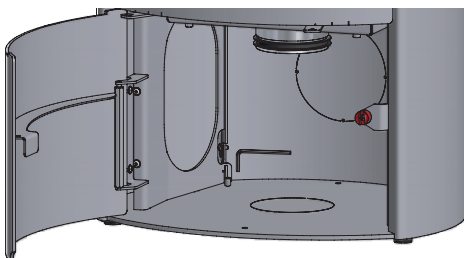
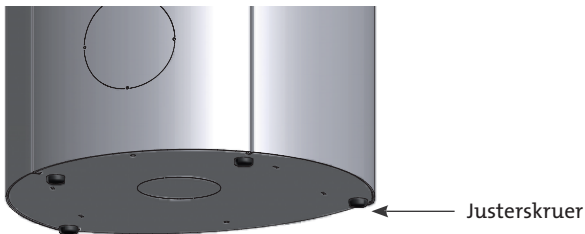

Flue collar top outlet

Your wood-burning stove has been prepared for a top outlet by the manufacturer. Remove the cover plate from the top plate, and fit the flue collar, the enclosed seal, and the fittings from the service package. At the same time, fix the safety fitting crosswise to prevent damage to the smoke deflector plate when sweeping the chimney.

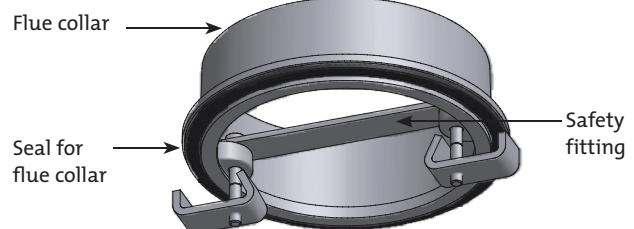
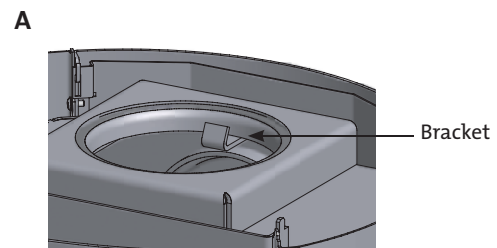
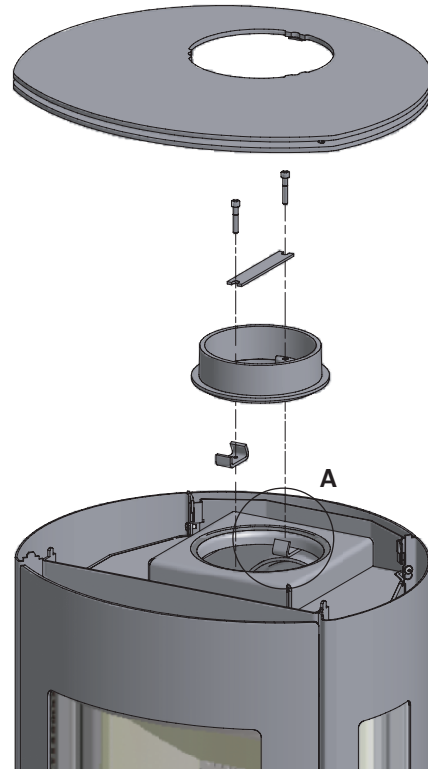

Preparing the stove for a rear outlet

1. To attach the flue pipe, remove the cover plate on the rear plate and heat shield as follows:

Drill out the four holes in the cover plates with a $\varnothing 8$ bit and remove the plates.

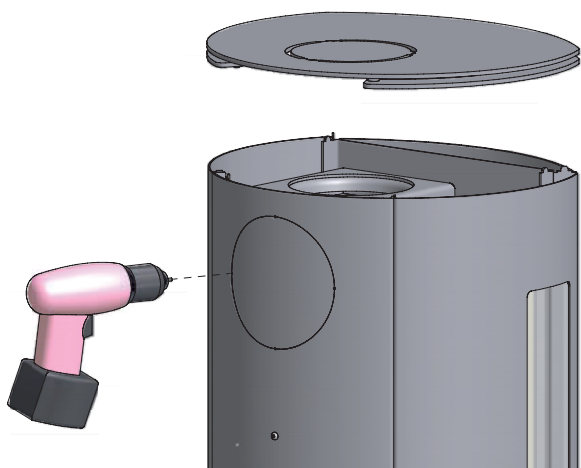

2. Undo and remove the blanking plate from the inside. This is to be used later as a seal and cover at the top of the smoke outlet.

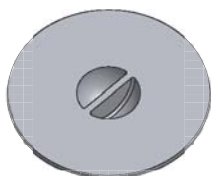

3. Fit the separate flue collar in place from the outside and fix in place using the bracket and seal supplied in the service pack.

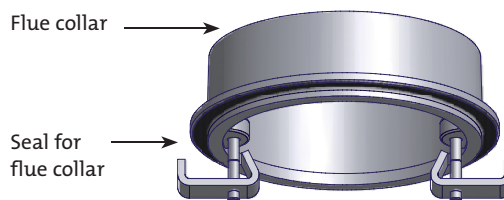
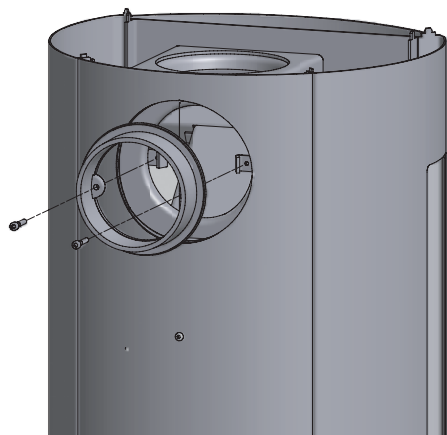

4. Fit the blanking plate in the smoke outlet. Place the top plate on the stove.

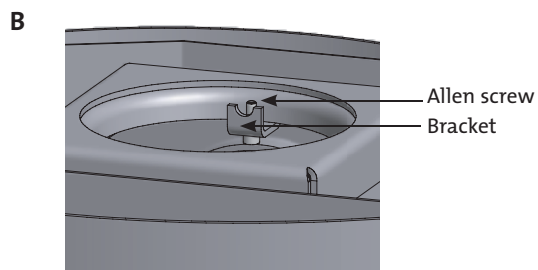
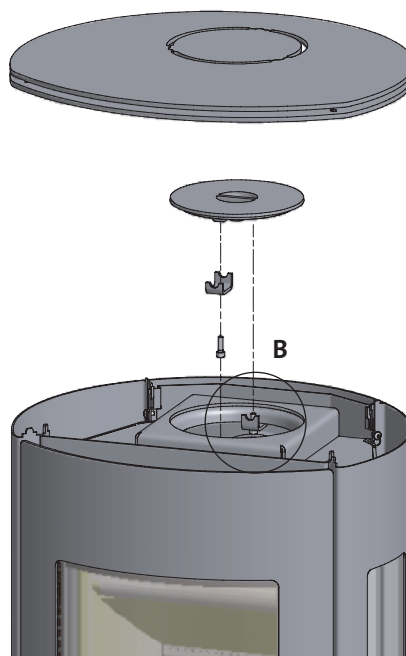

Fresh air intake

In a well-insulated house, the air used up by the burning process has to be replaced. This particularly applies to houses with mechanical ventilation. There are different ways of making sure that an air exchange takes place. The most important thing is to ensure that there is a supply of air to the room where the wood stove is located. The external wall vent must be located as close to the wood stove as possible, and you must be able to close it when you are not using the wood stove.

National and local building regulations must be followed with regard to the connection of fresh-air intake.

Closed combustion system

You should use the closed combustion system for the wood-burning stove if you live in a newly-built, airtight home. Outside air for combustion is connected through a ventilation pipe via the wall or floor.

It must not be possible to shut off the ventilation pipe with a valve

- Minimum $\varnothing 100$ mm ventilation pipe, maximum length: 6 m with a maximum of one bend

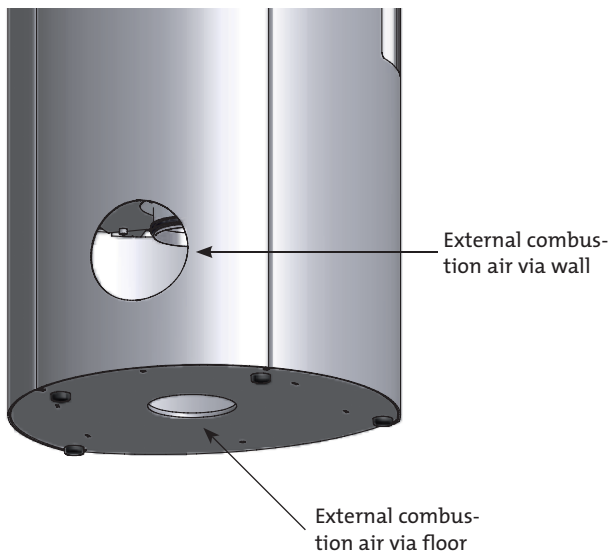

Outside air for combustion is supplied through the floor

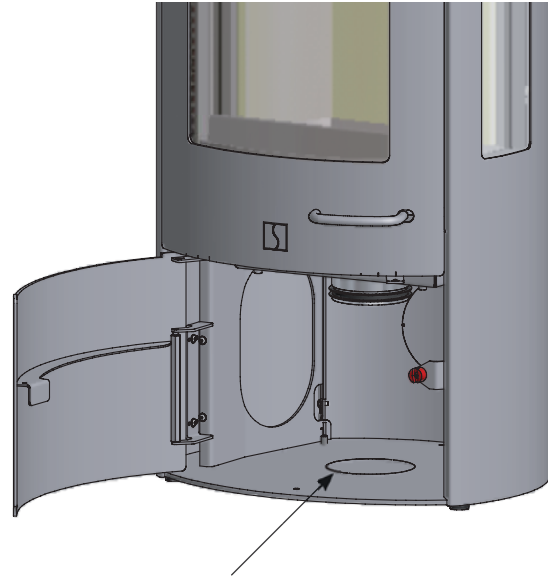

The cover plate at the bottom of the wood-burning stove is removed and outside air is connected to the connection piece underneath the combustion chamber.

Outside air for combustion is supplied through the wall

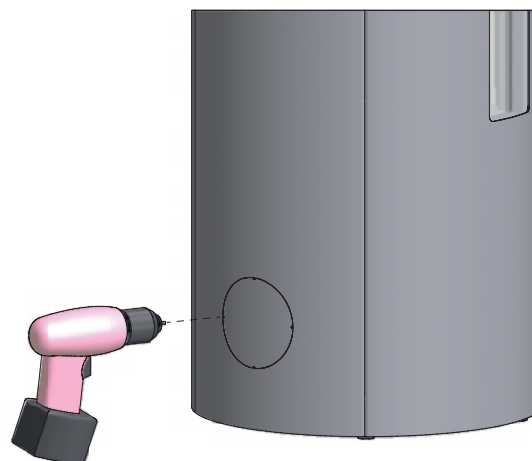

Drill out the four holes in the cover plate with a $\varnothing 8$ bit and remove the plate.

Connect outside air to the connection piece underneath the combustion chamber.

CB Technology (Clean Burning)

Your wood-burning stove is fitted with CB technology. To ensure optimum burning of the gases released by the burning process, air is guided by a specially developed system. Pre-heated air is fed into the combustion chamber through the small holes below the smoke deflector plate. The airflow is driven by the combustion speed, and cannot be regulated.

Primary air

The primary air regulation mechanism is used for lighting the fire, or to boost the burning process when you put wood on. The primary air vent can be 0-30% open if you use hard wood fuel such as oak and beech. You can close the primary air vent if you use soft wood such as birch or pine for fuel.

Settings for normal load: 0 - 30%

Secondary air

Secondary air is pre-heated and fed indirectly to the fire. At the same time, the secondary airflow cleans the glass pane to avoid soot build-up. If you over-restrict the secondary airflow, soot can build up on the glass pane. The secondary airflow determines the heat output from your wood stove.

Settings for normal load: 50 - 70%

Smoke deflector plates

The smoke deflector plates are located in the upper part of the combustion chamber. The plates hold back smoke, making sure it stays inside the combustion chamber for a longer time before escaping through the chimney. This reduces the smoke gas temperature as the gases have more time to dissipate heat to the wood-burning stove. The smoke deflector plates must be removed for sweeping; see „Maintaining your wood-burning stove“. Note that the smoke deflector plates are made of porous, ceramic material, and can break. Exercise care when working. The smoke deflector plates are subject to wear and tear, and are not covered by the warranty.

Ash pan

Open the glass door to access the ash pan which is located below the combustion chamber.

Keep the ash pan closed at all times when the wood stove is lit.

Handle for riddling grate

Your wood stove is fitted with a riddling grate which empties the ash from the combustion chamber into the ash pan when activated.

The riddling grate must be in semi-open position while the wood stove is lit.

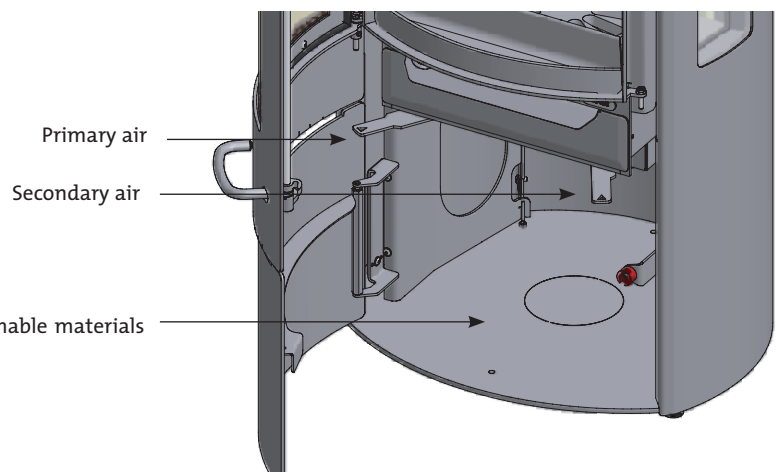
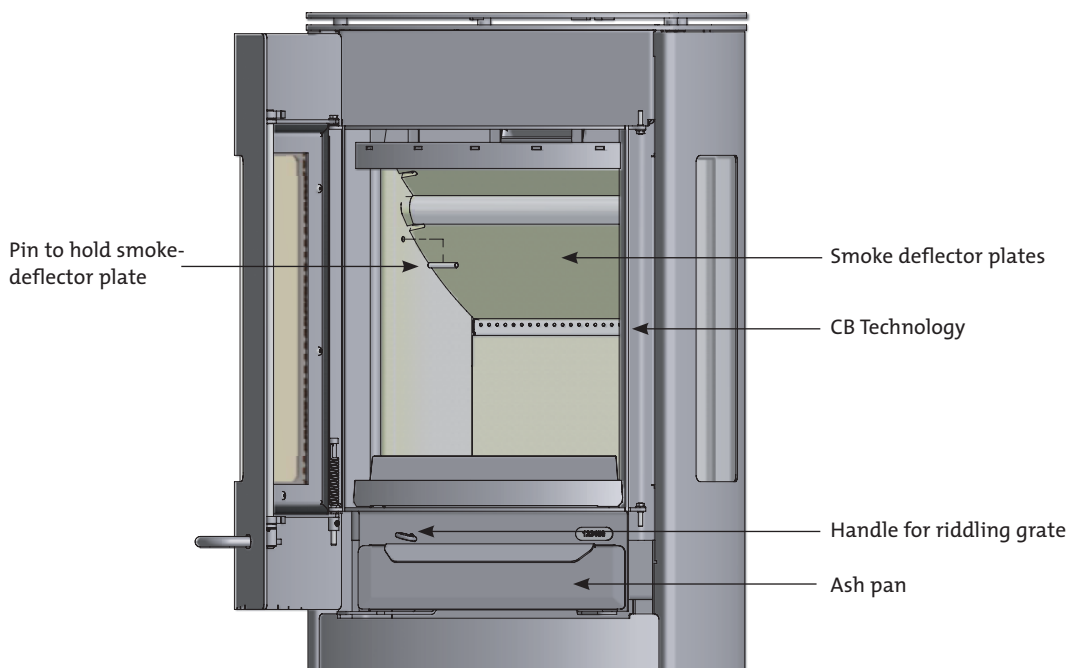

For security reasons it is not allowed to store flammable materials under the combustion chamber of the Scan 59.

Environmentally-Friendly Heating

Avoid restricting your wood-burning stove to an extent where no flames are visible during the degasifying period, as this leads to particularly inefficient heating. The gases released by the wood do not burn due to the low temperature in the combustion chamber. Part of the gas condenses in the wood-burning stove and flue system as soot, and this could lead to your chimney catching fire. The smoke that exits the chimney is bad for the environment and has an unpleasant smell.

Lighting

We recommend the use of fire starters, or similar products, which are available from your Scan dealer. Using fire starters helps to light the wood quicker, and keeps the burning process clean. Never use liquid lighting fuels!

„Top down“ lighting

2-3 pieces of wood approx. 25 cm long with a weight of approx. 0.4 – 0.6 kg per piece.

1 piece of wood approx. 20 cm long with a weight of about 0.5 kg.

8 - 16 thin sticks of about 20 cm with a total weight of approx. 400 g.

3 fire starters.

Position the large logs in the centre of the combustion chamber 1-2 cm apart as shown. Put half the kindling sticks across the logs in a criss-cross fashion. Place the smallest log on top of the sticks as shown and arrange the last sticks in front of the log. Position the firestarters between the sticks and light.

Set the primary and secondary airflow controls to maximum for about 20 - 30 minutes. When the larger pieces of wood have caught fire properly, you can set the primary and secondary airflow to the desired level.

"Top down" lighting gives a more environmentally friendly start to your fire and helps to keep the glass areas as clean as possible.

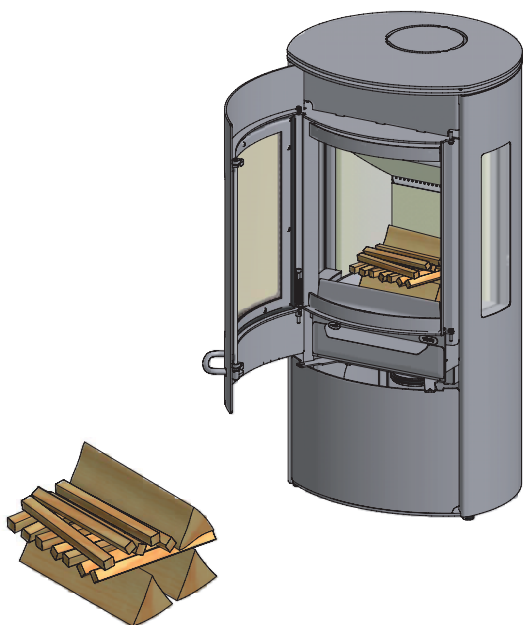

Continuous firing

It is important to reach as high a temperature as possible in the combustion chamber. This makes the most efficient use of the wood stove and fuel, and ensures a clean burning process. At the same time, this avoids soot build-up on the combustion chamber walls and glass. While the stove is lit, you should not see any smoke, but just air movement that indicates the burning process.

After completing the lighting phase, you should have a good layer of embers in the wood stove; you can then start stoking up the stove. Lay 2-3 pieces of wood, of about 0.4 - 0.6 kg weight with a length of about 25 cm onto the fire.

Note! The wood must catch fire quickly; this is why we recommend setting the primary airflow to full power. Running the stove at too low a temperature and with too little primary air can lead to deflagration of the gases, and thus cause damage to the stove.

When stoking up with wood, always open the glass door carefully to avoid smoke escaping. Stoke up with wood while the fire is still burning nicely.

Using your stove in the spring or autumn

Occasional lighting of the stove using the „top down“ lighting method (see above) is recommended in changeable weather such as in spring/autumn when your heating requirements are not as great.

Why you need a chimney

The chimney is the wood-burning stove's motor; its performance decides how well your stove will work. The draft in the chimney creates a vacuum in the wood-burning stove. The vacuum draws the smoke out of the stove, and takes in air through the combustion air baffle to fuel the burning process. Combustion air is also used for the airwash system that keeps the window clear of soot.

The draft in the chimney is caused by the difference in temperatures inside and outside the chimney. The higher the temperature difference is, the better the draft in the chimney will be. It is thus important for the chimney to reach operating temperature before you adjust the damper to restrict combustion in the stove (a brickwork chimney will take longer to reach operating temperature than a steel chimney). It is very important to reach operating temperature as quickly as possible on days on which the draft in the chimney is poor due to unfavorable wind and weather conditions. Make sure the fuel ignites as quickly as possible (with visible flames). Chop the wood into particularly small pieces; use an extra fire lighter etc.

After longer periods of disuse, check the chimney flue for blockage. You can connect several units to the same chimney. But make sure check with your chimney sweep to observe local regulations.

No matter how good your chimney is, it will not perform well if you do not use it correctly. On the other hand a poor chimney, may give you acceptable results if you use it correctly.

Using your stove in various weather conditions

Wind blowing on the chimney can have a great effect on how your stove reacts in various wind conditions; you may need to adjust the airflow to achieve good burning results. Fitting a damper in the flue pipe may also help as it will give you the ability to regulate the draught in changing wind conditions.

Fog can also have a great influence on how well a chimney draws; you may again need to adjust the airflow settings to achieve good burning results.

Stove with glass panes on three sides

The Scan 59 with side panes has a "glass-cleaning channel" that conducts secondary air downwards across all three glass panes of the combustion chamber. This airflow acts as a curtain of air providing some protection against the glass panes getting dirty. It is however unavoidable that such a large area of glass will get dirty. This is not due to any defect with the stove.

General Notes

Your wood stove is not designed for continual heating for periods of over 24 hours.

Please note! Parts of the wood-burning stove, especially the outer surfaces, become hot during use. Please exercise due care.

Never empty ashes into a flammable container. Ashes can contain glowing embers long after you finish using your wood stove.

While the stove is not in use you can close the baffle to avoid drafts through the stove.

After longer breaks you should check the smoke outlet paths for blockages before lighting.

Chimney fires

In case of a chimney fire, keep the stove door, the ash drawer, and all the valves on the stove closed. In case of emergency, call the fire service.

Handling fuels

Selecting Wood/Fuel

You can use any type of wood as firewood, however, harder types, such as beech, ash, are generally better for heating as they burn more evenly and create less ash. Other wood types like maple, birch and spruce are excellent alternatives.

Handling

Firewood is best if you fell the tree, and saw and split the wood, before May 1st. Remember to cut the logs to match the size of your wood-burning stove's combustion chamber. We recommend a diameter of 6-10 cm. The length should be about 6 cm shorter than that of the combustion chamber to leave enough space for air to circulate. Firewood with a greater diameter needs splitting. Split wood dries faster.

Storing

You need to store the sawn and split firewood in a dry place for 1-2 years before burning. Wood dries faster if you stack it in an airy place. Before use, store the firewood for a few days at room temperature. Note that wood absorbs moisture during the autumn and winter seasons.

Moisture

To avoid environmental issues, and for optimum burning, wood has to be perfectly dry to be suitable for use as firewood. The max. residual moisture in the wood should not exceed 21%. A moisture content of 15-18% yields best results. As an easy way of checking if wood is dry, just knock two pieces of wood together. If the wood is moist, the sound will be dull.

If you use damp wood, most of the heat it produces will be used to evaporate the water. The temperature in the wood stove does not rise, and the room is not sufficiently heated. Of course, this is not economical, and it will cause soot build up on the glass pane, in the stove, and in the chimney. Burning moist wood also causes pollution.

Understanding units for measuring wood

Various units of measurement are used for wood. Before you buy wood, it makes sense to familiarise yourself with the terms. There are various brochures, in public libraries for example, that cover this topic.

Use of the following as fuel is illegal

Painted, pressure impregnated, or glued wood, driftwood from the sea. Never burn chipboard, plastics, or chemically treated paper. These materials are dangerous to humans, to the environment, your wood stove, and your chimney. To keep a long story short – make sure you burn only quality firewood.

Firewood fuel value

The fuel value is different for different types of wood. In other words, you need to use more wood of certain types to achieve the same heating performance. This Instruction Manual assumes that you will be using beech, which has a very high fuel value, and is also a wood that is easy to procure. If you use oak or beech wood fuel, note that these wood types have a greater fuel value than, say, birch. Make sure you use less fuel to avoid damage to the wood-burning stove.

Wood types	Kg Dry wood/m ³	Compared to beech
Hornbeam	640	110%
Beech/Oak	580	100%
Ash	570	98%
Maple	540	93%
Birch	510	88%
Pine	480	83%
Fir	390	67%
Poplar	380	65%

Maintaining your wood-burning stove

Apart from regular chimney sweeping, your wood-burning stove does not require any regular maintenance.

Coated surfaces

Clean your wood-burning stove by dusting with a dry, lint-free cloth.

If the topcoat is damaged, you can purchase a repair spray from your authorised Scan dealer. As slight differences in colour are possible, spray a larger area to achieve a natural transition for best results. For best results, apply repair spray when the wood-burning stove is hand-hot.

Cleaning the glass

Our wood-burning stoves are designed to prevent serious soot build up on the glass. The best way to achieve this is to make sure you have a sufficient combustion air supply. It is also important to use dry wood, and have a correctly dimensioned chimney.

Even if you follow all of our instructions, a slight film of soot can build up on the glass. You can easily remove this build up by cleaning with a dry cloth and glass cleaner. Your authorised Scan dealer stocks a special glass cleaner for this purpose.

Combustion chamber lining

Slight cracks can appear in the combustion chamber lining due to moisture, or to the heating/cooling process. These cracks have no influence on the heating performance or lifetime of your stove. However, if the lining starts to crumble, you must replace it. The combustion chamber lining is not covered by the warranty.

Seals

All wood-burning stoves have seals made of ceramic material fitted to the stove, the doors, and/or the glass. These seals are subject to wear and tear, and must be replaced when necessary.

Chimney sweeping and cleaning your wood-burning stove

Follow national and local chimney sweeping regulations. We recommend having the wood-burning stove cleaned regularly by the chimney sweep.

Before starting to clean your wood-burning stove, and sweep the flue pipe, we recommend first removing the smoke deflector plates.

Use only original replacement parts for maintenance and repairs of your stove.

Note! Make sure the stove is cold before starting maintenance or repair work.

Removing the smoke deflector plates

Be very careful when removing the smoke deflector plates from the stove.

Lift the lower smoke deflector plate, remove the pins at the sides, and then remove the plate. Remove the upper smoke deflector plate in the same way.

Smoke escaping

- Damp wood
- Chimney not drawing properly
- Chimney is not properly dimensioned for the stove
- Check if the smoke gas pipe/chimney are blocked
- Is the chimney the right height for its surroundings?
- At rear outlet, check that the flue pipe does not obstruct the chimney draught
- Vacuum in room
- The door is opened before the embers have burned down sufficiently

Wood burning too quickly

- The air valves are set incorrectly
- The smoke deflector plates is incorrectly mounted or missing
- Inferior firewood (waste wood, pallets etc.)
- Chimney too large

Soot build-up on glass

- Incorrect secondary airflow setting
- Excessive primary air
- Damp wood
- Wood pieces too large on lighting
- Inferior firewood (waste wood, pallets etc.)
- Chimney not drawing sufficiently
- Vacuum in room

Excessive soot build-up in chimney

- Poor burning (more air required)
- Damp wood

The surface of the stove is turning grey

- Overheating (see instructions for heating)

Poor heating performance of stove

- Damp wood
- Not enough wood
- Inferior wood quality with low fuel value
- Smoke deflector plates are not fitted correctly

Odour and sound coming from the stove

- The lacquer on the stove hardens when you use the stove for the first time; this can cause an odour. Open a window or a door for ventilation, and make sure the stove is heated up sufficiently to avoid odours later.
- When heating up and cooling down, the stove may make some clicking noises. These are due to the huge temperature differences to which the material is exposed and do not indicate any product defects.

Warranty

All wood-fired Scan products are made of high-quality materials and subject to strict quality controls before leaving the factory. We give a warranty of 5 years on manufacturing errors or defects.

You must quote your stove's product registration number when you contact us or your authorised Scan dealer with a warranty claim.

The warranty covers all parts which in the opinion of Scan A/S require repair or replacement due to manufacturing or construction error

The warranty applies to the original purchaser of the product only, and is not transferable (except on prior sale).

The warranty covers only damage caused by manufacturing or construction errors.

The following parts are not covered by the warranty

- Wear and tear parts, such as the combustion chamber liners, smoke deflector plates, shaker grate, glass, tiles, and seals (except for defects which were present on delivery).
- Defects caused by external chemical and physical influences during transportation, storage and assembly, or at a later time.
- Soot build-up caused by poor chimney draught, damp wood, or improper use.
- Costs of additional heating in connection with a repair.
- Transport costs.
- Costs for setting up, removing the wood stove.

This warranty is void

- In case of incorrect installation (the installer is responsible for observing and complying with legal requirements and local bylaws, along with this Assembly- and Instructions manual for the wood-burning stove and accessories).
- In case of improper use, and/or use of prohibited fuels, non-original spares (see this Assembly- and instructions manual).
- If the product registration number of the stove has been removed or damaged.
- In case of repairs that do not comply with our instructions or instructions by an authorised Scan dealer.
- In case of any manipulation of the original state of this Scan product or its accessories.
- This warranty is only valid in the country to which this Scan product was originally supplied.

Always use original replacement parts, or parts recommended by the manufacturer.