

# PARKRAY

THE FIRST NAME IN SOLID FUEL

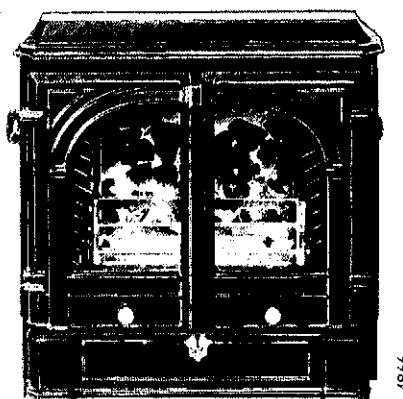
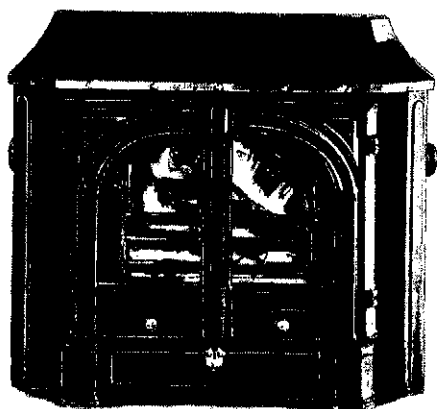

## PARKRAY CHILTERN and CUMBRIA

### *Instructions for Use*



Approved for solid mineral fuel by HETAS Ltd.

**PARKRAY LTD** The Britannia Suite, St. James Buildings, 79 Oxford St., Manchester M1 6FR  
Telephone: **0870 240 7376** Fax: **0870 240 7310**  
Email: [info@parkray.co.uk](mailto:info@parkray.co.uk) Website: [www.parkray.co.uk](http://www.parkray.co.uk)

# **IMPORTANT**

**TO ENSURE LONG AND SAFE OPERATION OF YOUR APPLIANCE PARTICULAR ATTENTION SHOULD BE GIVEN TO THE FOLLOWING ITEMS AT ALL TIMES.**

**CHIMNEY CHECKS.....PAGE 5**

**ASH CLEARANCE.....PAGE 8**

**SMELL OF FUMES.....PAGE 9 and 14**

**FLUE CLEANING.....PAGE 11 and 15**

**CHIMNEY SWEEPING.....PAGE 12 and 16**

**THIS APPLIANCE SHOULD NOT, UNDER ANY CIRCUMSTANCES BE RUN FOR ANY PERIOD OF TIME WITH THE FIREDOOR OPEN.**

## THE PARKRAY CHILTERN AND CUMBRIA - INSTRUCTIONS FOR USE.

To make sure of long and SAFE operation of your roomheater particular attention should be given to items asterisked \* below.

CONTENTS	PAGE
<b>GET TO KNOW YOUR ROOMHEATER .....</b>	4
<b>WARNINGS .....</b>	5
<b>A. OPERATING INSTRUCTIONS - SOLID MINERAL FUELS .....</b>	6
A1 Fuels .....	6
A2 Firelighting* .....	6
A3 Controls .....	8
A4 Stoking .....	8
A5 De-ashing* .....	8
A6 Ash Clearance* .....	9
A7 Overnight Burning .....	9
<b>A. OPERATING SECURITY .....</b>	9
A8 Fire Blazing out of Control .....	9
A9 Smell of Fumes or Fuel will not burn * .....	9
A10 Bottomgrate bars distorting or failing prematurely .....	10
<b>A. ROUTINE BUT ESSENTIAL SAFETY PROCEDURE .....</b>	11
A11 Flue Cleaning* .....	11
A12 Chimney Sweeping* .....	12
A13 Periodical Shutting Down .....	12
<b>B. OPERATING INSTRUCTIONS WOOD AND BITUMINOUS COAL BURNING.....</b>	13
B1 Fuels* .....	13
B2 Firelighting*.....	13
B3 Controls .....	13
B4 Stoking .....	13
B5 De-ashing* .....	14
B6 Ash Clearance*.....	14
B7 Overnight Burning.....	14
<b>B. OPERATING SECURITY .....</b>	14
B8 Fire Blazing out of Control .....	14
B9 Smell of Fumes or Fuel will Not Burn .....	14
<b>B. ROUTINE BUT ESSENTIAL SAFETY PROCEDURE .....</b>	15
B10 Flue Cleaning* .....	15
B11 Chimney Sweeping* .....	16
B12 Periodical Shutting Down.....	16
<b>C. CARE AND CLEANING - All Fuels .....</b>	17
C1 Glass Door.....	17
C2 Enamel and Paint Finish .....	17
C3 Internal metal parts .....	17
C4 Brass decoration .....	17
C5 Bottomgrate bars.....	17
<b>D. WATER SYSTEMS (Except 36) - All Fuels .....</b>	17
D1 Balancing the System .....	17
D2 Poor hot water supply when radiators are on .....	17
D3 Water heating system frozen* .....	17
<b>E. SHORT LIST OF SPARE PARTS .....</b>	18

# CHILTERN ILLUSTRATED

4867

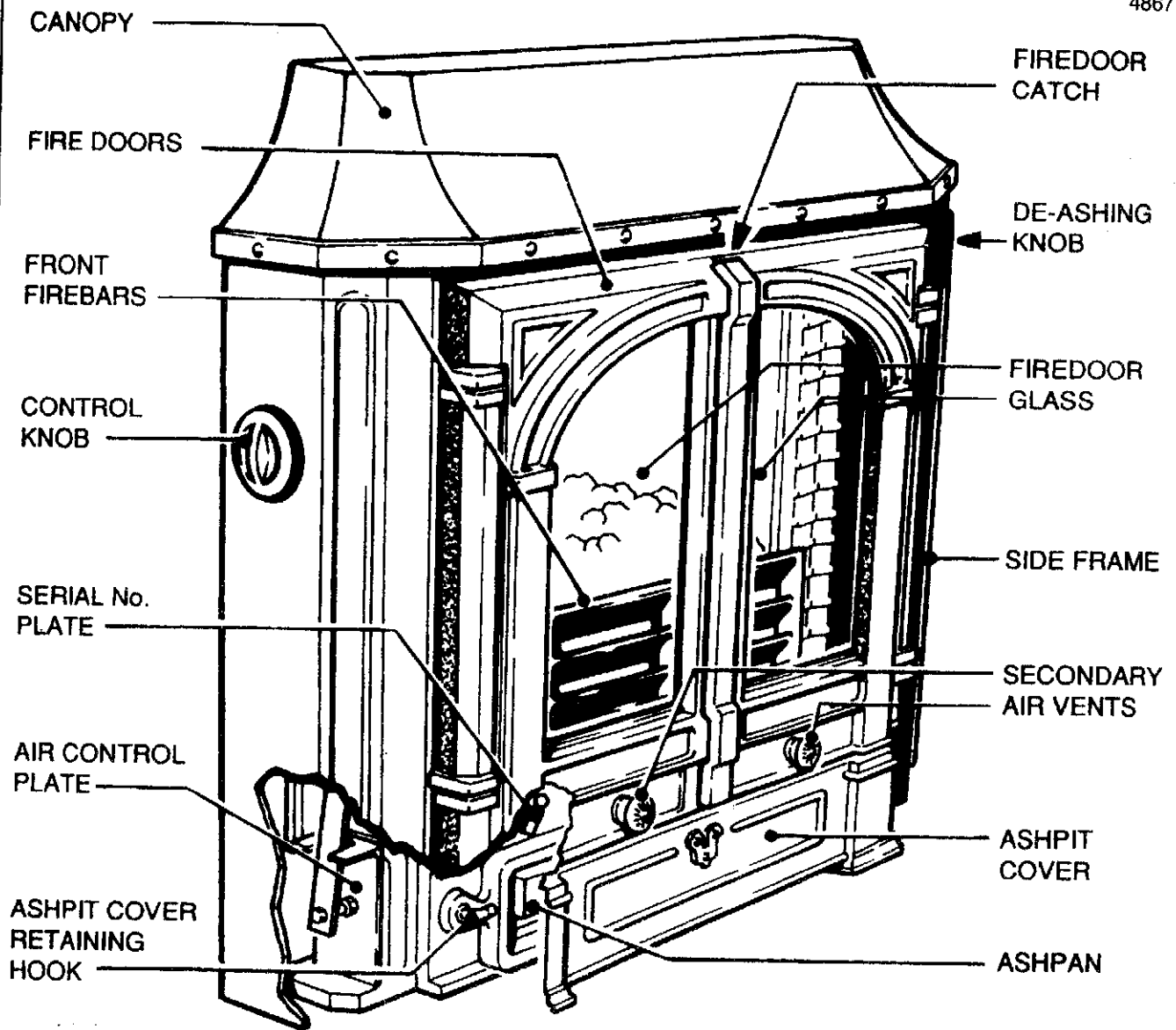

**Always use the operating tool for handling the throatplate, firedoors, firedoor catch, shaker knob, ashpit cover and for carrying the ashpan.**



Approved for solid mineral fuel by HETAS Ltd.

# CHILTERN

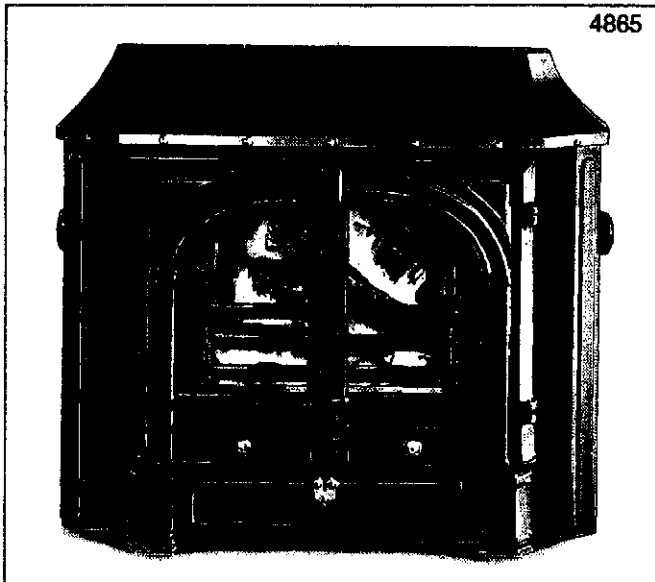

# CUMBRIA

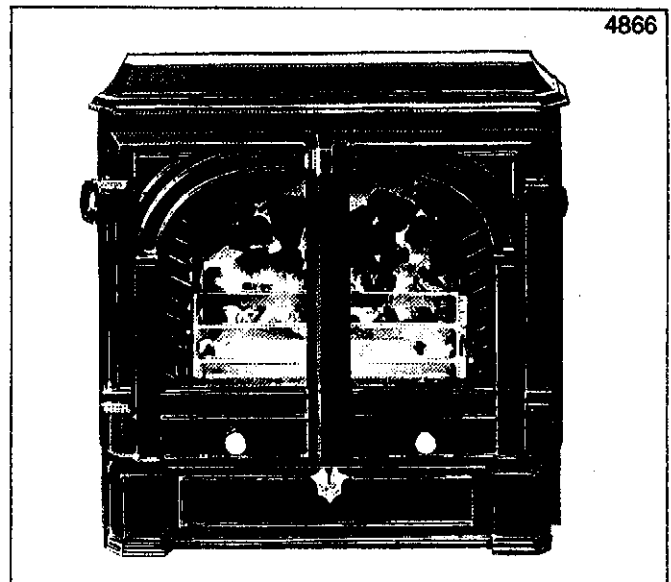

## IMPORTANT WARNING

Check the chimney:

\* is sound and has no cracks or other faults which might allow fumes into the house.  
Older premises especially may have chimney faults.

\* has been swept clean immediately before installation.

It should be emphasised that where the chimney is believed to have served an open flue installation it is possible that the higher flue gas temperature from a closed roomheater may loosen deposits that were previously firmly adhered, with the consequent risk of flue blockage. It is therefore recommended that the chimney be swept a second time after one month of regular use.

Attention is drawn to Section A11, A12, B10 and B11 regarding the cleaning of the throat plate and chimney.

### Air Supply

It is essential that the roomheater has adequate air supply for combustion and ventilation. Apertures provided for this purpose shall not be restricted.

### Water Heating System Frozen (Not applicable to 36 Model).

The fire must not be lit if there is any possibility that parts of the water system may be frozen.

### Appliance Doors.

This appliance SHOULD NOT under any circumstances be run for any period of time with the doors open when burning Solid Mineral Fuel or bituminous coal.

### Fireguard

Where children the elderly or the infirm are likely to be in the presence of your roomheater a fireguard to the current issue of British Standard 6539 "Fireguards for use with solid fuel appliances" should be fitted.

### Aerosol Sprays

Do not use aerosol sprays near a working roomheater.

### Extractor Fans

Extractor Fans must not be fitted in the room in which your roomheater has been installed as to do so may result in the flue pull being reversed causing fume emission into the room.

### Gas Burner

During lighting if the gas burner is found to have gone out. **TURN OFF THE GAS. DO NOT** attempt to relight for at least 15 minutes.

### Cleaning and Servicing

**WARNING.** When cleaning or servicing this fire care should be taken when handling metal parts and glass door to avoid the possibility of personal injury.

**HOW TO ACHIEVE THE BEST PERFORMANCE WITH HIGH EFFICIENCY, ECONOMY AND LONG LIFE FROM THE FIREBOX PARTS.**

### Gas Supply

Where a gas burner is supplied it **MUST** be installed by a competent person in accordance with the current issue of the Gas Safety (Installation and Use) Regulations.

Draw attention, if applicable, to the current issue of Gas Safety (Installation and Use) Regulations, Section 35, which imposes a duty of care on all persons who let out any property containing a gas appliance.

# A. OPERATING INSTRUCTIONS - SOLID MINERAL FUELS

## HOW TO ACHIEVE THE BEST PERFORMANCE WITH HIGH EFFICIENCY, ECONOMY AND LONG LIFE FROM THE FIREBOX PARTS.

### A1 FUELS

This roomheater has obtained approval from HETAS Ltd., for burning smokeless fuels, listed below. The HETAS Ltd., appliance approval only covers the use of smokeless fuels in this roomheater. It does not cover the use of other fuels either alone or mixed with smokeless fuels, nor does it cover instructions for the use of other fuels.

The approved fuels for your Parkray roomheater are:

Coalite Nuts, Blazebrite, Phumacite, Phumacite Plus, Sunbrite Doubles, Centurion, Extracite, Pureheat, Maxibrite, Anthracite Large Nuts, Anthracite Small Nuts as detailed in the HETAS Ltd., List, and Welsh Dry Steam Coal, large and small nuts.

Some fuels may cause staining of the glass panels.

**WARNING:** Petroleum based coke can be dangerous. It can cause fumes, flue gas explosions and structural damage.

Petroleum based coke in its pure form or as part of a blended fuel, must not be used on this appliance.

### SOLID MINERAL FUELS.

Order from an Approved Coal Merchant.

Make sure that your solid fuel merchant supplies you with the correct type and size of fuel. If you are in doubt about the suitability of a particular fuel, please contact your Approved Coal Merchant for advice, or Complete Heat Service, Tel: 0602 272180.

**STORAGE:** Solid Mineral Fuel should be stored in a ventilated but weatherproof bunker or similar store, the base of which should provide drainage. The use of wet fuel or materials on the fire will cause corrosion of internal parts.

### A2 FIRELIGHTING

**111 MODEL ONLY:** If you have been burning wood the throat plate will have been removed.

If you have been burning bituminous coal then a double throat plate will have been fitted.

To burn solid mineral fuel the **SINGLE** throat plate must be refitted.

This change must be made **BEFORE** lighting the fire.

Store the double throat plate in a safe place, ready for use if you go back to burning bituminous coal.

4868

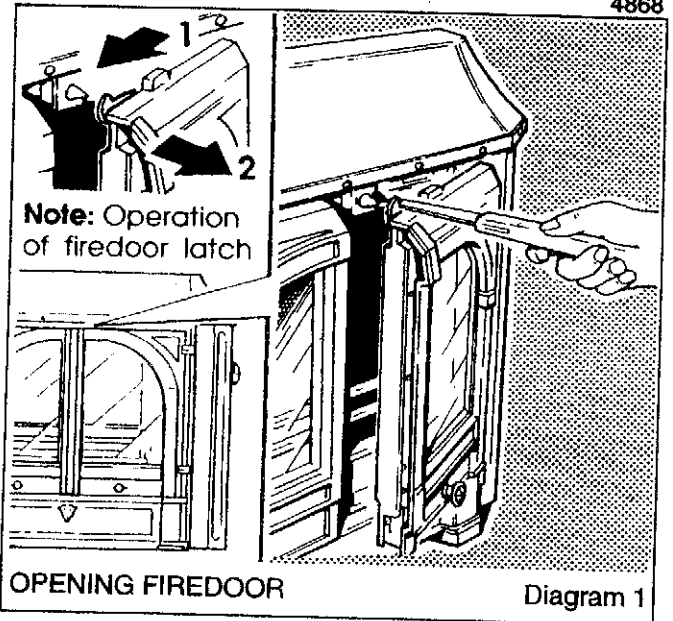

4869

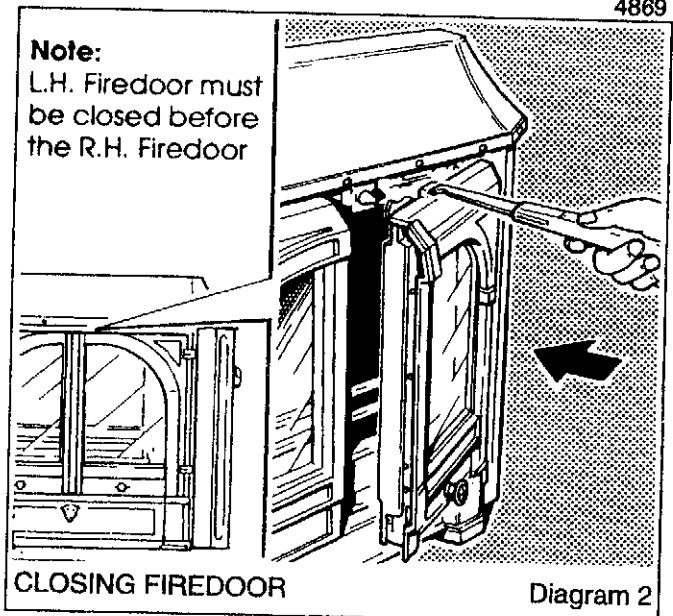

4870

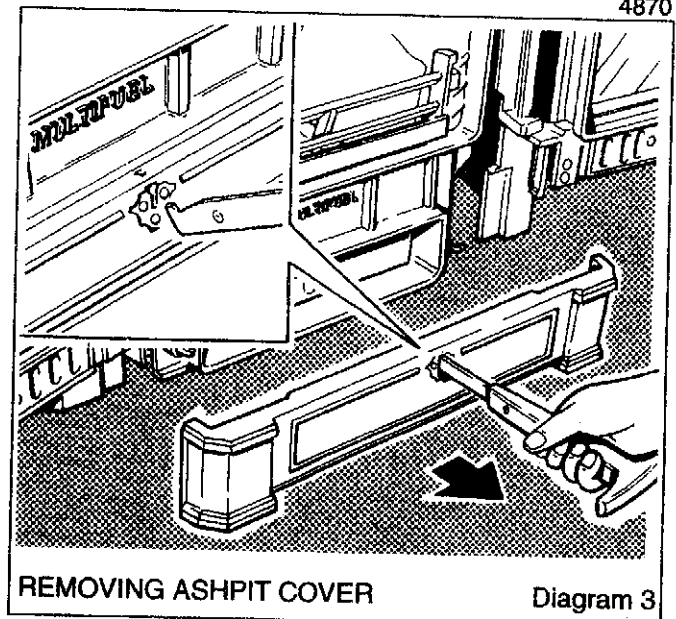

**ALL MODELS:** Ensure that the throat plate is correctly fitted and that the secondary air vents are fully closed (both slid inward toward the centre). Set the control knob to its fully open position No.10.

Open firedoors, see diagram 1. Cover the bottomgrate with rolled up newspaper and add a layer of kindling wood. (Short thin pieces of hardwood are best). Add a 3inch layer of fuel on top of the kindling and light. Close the firedoors, see diagram 2. Ensure that the ashpit cover is in position and fully closed.

When the fire is well established add more fuel to the level of the top of the front firebars, sloped upward toward the back of the firebox. Close the door and set the control knob to give the comfort conditions required.

Experience will show the best setting for your needs. If preferred solid type firelighters may be substituted for the paper and sticks.

**NOTE:** When burning solid mineral fuels this room heater **SHOULD NOT** under any circumstances be run for any period of time with the firedoors open.

If using a Parkray gas burner fill the firebox with fuel to the height of the front firebars close firedoors remove ashpit cover and ashpan diagram 3 and 5. The ashpit cover will stand upright on the hearth, diagram 4. Light the gas burner and with the handle on the Right Hand side place it on the hooks either side of the ashpit opening, see diagram 6.

**WARNING.** During lighting if the gas burner is found to have gone out **TURN THE GAS OFF.** **DO NOT** attempt to relight for at least 15 minutes.

When the fuel is well alight turn off the gas and remove the Parkray burner. Replace the ashpan and the ashpit cover. Add more fuel until level with the top of the front firebars, sloping it upward toward the back of the firebox. Finally, set the control knob according to the comfort conditions required, see diagram 7.

**\*IMPORTANT.** Do not overheat your Parkray roomheater by leaving the gas alight for too long when using the Parkray gas burner.

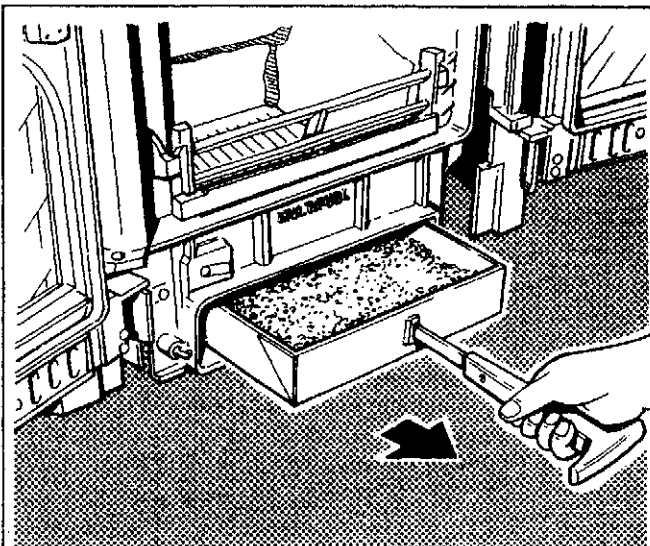

REMOVING THE ASHPAN

Diagram 5

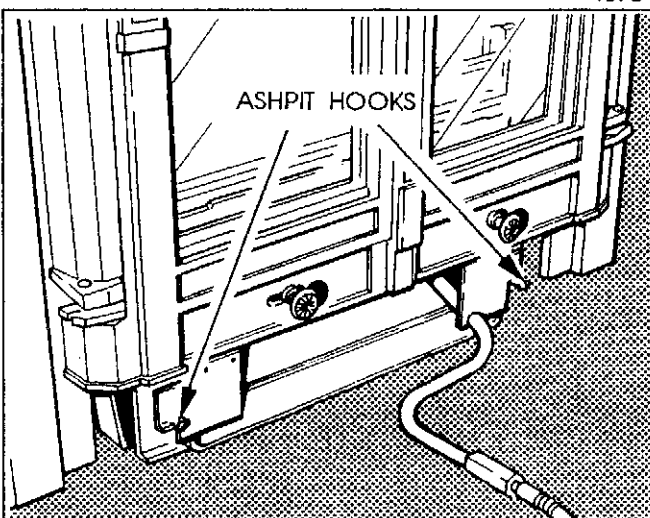

LIGHT BURNER BEFORE PLACING ON ASHPIT HOOKS

Diagram 6

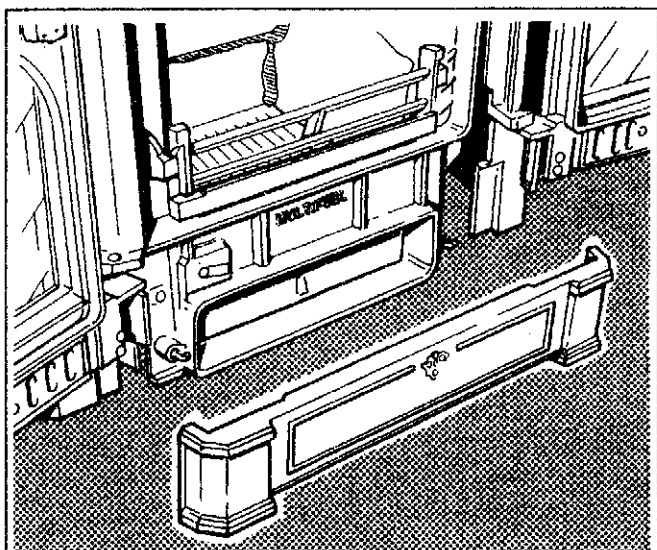

ASHPIT COVER STANDING ON HEARTH Diagram 4

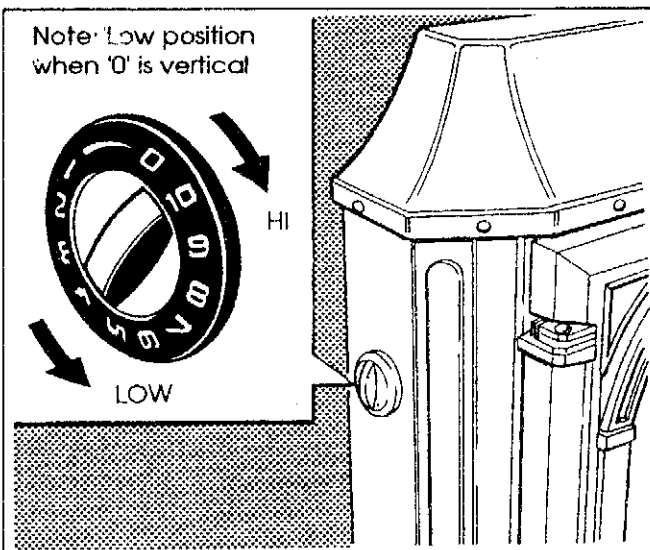

CONTROL KNOB

Diagram 7

### A3 CONTROLS

The heat output of your Parkray roomheater is controlled by the air control plate. Experience will dictate the appropriate control setting for the desired comfort conditions, fuel and heat requirements.

Fuels respond differently to changes in the control (draught) settings, so when changes in heat output are needed, make only small adjustments in the control setting and wait for the temperature to stabilise.

The secondary air vents should be fully closed sliding them inward toward the centre line of the doors, see diagram 8.

36 MODEL. This has a manual control, turning of the control knob, see diagram 7, directly operates the position of the air control plate experience will soon show the setting most suitable for your heating needs. Set the control knob to a high number to increase the output and a low number to reduce it.

99 and 111 MODEL. These models are fitted with a thermostatic control which responds to the water temperature within the boiler. Setting the control knob, see diagram 7, to a high number will give a higher water temperature and setting to a lower number a lower water temperature.

66 MODEL. The thermostatic control responds to the firebox temperature. The number, when positioned at the top of the control knob shows the control settings, that is, a high number for high output and a low number for a low output.

### A4 STOKING

Your roomheater will operate most efficiently and economically if the firebox is kept reasonably full at all times. The large volume of fuel will result in more contact between burning fuel and the appliance surfaces, thereby achieving greater heat transfer into the room or boiler. The fuel should be sloped upward from the top of the front firebars toward the back of the firebox, but do not allow fuel to exceed the height of the throat plate at the rear.

NB. Do not allow fuel to project forward of the firebars or become trapped between the front firebars and the inside of the glass door.

### A5 DE-ASHING

Your Parkray roomheater will work at its most efficient level if you keep the fire free from ash, stone and clinker.

Before shaking the grate you should turn the control knob to "0". Keep the fire doors closed. Engage the operating tool into the slot in the de-ashing knob, diagram 9, on the right hand side of the appliance and move it up and down vigorously. Always de-ash immediately prior to refuelling and thereafter when necessary.

NB. The use of a poker will be beneficial with ashy fuel. In particular, make sure that the entry to the boiler flueway at the back of the firebox of the 99 model is kept clear.

4875

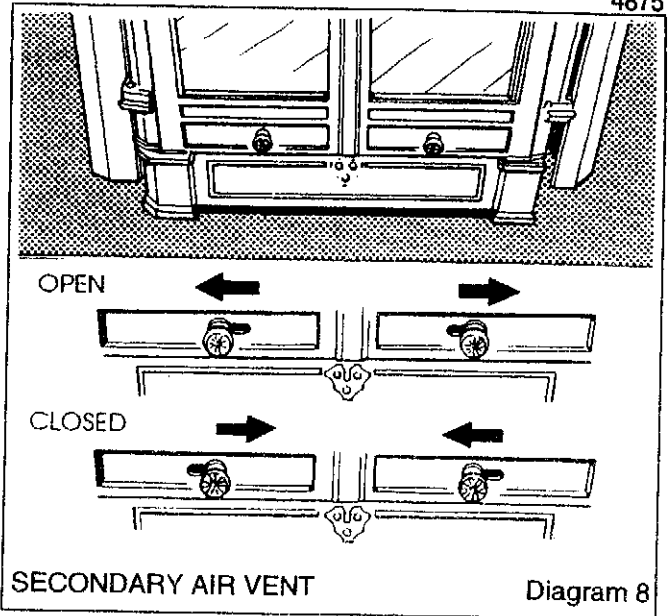

4876

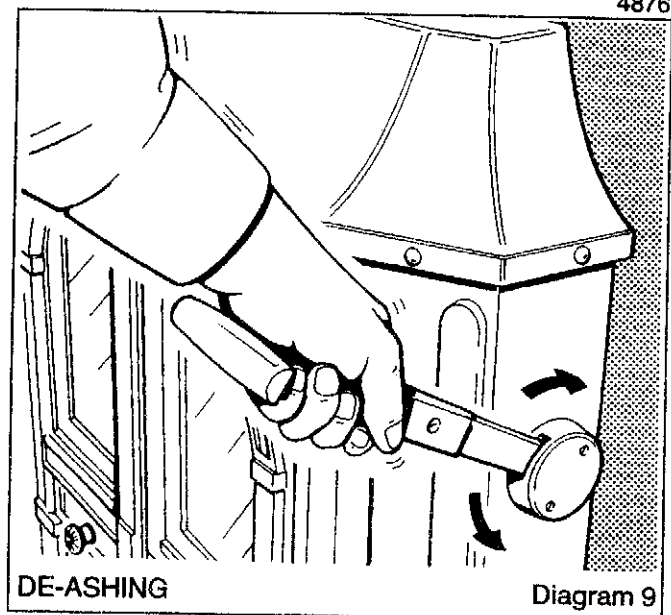

4877

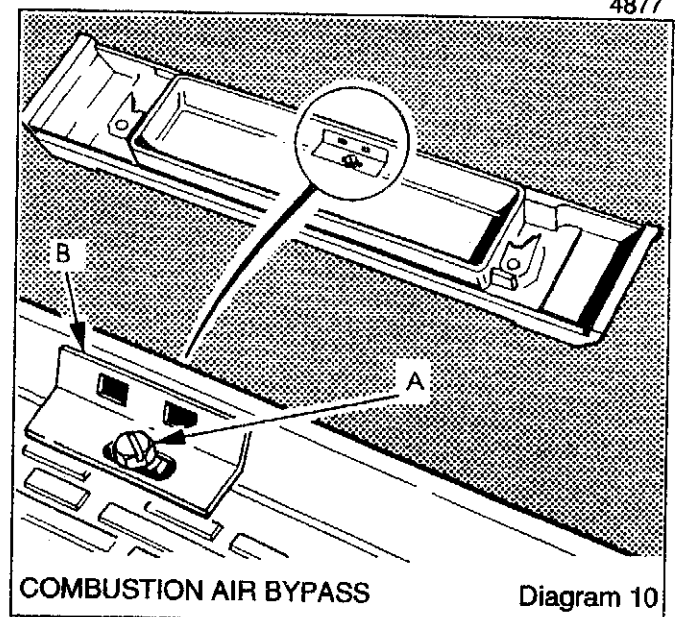



## A6 ASH CLEARANCE

Always empty the ashpan before it is over full, at least once a day. In cold weather or when the fuel is ashy it may be necessary to empty more frequently. While the ashpan is removed ensure that the ashpit and air inlet are free from unburnt fuel and ash which could prevent closure of the air control plate and location of the ashpan. Ashes should never be allowed to accumulate in the ashpit so that they hinder in anyway the flow of combustion air to the fire. Excess ash accumulation may cause the fire to go out and can also cause severe damage to the firebox.

To empty the ashpan remove the ashpit cover with operating tool, see diagram 3. Engage the tool into the slot in the ashpan and withdraw carefully from the appliance, see diagram 5. Temporarily replace the ashpit cover whilst emptying the ashpan. Make sure that the ash is cool before emptying into plastic bins or liners.

Replace ashpan after emptying, then replace ashpit cover. Check that it is correctly located and firmly closed.

## A7 OVERNIGHT BURNING

Use smaller fuel for the best results. Bank on a low bright firebed, about 2 inches deep. First clear the fire of ash and rake level. Empty ashpan. Turn the thermostat control knob to the maximum setting for a few minutes to brighten the fire. Fill the firebox with fuel to the top of the front firebars, sloping it upward toward the back of the firebox. Close the firedoors and reset the control knob to a lower number. Experience will dictate the correct setting for the type of fuel used and the draught available.

## ANTHRACITE BURNING

After overnight burning, when refuelling on a low bed, operate the roomheater with the secondary air vents open, until flames break through the fuel bed.

Return the secondary air vents to their normal operating positions.

## COMBUSTION AIR BYPASS

The combustion air bypass is located on the inner side of the ashpit cover and is set closed at the factory. If the fire dies when shut down, see Section A9, the air bypass should be opened. You should open the firedoor and remove the ashpit cover. Laying the ashpit cover face downward, when it has cooled, loosen screw "A" located in the centre of the cover. Having loosened the screw, move the perforated metal slide "B" in the direction indicated so as to partially uncover the three square holes underneath, see diagram 10. At first try it with the holes a quarter open. If the problem persists increase the opening gradually until resolved.

# A. OPERATING SECURITY

## A8 FIRE BLAZING OUT OF CONTROL

Make sure that:

- (1) The ashpit cover is properly fitted and closed.
- (2) The firedoors are fully closed and the latch is engaged.
- (3) The control knob is turned down to minimum.
- (4) The secondary air vents are in the correct position.
- (5) A recommended fuel is being used.

## A9 SMELL OF FUMES OR FUEL WILL NOT BURN.

**WARNING NOTE.** Properly installed and operated in accordance with these instructions the roomheater will not give off fumes under normal use. Occasional fumes from de-ashing and refuelling may occur. Persistent fume emission must not be tolerated.

However, if fumes are given off:

- (1) Ensure that an extractor fan is not fitted in the same room as the roomheater, as this may result in flue pull reversal.
- (2) Check that there are no deposits of soot built up on the throat plate.
- (3) Check that the chimney is free of any obstruction or blockage, clear if necessary.

**IMPORTANT.** If fume emission persists IMMEDIATE action must be taken.

- (1) Open house doors and windows to ventilate the room.
- (2) Let the fire out or eject and safely dispose of fuel from the roomheater.
- (3) Check that the chimney has been swept clean immediately before installation and periodically since.
- (4) Check that the chimney is sound and has no cracks or other faults which might allow fumes into the house. Older properties especially may have chimney faults.

Do not attempt to relight the fire until the cause of the fumes has been identified and corrected.

If necessary, seek professional advice.

**A10 BOTTOMGRATE BARS DISTORTING OR FAILING PREMATURELY. DIAGRAMS 11 AND 12**

Distortion of the bottomgrate bars will occur if any of the following circumstances is allowed to persist:

- (1) Leaving the gas alight for too long when using the gas burner.
- (2) Leaving the ashpit cover off for prolonged periods whilst firedoor is closed.
- (3) The use on non-recommended fuels.
- (4) Allowing ash to accumulate until it touches the underside of the bottomgrate, or ash and clinker to remain in the firebed.
- (5) Incorrect positioning of the cast-iron and chrome-iron bottomgrate bars in the firebed.
- (6) On the 99 and 111 the heat requirements are too much for the roomheater and/or the system is not properly balanced to operate efficiently with the correct water circulation rate. Ask your installer to check if this is the case.

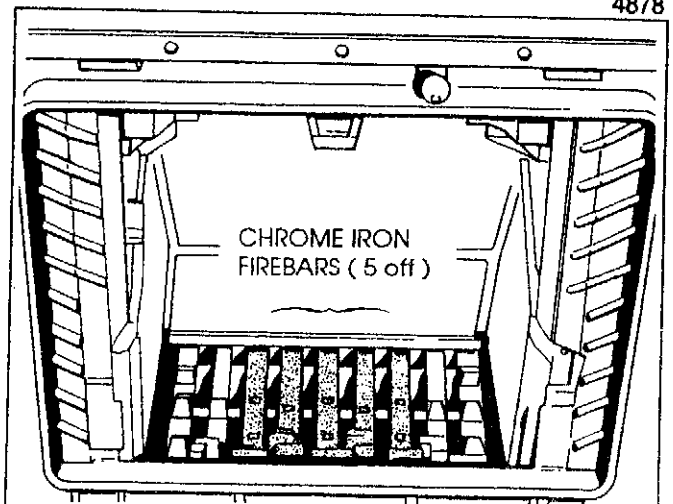

**BOTTOMGRATE SHOWING THE CHROME IRON FIREBARS IN THE CENTRE (36 ILLUSTRATED ABOVE) Diagram 11**

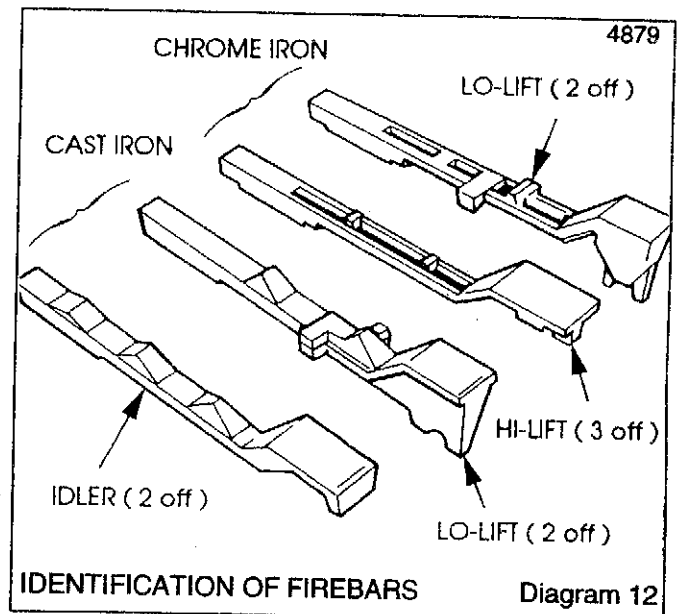

**IDENTIFICATION OF FIREBARS Diagram 12**

## A. ROUTINE BUT ESSENTIAL SAFETY PROCEDURE

### A11 FLUE CLEANING

It should be emphasised that where the chimney is believed to have served an open fire installation it is possible that the higher flue gas temperature from a closed roomheater may loosen deposits that were previously firmly adhered, with the consequence risk of flue blockage. It is therefore recommended that the chimney be swept a second time after one month of regular use.

It is essential that the chimney and entry to it be kept clear. The roomheater throat plate must be cleaned at least monthly. This is a convenient and straight forward operation.

Engage the operating tool into the slot at the front of the throat plate. Draw the throat plate forward to its stop and lower towards the firebed, see diagram 13 for 36/66 Model and diagram 14 for 111 Model. Brush the underside of the top casting and top of the throat plate. Any soot or fly ash will pass into the firebox. After cleaning lift the throat plate with the operating tool and push back into its operational position.

On the 111 Model make sure that the pin on the throat plate engages into the hole in the inner front casting.

On the 99 model engage the operating tool into the slot at the front of the throat plate, draw the throat plate fully forward to its stop. This will automatically scrape any deposit from the top of the throat plate into the firebox see diagram 15. Brush the underside of the throat plate and top casting.

After fully cleaning push the throat plate back into its original position.

4880

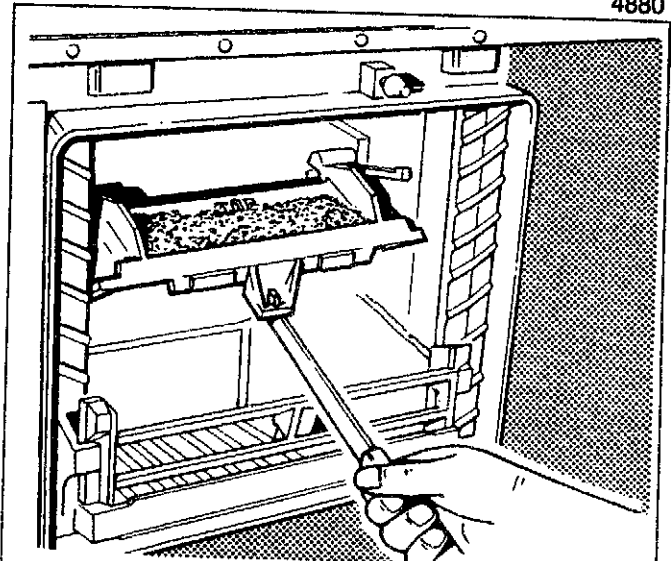

CLEANING THE THROATPLATE 36 & 66 Diagram 13

4881

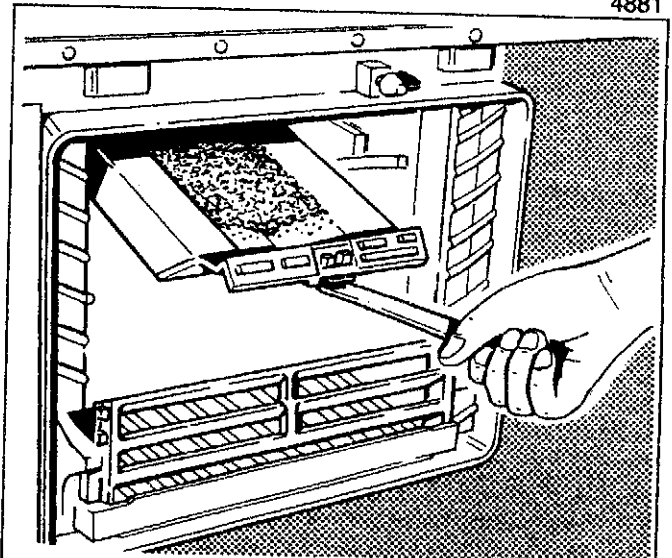

CLEANING THE THROATPLATE 111 Diagram 14

4882

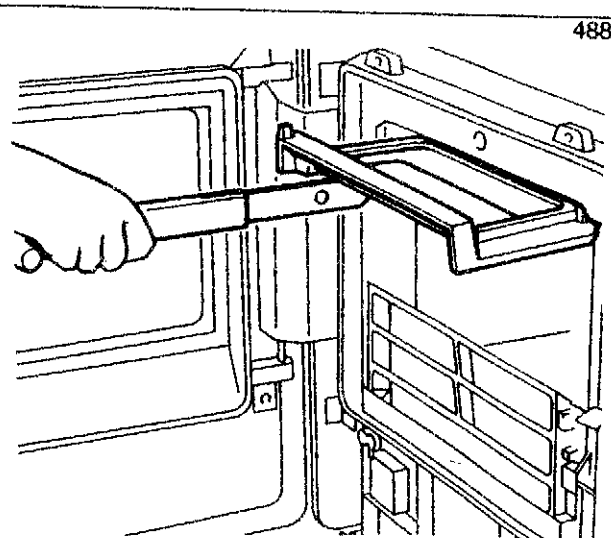

CLEANING THE THROATPLATE 99 Diagram 15

## A12 CHIMNEY SWEEPING

### IMPORTANT.

It is recommended that the chimney is swept at least twice a year to enable the products of combustion to pass freely up the flue.

**36/66 MODEL.** Engage the operating tool into slot at the front of the throat plate. Draw the throat plate forward to its stop. Lift throat plate at rear and withdraw and remove from the appliance, see diagram 16. Remove the front firebars.

**99 MODEL.** Engage the operating tool into the slot at the front of the throat plate. Raise the front edge of the throat plate and draw forward to the stop. Then raise the the stop latch and draw the throat plate forward until clear of the appliance, see diagram 17. Remove the front fire bars.

Using a sweep's wire centred brush with a guide wheel sweep the chimney through the fire opening.

Finally, replace the throat plate by engaging into the ribs on the sides of the boiler.

Raise the stop latch and push the throat plate fully back.

**111 MODEL.** Engage the operating tool into the slot at the front of the throat plate. Draw the throat plate forward to stop. Lift the throat plate at rear withdraw forward and remove it from the appliance, see diagram 18. Remove the front firebars.

**36/66/111 MODELS.** Using a sweep's wire centre brush with guide wheel, sweep the chimney through the fire opening. Replace the throat plate, by engaging lugs into the channels at rear, push towards rear and engage pin (see "Flue Cleaning"). After sweeping remove any material, such as soot or fly ash, which has collected on top of the boiler, before replacing the throat plate.

On the 99 model clean the flueway with a brush.

## A13 PERIODICAL SHUTTING DOWN

When the fire is not in use for period of time clean all internal surfaces thoroughly, including the throat plate and flue outlet. Leave the fire with the control knob at position 10 and the secondary air vents fully open.

Before relighting after a prolonged shut down it is important to clean the room heater flueways, flue pipe and chimney.

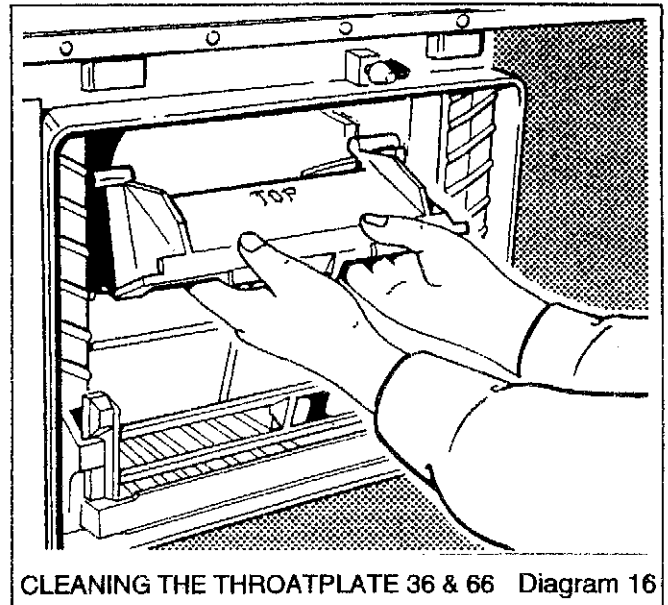

4883

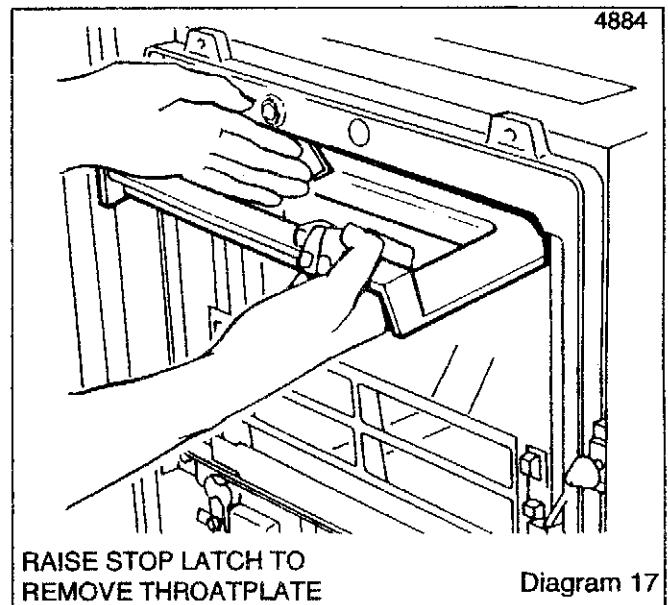

4884

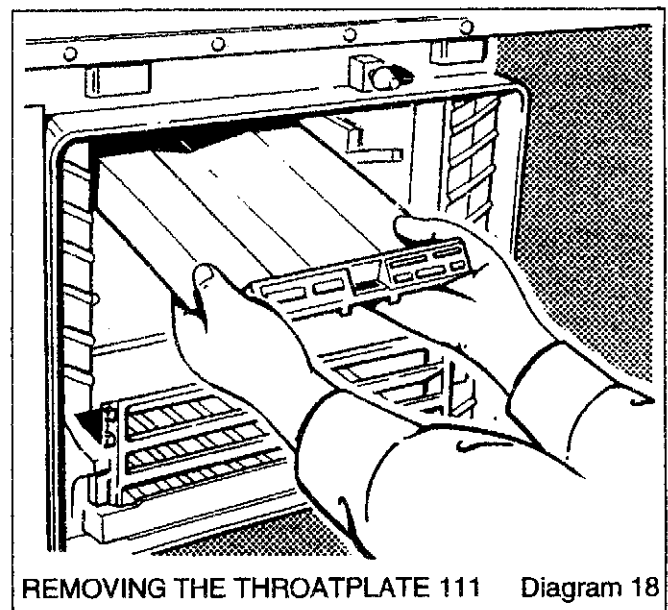

4885

## **B. OPERATING INSTRUCTIONS WOOD AND BITUMINOUS COAL BURNING**

*Wood and Bituminous Coal should NOT be used in a smoke controlled area.*

### **HOW TO ACHIEVE THE BEST PERFORMANCE WITH HIGH EFFICIENCY, ECONOMY AND LONG LIFE FROM THE FIREBOX PARTS.**

111 MODEL ONLY. If this roomheater is to be used with bituminous coal then the bituminous coal burning double throat plate **MUST** be in place.

The appropriate double throat plate can be obtained, free of charge, from Hepworth Heating Ltd., by completing and returning the prepaid form on page 19.

### **ALL MODELS**

This roomheater may be operated using a 150mm (6in) diameter flue system when burning bituminous coal or wood, providing the fire doors remain **CLOSED**.

If the roomheater is to be operated with the doors open (wood burning only) then the flue must have a minimum diameter of 200mm (8in).

This roomheater must not be operated with the fire doors open when burning bituminous coal.

Note: If the roomheater incorporates a 150mm (6in) diameter flue system and bituminous coal or wood are burnt then it may be necessary to sweep the chimney more often.

### **B1 FUELS.**

**WOOD:** Only well seasoned split logs up to a maximum of 9 inches (230mm) on the 36/66 model, 11 inches (280mm) on the 99 model and 14 inches (355mm) on the 111 model long should be used, preferably hardwood. Do not fire the roomheater on wet or unseasoned wood as this will lead to creosote and tar formation in the firebox and flue. The appliance efficiency will be lowered, also tar may ignite and cause a chimney fire. The output of the roomheater will be less when burning wood.

**STORAGE:** Wood should be stored in well ventilated stacks. If outdoors cover the top to protect against rain or snow. Leave the sides open to provide ventilation to the stack. Radial cracks across the ends of a log usually indicate that the log is seasoned enough to burn.

**BITUMINOUS (HOUSE) COAL:** Double and trebles (nuts and large nuts).

**STORAGE:** Coal should be stored in a ventilated but weatherproof bunker or similar store, the base of which should provide drainage. The use of wet fuel or materials on the fire will cause corrosion of internal metal parts.

### **B2 FIRELIGHTING**

111 MODEL ONLY. If you have previously been burning solid mineral fuel the single throat plate will be in place, for bituminous coal burning this single plate **MUST** be replaced with the double throat plate, or if burning wood, removed, see diagram 18.

This change must be made **BEFORE** lighting the fire.

**NOTE:** Store the single throat plate in a safe place ready for use if you go back to burning solid mineral fuel.

**ALL MODELS.** Set control knob, see diagram 7, to position "O". Fully open both secondary air vents - slide outward away from the centre, see diagram 8.

Open fire doors, see diagram 1, cover bottom grate with rolled up newspaper and cover with a layer of kindling wood.

(Short thin pieces of hardwood are best). Light paper and close fire doors, see diagram 2. Check ashpit cover is in position and fully closed. If preferred solid type firelighters may be used instead of paper. When the kindling wood is burning strongly either:

(a) add a layer of larger pieces of wood finally loading the firebox when the fire is fully established or -

(b) add a further layer of bituminous coal finally loading the firebox with bituminous coal when the fire is fully established.

Gradually close down the secondary air vents pushing them equally outward to give the comfort conditions required. Experience will show the best setting for your needs.

If it is found that you cannot get the burning rate with the secondary air vents fully open then set the control knob to 1 or 2.

### **B3 CONTROLS**

The heat output of your Parkray roomheater is controlled by the secondary air vents. Experience will give the appropriate control setting for the desired comfort conditions.

This setting will vary from one household to another due to differences in draught conditions, fuel and heat requirements. Fuels respond differently to changes in the control (draught) settings, so when changes to heat output are needed, make only small adjustments in the control setting and wait for the temperature to stabilise.

Turn the control knob to position "O". Initially open the two secondary air vents fully each pushed away from the doors centre joint line. Close down the vents gradually sliding them toward the centre in equal amounts until the desired burning rate is achieved. If the burning rate is sluggish with the air vents fully open, turn the control knob to position 1 or 2 then control down on the air vents.

### **B4 STOKING**

Your roomheater will operate most efficiently and economically if the firebox is kept reasonably full at all times. The large volume of fuel will result in more contact between burning fuel and the appliance surfaces, thereby achieving greater heat transfer into the room or boiler. The fuel should be sloped upward from the top of the front firebars toward the back of the firebox, but do not allow fuel to exceed the height of the throat plate at the rear.

**WOOD:** Use split logs up to a maximum length of 9 inches (230mm) on the 36/66 Models, 11 inches (280mm) on the 99 model and 14 inches (355mm) on the 111 Model. Load firebox fully but do not allow logs to exceed the height of the throat plate at the rear. If the fire is very low at refuel it is beneficial to add a small amount of fuel first, set the air control knob to a high setting and allow the fire to re-establish before fully loading the stove. The air control knobs should then be reset to give the required comfort level.

**BITUMINOUS COAL:** It is generally best to refuel the fire just before a heating up period when the secondary air vents are open. Always open the fire doors slowly and with caution after refueling. Try and refuel to full charging level in one operation to avoid opening up for a second charge.

**NOTE: BOTH FUELS.** Do not allow fuel to project forward of the front firebars or become trapped between the front firebars and the inside of the glass door.

## B5 DE-ASHING

**WOOD:** Throughout normal operation some ash will fall through the bottomgrate automatically. It is good practice to establish a bed of ash on the bottomgrate as this will retain heat and allow the roomheater to burn for extended periods. If the ash bed becomes excessive de-ash as necessary.

**BITUMINOUS COAL:** Your Parkray roomheater will work at its most efficient level if you keep the fire free from ash, stone and clinker.

Before shaking the grate you should turn the control knob to "0" and close the secondary air vents. Keep the fire door closed. Engage the operating tools into the slot in the de-ashing knob, see diagram 9, on the right hand side of the room heater and move it up and down vigorously. Always de-ash immediately prior to refuelling and thereafter when necessary.

**NB.** The use of a poker will be beneficial with ashy fuels. In particular, ensure that entry to the boiler flueway at the back of the firebox of the 99 model is kept clear.

## B6 ASH CLEARANCE

Always empty the ashpan before it is overfull, at least once a day when burning coal, see "De-ashing" above. While the ashpan is removed ensure that the air inlet is free from unburnt fuel and ash which could prevent closure of the air control plate.

To empty the ashpan remove the ashpit cover with operating tool, see diagram 3. Engage the tool into the slots in the ashpan and withdraw carefully from the room heater, see diagram 5. Temporarily replace the ashpit cover whilst emptying the ashpan. Make sure that the ash is cool before emptying into plastic bins or liners. Ash should not be allowed to build up on the shaker bar support or under the front protection plate as this may impair the operation of the de-ashing mechanism. Replace ashpan after emptying, then replace ashpit cover. Check that it is correctly located and firmly closed.

## B7 OVERNIGHT BURNING

**WOOD:** Long burn times are best achieved by the use of wood of the maximum size which your roomheater will accommodate, hardwoods, for example, elm, oak, will burn for longer periods than softwoods such as, pine.

Refuel the roomheater onto the level, hot bed of ash, about 2inches deep. Set the secondary Long slow fully open for a few minutes until the bottom logs are alight, then slide the vents shut. Experience will determine the best setting to give a long burn, but still consuming a large proportion of the fuel over the burn time. Long slow burns will aggravate the formation of soot, creosote and tars in the firebox and flue.

Always burn at a high rate for a period of about twenty minutes or more after a slow burn to reduce creosote deposits.

If a hot enough temperature is attained during a high burn period this will remove deposits which accumulate on the door glass overnight. If the deposits are more than a light film it is recommended that the glass door is cleaned, with a ceramic hob cleaner, before the fire is recovered.

**BITUMINOUS COAL:** With bituminous coal it is generally best to refuel the roomheater about an hour before retiring while the controls are set higher. This will enable the smoke in the coal to be usefully burnt off and help to alleviate soot and tar problems after the the controls are set down for slow burning. For slow burning set the control knob to "0", reposition the secondary air vents always leaving them slightly open. Experience will determine the correct setting for the draught available.

**NOTE: BOTH FUELS.** If the fire dies out open up the air vents slightly until suitable conditions are obtained.

# B. OPERATING SECURITY

## B8 FIRE BLAZING OUT OF CONTROL

Ensure that:

- (1) The ashpit cover is properly fitted and closed.
- (2) The fire doors are fully closed and the latch is engaged.
- (3) The thermostat control is turned down to minimum.
- (4) The secondary air vents are in the correct position.

## B9 SMELL OF FUMES OR FUEL WILL NOT BURN.

**WARNING NOTE.**

Properly installed and operated in accordance with these instructions the roomheater will not give off fumes under normal use. Occasional fumes from de-ashing and refueling may occur. Persistent fume emission must not be tolerated.

However, if fumes are given off:

- (1) Ensure that an extractor fan is not fitted in the same room as the roomheater, as this may result in flue pull reversal.
- (2) Check that there are no deposits of soot, tar or creosote built up on the throat plate, if fitted.
- (3) Check that the chimney is free of any obstruction or blockage and clear if necessary.

**WARNING - IMPORTANT**

If fume emission persists IMMEDIATE action must be taken.

- (1) Open house doors and windows to ventilate the room.
- (2) Let the fire out or eject and safely dispose of fuel from the roomheater.
- (3) Check that the chimney has been swept clean immediately before installation and periodically since.
- (4) Check that the chimney is sound and has no cracks or other faults which might allow fumes into the house. Older properties especially may have chimney faults.

Do not attempt to relight the fire until the cause of the fumes has been identified and corrected.

If necessary, seek professional advice.

## B. ROUTINE BUT ESSENTIAL SAFETY PROCEDURE

### B10 FLUE CLEANING

It should be emphasised that where the chimney is believed to have served an open fire installation it is possible that the higher flue gas temperature from a closed roomheater may loosen deposits that were previously firmly adhered, with the consequent risk of flue blockage. It is, therefore, recommended that the chimney be swept a second time after one month of regular use. It is essential that the chimney and entry to it be kept clear. The throat plate, if fitted, must be cleaned at least monthly.

If burning bituminous coal, Model 111 only, refer also to further instructions below.

(On Model 111, burning wood, the throat plate will have been removed).

#### MODEL 36/66

Engage the operating tool into the slot at the front of the throat plate. Draw the throat plate forward to its stop and lower toward the firebed, see diagram 13. Brush the underside of the top casting and top of throat plate. Any soot or fly ash will pass into the firebox. After cleaning lift the throat plate with the operating tool and push back into its operational position.

On the 99 model engage the operating tool into the slot at the front of the throat plate, draw the throat plate fully forward to its stop. This will automatically scrape any deposit from the top of the throat plate into the firebox see diagram 15. Brush the underside of the throat plate and top casting.

After fully cleaning push the throat plate back into its original position.

#### MODEL 111 ONLY

Bituminous Coal burning.

It is **IMPORTANT** that the throat plate is cleaned at least once a month, but preferably, it should be done **ONCE A WEEK**.

Warning. Before cleaning the throat plate make sure that there is no more than a low fire.

Use the tool to remove the front firebars.

Engage the tool into the slot at the front of the throat plate, lift slightly, draw forward and lower, see diagram 19, clean the top of the throat plate and underside of top casting, allow the dust to fall into the lower compartment.

Engage the tool again as shown in diagram 20, lift slightly to allow the lower part of the throat plate to disengage, clean out.

Replace in the reverse order to removal.

To remove the throat plate completely, **MAKE SURE THAT THE ROOM HEATER IS COLD**, grip the throat plate at the front as shown in diagram 21, lift slightly and allow the bottom half of the throat plate to slide forward and remove. Repeat this operation to remove the top half, see diagram 22.

Replace in the reverse order to removal.

Ensure the pin on the throat plate engages into the hole in the inner front casting.

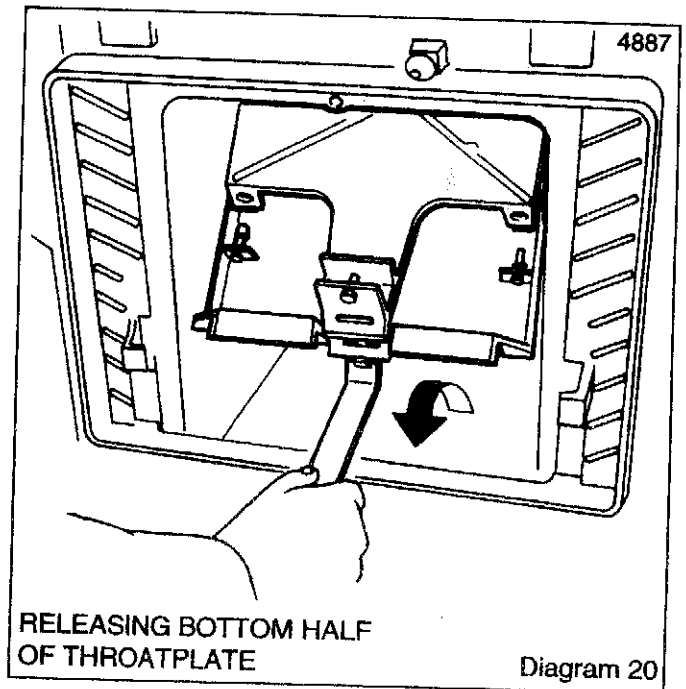
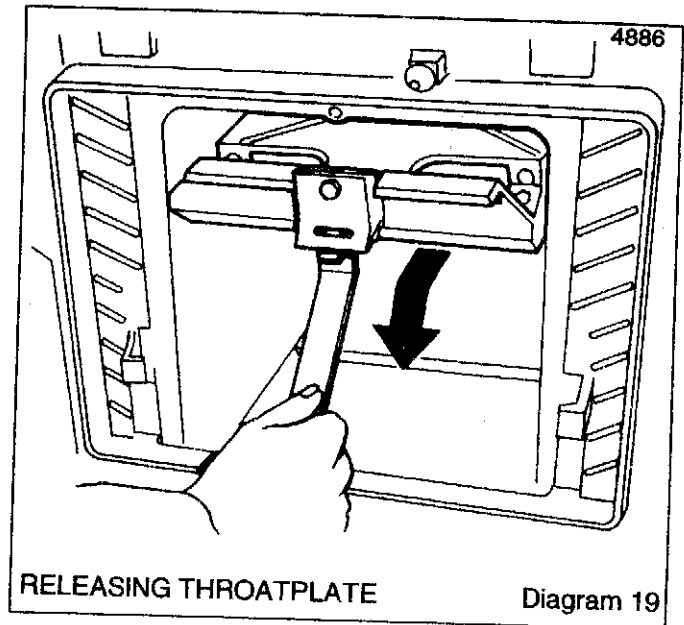

## B11 CHIMNEY SWEEPING

### IMPORTANT

It is recommended that the chimney is swept at least twice a year to enable the products of combustion to pass freely up the flue. More frequent chimney sweeping may be required if tar and creosote form on a regular basis.

This roomheater may be operated using a 150mm (6in) diameter flue system when burning bituminous coal or wood, providing the firedoors remain CLOSED.

If the roomheater is to be operated with the doors open, wood burning only, then the flue system must have a minimum diameter of 200mm (8in).

Note: If the roomheater incorporates a 150mm (6in) diameter flue system and bituminous coal or wood are burnt then it may be necessary to sweep the chimney more often.  
36/66 MODEL. Engage the operating tool into slot at the front of the throat plate.

Draw the throat plate forward to its stop. Lift throat plate at rear and withdraw and remove from the roomheater, see diagram 15. Then remove the front firebars.

99 MODEL. Engage the operating tool into the slot at the front of the throat plate, see diagram 15. Raise the front edge of the throat plate and draw forward to the stop. Then raise the the stop latch and draw the throat plate forward until clear of the appliance. see diagram 17. Remove the front fire bars.

Using a sweep's wire centred brush with a guide wheel sweep the chimney through the fire opening.

Finally, replace the throat plate by engaging into the ribs on the sides of the boiler.

Raise the stop latch and push the throat plate fully back.

ALL MODELS. Using a sweep's wire centred brush with guide wheel, sweep the chimney through the fire opening. Replace the throat plate, by engaging lugs into the channels at rear, push toward the rear and engage pin, see "Flue Cleaning".

After sweeping remove any material, such as soot or fly ash, which has collected on top of the boiler, before replacing the throat plate.

On the 99 model clean the flueway with a brush.

## B12 PERIODICAL SHUTTING DOWN

When the fire is not in use for a period of time clean all internal surfaces thoroughly, including the throat plate and flue outlet. Leave the fire with the control knob at position 10 and the secondary air vent fully open.

Before re-lighting after a prolonged shut down it is important to clean the roomheater, flueways, fluepipe and chimney.

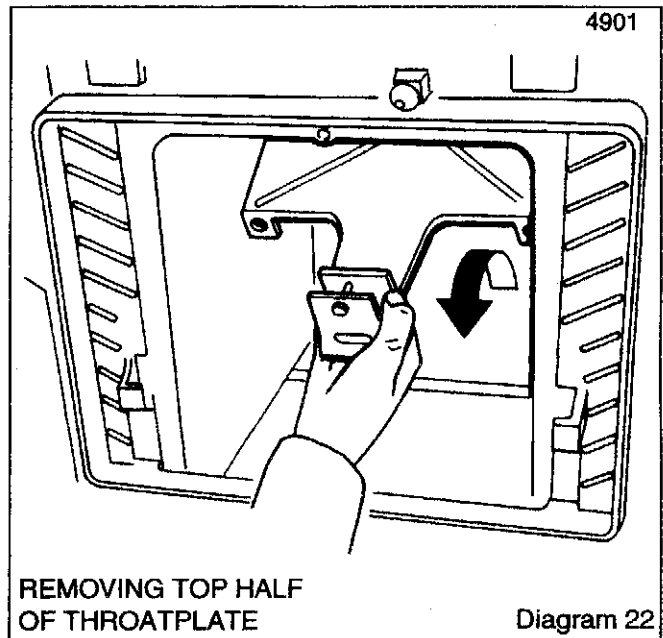
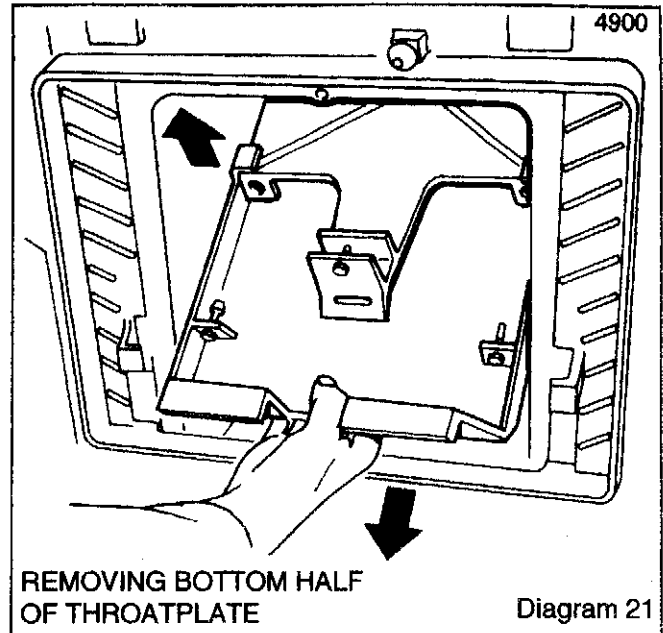



## C. CARE AND CLEANING

### C1 GLASS DOOR

The special ceramic glass withstands temperatures up to the full rating of your Parkray roomheater but may be damaged if allowed to overheat, for example, by removing the ashpit cover.

Remember the glass is fragile and care should be taken not to allow the surface to suffer hard knocks or scratches.

The glass should be cleaned regularly, removing any loose dust from the surface with a soft brush. Then clean with a ceramic hob cleaner, do not use abrasive materials.

Try to avoid burning the fire so slowly that condensation occurs in the firebox and on the inside of the glass.

If condensation occurs regularly, set the control knob to a slightly higher number. Permanent marking of the glass can take place if firebox condensation is allowed to occur on a regular basis.

With "Solid Mineral Fuels" also see Section A7.

Never clean the glass when it is hot or subject to rapid changes in temperature. When necessary scrape away any deposits from the firedoor sealing surfaces.

### C2 ENAMEL AND PAINT FINISH

Wipe the enamelled surface when cool with a damp cloth and finish with a soft dry duster.

Do not use acidic or abrasive cleaners. Be careful that no liquids or materials touch the enamel surface when it is hot.

### C3 INTERNAL METAL PARTS

When your Parkray is not in use (for example, during the summer months) set the control to number 10 to reduce condensation and minimise metal corrosion.

### C4 BRASS DECORATION

On brasses a proprietary brass cleaner may be used then polishing with a dry duster.

### C5 BOTTOMGRATE BARS

When replacing the bottomgrate bars the five "Y" sectioned chrome iron bottomgrate bars should always be placed centrally in the bottomgrate, with the square sectioned cast iron bottomgrate bars to the outsides, see diagram 11 and 12. NB. Movement of the outer bottomgrate bars at each side is restricted. The chrome iron bottomgrate bars are specially designed to withstand the high temperatures present in the centre of the firebed. Incorrect positioning of the cast iron bottomgrate bars in the centre may result in their distortion or premature failure.

## D. WATER SYSTEMS (Not applicable to Model 36) ALL FUELS

### D1 BALANCING THE SYSTEM

For your central heating system to operate at its optimum efficiency, the system must be properly "balanced". This balancing should be undertaken by the installer at the time of installation although it can be done at any time by a competent person.

An unbalanced central heating system will have the following symptoms:

- (1) The radiators will not heat up satisfactorily.
- (2) The domestic hot water cylinder will not re-heat and goes cold when the radiators are on.
- (3) A higher than normal fuel consumption.

### D2 POOR HOT WATER SUPPLY WHEN RADIATORS ARE ON

Ask your installer to check that the system is properly balanced to ensure that the action of the pump is not retarding the circulation to the hot water cylinder.

### D3 WATER HEATING SYSTEM FROZEN

The appliance must not be lit if there is any possibility that parts of the water system may be frozen.

## E. SHORT LIST OF SPARE PARTS

DESCRIPTION	Part No.
Bottomgrate Bars 36/66 Hi-lift cast iron	130086
Bottomgrate Bars 36/66 Hi-lift chrome cast	130356
Bottomgrate Bars 36/66 Lo-lift cast iron	130087
Bottomgrate Bars 36/66 Lo-lift chrome iron	130357
Bottomgrate Bars 111 Idler	130152
Bottomgrate Bars 99 Idler	130082
Bottomgrate Bars 111 Hi-lift chrome	112364
Bottomgrate Bars 99 Hi-lift chrome	130355
Bottomgrate Bars 111 Lo-lift cast iron	112033
Bottomgrate Bars 99 Lo-lift cast iron	130081
Bottomgrate Bars 111 Lo-lift chrome	112365
Bottomgrate Bars 99 Lo-lift chrome	130354
Front Firebars 36/66	130065
Front Firebars 99/111	112039
Glass Panel Pack	150066
Thermostat 66	130371
Thermostat 99/111	115074
Manual Control Knob 36	130436
Control Knob	130093
De-ashing Knob	130091
Ashpan 33/66	130191
Ashpan 111	130195
Ashpan 99	130193
Side Brick LH 36/66	130117
Side Brick RH 36/66	130118
Lower Back Brick 36/66	130119
Upper Back Brick 36	080064

**Always ensure genuine Parkray spare parts are fitted**

Please forward my free Double Throat Plate for the Parkray Chiltern/Cumbria 111  
(Bituminous coal should not be used in a Smoke Controlled area)

I confirm (1) The Chiltern/Cumbria 111 is installed ... ..  Tick  
(2) Bituminous coal will be used ... ..  Tick

Name .....

Address .....

Town .....

County ..... Postcode .....

Signature ..... Date .....

**Send the above to:-**

**PARKRAY LTD** The Britannia Suite, St. James Buildings, 79 Oxford St., Manchester M1 6FR  
Telephone: 0870 240 7376 Fax: 0870 240 7310





The name "Parkray" is a Registered Trade Mark

Strict accuracy of illustrations or printed matter is not guaranteed. Modifications of design and materials may be necessary subsequent to publication

---