

---

# Diva

---

Central heating cooker «La Premiere»

**Ref. 82 914 - 22 kW**

**Ref. 82 916 - 29 kW**



**Description of the appliance**

**Installation instructions**

**Operating instructions**

**Spare parts**

**Warranty certificate**

## Technical manual

to be saved

by the user

for future reference

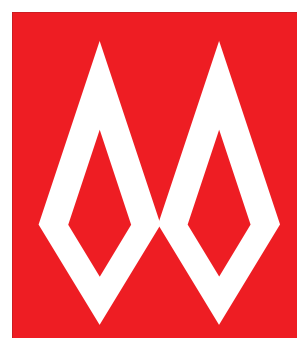

**FRANCO BELGE**

Harworth Heating Ltd

Blythe Road

Harworth

Doncaster

DN11 8NE

Tel: 01302 742520 Fax: 01302 750573

Email: [sales@oilstoves.co.uk](mailto:sales@oilstoves.co.uk)

---

<b>Contents</b>	Page
<b>Description . . . . .</b>	<b>39</b>
Package . . . . .	39
Optional equipment . . . . .	39
Technical details . . . . .	39
<b>Assembly and installation . . . . .</b>	<b>41</b>
Positioning the cooker . . . . .	41
Mounting . . . . .	41
The chimney . . . . .	42
Connection to chimney. . . . .	42
Connecting the central heating circuit. . . . .	42
Adjustments . . . . .	43
<b>Operating instructions . . . . .</b>	<b>45</b>
Checks prior to lighting . . . . .	45
Fuel . . . . .	45
Lighting . . . . .	45
Operation . . . . .	46
Flue draught control box . . . . .	47
Maintenance . . . . .	48
Fault diagnosis. . . . .	49
<b>Spare parts . . . . .</b>	<b>51</b>

# 1. Description

## 1.2. Optional equipment

### 1.1. Package

- Cover in 2 parts in case of a rear flue outlet
- Cover in 3 parts in case of a top flue outlet

1 package

### 1.3. Technical details

		82.914		82.916	
		Total heat output (Btu/hr)	Maximum water heating output** (Btu/hr)	Total heat output (Btu/hr)	Maximum water heating output** (Btu/hr)
Grates in top position	Wood*	44.000	32.000	59.000	47.500
	Solid fuel	55.500	42.000	75.000	63.000
Grates in lowest position	Wood*	67.000	53.000	87.000	73.000
	Solid fuel	71.000	57.000	91.000	77.000

\*When burning dry seasoned wood.

\*\*Water output is measured at a flue draught of 0,006" water gauge and on a loading cycle of 31/2 hours for solid fuel.

Model		<b>82.914</b>	<b>82.916</b>
Capacity of water jacket	litres	22	25
Weight	kg	330	335
Firebox			
Width	mm	300	300
Depth	mm	447	447
Height (maximum)	mm	440	440
Oven			
Width	mm	410	410
Depth	mm	400	400
Height	mm	320	
320 Flue outlet O/D (2)	mm	153	

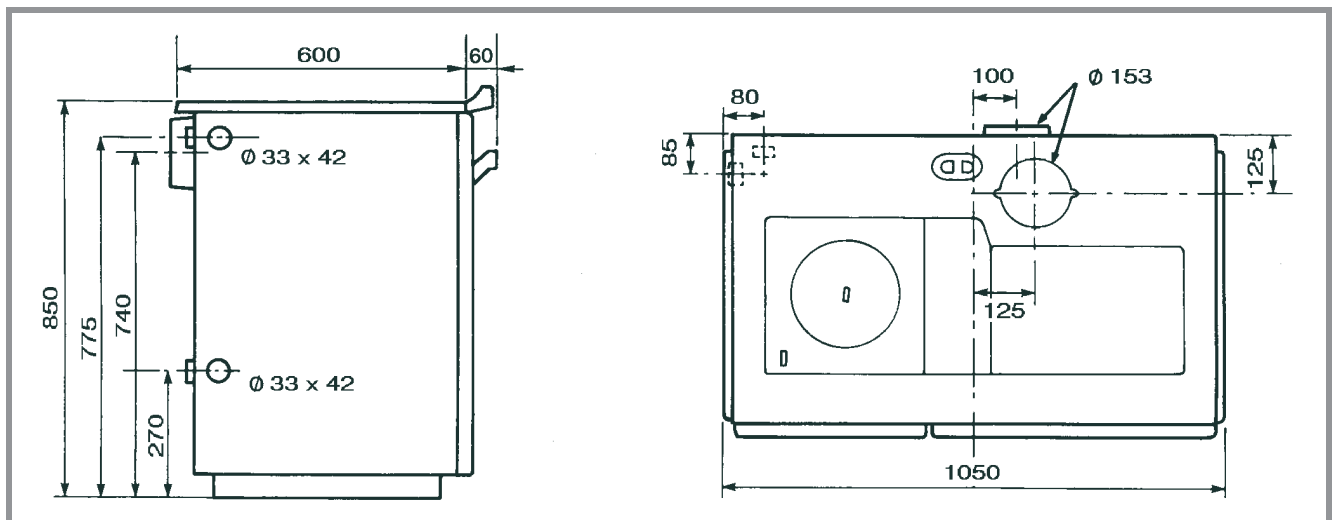

Fig. 1

Fig. 1 - Dimensions in mm

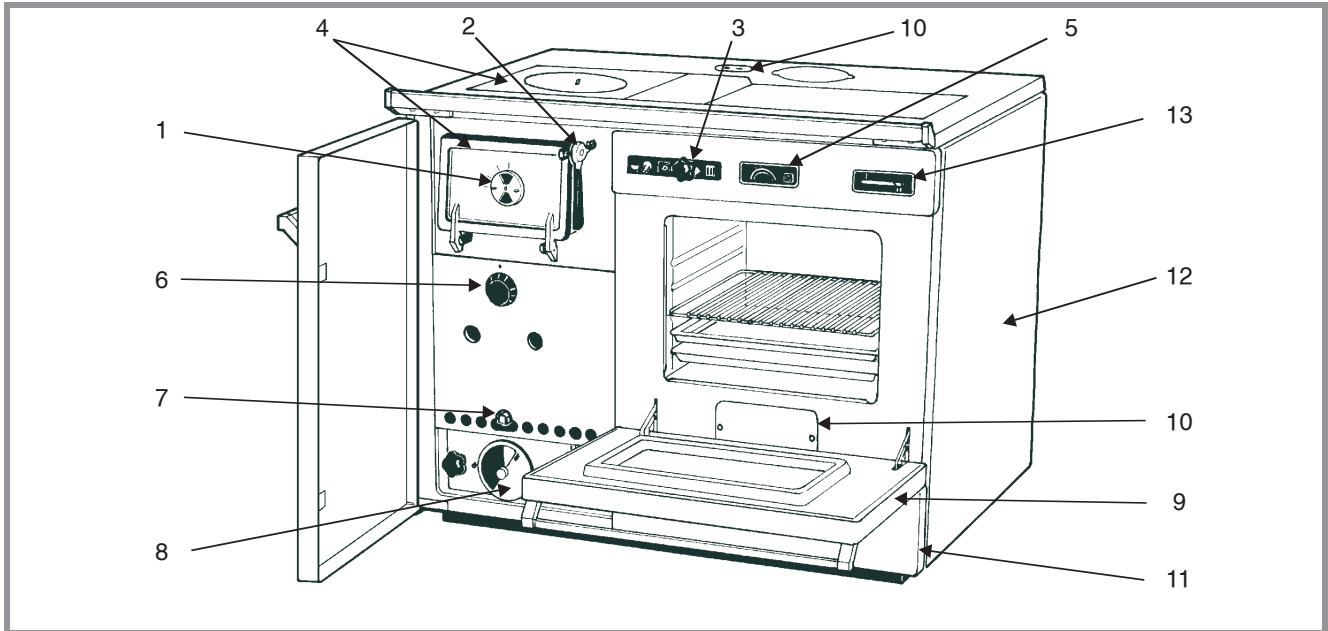

Fig. 2

**Fig. 2 - Operating description of the appliance**

- 1 Secondary air control
- 2 Handle and lock
- 3 The two position heating/cooking control knob.
- 4 Top or front loading. The firebox design allows solid fuel, wood or peat to be burned with equal efficiency and economy.
- 5 Thermometer
- 6 The thermostat automatically regulates the burning rate and helps to maintain a constant predetermined water temperature.
- 7 A lifting mechanism adjusts the height of the oscillating grates to allow flexibility of firebox size and heat outputs according to needs.
- 8 Manual air inlet control.
- 9 Easily removed, double glazed, oven door to simplify cleaning.
- 10 Cleaning access.

- 11 Storage / Warming cupboard.
- 12 The side panels have highly efficient insulation.
- 13 Direct draught control.

**Fig. 3 - Front cross section**

82.916 : Control knob in heating position.  
 82.914 : Control knob in cooking position.

- 1 Water flow.
- 2 Water return.
- 3 Top plate shield (82.914).
- 4 Fire-brick (82.914).

**Fig. 4 - Side cross section**

- 1 Water flow.
- 2 Rear flue outlet.
- 3 Firebox grates.
- 4 Water return.
- 5 Ash pan.

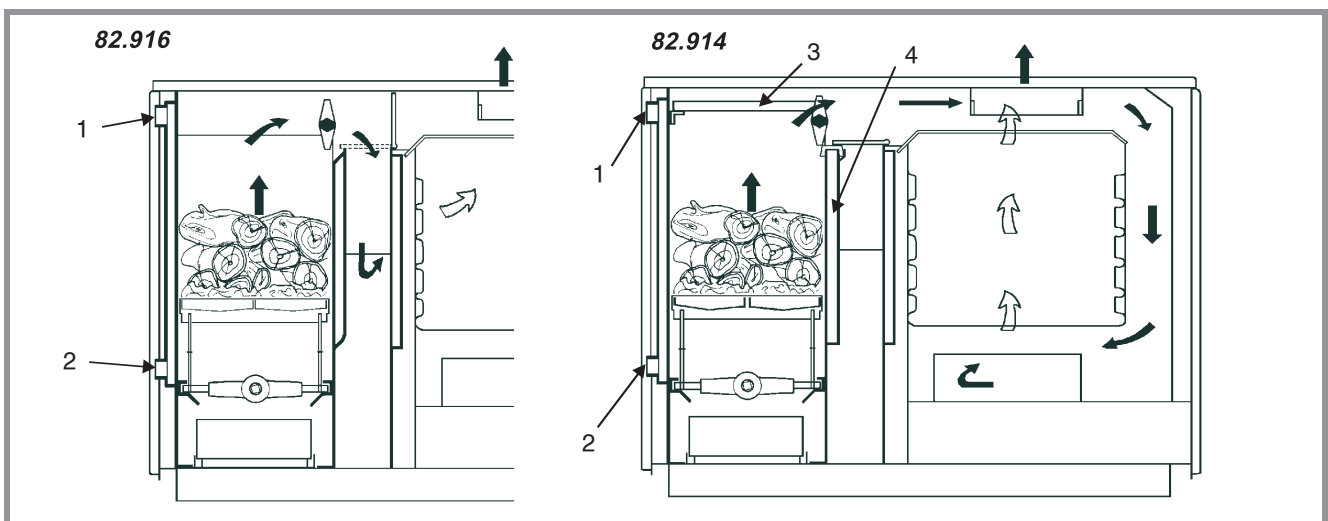

Fig. 3

## 2. Assembly and installation

Please read and understand thoroughly before commencing installation.

FRANCO-BELGE recommends that the installation of all their products is undertaken only by qualified heating engineers who are experienced in solid fuel heating.

The installation must be in accordance with current Building Regulations and Codes of Practice.

### 2.1. Positioning the cooker

The room in which the cooker is to be installed must satisfy all local regulations

These will stipulate an adequate fresh air inlet of at least 350 cm<sup>2</sup>. This must be situated in such a way, that in adverse wind conditions the air flow cannot be reversed as this may suck air out of the room in which the unit is installed.

- 6 Grate bar.
- 7 Secondary air inlet.
- 8 Thermostat.
- 9 Hole for riddling.
- 10 Primary air inlet
- 11 Threaded lifting bar
- 12 Top plate shield (82.914).

*Fig. 5 - Optional insulated covers*

- Rear fire outlet cover in 2 parts.
- Top flue outlet : cover in 3 parts.

- 1 Handles.
- 2 Hinges.

*Fig. 6 - Guard rail and fire box door handle*

- 1 Rail.
- 2 Firebox door handle.

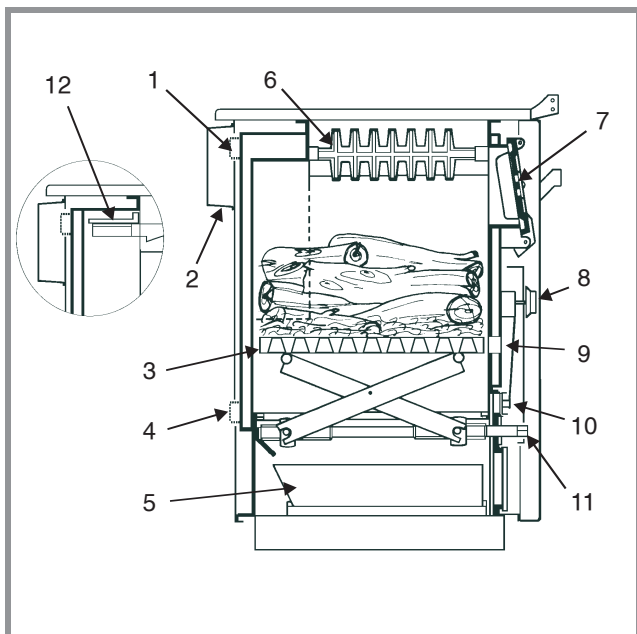

*Fig. 4*

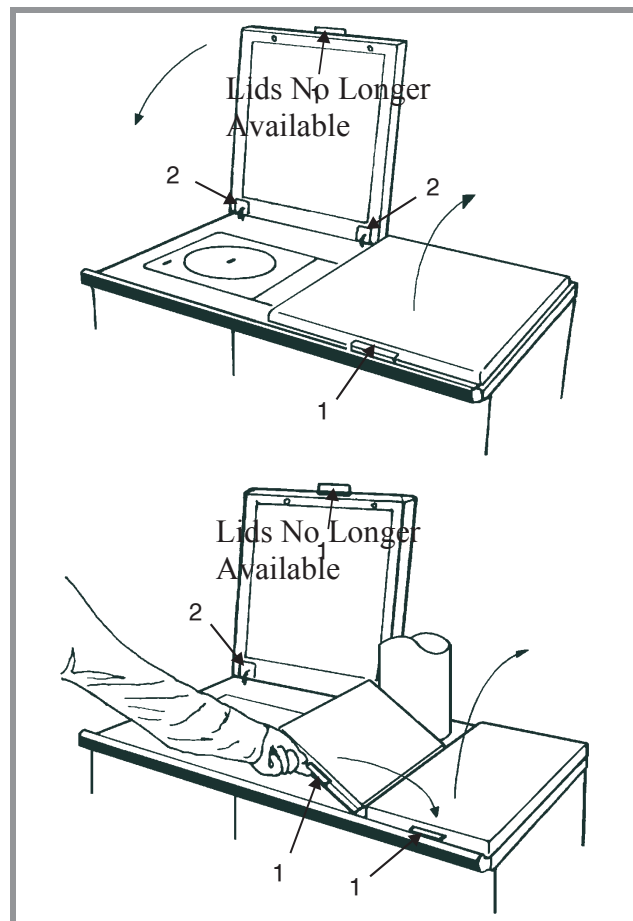

*Fig. 5*

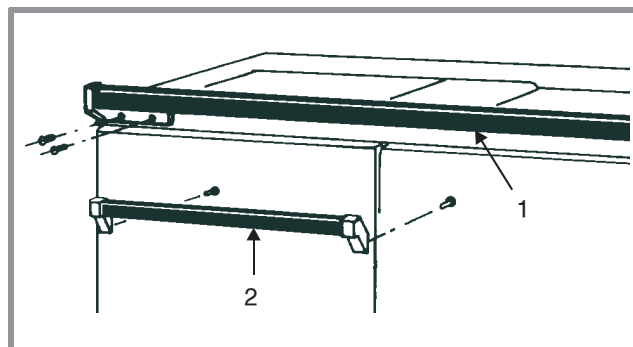

*Fig. 6*

### 2.2. Mounting

The guard rail, firebox and oven door handles are not fixed on the cooker to avoid damage during transit.

#### 2.2.1. Covers

Locate the lugs 2 (ill. 5) of the covers in the holes at the rear of the top plate. Fit the handles 1 on the covers.

#### 2.2.2. Guard rail and firebox door

Fit the guard rail and the firebox door handle with the screws supplied (ill. 6).

### 2.2.3. Lower oven compartment door

If required a handle for the lower oven compartment door is packed inside the unit.

### 2.2.4. Oven door handle

To fit the oven door handle :

- Remove the oven door **8** (ill. 7).
- Remove the two screws **1** (ill. 7) and hold the inner door **4** half open with a block **2**.
- Unscrew the struts **6**.
- Place the nuts **7** into the slot of the handle supports **5** et place the fiber washer **3** between the handle and the door.
- Centre the handle before screwing up the struts.
- Fit the inner oven door and replace the oven door.

## 2.3. The chimney

The chimney is the key to a successful installation and the following key areas should be checked.

### Height

The minimum height should be 5 metres with the terminal at least 1 metre from the roof surface and in a clear area away from possible downdraft. If in doubt always increase the chimney height. This will help to ensure an adequate draft and clearance of the flue gases from the area of the building.

### Insulation

The chimney needs to be warm from bottom to top and should be adequately insulated. Cold chimney and cool flue gas temperature will result in tar formation and smoke emission into the room.

### Resistance

If the chimney has a horizontal section at the appliance outlet, this should not exceed 30 cm. Any changes in direction should be gradual (15 degrees maximum) and the chimney system must not incorporate more than two bends. The straighter the chimney, the less resistance. Any resistance will slow down the flue gases and help to create a build up of tar deposits.

### Draft

The appliance requires a draft of between 04" and 07" W.G. to burn effectively. This is the up draft of air through the appliance. It is the result of the height of the chimney and heating of the column of air within the chimney. An inadequate draft will cause soot and tar formation in the chimney.

The appliance requires a class 1 chimney. Existing unlined chimneys should be lined with a liner suitable for use with solid fuel burning appliances. If there is no existing chimney, there are a variety of prefabricated systems available and it is recommended to discuss your particular application with a chimney specialist.

## 2.4. Connection to chimney.

### • TOP FLUE OUTLET

Use the draught control box (ill. 17).

The draught control box can be dismantled to give access for flue cleaning.

### • REAR FLUE OUTLET

It is not possible to use the draught control box in this position. Provision should therefore be made to fit a draught regulator.

**Important !** When the rear flue connection is used, cut

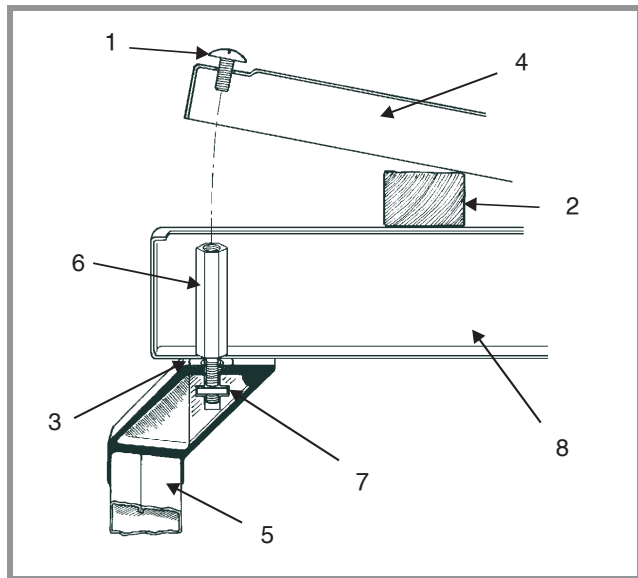

Fig. 7

Fig. 7 - To fit the oven door handle

- |   |                  |
|---|------------------|
| 1 | Screw.           |
| 2 | Block.           |
| 3 | Fibre washer.    |
| 4 | Inner oven door. |
| 5 | Handle.          |
| 6 | Strut.           |
| 7 | Nut.             |
| 8 | Oven door.       |

Don't forget to fit with an airtight seal the flue collar and the blanking plate which are supplied and packed in the firebox.

Caution : Sufficient access must always be left for chimney sweeping and appliance cleaning.

## 2.5. Connecting the central heating circuit.

In any installation, Relevant Building Codes and Practices must be observed.

- The appliance is not designed as a pressure vessel, so the circuit must be left open to the atmosphere and must not be constructed to allow any pressure build-up to occur (ill. 8).

- A gravity circuit **MUST** be provided, as a fail safe heat loss in the event of a circulating pump failure or a power cut. To achieve this, ensure that large diameter pipes leading to upstairs radiators have a direct flow from the boiler, or install a big hot water cylinder with large diameter heat exchanging coil, situated above the cooker.

The layout of the heating circuit can be designed in any fashion that suits the house, as the pump will ensure circulation of hot water to all points, but the hot water cylinder or a small heating circuit must be engineered to work by gravity. Use 1 inch min. I.D. pipe (28 mm) to the cylinder, ensure that the cylinder has a 314 inch min. I.D. coil wound from top to bottom, and that the inlet is above the boiler and the outlet is above the return tapping of the boiler.

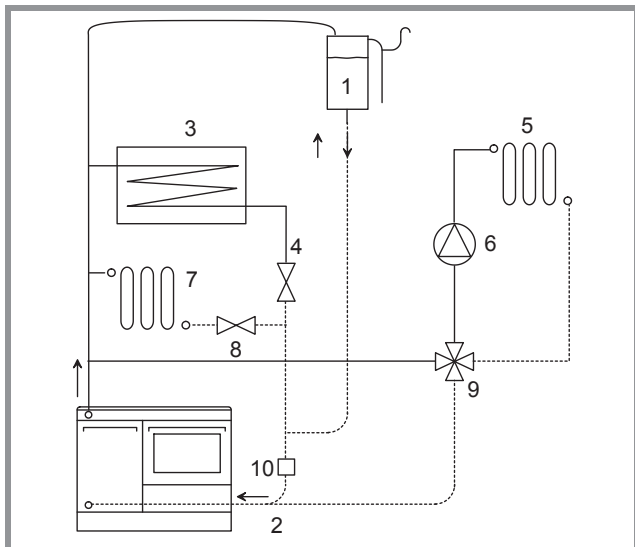

Fig. 8

**Fig. 8 - Example of installation**

Pumped central heating, gravity hot water system, four way mixing valve.

- 1 Expansion tank.
- 2 Sweep tee.
- 3 Water cylinder.
- 4 Adjustable non return valve.
- 5 Pumped central heating.
- 6 Circulating pump.
- 7 Gravity circuit.
- 8 Control valve.
- 9 Four way mixing valve.
- 10 Limit stat set to switch pump off if water return is less than 50°C.

• An expansion tank open to the atmosphere must be provided to ensure that no pressure build-up can occur, and this should be connected to the highest point of the circuit by 1" I.D. pipe (28 mm). If the system is going to be left unattended during winter periods, anti freeze should be added. In the case of an installation coupled to an automatic boiler, this should not be necessary.

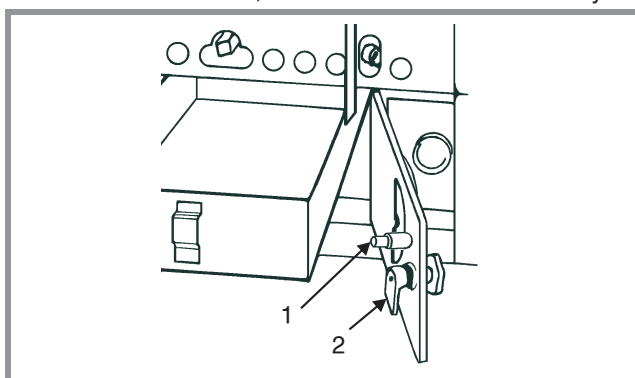

Fig. 9

**Adjustment of the ashpan door**  
1 - Stop 2 - Lever

N.B. This model has optional water tapping on the rear or the left hand side of the cooker. Ensure unused tapping are blanked off using the plugs supplied.

• **IMPORTANT** : In order to avoid condensation and low temperature corrosion of the water jacket, the return water temperature must not fall below 50°C. A four way mixing valve should be used but it must be fitted in such a way as to prevent the primary flow from being restricted.

In addition a thermostat should be fitted on the gravity return to switch the circulating pump off if the water temperature falls below 50°C.

## 2.6. Adjustments

### 2.6.1. Ashpan door (ill. 9)

Once the door seal has bedded in, it may be necessary to adjust the door to regain the airtight seal :

- Remove the stop **1**.
- Unscrew the lever **2**.
- Replace the stop **1**.

### 2.6.2. Thermostat (ill. 10)

If adjustment is necessary, this is done by altering the nut **2** on the lever arm.

- Remove the front protective panel by lifting it up.
- Then set the thermostat **1** in position "6".

When the water temperature reaches 60°C/146°F, the damper should be closed.

If adjustment is necessary turn the nut, anticlockwise to open the damper, clockwise to close the damper.

After adjustment, check that the water temperature is maintained at 60°C/146°F.

**Note to installer : Please ensure that the- se instructions are handed to the user upon completion of the installation.**

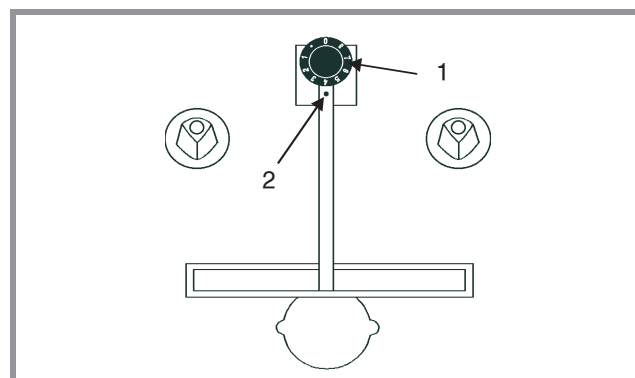

Fig. 10

**Thermostat setting**  
1 - Knob. 2 - Nut



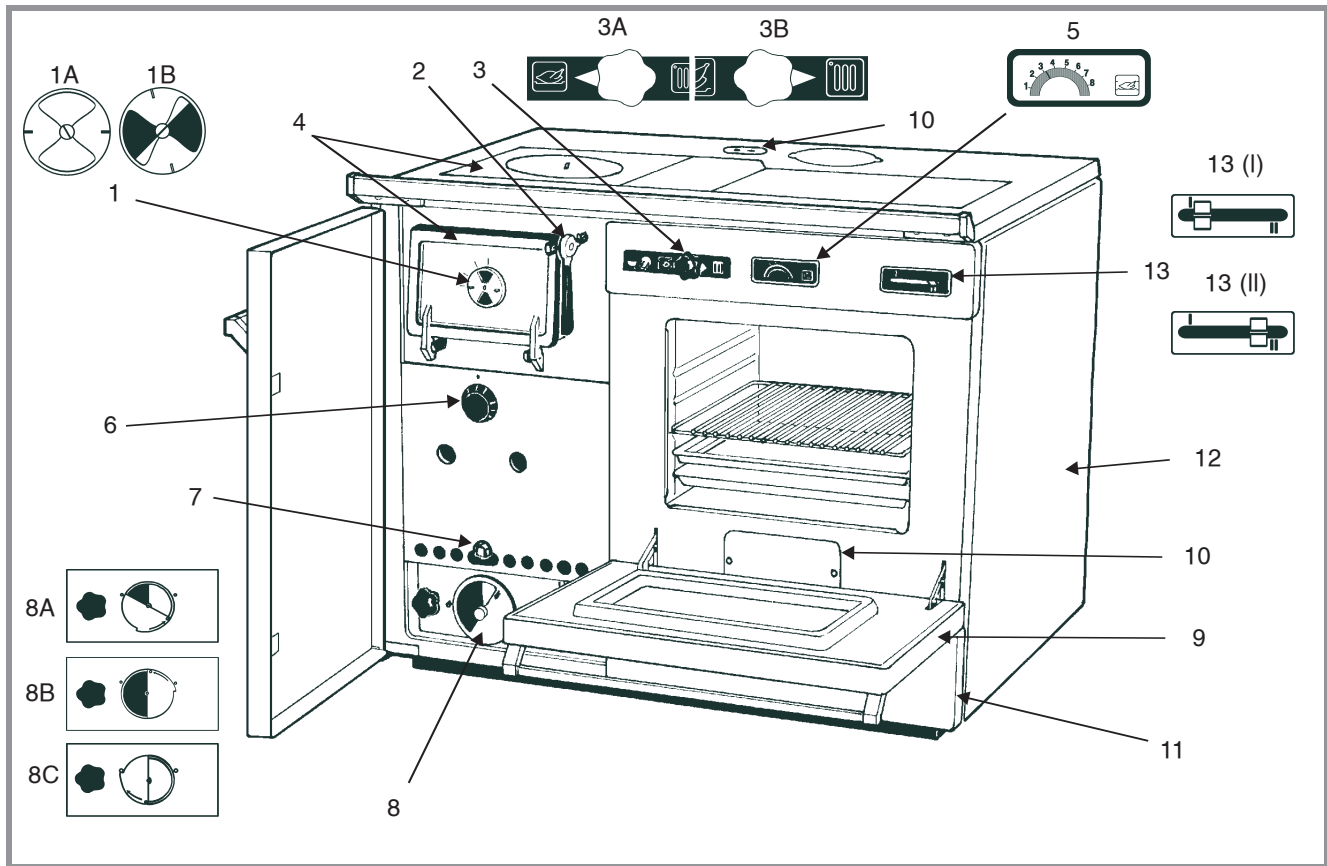

Fig. 11

**Fig. 11 - Operating description of the appliance**

- 1** Secondary air control :
  - 1A : Closed : When burning wood or smokeless fuels.
  - 1B : Open or half open : When burning solid fuel with high volatile contents (e.g. household coal, soft coal), the secondary air inlet allows a more complete combustion of the volatiles produced.
- 2** Handle and lock.
  - 3A : When the knob is turned to cooking and the firebox has been stoked, the hot plates and oven quickly heat up, without greatly affecting the temperature in the central heating circuit.
  - 3B : When the knob is turned to heating, most of the heat is absorbed by the heat exchanger and transferred to the central heating circuit.
- 4** Top or front loading. The firebox design allows solid fuel, wood or peat to be burned with equal efficiency and economy.
- 5** Thermometer

Position on the thermometer

1	2	3	4	5	6	7	8
180°F	230°F	320°F	420°F	600°F	760°F	920°F	1060°F

Average temperature in the middle of the oven

- 6** The thermostat automatically regulates the burning rate and helps to maintain a constant prede-termined water temperature.

Thermostat control on position

2	3	4	5	6	7	8
66°F	86°F	106°F	126°F	146°F	166°F	186°F

Water temperature

- 7** A lifting mechanism adjusts the height of the oscillating grates to allow flexibility of firebox size and heat outputs according to needs.
- 8** Manual air inlet control :
  - 8A and B: Open = Lighting, quick restoration of the fire.
  - 8C : Closed = normal.
- 9** Easily removed, double glazed, oven door to simplify cleaning.
- 10** Cleaning access.
- 11** Storage / Warming cupboard.
- 12** The side panels have highly efficient insulation.
- 13** Direct draught control :
  - 13 I : Direct draught flap open : The direct draught Control gives easier lighting and quick restoration of the fire.
  - 13 II : Closed = normal.

**Fig. 12 - Oscillating grates mechanism**

- 1** Oscillating grates.
- 2** Support grate.
- 3** Lifting handle.
- 4** Stainless steel screen.
- 5** Cast iron nut.
- 6** Lifting cradle.
- 7** Screw.

**Fig. 13 - Removable parts**

- 1** Top plate shield (82.914).
- 2** Grate bar.



## 3. Operating instructions

### 3.1. Checks prior to lighting

Before lighting the cooker, check the following points :

- The water circuit is filled and has been tested for leaks.
- The cleaning access traps are closed (access plate on top and front access trap below the oven door, and beside the ash pan door).
- All the grates are in their correct positions.
- The cooking/heating control knob and the direct draught flap move freely.
- The thermostat and its air inlet flap have been adjusted.
- All chimney seals are airtight and the draught control box mechanism is free.

### 3.2. Fuel

#### • Wood

In general any type of wood is suitable for use in a Franco-Belge as long as the fuel is seasoned for a minimum of 2 or 3 years and dried to a moisture content of less than 20 %.

Hard woods such as oak or elm burn steadily giving an

even heat over a relatively long period of time.

Soft woods such as pine release their heat very rapidly but their burning duration is very short. This makes soft woods ideal for initial lighting or when quick heating of the appliance is required (e.g. cooking or rapidly heating domestic hot water).

The importance of burning dry seasoned wood cannot be overstressed as wet fuel may lose up to 50 % of its possible heat value, resulting in inadequate central heating and slow unresponsive cooking ; together with rapid clogging of the flue-ways and chimney, which is dangerous and a fire hazard.

NOTE : Never burn wet or unseasoned wood.

#### • Peat

Same specifications as wood. The moisture content must be less than 20 %. Failing to respect the before mentioned points on seasoning fuel or moisture content will void the guarantee.

#### • Solid fuels

Household coal is relatively soft. This makes it an easy fuel to light which is responsive to air controlled regulation. The output, although greater than wood is low in comparison with other solid fuels. Whilst relatively cheap, the disadvantage with this fuel is its impurities which produce thick dense smoke which can quickly clog the flue ways and chimney, and frequent attention must be paid to keep them clean.

Smokeless fuels, such as Homefire, Coalite and Sunbright, are amongst the highest in heat value of solid fuels. Their hardness and density makes them more difficult to light and relatively slow in reacting to control by air regulation but the lack of impurities makes this type of fuel far cleaner and less attention has to be paid to the flueways and chimney.

If you are restricted to using smokeless fuels, they must have a long flame to allow quick response when cooking. Your local merchant should be able to assist you in choosing the most suitable fuel for your needs.

In general, most owners of Franco-Belge appliances find that by mixing their fuels, they will obtain the best results for their individual situation.

Trial and error will tell you which mixture of fuels works best for you. So please experiment with mixtures of small quantities before placing your bulk order.

NOTE : If using bituminous coal, it must be of good quality.

WARNING : When burning bituminous coal, care must be taken when opening the firebox for loading or inspecting the fire.

Coals disintegrating under heat and those producing large amounts of ashes are not recommended for use in these appliances.

### 3.3. Lighting

Place firelighters (or rolled newspaper and kindling wood) on the grates and place 2 or 3 small logs on top of firelighters.

- Set the thermostat in position "8".
  - Place the control knob **3** (fig. 11) in cooking position **3B**.
  - Open the direct draught flap **13 (I)**.
  - Open the manual air inlet control **8A**.
- Light the firelighters. Once the fire is burning well stoke up with fuel.
- Close the direct draught control **13 (II)**.

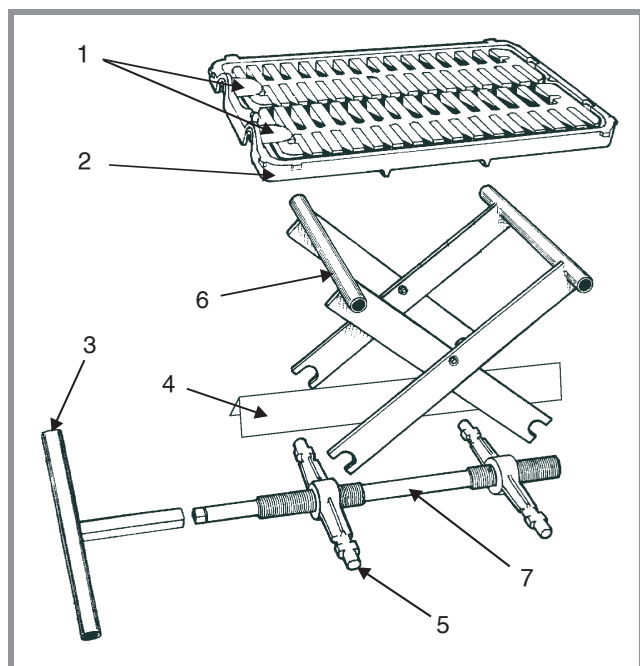

Fig. 12

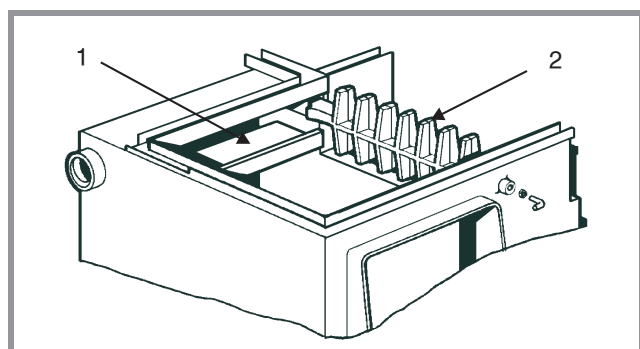

Fig. 13

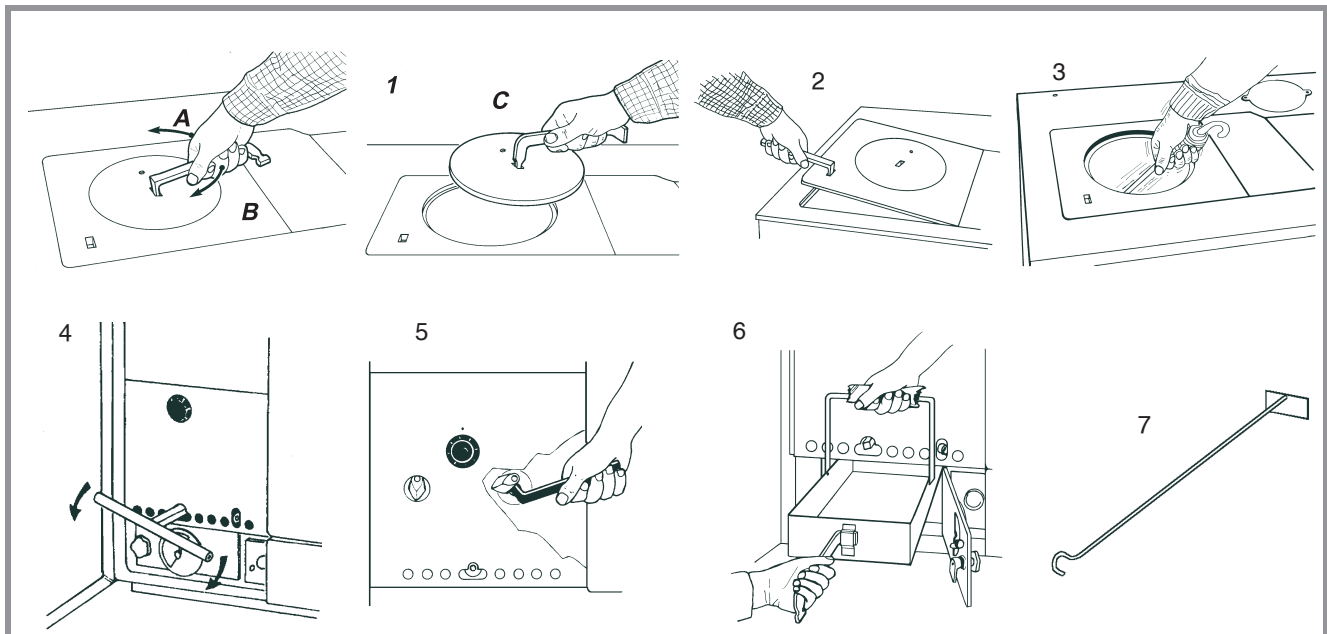

Fig. 14

**Fig. 14 - Operating tools**

- 1 For lifting and locking the loading lid :
  - 1A : Open.
  - 1B : Off.
  - 1C : Lifting (take the tool on the other side).
- 2 For raising the left inset plate above firebox.
- 3 Poker.
- 4 Adjustment of the height of the grates :
  - To lower the grates, turn anticlockwise.
  - To raise the grates, turn clockwise.
- 5 Riddling handle for de-ashing.
- 6 For handling ash pan.
- 7 Scraper for cleaning firebox and flue way.

- Close the manual air inlet control **8B**.
- Place the control knob in heating position **3A**.
- Set the thermostat.

CAUTION : Ashpan door must be closed during operation to prevent overfiring.

REMARK : Should a small quantity of black water appear as a result of condensation when the unit is first lit. Do not be concerned, close the 4 way valve and check that the low limit stat is set correctly.

As the system heats up, gradually open the 4 way valve. Should the problem persist, contact your installer to check the good working of the 4 way valve and low limit stat.

### 3.4. Operation

#### Lifting mechanism : (ill. 14, # 4)

Choose the height of the firebox grates according to the heating requirements of individual needs (see technical details).

If an intermediate output is required, place proportionally the grates on an intermediate level.

The adjustment of the height of the grates is done by turning the threaded lifting bar located on the front of the cooker.

Use the lifting handle on the threaded lifting bar to alter the grates

#### Secondary air control : (ill.11, #1)

Closed when burning wood or smokeless fuels.

Half open when loading and burning solid fuel with high volatile contents. If the chimney draught is slow, open the secondary air control more.

Experience will indicate correct setting.

#### Remarks about the use of fuels :

The amount of ash in the fire is a very important factor in the performance of the Franco-Belge.

When burning wood, a good base of ashes is advantageous for slow controlled burning, but should be reduced by riddling before cooking, or whenever ash accumulates too much and reduce the fire box capacity. When burning coal or smokeless fuels, the ash must be riddled more frequently to allow a good airflow to the fire. Coal and especially smokeless fuel requires much more air to burn than wood.

Guarantee: The use of unsuitable fuels will invalidate the guarantee.

#### Loading :

The cooker may be loaded through the top or the front. To obtain the best result and a long burning period, the firebox should be loaded with fuel to within 2" (5 cm) of the top of the right inside water jacket (or of the firebrick for 82.914).

NOTE : When burning solid fuel with high volatile contents, the firebox must not be loaded entirely. It is recommended to load it step by step to allow all the contents to be freely exhausted.

#### De-ashing :

The cooker may be de-ashed only when the oscillating grates are in the lowest position **4** (ill. 14).

Lower the firebox grates if necessary and slide the riddling handle into the front holes as shown **5** (ill. 14).

De-ash every morning and if required before each loa-

### 3.4.1. Heating regulation

#### Normal rate

- Close the ashpan door and the manual air inlet control **8B** (ill. 11).
- Place the control knob on heating position **3A**.
- Close the direct draught flap **13 (II)**.
- Set the thermostat control **6** between position "1" and "8".

Provided that the firebox is well stoked with fuel, the thermostat regulates the burning rate of the fire and produces the required temperature.

NOTE : After every long burning period, run the appliance hot for at least 30 minutes to remove any residual tar and moisture.

#### Slow burning

- Riddle grates in lower position.
- Closed the ashpan door and the manual air inlet control **8B**.
- Set the thermostat **6** on a low setting.

Note : If no central heating water is required :

- Raise the grates.
- Place the control knob on cooking position **3B**.
- Open the direct draught flap **13 (I)**.

Note : If heating is required :

- Place the control knob in heating position **3A**.
- Close the direct draught flap **13 (II)**.

Stoke up with fuel when burning rate is stabilized.

Set the mixing valve on a low position to maintain the temperature of return water at a minimum of 50°C.

#### Restoring the fire

- Riddle grates in lower position.
- Open the manual air inlet control **8A** .
- Rise thermostat setting to "8".
- Place the control knob on cooking position **3B**.
- Open the direct draught flap **13 (I)**.
- Stoke up with fuel.
- Close the manual air inlet control **8B**.
- Place the control knob on heating position **3A**.
- Close the direct draught control **13 (II)**.
- Set the thermostat.

### 3.4.2. Cooking regulation

1/2 hour before cooking :

- Riddle grates in lower position.
- Stoke up with fuel.
- Open the manual air inlet control **8A** .
- Place the control knob on cooking position **3B**.

#### • Hot plate cooking

If full use of the hot plate is required :

- Place the control knob on cooking position **3B**.
- Open the direct draught flap **13 (I)**.

This will allow the whole hot plate area to be heated without heating the oven.

IMPORTANT ! The direct draught lever must be returned to normal running position after use.

When the appliance is turned to central heating position, the area directly above the firebox will become hot enabling a kettle to be kept simmering.

When there is a low fire, the hot plate will heat quicker by raising the firebox grates to the top position.

When using the oven, the hot plate will in any case be ready for use.

#### • Oven

To heat the oven :

- Place the control knob on cooking position **3B**.
- Ensure that the direct draught flap is closed **13 (II)**.

The temperature of the oven can be seen from the thermometer on the front panel.

Regulation of the oven temperature is obtained by opening the manual air inlet control to decrease the temperature, or closing the manual air inlet control to increase the temperature.

NOTE : As with any solid fuel cooker, there is no substitute for experience, and with a little time and patience you will soon learn what controls are necessary.

#### • Summer use

Provided the installation has a large hot water cylinder and a heat leak radiator on gravity circulation, the appliance can be used for cooking and domestic water heating in summertime.

The grates should be raised to the top position to reduce the capacity of the firebox and the water heating output.

CAUTION :

Control lever must always be in cooking position **3B**.

If the cooker is not to be used for any length of time, it should be cleaned thoroughly, debris removed and the flue disconnected. This will ensure adequate ventilation and avoid sweating and associated problems.

All moving parts must be cleaned and lubricated to prevent seizure.

### 3.5. Flue draught control box

For Great Britain only (ill.17) :

The draught control box is designed to slow down the flow of gases leaving the appliance and entering the flue.

This is accomplished by restricting the square area of the chimney. It causes the gases created in the appliance to move slower and in so doing reduces the

Fig. 17 - Flue draught control box (Great Britain)

- 1 Spinner air wheel.
- 2 Damper control.

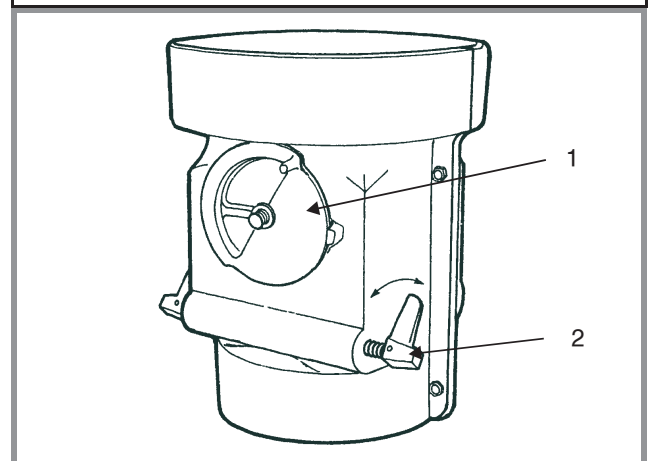

Fig. 15

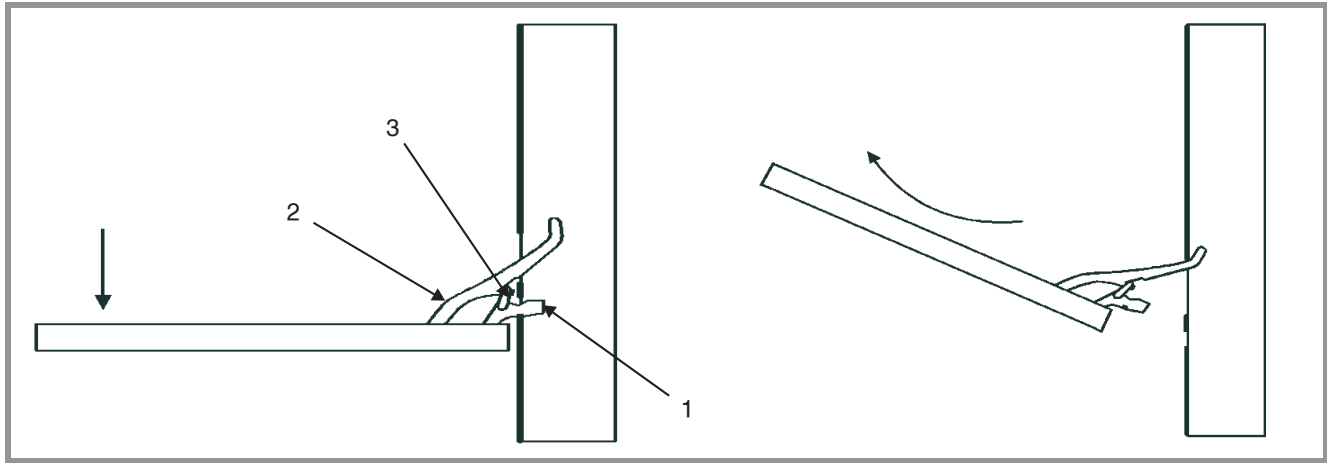

Fig. 16

amount of combustion air entering the unit. The result is that the appliance will burn for longer periods.

The flue box has two controls : the spinner air wheel **1** and the damper control **2**.

If it is found that the appliance is burning too fast, close the flue damper **2** to one of the four positions. Trial and error will determine which setting is best for your situation. When experimenting, start by putting the lever in the top position and close it notch by notch, as necessary.

Always remember to open the damper to a vertical position before attempting to reload with fuel.

The air wheel **1** situated at the front of the flue box should only be used if the damper gives insufficient control. If this is the case, the air wheel may be opened little by little until the desired result is obtained. The air wheel must not be used for long periods and should be closed before refuelling.

### 3.6. Maintenance

#### 3.6.1. Removing the oven door (fig.15)

- Open the door , press down on front edge.
- Lift up the small U brackets **3** on each of the hinges **1** and **2**.
- Lift the door and draw it out at the same time.

To replace it, reverse the procedure. Check the smooth working of the door.

#### 3.6.2. Lifting mechanism

At least every 6 months, clean and lubricate the threaded connections of the lifting mechanism (ill. 12 ).

- Lower the firebox grates to lowest position
- Remove the oscillating **1** and support grates **2**.
- Remove the stainless steel screen **4** and the support cradle **6**.
- Using a wire brush, clean the threaded lifting bar **7** and then lubricate the threaded section with the hot thread compound supplied (Ensure that the lubricant is fed into the roots of the thread).
- Replace the support cradle, screen and grates.

#### 3.6.3. Heat Exchanger And Flue Ways

The appliance is most efficient when all the surfaces of

#### Fig. 15 - Removing the oven door

- 1** Hinge.
- 2** Hinge.
- 3** Bracket.

#### Fig. 16 - Maintenance of the flue

Cleaning firebox and flue way.

tly clean. If soot and ashes are allowed to build up, this can pit the walls of the water-jacket and shorten its life. With this in mind, the following suggested maintenance schedule will help to keep your franco belge in good condition and at the peak of efficiency :

**Daily** : Run the cooker hot for at least 30 minutes (this will normally occur during cooking).

**Weekly**: If using wood, burn solid fuel once a week to help reduce any tar build up.

**Every 2nd week** : Using the scraper provided, scrape down the water jacket to clear any tar or soot build up.

**to 6 weeks** : Clean all flue-ways surrounding oven and water jacket. Ensure that all parts removed for cleaning are replaced properly.

**Every 6 months** : Have the chimney swept and don't forget the connecting flue pipe and draught control box.

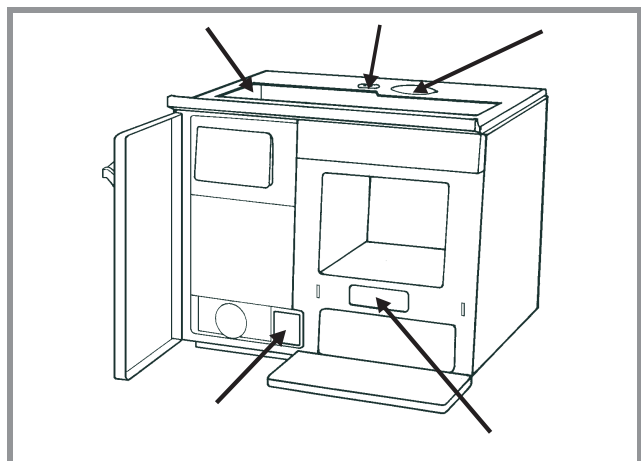

Fig. 17

## Trouble Shooting

Symptoms	Likely Cause										
	1	2	3	4	5	6	7	8	9	10	11
	Inadequate Draught	Excessive Draught	Draught too variable	Condensation	Insufficient air entering kitchen	Restriction In Flue	Fuel	Operator Error	Chimney Construction	Rate of Burning	Thermostat Failure
Difficulty in maintaining fire	•				•		•	•			•
Difficulty in obtaining oven temperature	•						•	•		•	
Unstable oven temperature		•	•					•		•	
Unresponsive fire	•						•				
Smoke and smell in kitchen	•				•	•					
Smoke emitted when loading	•					•					
Rapid sooting-up of chimney and flue ways	•						•		•	•	
Fire goes out overnight	•						•		•		
Fire burns out overnight		•									•
Uncontrollable burning rate			•						•		•
Difficulty in obtaining water temperature	•						•			•	•
Overnight burning performance dependent on weather conditions			•								
Smoke emitted when door is slammed					•						
Moisture in ashpan and under boiler				•							
Large amounts of clinker forming							•			•	

Increase the frequency of cleaning and servicing of the appliance to ensure efficient and trouble free running. If left unused for long periods (E.g. Summer months) clean the appliance thoroughly, disconnect flue pipe and block the chimney, leave all air inlets fully open. All hinges and pivots should be lubricated to prevent seizure.

### To clean the flue ways :

- Remove the oven door.
- Also remove the grates of the firebox.
- Use the scraper to clean all the inner walls (ill. 16).
- Remove the soot.

Serious damage will occur to the appliance if these precautions are not taken rendering the guarantee void.

**CAUTION :** Any abnormal smell of fumes must be reported at once to your installer. As a precaution, put the fire out until an examination has been made.

**De-ashing :** The cooker may be de-ashed only when the oscillating grates are in the lowest position. Lower the firebox grates if necessary and slide the riddling handle into the front holes as shown. De-ash every morning and if required before each loading of fuel. Remove ashes daily.

## 3.7. Fault diagnosis.

### 1 - Inadequate draught

The chimney should be checked with a draught meter and if below the recommended level, look for air leak or

If the connecting flue pipe terminates in a large chimney and no evidence of air leaks can be discovered, a chimney liner should be considered.

If the inadequate draught is due to a poor geographic position, consult your dealer to consider an electric draught inducing fan.

### 2 - Excessive draught

If top flue the cooker should have been supplied with a draught control box to help regulate the chimney draught. If the control box gives inadequate control, fit a draught stabiliser.

### 3 - Draught too variable

This could be caused by a cold chimney with excessive heat loss but it is more likely that the cause is turbulence at the chimney terminal.

Raise the height of the chimney or fit a suitable cowl.

### 4 - Condensation

Condensation is often mistaken for a leaking water jacket and can be very persistent. Each water jacket is tested thoroughly in the factory and it is highly unlikely that a leak could be the cause.

### Condensation is caused by :

- A poor chimney which allows the flue gases to condense on the chimney lining.
- Wet wood fuel being used. *Dry and season wood well before burning it. See section on fuels.*
- The return water temperature being too low. *To minimise the possibility of condensation, always allow your*



FRANCO-BELGE *to warm up slowly and never operate the circulating pump until the system is heating with the return temperature no more than 15°C below the flow temperature and in any case, no less than 50°C.*

If condensation still persists, allow the fire to burn slowly for a full 24 hour period heating the domestic hot water only. Then try the pump again.

If the return temperature is always 20°C below the flow temperature with the pump on, it is likely that the 4 way mixing valve is not being used correctly. This indicates that insufficient hot water is being directed into the return.

Condensation normally appears only when the system is first used and sometimes at the beginning of the winter season when the heating is first put on.

In both cases, allow the heat to build up very slowly and condensation will be kept to a minimum or not experienced at all.

Continual condensation will reduce the life of the water jacket and invalidate your guarantee. It should therefore be avoided at all costs.

If condensation occurs after the pump has been turned on, this will be due to the heating circuit cooling the system too quickly.

The solution is to switch off the pump, allow the system to reheat fully and turn on only half the radiators when the pump is switched on.

Gradually, turn on the remainder of the radiators, one by one, allowing plenty of time for the return water to keep up temperature.

#### **5 - Insufficient air entering kitchen**

See section, Positioning the appliance.

#### **6 - Restriction in flue**

Apparent if the appliance has normal flue draught and reaches temperature quickly but smokes when being loaded or when a large volume of air is admitted to the

The restriction may be a fall of soot or masonry in which case, chimney sweeping should cure the problem .

Alternatively, the problem may be caused by too many bends which are too acute in the chimney construction.

#### **7 - Fuels**

See section Fuels.

#### **8 - Operator error**

By this, we mean that it may be that you need a little more time to get used to your cooker.

However, if you still have problems after persisting for some time, please contact your dealer.

#### **9 - Chimney construction**

The chimney's construction must comply with Current Building Regulations.

An inadequately insulated chimney will allow rapid cooling of the flue gases, causing excessive deposits in the chimney which will lead to condensation and eventually smoke emission from the appliance.

#### **10 - Rate of burning**

All Franco-Belge appliances are designed to be efficient when burning slowly but they must be burned hot for 30 minutes after each slow burning period to prevent a residual build up of tar/soot in the flue ways (normally this would be achieved during cooking).

However, you must not operate your Franco-Belge at maximum output for excessively long periods.

#### **11 - Thermostat failure**

Whilst it is highly unlikely that the thermostat would fail, it is a possibility that should be investigated once the other likely causes have been looked into.

## 4. Spare parts

When ordering spare parts, specify the appliance type and serial number, including the colour index (on the guarantee or identification plate), the name of the part and the part number.

Example : Cooker, ref : **82.914 A**, Front panel **652566 QV**.

A = **82.914 A**    B = **82 914 B**  
C = **82 916 A**    D = **82 916 B**

N°	Code	Description	Type	A	B	C	D	
0	135090	Lubricant compound		A	B	C	D	1
1	911900	Water jacket		A	B			1
1	911901	Water jacket				C	D	1
2	309927	60 Main door		A	B	C	D	1
2	981600	Main door		A	B	C	D	1
3	314605	60 Inner panel		A	B	C	D	1
4	181602	Ceramic rope	Ø 8	A	B	C	D	3,90 m
5	158542	Handle		A	B	C	D	1
6	100954	Axle		A	B	C	D	1
7	110402	Hinge pin	6x30	A	B	C	D	4
8	301713	60 Air damper		A	B	C	D	1
9	166003	Spring	11x15	A	B	C	D	2
10	189103	Screw	27x8x6	A	B	C	D	2
13	179010	Thermostat		A	B	C	D	1
14	261802	Heat shield		A	B	C	D	1
15	320605	60 Sliding door		A	B	C	D	2
16	325301	60 Reducing plate		A	B	C	D	1
17	305913	60 Access cover		A	B	C	D	1
18	142335	Gasket	105x105x3	A	B	C	D	1
19	105104	Nut		A	B	C	D	2
20	300806	60 Frame		A	B	C	D	1
21	301139	60 Ash pan door		A	B	C	D	1
21	988801	Complete door		A	B	C	D	1
22	301711	60 Air damper		A	B	C	D	1
23	446300	Knob		A	B	C	D	1
24	301509	Door lock		A	B	C	D	1
25	134750	Pin	4x26	A	B	C	D	2
26	100905	Axle		A	B	C	D	1
27	326700	Flue guard		A	B			1
27	326701	Flue guard				C	D	1
28	105221	Firebrick		A	B			1
30	157522	Insulated plate		A	B			1
31	321002	Firebrick fixation		A	B			1
32	302726	Top plate shield		A	B			1
40	319705	Grate support		A	B	C	D	1
41	306714	Oscillating grate		A	B	C	D	2
42	867700	60 Cross piece		A	B	C	D	2
43	100951	Axle		A	B	C	D	2
44	208300	Screen		A	B	C	D	1
45	922700	Cast iron nut		A	B	C	D	1
46	922701	Cast iron nut		A	B	C	D	1
47	189114	Threaded lifting bar		A	B	C	D	1
48	134757	Pin		A	B	C	D	2
50	302193	Top plate		A	B	C	D	1
50	702113	80 Top plate		A	B	C	D	1
51	302414	Top plate		A	B	C	D	1
52	302524	Removable top plate		A	B	C	D	1
53	302226	Removable top plate		A	B	C	D	1
54	189118	Screw	Ø 10	A	B	C	D	1
55	303617	Top plate		A	B	C	D	1
56	303819	60 Flue collar		A	B	C	D	1
57	303714	Blanking plate		A	B	C	D	1
59	302604	Access cover		A	B	C	D	1
60	211900	Clamp		A	B	C	D	2
61	132750	Tight hinge support		A	B	C	D	3
62	132751	Hinge support		A	B	C	D	2
63	164558	Decorativr bar		A	B	C	D	1
64	325002	60 Trim support		A	B	C	D	1
65	324902	60 Trim support		A	B	C	D	1
66	100940	Axle		A	B	C	D	4
67	273206	60 Hinge		A	B	C	D	1
68	273406	60 Hinge		A	B	C	D	1
69	273508	60 Hinge		A	B	C	D	2
70	652566	45 Front panel			B		D	1
70	652566	QV Front panel		A		C		1
71	134304	Striking plate		A	B	C	D	2
72	122807	Name plate		A	B	C	D	1
73	158761	Handle		A	B	C	D	1
76	207833	25 R. side panel		A		C		1
76	207833	30 R. side panel			B		D	1
77	228000	Square		A	B	C	D	4
78	207755	25 L. side panel		A		C		1
78	207755	30 L. side panel			B		D	1
79	208802	Inner panel		A	B	C	D	1
80	204145	Back panel		A	B	C	D	1
81	237402	Reducing plate		A	B	C	D	2



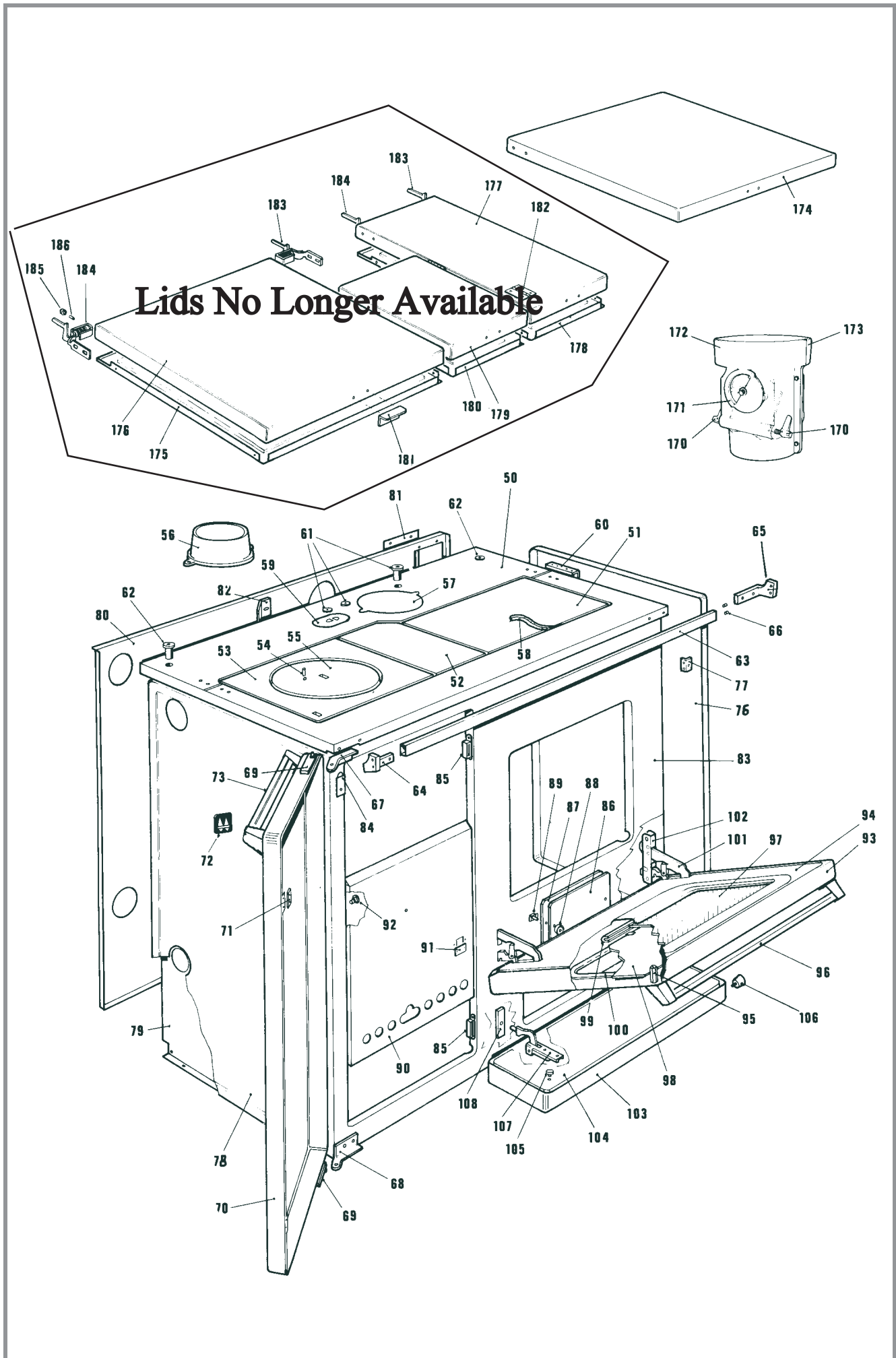

82	204201	Supplementary plate	A	B	C	D	1
83	200331	20 Front plate	A	B	C	D	1
84	228904	60 Square	A	B	C	D	1
85	101013	Magnetic catch	A	B	C	D	2
86	266602	20 Access cover	A	B	C	D	1
87	427001	Gasket	A	B	C	D	1
88	105118	Nut	A	B	C	D	2
89	190004	Captive screw	A	B	C	D	2
90	200707	20 Inner front panel	A	B	C	D	1
91	236106	20 Sealing plate	A	B	C	D	1
92	100902	Axle	A	B	C	D	6
93	647519	28 Oven panel	A		C		1
93	647519	30 Oven panel		B		D	1
94	647614	20 Inner panel	A	B	C	D	1
95	124454	Strut	A	B	C	D	2
96	158760	Handle	A	B	C	D	1
97	137155	Refractory glass	A	B	C	D	1
98	137154	Glass	A	B	C	D	1
99	142303	Joint	A	B	C	D	1,45 m
100	142306	Adhesiverope	A	B	C	D	0,64 m
101	109847	Hinge	A	B	C	D	2
102	109844	Hinge	A	B	C	D	2
103	249100	28 Warming drawer panel	A		C		1
103	249100	30 Warming drawer panel		B		D	1
104	249200	10 Inner panel	A	B	C	D	1
105	105501	Block stop	A	B	C	D	2
106	158603	Handle	A	B	C	D	1
107	909814	Hinge	A	B	C	D	2
108	451009	Stiffening plate	A	B	C	D	2
109	200114	Base	A	B	C	D	1
110	202301	Ash pan guide	A	B	C	D	2
111	200422	10 Plinth	A	B	C	D	2
112	624029	Ash-pan	A	B	C	D	1
113	400207	60 Ash pan handle	A	B	C	D	1
114	232804	Ash guide	A	B	C	D	1
115	639000	Warming drawer top	A	B	C	D	1
116	233008	Soot guide	A	B	C	D	1
117	446205	Protection plate	A	B	C	D	1
118	446206	Protection plate	A	B	C	D	1
119	222505	Flue baffle	A	B	C	D	1
120	691021	20 Oven	A	B	C	D	1
121	134915	Wire rack	A	B	C	D	1
122	218805	Baking tray	A	B	C	D	1
123	218904	20 Baking dish	A	B	C	D	1
124	308881	Oven top	A	B	C	D	1
125	313807	Supplementary panel	A	B	C	D	1
126	446207	Protection plate	A	B	C	D	1
127	209700	Screen	A	B	C	D	1
128	205503	Strut	A	B	C	D	1
129	208403	Heat shield	A	B	C	D	1
130	446200	Protection plate	A	B		C D	1
131	446201	Protection plate	A	B	C	D	1
132	607500	Oven back panel	A	B	C	D	1
133	446203	Protection plate	A	B	C	D	1
134	608700	Inner panel	A	B	C	D	1
135	208104	Heat shield	A	B	C	D	1
136	446202	Protection plate	A	B	C	D	1
137	446208	Protection plate	A	B	C	D	1
138	446204	Protection plate	A	B	C	D	1
139	209305	Suppl. heat shield	A	B	C	D	1
140	653381	30 Top panel		B		D	1
140	653381	35 Top panel	A		C		1
141	100602	Snap clip	A	B	C	D	4
142	134505	Push clip	A	B	C	D	4
143	123461	Trim	A	B	C	D	1
144	178607	Thermometer	A	B	C	D	1
145	177034	Dash board	A	B	C	D	1
147	105114	Knob	A	B	C	D	1
148	460007	Regulator shaft	A	B	C	D	1
149	301288	Driving bar	A	B	C	D	1
150	324602	Driving bar	A	B	C	D	1
151	100943	Bolt	A	B	C	D	2
152	325701	Flue door	A	B	C	D	1
153	313301	Hinge	A	B	C	D	2
154	400012	Axle	A	B	C	D	2
155	304509	Frame	A	B	C	D	1
156	304615	Direct draught door	A	B	C	D	1
157	134702	Pin	A	B	C	D	2
158	462415	Direct draught rod	A	B	C	D	1
159	236905	60 Driving bar	A	B	C	D	1
160	231301	Square	A	B	C	D	1
161	100939	Axle	A	B	C	D	3
162	105115	Knob	A	B	C	D	2
163	179911	Thread rod	A	B	C	D	2
164	813100	60 Lifting handle	A	B	C	D	1
165	312803	60 Hand tool	A	B	C	D	1
166	858003	60 Scraper	A	B	C	D	1
167	180002	Poker	A	B	C	D	1

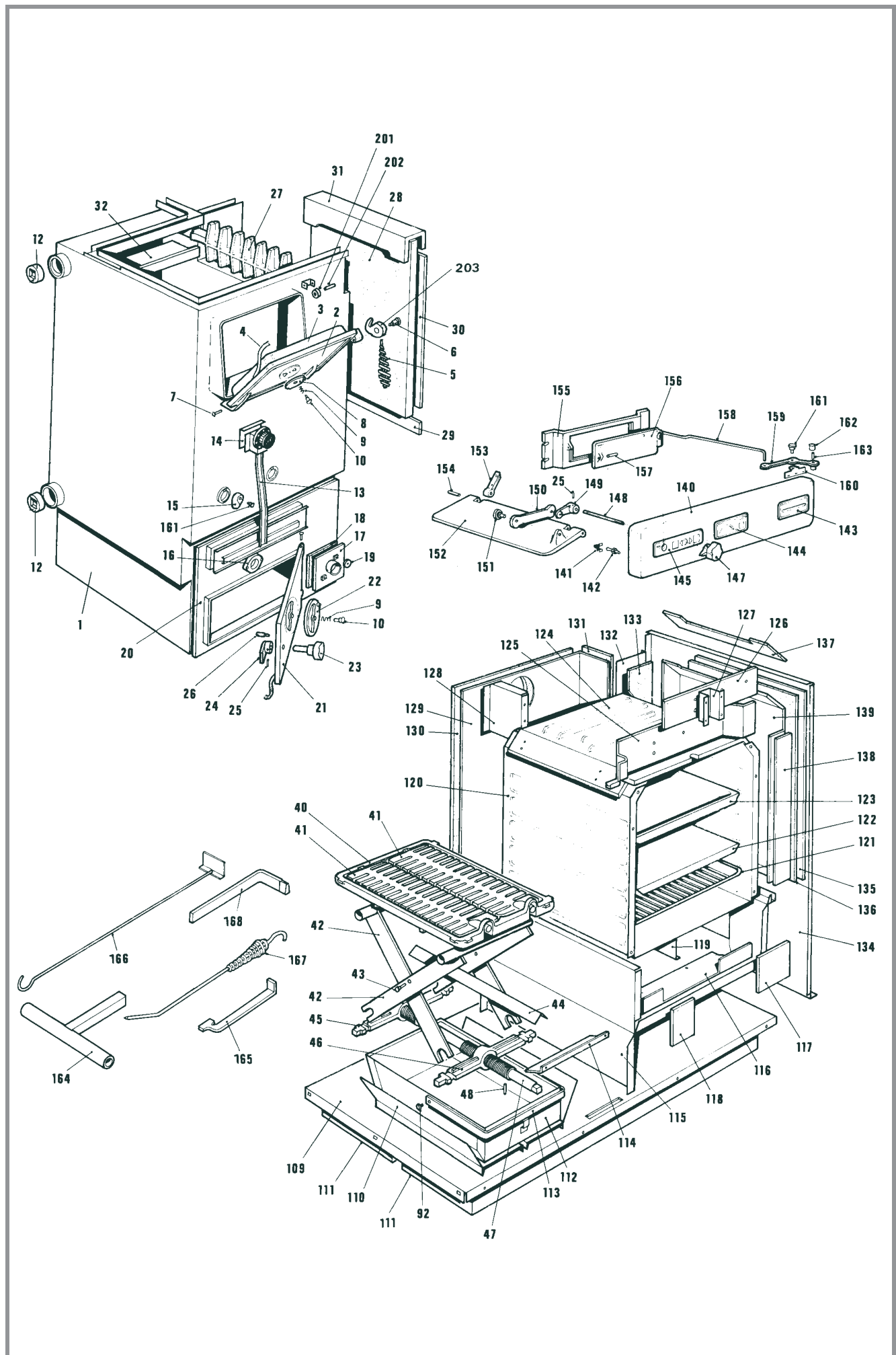

168	154801	Operating tool	A	B	C	D	1	
170	301506	60 Door lock	A	B	C	D	2	
171	301731	91 Air damper	A	B	C	D	1	
172	905103	Half box with wheel	A	B	C	D	1	
173	326001	91 Half box	A	B	C	D	1	
174	652604	25 Cover	A		C		1	
174	652604	30 Cover		B		D	1	
175	254520	20 Supplementary cover	A	B	C	D	2/1	
176	652738	25 Cover	A		C		1	
176	652738	30 Cover		B		D	1	
177	652605	25 Cover	A		C		1	
177	652605	30 Cover		B		D	1	
178	254701	20 Inner cover	A	B	C	D	1	
179	252801	25 Cover	A		C		1	
179	252801	30 Cover		B		D	1	
180	254801	20 Inner cover	A	B	C	D	1	
181	158540	Handle	A	B	C	D	3/2	
182	109826	Hinge	A	B	C	D	2	
183	109825	Hinge	A	B	C	D	2	
184	109824	Hinge	A	B	C	D	2	
185	122303	Capnut	A	B	C	D	4	
186	189108	Screw	5X8	A	B	C	D	4
201	134252	Bushing	A	B	C	D	1	
202	134701	Pin	5x24	A	B	C	D	1
203	301518	60 Door lock	A	B	C	D	1	



## ♣ Warranty certificate ♣

### ♣ Legal warranty

Our products are guaranteed for twelve months against any defect, flaw or imperfection. During this time, all parts judged defective by our Warranty control department may be replaced in our workshops. Incidental costs of transportation and packing payable by the buyer.

Some parts or components have a longer warranty period :

- Cast-iron shell of boiler : 3 years
- Steel shell of boiler : 3 years
- Removable or independent stainless steel hot water cylinder : 5 years
- Independent enamelled steel hot water cylinder : 3 years
- Incorporated circulating pump : 2 years.

### ♣ Terms of the warranty

This warranty is only valid if :

- The unit has been installed and checked by a professional installer before operating,

- All installation and adjustment instructions listed in the technical manual supplied with the unit have been followed,
- All operation and maintenance instructions have been followed.

### **This warranty does not cover :**

- Lamps, fuses, spark plugs, cast iron parts directly in contact with burning coal and wood, firebricks, glasses .
- Any damage resulting from the use of fuel not recommended in our instructions ;
- Parts which are damaged by external causes such as unadapted chimneys, thunderstorms, damp, faulty pressure or fail in pressure, thermic anomalies, explosions, etc...
- Electrical parts which are deteriorated by any connection or use on a supply circuit with voltage within 10% of the indicted voltage (230 V).

Material subject to modifications without prior notice. This manual does not engage the responsibility of FRANCO BELGE.

Name and address of installer : _____	
_____	
( Telephone :	_____
* Name and address of customer :	_____
_____	
Date of installation :	____ / ____ / ____
Model of the appliance : q	82 914    θ    82 916
Couleur : θ	A    θ    B
N° de série / Serial number :	_____
<p style="text-align: center;">This certificate has to be completed and kept carefully. In case of claims, send a copy of this to :</p> <p style="text-align: center;"><b>Les Fonderies Franco-Belges, rue Orphé e Variscotte, 59660 MERVILLE, FRANCE.</b></p>	