

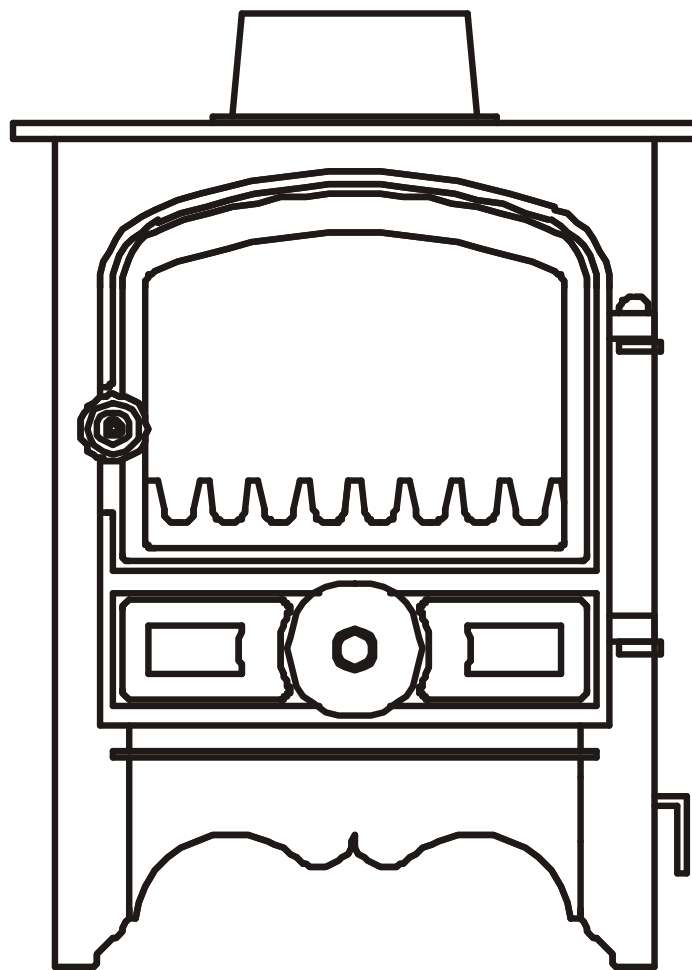

**BUBBLE 1 MARINE OIL STOVE ©
USER INSTRUCTIONS**

ISSUE 4 @10-09-13



INDEX

WARNINGS.....	4
INTRODUCTION.....	4
FIREGUARDING.....	4
DOOR GLASS.....	4
STOVE EXTERIOR.....	5
BURNER POT.....	5
FASTENING DOWN.....	5
HOW IT WORKS.....	5
CONTROLS.....	5
THE OPTIONAL COAL KIT.....	6
STOVE COMPONENTS.....	6
RUNNING THE STOVE.....	6
OIL CONTROL VALVE DETAILS.....	6
LIGHTING AND ADJUSTING.....	7
TWO WAYS TO LIGHT THE STOVE.....	7
LIGHTING INTO THE BASE OF THE POT.....	7
MANUAL LIGHTING THROUGH THE LIGHTING PORT.....	7
EXCESS FLAMES DURING IGNITION.....	8
CORRECT LOW FIRE RUNNING.....	8
CORRECT HIGH FIRE RUNNING.....	8
NEVER TRY TO RELIGHT A HOT STOVE.....	8
EXTINGUISHING THE STOVE.....	8
FUEL SUPPLY INFORMATION.....	8
FUEL GAUGE.....	8
ISOLATION VALVE.....	8
FUEL FILTER.....	8
SAFETY SHUT OFF VALVE.....	8
ISOLATION VALVE.....	8
FLOODED POT.....	8
STOVES WITH BOILERS.....	8
FAULT FINDING.....	9
CHIMNEY PROBLEMS.....	9
DOWNDRAFTING.....	9
ATMOSPHERICS.....	9
SUMMARY OF CHIMNEY PROBLEMS.....	9
CHIMNEY HEIGHTS.....	10
MINIMUM HEIGHT FOR LOW FIRE RUNNING.....	10
FUEL SUPPLY PROBLEMS.....	10
WAXING.....	10
CHANGING OIL PRESSURE AT THE STOVE.....	10
POOR OIL FLOW PROBLEMS.....	10
OIL FEED SET UP.....	10
OIL LINE.....	11
WATER CONTAMINATION.....	11
RACING.....	11
FLUE VACUUM.....	11
BURNER SHUTS DOWN AND STOVE GOES OUT.....	11

OIL TRIP WILL NOT RESET	12
BURNER WILL NOT COME TO HIGH FIRE	12
OIL WILL NOT FLOW INTO THE POT	12
OIL SMELLS	12
BURNER RUNS SOOTY.....	12
BURNER DOES NOT LIGHT EASILY	12
OIL WILL NOT ENTER THE POT	12
OIL SMELLS	13
DEFLOODING A FLOODED POT	13
OIL LEAKS.....	13
FAULT FINDING HEATING SYSTEM	14
THE CIRCUIT DESIGN.....	14
AIR LOCKED CIRCULATING PUMP.....	14
AIR LOCKED SYSTEM PIPEWORK.....	14
INADEQUATE SYSTEM PRESSURE HEAD.....	14
INOPERATIVE CIRCULATING PUMP.....	14
INADEQUATE PIPE SIZEING.....	14
INADEQUATE CALORIFYER DESIGN.....	14
INADEQUATE STOVE LOCATION.....	14
FLOW OF WATER THROUGH THE BOILER.....	14
FLOW OF WATER THROUGH THE CALORIFYER.....	14
FLOW OF WATER THROUGH THE RADIATORS.....	14
THE SYSTEM IS NOT OVER PUMPING.....	14
LACK OF SAFETY VALVES.....	14
FEED AND EXPANSION (IS IT FITTED IN THE CORRECT PLACE.).....	14
ROUTINE MAINTENANCE	14
EVERY 4 WEEKS:	14
EVERY 8 WEEKS:	14
EVERY 24 WEEKS:	14
EVERY 12 MONTHS:	14
EVERY 24 MONTHS:.....	14
AS REQUIRED:.....	14
WARRANTY	14
ITEMS NOT COVERED BY WARRANTY	14
PARTS LIST	15

WARNINGS

1. Never try to relight a hot stove; wait until it has cooled down, hot oil vapour is explosive.
2. Never try to light a flooded pot, when attempting to light a stove make sure that the pot is not flooded with oil, by looking into the base of the burner.
3. If it is flooded remove the excess oil as per instructions in the fault finding section.
4. The stove must not be operated with the glass front door opened or cracked, or without the lighting port plug fitted.
5. Do not attempt to clean the stove door glass whilst the glass is hot, make sure that the glass is completely cool before cleaning.

INTRODUCTION

The stove is a heating unit which burns diesel oil in a controlled manner utilizing a chimney to discharge the products of combustion.

It will provide space or combined space and water heating and is designed to be used on inland waterways craft.

There are three versions of the stove.

Space heating only.

Space heating and a small boiler.

Space heating and a large boiler.

On the boiler versions there are 2 x 1" BSP female sockets for water connections to be made.

Both boilers are high water content and suitable for pumped or gravity systems, pressurised or open vented systems, provided that the systems are correctly designed.

The stove incorporates a removable front apron, which is used to gain access for lighting after first opening the front door.

On the right hand, lower side of the stove is a small lever which should be rotated occasionally to descale the oil inlet pipe.

The stove must be securely bolted down so that it can resist impact or collision and it must be level in both directions.

The top of the stove can be used for warming and cooking providing that a suitable fiddle rail is fitted to the top of the stove.

The stove can also be supplied with or without a coal kit.

Just like a solid fuel stove, coal effect will only be available when the stove is running at maximum or near maximum performance which is 4kW OR 14,000 B.T.U, s PER HOUR.

There are components in the stove which will need replacing from time to time and these are -:

Upper catalyser (Burner component)

Lower catalyser (Burner component)

Flame ring (Burner component)

Descaling device packings. (This device is located where the oil flow pipe goes into the burner pot)

Door glass.

Door glass seals.

Door rope seals.

There are components in the oil supply line which need to be kept in good condition and serviced annually

For spacing from combustible materials the stove must be treated in the same way as a SOLID FUEL APPLIANCE and as such, whilst it is running, will become very hot and must not be touched.

For safe distances from combustible materials see the information contained in the Installer Literature.

FIREGUARDING.

To prevent the risk of injury through burning a suitable fireguard must be fitted and adequate provision made for guarding the exposed flue pipe where a potential danger is presented.

DOOR GLASS.

The door glass will require light cleaning occasionally and the frequency of cleaning will depend upon how often the stove is used.

Where stoves are ignited each day then the glass may soot up as the lighting process may generate a little soot until the stove has settled down into blue flame combustion.

Where stoves are running continuously then the glass will need cleaning less frequently but when cleaning is required you will need to let the stove go out and completely cool down

Use a soft cloth and slightly damp it with vinegar or a proprietary stove glass cleaner

After cleaning wipe it dry.

STOVE EXTERIOR

To clean the stove externally

Let it go out and simply brush away any dust with a very soft brush.

To clean the stove internally, use a soft brush to remove any dust or combustion debris into a vacuum cleaner hose.

BURNER POT

Occasionally scrape away any hard carbon deposits from the bottom of the burner pot and remove debris with a vacuum cleaner.

FASTENING DOWN.

7. The stove must be securely fastened down so that it can resist impact or collision and it must be level in both directions.

HOW IT WORKS

The stove generates heat from burning oil mixed with air in a vaporizing pot located in the bottom of the stove.

Once lit, oil goes into the pot at a steady and controlled rate via gravity flow, metered by the OIL CONTROL VALVE the oil flow can be controlled from minimum to maximum or any setting in between determined by where you set the oil flow control knob.

Air is sucked into the pot by the natural action of the negative pressure in the chimney and to allow the chimney to work correctly it is essential that you have adequate, unrestricted ventilation into the area where the stove is situated.

The amount of oil that can be successfully burned is directly proportional to the amount of air that the chimney can draw into the pot and so to achieve adequate combustion a balanced and appropriate flow of both oil and air is required.

As stated earlier, the air side of the equation can vary wildly with the changing performance of the chimney and so to compensate for this the appliance has a built in, combustion air restrictor, designed to maintain a steady and constant supply of combustion air to the burner.

The flow of oil into the pot can be adjusted via the knob on top of extension rod rising up from the oil control valve.

With the increased flow of oil, extra heat is generated, which in turn stimulates the chimney to work harder and consequently draw more air into the pot to maintain an adequate fuel air ratio.

CONTROLS

The output of the stove is regulated by the amount of oil allowed to go into it and this function is controlled by the -:

OIL CONTROL VALVE (O.C.V.), which is situated at the rear, right hand side of the stove.

Turning the knob anti clockwise controls the oil flow. The knob is located at the top right hand side of the stove and is calibrated from off position (fully clockwise) through 6 graduations to maximum.

Controls for the stove will vary, depending on which valve is fitted to it.

The valve could be a ships valve or a Toby valve.

The control for the dry stove comprises-:

Oil flow control only.

Oil valve trip lever

The boiler version has extra controls which are-:

Oil flow control

Oil valve trip lever

Thermostat control

Safety Stat reset control

The Toby oil control valve used on boiler stoves has a built in, non electric, modulating thermostat control, which will put the fire on to low fire when the target temperature has been achieved.

In addition to this there is also a similar safety stat, which will shut the burner down, should the water exceed 80 deg C.

The safety stat re set control is lifted to reset the valve, should the stat trip. Details of this are provided in the valve booklet supplied with the stove.

The Toby valve has to be tripped into action by lifting the trip button at the left hand side of the control panel.

The flow of oil into the pot can be adjusted via the larger knob on top of the extension rod rising up from the oil control valve.

LIGHTING.

WARNING FOR BOILER STOVES.

If the stove is fitted with a boiler, air locks or poor

water flow through it may cause damage.

Make sure that the boiler has been vented of all air BEFORE ATTEMPTING TO LIGHT THE STOVE.

Lighting the stove takes a little time and patience; the following procedure should be adopted.

Open the front door.

Remove the coal kit if it has been supplied with the stove.

Remove the inner catalysers and burning ring.

Turn the oil on at full rate and allow oil to flow into the bottom of the pot to form a pool about the size of a small digestive biscuit and then turn the oil off.

Do not allow any depth of oil to build up in the base of the pot.

Light a small piece of firelighter (about the size of a pineapple chunk) and place it into the centre of the pot.

Replace the lower burning ring, the mesh catalyser and the coal kit and then leave the door slightly open whilst the firelighter gets the oil going.

After 30 to 40 seconds, you will notice the flame start to establish itself and spread around the bottom of the pot.

When this occurs, close the door and turn the oil on to its minimum setting.

After two or three minutes the flame should then slowly change from yellow into blue flame combustion and settle down to a steady burn.

Note there may be the occasional growl or audible vibration whilst the burner settles down into blue flame combustion.

Allow the burner 10 - 15 minutes to stabilise and the increase the flow of oil as required, moving by one increment of the dial only.

Do not leave the appliance unattended during the lighting and stabilising procedure.

THE OPTIONAL COAL KIT

The coals are located on the coal support bars, which are designed to glow red in the flame, passing on the incandescence into the coals.

The front fret is designed to allow incandescent glow and flicker through to add to the effect.

Care must be taken when positioning the coals on the spikes.

The whole system is designed so that it can be removed in its entirety without the need to disturb

the coals making routine leaning and servicing very easy.

To remove it, turn the stove off and when it is cooled down, undo the front door knob, open the door and lift it out using the front fret.

Take care not to drop any coals into the pot.

STOVE COMPONENTS

The stove has the following components, which can be removed for cleaning or servicing.

The front door can be opened beneath which is a small apron covering the front of the burner pot.

The apron can be lifted off to reveal access to the lighting port cover.

The inner burner components generally consisting of a burner ring, upper catalyser and lower catalyser.

On the lower right hand side of the stove is the descaling device lever.

This lever is used for descaling carbon build up from the inside of the oil inlet connection.

This lever should be rotated occasionally to clean away any carbon build up.

The descaling device has a gland packing nut which must be tightened occasionally to stop oil fume leak. The sealing gland will need to be replaced every second year.

NOTE WELL

The descaling lever must not be touched whilst the stove is running, it gets very hot and if touched will cause burns.

RUNNING THE STOVE

We use different valves on dry stoves as opposed to stoves with boilers.

We supply the appropriate literature packed in each stove for the oil control valve which is fitted to your stove.

You must familiarise yourself with all aspects of control detailed within this booklet.

OIL CONTROL VALVE DETAILS

1. The output of the stove is regulated by the amount of oil allowed to go into it and this function is controlled by the:

OIL CONTROL VALVE (O.C.V.), which is situated at the right hand side of the stove, behind the right hand side panel.

On dry stoves the oil flow is controlled by turning the knob anti clockwise from its off position.

The knob is located at the top right hand side of the stove and is calibrated from off position (fully clockwise) through 6 graduations to maximum.

It is possible to fit different makes of oil control valves to Bubble Stoves, make sure that you have the relevant separate valve document and that you are fully familiar with the operation of the particular valve which is fitted to your stove.

LIGHTING AND ADJUSTING

TOBY VALVES

When attempting to light the stove these are the **rules, which must be followed.**

Always make sure that the pot is not flooded with oil by looking down into the base of the pot.

Never try to light the stove if it is flooded with oil.

Do not light the stove and then leave it unattended, until it is settled down and stabilized into blue flame combustion on low fire.

(This will take approximately 10 minutes.)

TWO WAYS TO LIGHT THE STOVE

Through the lighting port.

Through the front door, directly into the base of the pot.

LIGHTING INTO THE BASE OF THE POT

Always make sure that the pot is not flooded with oil.

On the first light up you may find the first option easier, as you can see the oil trickle in to the pot more easily.

You must use a heatproof glove when putting the catalysers back into the pot and it is important to replace them quickly whilst the flame is small.

Make sure that the oil is turned off and make sure that the oil safety cut off knob is lifted (tripped on) via an audible click, *if there is no click then the valve will be in a cocked on state.* **LIFTING THE TRIP APPLIES TO TOBY VALVES**

Open the front door.

Carefully remove the coal kit,

Remove the upper catalyser and ring,

Remove the lower catalyser,

Turn the oil on and allow a small pool of oil to flow into the pot about the size of a small biscuit, **and then turn the oil off**

Light a small piece of firelighter and drop it into the oil, replace the catalysers and coal kit, and close the door.

Wait for approx 1 minute until the pool of oil is alight and then **turn the oil on** to minimum setting no 1.

Watch the appliance for a few minutes and you will see the flame establish and settle down into blue flame combustion.

Allow the burner to run for a further 10 minutes before turning the appliance up to the higher settings.

If at any time during the ignition process large amounts of flame can be seen, turn the oil off immediately and wait until the flames die down before putting the oil on again at minimum setting.

MANUAL LIGHTING THROUGH THE LIGHTING PORT

Always make sure that the pot is not flooded with oil.

Make sure that the oil is turned off and make sure that the oil safety cut off knob is lifted (tripped on) via an audible click, *if there is no click then the valve will be in a cocked on state.*

Open the front door.

Remove the lighting port plug by pulling it out of its tubular socket.

Turn the oil on to the first position via the flow control knob and allow a small pool of oil to flow into the pot about the size of a small biscuit.

TURN THE OIL OFF.

Cut a small piece of firelighter and stab it onto the spike.

Light it and push it into the lighting port tube, let the firelighter drop off the spike into the bottom of the pot.

Replace the lighting port plug back into the tube and close the cover.

Close the front door.

Wait for approx 1 minute until the pool of oil is alight and then **turn the oil on** to minimum setting no 1.

Watch the appliance for a few minutes until it settles down into blue flame combustion.

Allow the burner to run for a further 10 minutes before turning the appliance up to the higher settings.

If at any time during the ignition process large amounts of flame can be seen, turn the oil off immediately and wait until they die down before putting the oil on again.

EXCESS FLAMES DURING IGNITION

If at any time during the ignition process large amounts of flame can be seen, turn the oil off immediately and wait until they die down before putting the oil on again.

When the burner has been running for ten to fifteen minutes move the oil flow control knob round to position 3 and leave for another ten minutes after which it will be safe to run the burner up to full output.

CORRECT LOW FIRE RUNNING

When the burner is running correctly on position 1 (LOW FIRE) the lower catalyser will be glowing dull red.

Keep an eye on the low fire and if a dirty yellow flame can be seen, call back your service man to re adjust the oil flow.

CORRECT HIGH FIRE RUNNING

On full output, after approximately ten minutes, the coals should begin to glow red and there should be wispy blue flames licking through them.

To get the maximum effect the stove will need to be left for half an hour or so, if there are a lot of yellow flames call back your service man to re adjust the oil flow, a few yellow flames are acceptable.

Excess oil flow, poor flue vacuum, bad coal positioning or bad lighting technique can all contribute to rapid sooting of the glass and coals.

NEVER TRY TO RELIGHT A HOT STOVE

NEVER TRY TO RELIGHT A HOT BURNER, MAKE SURE THAT THE BURNER IS COMPLETELY COOLED DOWN BEFORE RE LIGHTING.

EXTINGUISHING THE STOVE

Shutting the burner off is a very simple manoeuvre.

Turn the oil flow control knob FULLY in a clockwise direction until you feel it stop in its off position.

After a few minutes, the flame will die down and eventually extinguish itself.

DO NOT TOUCH THE STOVE UNTIL IT HAS COMPLETELY COOLED DOWN.

NEVER TRY TO RE LIGHT A HOT BURNER, MAKE SURE THAT THE BURNER IS COMPLETELY COOLED DOWN BEFORE RE LIGHTING.

FUEL SUPPLY INFORMATION

Your Fuel is stored in an oil tank, which should incorporate the following features.

FUEL GAUGE

A fuel gauge, which can be in the form of a numbered circular dial or a site glass into which oil is fed so as to indicate the amount of oil in the tank.

ISOLATION VALVE

A manually operated isolation valve on the tank, usually a gate valve.

FUEL FILTER

A fuel filter, to filter out any small particles of dirt or contamination, which may get into the oil or tank.

SAFETY SHUT OFF VALVE

An automatically operated safety valve designed to shut off the oil supply should a fire occur near to the stove.

ISOLATION VALVE

A manually operated isolation valve near to the stove to allow you or the service man to turn the oil off should the need arise.

If you allow the stove to run the oil tank dry it will obviously go out.

Before filling the fuel tank you must make sure that the oil valve is tripped to its off position, otherwise the pot will flood.

FLOODED POT

If the pot floods do not attempt to light the stove until the excess oil has been removed from it.

STOVES WITH BOILERS

1. Stoves with hot water boilers are run in exactly the same way as stoves without.

There are extra controls, which are detailed in the oil valve booklet supplied with the stove.

FAULT FINDING

CHIMNEY PROBLEMS

The fitting of any appliance, solid fuel, wood or oil burning, requiring a naturally generated chimney vacuum, into a traditional narrow boat creates specific problems, which are mainly concerned with flues amongst other things.

Normally when fitting stoves into houses or bungalows although there are many problems, generally if the chimney comes out of the highest point of the property (normally the ridge of the highest roof) stoves will work well in most normal cases.

With boats the two major problems are -:

They move

By the nature of their shape, must have relatively low chimneys.

Whilst on the move the boat will travel through a variety of changing countryside which will have a dramatic effect on the atmospheric at the chimney terminal.

An example of this would be the transition of a boat down through a lock where the wind conditions at the outlet of the chimney will change dramatically as the boat descends into the lock to the lower water levels, severe down draught could occur.

Great care must be followed with chimneys on boats and it is critical to observe the following instructions.

To try and ensure satisfactory performance from the BUBBLE stove chimneys must be capable of maintaining a constant steady vacuum of not less than .04" Water Gauge when running on the high fire position and not less than .02" Water gauge when running on the low fire position; **at all times and in all terminal conditions.**

This obviously means that it is essential to fit a suitable anti down draft device to the terminal of the chimney.

Anti down draft terminals come in a variety of designs and it may be that trials will have to be made using more than one design to establish which of the different designs is more suitable to deal with a particular problem.

The chimney vacuum is directly proportional to the following factors:

The height of the chimney.

The resistance of the chimney. (Bends. terminals. etc.)

The cross sectional area of the chimney (diameter)

The Flue gas temperature.

The availability of replenishment air (ventilation)

The integrity of the chimney (does it leak)

DOWNDRAFTING

The contents of the chimney are equal to a cylinder of hot air which depending upon its temperature and volume wants to move vertically, with some force.

Stopping it moving vertically. are resistance such as:

Smoothness of internal wall of chimney.

Chimney bends.

Chimney terminals.

Lack of ventilation. (Air going out must be replaced by air coming in).

ATMOSPHERICS.

Atmospheric conditions at the chimney terminal that could be affected by where the boat is moored.

The boat is moored in a position near to high buildings, high trees or higher surrounding land and downdrafting is occurring.

This can be a serious problem, if there are any of the above in the immediate location (within 100 -200 yards) of the boat.

Under changing and fluctuating wind conditions downdragting will occur.

If you have to moor in situations where the above-mentioned criteria exist, and the stove is running, you must let it go out and wait until the offending wind conditions die down before re lighting the appliance.

Don't leave the appliance running and unattended.

Don't leave the appliance in running overnight.

SUMMARY OF CHIMNEY PROBLEMS

Hot air in large volumes = plenty of chimney pull.
(Vacuum)

Cold air in small volumes = little chimney pull.

Bends and chimney terminals create resistance to hot air flow thus reducing potential maximum chimney vacuum.

Because it is not possible to use high chimneys it is critical to observe the following instructions.

The chimney system must be designed so as to be easily extendible.

The chimney can have a minimum inside diameter of 90mm.

Outside the boat, the chimney should be twin wall and insulated to keep the flue gasses as hot as possible.

The chimney and stove must be adequately guarded to prevent the risk of injury through burning.

When moored extend the chimney if you want the appliance to be run at its maximum output, if you are happy with the output of the stove running at up to setting 3, then it will not be necessary to add the chimney extension.

The chimney terminal must be fitted with a terminal that will resist down drafting in all terminal conditions.

CHIMNEY HEIGHTS.

MINIMUM HEIGHT FOR HIGH FIRE RUNNING IS 2.2 METRES (long extension)

When cruising reduce the chimney height and turn the stove down to match the reduced chimney height.

Do not cruise with the stove turned up on full output.

MINIMUM HEIGHT FOR LOW FIRE RUNNING

MINIMUM HEIGHT FOR LOW FIRE RUNNING IS 1.8 METERS. (Short extension)

When mooring pay particular attention to the surroundings and remember that close objects such as high buildings, trees or adjacent walls may well cause down or up draughting.

Typical flue set ups can be seen in the illustrations showing the flue pipe fitting into a standard cast iron deck flange topped of with a traditional twin wall chimney, terminating with a rotating cowl.

FUEL SUPPLY PROBLEMS

There are several problems relating to fuel supply of which you need be informed.

WAXING - TRIM - ROLL

WAXING

Diesel has a nasty habit of waxing up when the temperature gets down to or lower than freezing,

This waxing or thickening alters its flow characteristics and consequently what was an adequate fuel feed supply can rapidly turn into an inadequate one when the temperature starts to fall.

The worst scenario is fuel feed pipe 50-60 feet long in 8mm dia. pipe.

The best-case scenario is a fuel pipe 4 feet long in 15mm dia with good insulated lagging.

CHANGING OIL PRESSURE AT THE STOVE.

Because of the layout of a boat it is not possible to provide a high pressure oil supply, in most cases a pressure head of out 18" is all that is available and as the tank empties this head of pressure will reduce, and may alter the flow characteristics of the fuel.

In some cases this head can also be affected by the ballast or trim of the boat, the changing level of the boat due to addition removal of ballast, fuel or water can have an effect on the position of the oil tank in relation to the stove and the angle at which the oil line is established.

Take great care to monitor all the effects of the different ballast and trim possibilities.

Make sure that adequate oil feed is always available at the outlet end of the fuel pipe before it enters the oil control valve at the stove.

POOR OIL FLOW PROBLEMS.

Bubble stoves have a very accurate oil flow control valve, which is set up to give a precise oil flow at high and low fire.

For example the stove is flow rated at 4cc per minute on low fire and 10cc per minute on high fire.

The test flow through the supply pipe should be well in excess of the maximum flow rate of 10ccs even when the temperature is below freezing and the boat is adversely trimmed.

OIL FEED SET UP.

If the stove is fitted forward at the bow end of the boat, to keep the oil feed supply as short as possible; a forward mounted oil tank is recommended.

The tank should have insulating material around it for protection from the effects of cold weather.

Always add a suitable proprietary antifreeze additive to the stove fuel for wintertime running, your fuel supplier should be able to advise you about fuel additives.

The tank should have conveniently sized filler and it must be vented.

The tank should have:

An isolation valve before an easily replaceable cartridge filter.

OIL LINE

The oil feed line starts after the fuel filter and proceeds to the point of entry, where the oil line goes into the cab of the boat, at this point there will be a remote sensing fire valve which is designed to do two jobs:-

Shut off the oil supply should a fire occur near to the stove. (Fire safety valve)

Shut off the oil supply should the flame be blown out. (Flame failure device)

This valve has a reset button, which allows you to re-cock the valve should it trip off.

The fire valve has a capillary tube on the end of which is a temperature sensitive phial; the phial is fitted into suitable pipe clips, near to the bottom of the stove.

The sensing phial should be positioned so that if downdrafting occurs, hot air flowing out of the burner will heat up the phial and trip the remote sensing valve, automatically closing down the fuel supply to the appliance.

In this case the valve is acting as a flame failure device.

The oil control valve also acts as a further safety device in as much as it cuts off the supply of fuel after a flame out.

If the bubble stove is fitted up to the first bulkhead the isolation valve may well be fitted outside the cabin or saloon of the boat and you should make sure that you know where it is and how to operate it.

Because of the high risk of fuel contamination with water, we strongly recommend the fitting of a high volume water trap in the oil supply line.

If there is a water trap fitted, make sure that you are fully familiar with its operation and service requirements.

In case of emergencies, a suitable and serviceable fire extinguisher should always be readily accessible near to the appliance.

WATER CONTAMINATION

A major problem on boats is water contaminated fuel.

Because of changing temperature, condensation droplets can build up on the inside of the fuel tank.

These droplets along with other sources of water contamination can cause a serious problem if not attended to.

Always keep an eye out for water in the oil.

Make sure that you check the filter bowl regularly.

If your stove is fitted with a Toby DVR oil control valve, it can be drained off without removal from the appliance.

The small drain screw is located at the bottom of the valve.

RACING

Audible vibrations generated by the flame caused allowing by too much oil in the pot, too quickly.

Turn off the oil flow until the burner has settled down to a steady burn rate and then turn the fuel on again but don't let the flame go out otherwise the burner **MUST** be allowed to cool down fully before a re-ignition is attempted.

FLUE VACUUM

The pot type burner is extremely sensitive to flue vacuum variations.

Good combustion will not be possible unless our instructions on chimneys and flue vacuum are followed.

If the burner does not burn with a blue flame, recheck the chimney vacuum and oil flow rate.

If the burner does not run well check that the seals in the stove are good and that there is no ingress of air into the appliance flue ways.

Check that the correct fuel oil is being used.

Check the levels.

BURNER SHUTS DOWN AND STOVE GOES OUT

- Oil tank empty
- Oil in tank at low level.
- Water temperature safety stat shut down. (Optional equipment)
- Secondary float chamber in oil control valve flooded
- Safety trip button accidentally caught and tripped off.
- Fire valve tripped off.

- Damaged oil feed pipe.
- Height of oil control valve has been disturbed.

OIL TRIP WILL NOT RESET

- Water temperature safety stat shut down.
- Secondary float chamber in oil control valve flooded. (Call serviceman)

BURNER WILL NOT COME TO HIGH FIRE

- Water temperature has reached the required setting and is under the control of the thermostat. (Optional equipment)
- Oil in storage tank is low or about to run out.
- Height of oil control valve has been disturbed.

OIL WILL NOT FLOW INTO THE POT

- Oil tank empty
- Water temperature safety stat shut down. (Optional equipment)
- Secondary float chamber in oil control valve flooded.
- Safety trip button accidentally caught and tripped off.
- Fire valve tripped off.
- Damaged oil feed pipe.
- Height of oil control valve has been disturbed.

OIL SMELLS

Generally slight oil leaks in the appliance may only be noticed when the appliance is turned off, as the oil vapour will normally be drawn into the appliance and vented off through the chimney.

Do not attempt to light the appliance if there is any trace of oil smell near or around the appliance.

If the appliance is running and there is an oil smell, turn the appliance off and investigate or call a service engineer.

The descaling device has adjustable packing, which may need to be tightened up after first undoing the lock nut

If this does not work then you will need to replace the gland packing, which is available as a service item from your supplier.

BURNER RUNS SOOTY.

Comments made on this subject assume that the appliance has been running normally for some time.

If the stove soot's up this indicates that there is not adequate air for blue flame combustion or there is an excess of fuel.

Check that the chimney is working correctly. (This means pulling enough air into the burner to allow correct blue flame combustion to occur.

Check that the fuel is the correct type and quality.

Check that the flow rates are correct.

Where burners are incorrectly installed and are allowed to run at high fuel flow rates on low chimney vacuums, long unsatisfactory yellow flame combustion and bad sooting will occur.

To rectify this problem call your service engineer.

Never switch from low settings straight up to high settings, a longer burner life will be achieved if the oil flow control knob is moved only by one number at a time leaving approx. two minutes between each setting change.

BURNER DOES NOT LIGHT EASILY

Read the instructions in the lighting section of this publication.

OIL WILL NOT ENTER THE POT

All stoves

1. Is there oil in the fuel tank?
2. Has the fire valve tripped?
3. Has the isolation valve been accidentally turned off?
4. Is the oil turned on at the oil flow control knob on the valve?
6. Is the oil feed pipe from the valve to the pot blocked? (Unlikely)

(STOVES WITH BOILERS)

Has the oil trip lever tripped off?

Has the boiler stat tripped off?

Operating oil flow rates

OIL Flow rates in cc per minute.

min	max
-----	-----

4cc	10cc
-----	------

Oil Flow Rates In litres per hour.

.24 litres	.6 litres
------------	-----------

Oil Flow Rates In litres Per 24 hours.

5.76 litres	14.4 litre
-------------	------------

Oil Flow Rates In litres Per 7 x 24 hours.

40.32 litres	100.8 litres
--------------	--------------

To achieve optimum burner performance at these flow rates you will need to have matching flue vacuums as stated.

OIL SMELLS

Visual check on all joints for obvious leaks.

Check that the descaling lever packing gland nut is adjusted.

DEFLOODING A FLOODED POT

If the stove is blown out by severe down drafting oil will run into the pot to a depth of approx 15mm and then stop. If this has occurred do not attempt to light the pot until it has been de flooded.

To carry out this procedure you will need:

A small, leak proof plastic bag.

A small sponge.

A larger plastic bag for disposal of the residue.

A pair of disposable plastic gloves.

Put a small plastic bag into the stove and sponge from the pot into the bag, when the excess oil has been removed put the plastic bag and sponge into another plastic bag and dispose of it.

OIL LEAKS

If the stove has blown out, flooded oil should not leak from the pot, if it has leaked into the drip tray it will have come from the descaling seal or the boat could have been subject to heavy movement causing the oil

to splash around and leak through the air holes in the side of the pot.

FAULT FINDING HEATING SYSTEM

If the system does not perform well check the following-:

THE CIRCUIT DESIGN.

AIR LOCKED CIRCULATING PUMP.

AIR LOCKED SYSTEM PIPEWORK.

INADEQUATE SYSTEM PRESSURE HEAD.

INOPERATIVE CIRCULATING PUMP.

INADEQUATE PIPE SIZEING.

INADEQUATE CALORIFYER DESIGN.

INADEQUATE STOVE LOCATION.

The stove is fitted out of level, allowing an air pocket to build up in the top of the boiler, causing subsequent kettling and damage to thermostat sensing phial.

FLOW OF WATER THROUGH THE BOILER.

FLOW OF WATER THROUGH THE CALORIFYER.

FLOW OF WATER THROUGH THE RADIATORS.

THE SYSTEM IS NOT OVER PUMPING.

LACK OF SAFETY VALVES.

FEED AND EXPANSION (IS IT FITTED IN THE

CORRECT PLACE.)

ROUTINE MAINTENANCE

EVERY 4 WEEKS:

Operate the descaling lever by turning it completely two or three times.

Clean inside of door glass.

EVERY 8 WEEKS:

Clean the burner completely by removing all the inner components as follows,

Open the front door via the circular brass knob.

Remove the optional coal kit if it has been supplied with the stove.

Remove the inner catalysers and flame ring.

Scrape the bottom of the pot clean and remove all carbon build up.

Reassemble in the reverse order.

EVERY 24 WEEKS:

Tighten up the gland nut on the descaling device to stop oil smells.

EVERY 12 MONTHS:

Have your service man replace or clean all the filters in the oil supply line.

EVERY 24 MONTHS:

Have your service man clean out the filter and check the function of all the safety equipment associated with the stove, oil supply and plumbing system.

Remove and clean out the oil supply pipe from the valve to the pot.

AS REQUIRED:

Keep the Coals, Coal kit, and burner inners in good condition, replace as necessary.

WARRANTY

Fill in the warranty form and returned it to us, the information recorded on the warranty form helps us to deal with any problems you may encounter.

Where we do not hold returned warranty forms replacement parts would only be issued when we are sure that the appliance has not been damaged by improper use or installation.

The warranty covers PARTS ONLY for a period of ONE YEAR from the date of purchase and is conditional upon all the requirements of our installation instructions being fully adhered to.

ARRANGE FOR SERVICE visits with a service engineer.

COPYRIGHT HARWORTH HEATING LTD 20.10.00

ITEMS NOT COVERED BY WARRANTY

DOOR GLASS

LABOUR COSTS.

TRAVELING COSTS.

CONSEQUENTIAL LOSS.

CONSEQUENTIAL DAMAGE.

TYPICAL OIL SUPPLY LAYOUT

DIRECTIONAL ANTI
DOWNDRAFT COWL
4" = 77-02-593
5" = 77-02-495
6" = 77-02-451

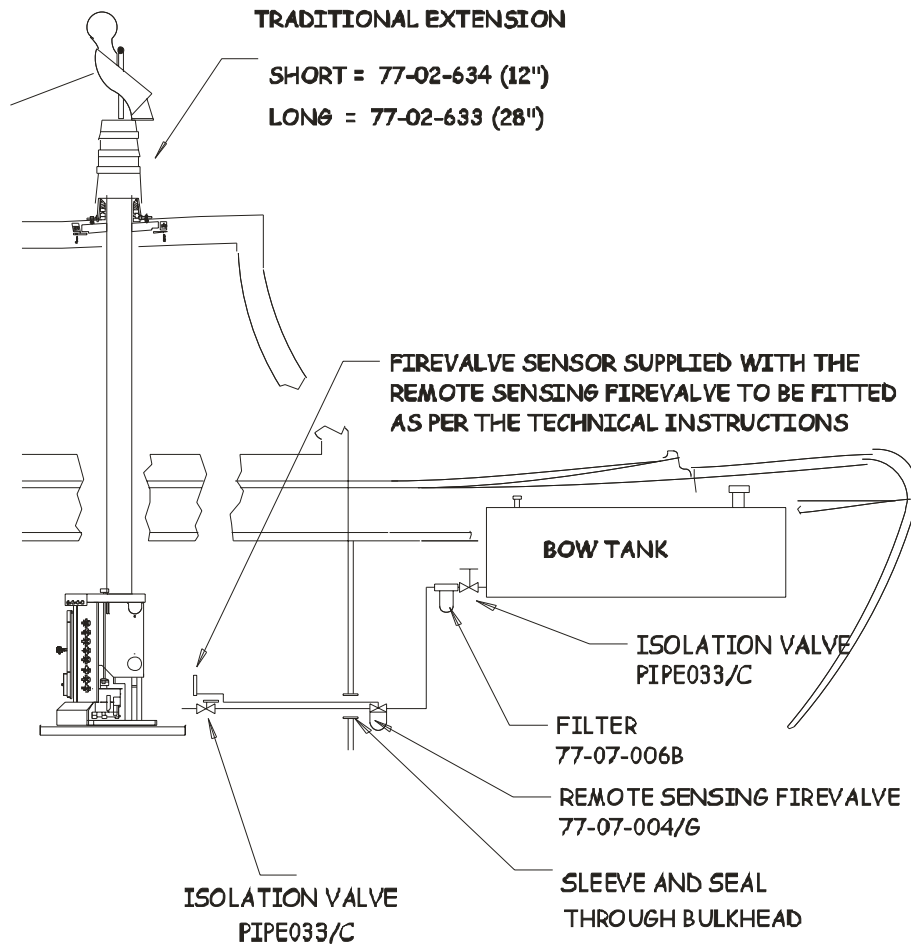

COPYRIGHT HARWORTH HEATING LTD 080800

SCHEMATIC GRAVITY SYSTEM ISS1 OF 08-07-01

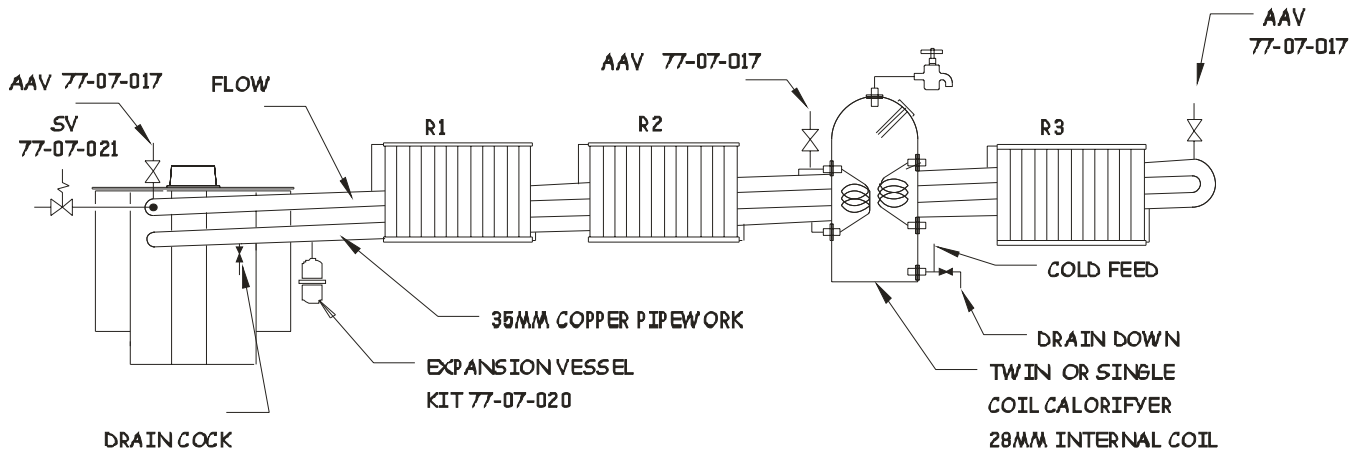

SCHEMATIC PUMPED SYSTEM ISS1 OF 08-07-01

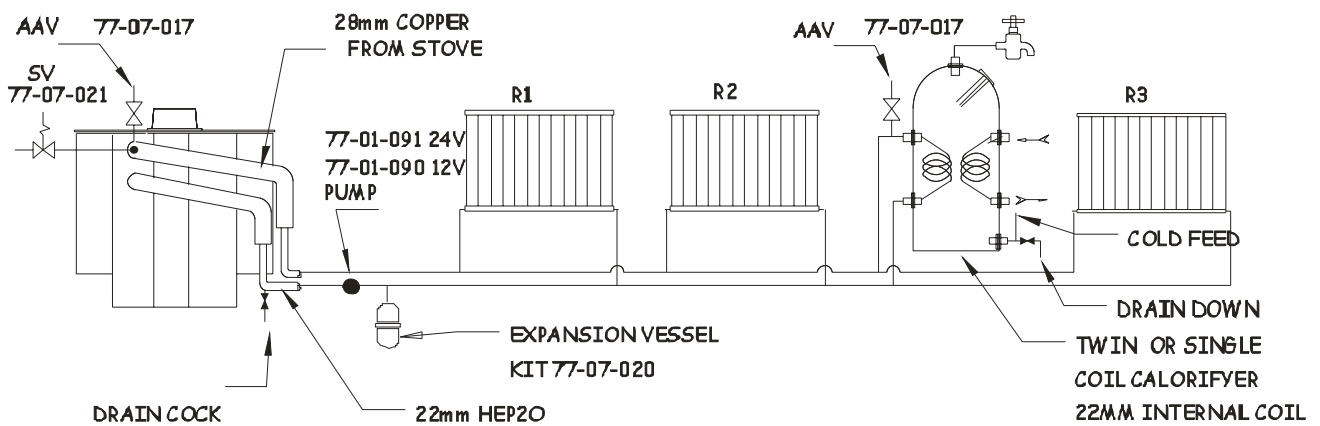

PARTS LIST

DESCRIPTION	QTY PER STOVE	PART NO
SPECIFIC PARTS DRY STOVE		
DRY STOVE FIREBRICK KIT COMPRISING OF :-	1	87-01-450-B
DRY STOVE SIDE BRICKS	2	87-04-501-B1
DRY STOVE BACK BRICK	1	87-04-501-B1-2
BAFFLE PLATE ASSEMBLY (means including fastener)	1	
DRY STOVE OIL VALVE ASSEMBLY	1	78-01-008DRY
REAR HEAT SHIELD FOR B1 DRY		87-01-501-8
SPECIFIC PARTS SMALL BOILER STOVE		
SMALL BOILER ASSEMBLY	1	92-20-102A
SMALL BOILER BACK NUTS	2	
SMALL BOILER STOVE OIL VALVE ASSEMBLY	1	87-01-501VA1

SMALL BOILER STOVE FIREBRICK KIT	1	87-01-501BRICK
REAR HEAT SHIELD FOR SMALL BOIER STOVE		
SPECIFIC PARTS LARGE BOILER STOVE		
LARGE BOILER ASSEMBLY		92-20-105A
TOBY VALVE TO ACCEPT AQUASTAT 35 SEC 4/13	1	78-01-008WET
AQUASTAT ZW12 (3904011)	1	78-01-008C
SLEEVE (FOR AQUASTAT) ZW12 (3904012)	1	78-01-008D
REAR HEAT SHIELD FOR LARGE BOILER STOVE	1	87-01-501-8B
COMMON PARTS FOR ALL STOVES		
COMMON POT ASSEMBLY COMPRISING :-	1	87-01-501A
LIGHTING PORT TUBE PRE FITTED TO THE POT	1	87-01-501-T8
LIGHTING WICK HOLDER (LONG 8KW)	1	87-01-100H2
POT	1	905317-B
LOWER CATALYSER	1	194403-B
UPPER CATALYSER	1	194401-B
RING	1	198205-B
DESCALING DEVICE	1	119216-B
M5 POT NUTS	4	77-02-006-D
CONTROL ROD ASS	1	
FLUE COLLAR (100MM)	1	303829-EF-B
REAR DAMPER (5")	1	78-01-200
OIL FEED PIPE FROM VALVE TO POT	1	77-01-350-C
TIN OF HIGH TEMPERATURE STOVE PAINT BLACK	1	77-01-950
BOLT DOWN BRACKETS	2	87-01-501/25
COMMON DOOR ASSEMBLY COMPRISING :-	1	87-01-450DA
DOOR CASTNG (BLACK)	1	309997-B
DOOR GLASS	1	188798-B
GASKETS FOR GLASS RETAINERS	4	142881-B
GLASS RETAINER SQUARES	4	259015-B
GASKET FOR BRASS KNOB	1	
THERMOCORD SEAL FOR DOOR GLASS	1	181632-B
DOOR ROPE SEAL	1	77-01-918
SCREWS FOR GLASS RETAINERS	4	77-03-017
DOOR ROPE GLUE	1	77-01-965
COMMON FASTENERS AND SPACERS COMPRISING :-		
OIL CONTROL VALVE SPACERS	2	87-01-501CS
OIL CONTROL VALVE SPACER FASTENERS	2	77-02-009-BB
REAR HEATSHIELD SPACERS	4	87-01-501SP1
SPLIT PINS FOR LOWER HEATSHIELD	2	77-02-044
REAR HEATSHIELD SPACER FASTENERS	4	77-02-009-A
HINGE PINS FOR DOOR	2	110404-B
FLUE COLLAR FASTENERS	3	
BOLT DOWN BRACKET FASTENERS	2	87-01-501-25
HEAT SHIELD FASTENERS	2	
M8 DOOR HINGE ASS SET SCREW 50MM	2	77-02-077

DOOR KNOB (BRASS)	1	BRASS026
M8 NUT	2	77-02-072
COMMON OIL FLOW CONTROL ROD ASSEMBLY COMPRISING :-		
SPLIT PIN	1	77-02-044
OIL TRIP ROD (ALLUMINIUM)	1	87-01-501TCR
OIL TRIP SWITCH BLACK KNOB	1	RS686-008
FLOW RATE STICKER	1	PRINT011
COMMON OIL VALVE COMPONENTS COMPRISING :-		
OIL CONTROL VALVE SUPPORT BRACKET		87-01-501-16
OIL CONTROL VALVE INLET FITTING	1	FIT403
OIL CONTROL VALVE OUTLET FITTING	1	FIT404
FASTENERS FOR OIL CONTROL VALVE TO BRACKET	2	77-02-078
COMMON HEAT SHIELD COMPONENTS COMPRISING :-		
LOWER HEAT SHIELD		87-01-501-9
RIGHT SIDE FOR LOWER HEAT SHIELD		87-01-501-10
LEFT SIDE FOR LOWER HEAT SHIELD		87-01-501-10A
OPTIONAL PARTS FOR ALL STOVES		
COAL KIT COMPRISING :-	1	
ONE PIECE SUPPORT FRAME	1	92-20-200-G
CROSS BRACE	1	92-20-200-F
COAL SUPPORT BARS	5	92-20-200-C
FRONT FRET	1	92-20-200-A
COALS MEDIUM	8	COALS-MMC2
COALS SMALL	4	COALS-MMC1
SEA GOING SHIPS VALVE 252AY 4/10 4CST	1	78-01-024
COMMON FIDDLE RAIL KIT COMPRISING :-	1	92-40-070
FRONT BAR	1	87-01-660
SIDE BARS	2	87-01-662
CORNER FINNIALS	4	87-01-655
CENTER FINNIAL	1	87-01-655
M5 FASTENERS FOR FINNIALS	5	77-02-006-CC

© HARWORTH HEATING LTD 30.6.98

This publication may not be copied by any means, without written permission from the authors.

This product is subject to continuous development and improvement and it is consequently acknowledged that due to this process there may be some omissions and errors.

This publication is intended only to assist the reader in the use of this product and therefore Harworth Heating Ltd shall not be liable for any loss or damage whatsoever arising from the use of any information, error or omission found in this guide.

Only approved personnel, WHO HAVE BEEN SUITABLY TRAINED, must carry out maintenance on this product.

