

MAX 1

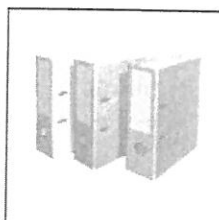

Technical data

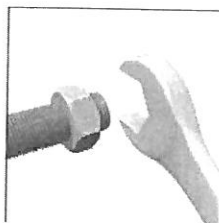

Operating instructions

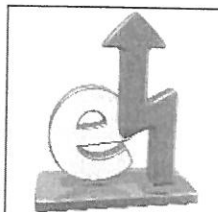

Electric diagrams

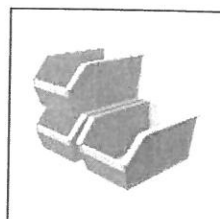

Spare parts list



420010518600

MAX 1 TC B10 230-50-60 TW
MAX 1 TL B10 230-50-60 TW

3142915

Overview - Index of contents

Technical data	EN	3
Working fields	EN	4
Dimensions	EN	5
Operating instructions for authorised specialists	EN	6 - 16
Electric diagrams	EN	17
Spare parts list	EN	18 - 19

Overview / Überblick

Technical data	MAX 1	
Burner output max/min kW - kcal/h	41,4	17,6
	35604	15136
Oil throughput max/min kg/h	3,5	1,5
Hydraulic system 1 stage	1	
Regulating ratio	1:1	
Fuel oil	Light oil (L.C.V. 10.200 kcal/kg max. visc 1,5°E at 20°C) (EL) Hu = 11,86 kWh/kg	
Emission class	Standard Class 2 - OIL EN267 (NOx < 185 mg/kWh)	
Control box	THERMOWATT E-BCU OIL	
Air regulation Air flap	-	
Flame monitor	photoresistor	
Ignition transformer	danfoss / cofi	
Fuel-oil pump	danfoss / suntec	
Electric motor rpm - watt	2800 (3400) rpm	
	75 W	
Voltage	230 V / 50 (60) Hz	
Power consumption (operation)	300 W	
Weight	7 kg	
Protection level	IP40	
Sound pressure level dB(A)	60	
Ambient temp. for storage	-20°...+70° C	
Temperature for use	-10°...+60° C	

Overview - Working fields

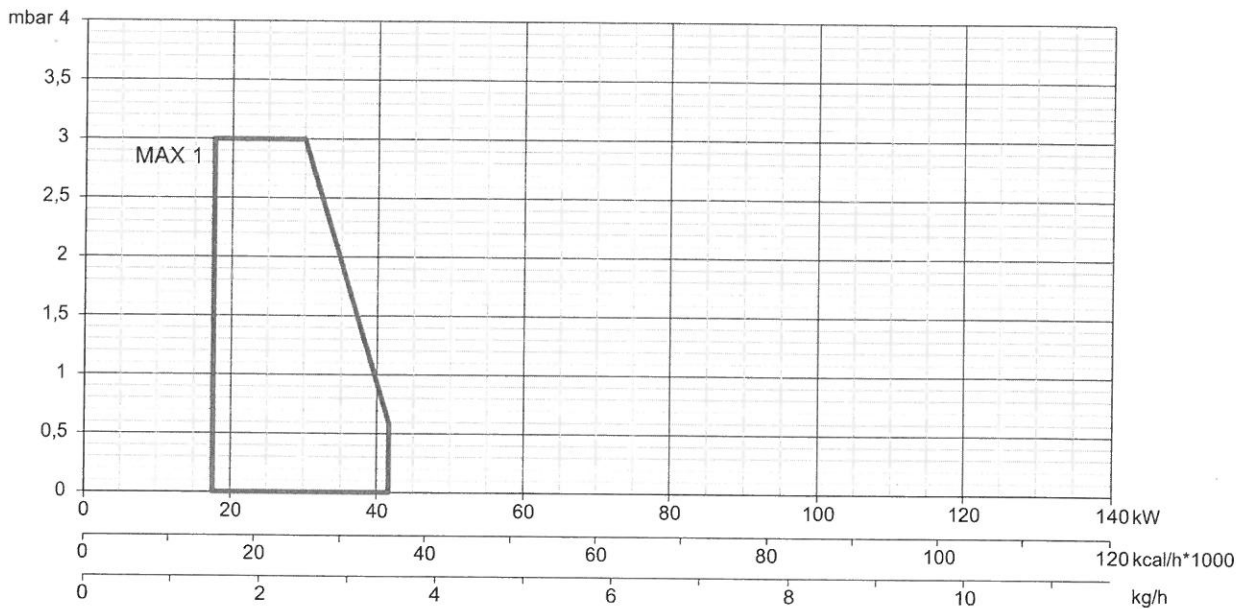
**Working field**

The working field shows burner output as a function of combustion chamber pressure. It corresponds to the maximum values specified by EN 267 measured at the test fire tube.

The efficiency rating of the boiler should be taken into account when selecting a burner.

Calculation of burner output:

$$QF = \frac{QN}{\eta_k}$$

QF = Burner output (kW)

QN = Rated boiler output (kW)

η_k = Boiler efficiency (%)

Overview - Dimensions / Überblick - Größe

MAX 1

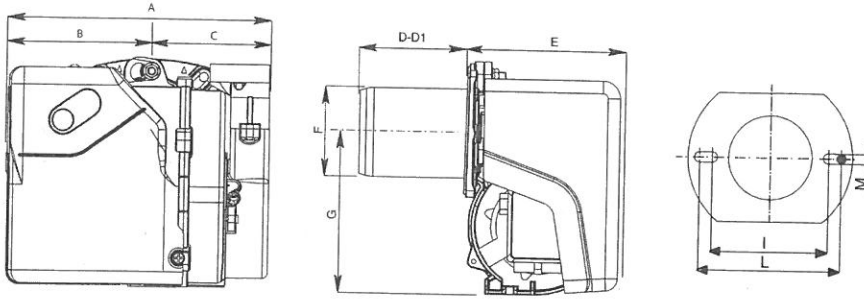

Model	A	B	C	D	D1	E	F	G	I	L	M
MAX 1	263	143	120	80	140	153	89	160	126,5	151,5	M8

Boiler plate drilling

Model	Ø a	Ø b	Ø c
MAX 1	100	126,5	151,5

MAX 1

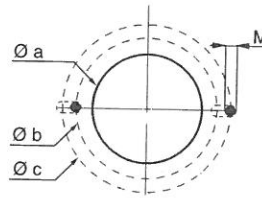

Packaging

Model	X	Y	Z	Kg
MAX 1	310	400	320	7

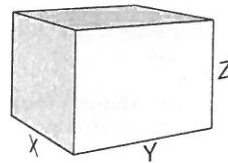

Contents - Index - General warnings - Conformity declaration

Overview	Technical data	3
	Working fields	4
	Dimensions	5
Contents	Index	6
	General warnings	6
	Conformity declaration	6
	Burner description	7
Function	General safety functions	8
	E-BCU OIL control and safety unit	9
	Oil burner pump	10
Installation	Burner assembly	11
	Electrical connection	12
	Checks before commissioning	12
	Oil feeding and suction line	13
Start up	Setting data table - air regulation	13
	Adjusting burner output	14
	Oil pressure regulation	14
Service	Maintenance	15
	Troubleshooting	16
Overview	Electrical diagrams	17
	Spare parts list	18-19

Declaration of conformity for oil burners

We,

Ecoflam Bruciatori S.p.A.

declare under our sole responsibility that the light oil burners named

MAX

conform to the following standards:

EN 267: 2010

EN 60335-1: 2008

EN 60335-2-30: 2006

EN 60335-2-102: 2007

EN 55014-1: 2008 + A1: 2009

EN 55014-2: 1998 + A1: 2001 + A2: 2008

These products bear the CE mark in accordance with the stipulations of the following directives:

2006/95/EEC Low Voltage Directive

2004/108/EEC EMC Directive

2006/42/EC Machinery directive

Resana, 28th June 2011

M. PANIZZON

Important notes

The MAX burners are designed for the combustion of domestic fuel oil EL in accordance with EN267 standards.

Assembly, commissioning and maintenance must be carried out only by authorised specialists and all applicable guidelines and regulations must be observed.

Burner description

The MAX burner is a single-stage, fully-automatic monoblock-type burner. It is suitable for use, within its range of performance, with boilers complying with EN 303 or hot-air generators in line with DIN 4794, DIN 30697 or EN 621. Use for any other application requires the approval of Ecoflam.

The following standards should be observed in order to ensure safe, environmentally sound and energy-efficient operation:

EN 226

Connection of vaporising oil and forced draught gas burners to the heat generator.

EN 60335-2

Safety of electrical equipment for domestic use.

Installation location

The burner must not be operated in rooms containing aggressive vapours (e.g. spray, perchloroethylene, hydrocarbon tetrachloride, solvent, etc.) or tending to heavy dust formation or high air humidity. Adequate ventilation must be provided at the place of installation of the furnace system to ensure a reliable supply with combustion air. Variations may arise as a result of local regulations.

We can accept no warranty liability whatsoever for loss, damage or injury caused by any of the following:

- Inappropriate use.
- Incorrect assembly or repair by the customer or any third party, including the fitting of non-original parts.

Provision of the system and the operating instructions

The firing system manufacturer must supply the operator of the system with operating and maintenance instructions on or before final delivery. These instructions should be displayed in a prominent location at the point of installation of the heat generator, and should include the address and telephone number of the nearest customer service centre.

Notes for the operator

The system should be inspected by a specialist at least once a year. It is advisable to take out a maintenance contract to guarantee regular servicing.

Ecoflam burners have been designed and built in compliance with all current regulations and directives.

All burners comply to the safety and energy saving operation regulations within the standard of their respective performance range. The quality is guaranteed by a quality and management system certified in accordance with ISO 9001:2008.



Contents - Burner description

MAX 4 LN TC 230-50-60 TW

RANGE NAME BY FUEL TYPE

MAX Light oil

MODEL SIZE (Gas: kW; Oil: kg/h)

MAX 4 4 kg/h

OPERATION TYPE

1 stage
R 1 stage with preheater

EMISSION COMBUSTION TYPE

MAX Low NOx Low NOx Class 3 yellow flame (<120 mg/kWh)
MAX Standard Class 2-OIL EN267 (<185 mg/kWh)

HEAD TYPE

TC Short head
TL Long head

FUEL

Light oil
KER Kerosene
BIODIESEL Biodiesel
B10 10 % Biodiesel
D Heavy oil: max visc. 50° E at 50°C

CONFIGURATION ON REQUEST

HT High temperature version

ELECTRICAL SUPPLY TO THE SYSTEM

230-50-60 230 Volt, 50-60 Hz

CONTROL BOX

TW Thermowatt

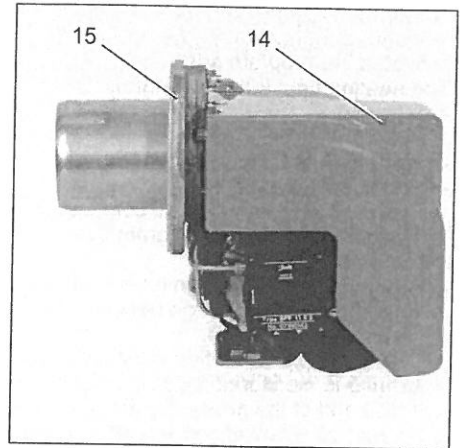

- A1 E-BCU OIL control box
- M1 Electric motor for pump and blower wheel
- T1 Ignition transformer
- Y Graduated rod
- Y1 Solenoid valve
- 3 Air regulation in the burner head
- 5 Fastening screws for equipment plate
- 9 Wieland socket
- 15 Burner flange
- 16 Release knob
- 102 Fuel-oil pump
- 103B Air regulation
- 113 Air intake

Scope of delivery

CB: COMPLETE BURNER

- 1 bag including :
 - multilanguage technical manual.
 - filter and hoses.
 - wieland plug.
 - nozzle and spanner.
 - screws, nuts and washer.



KIT & ACS delivered separately

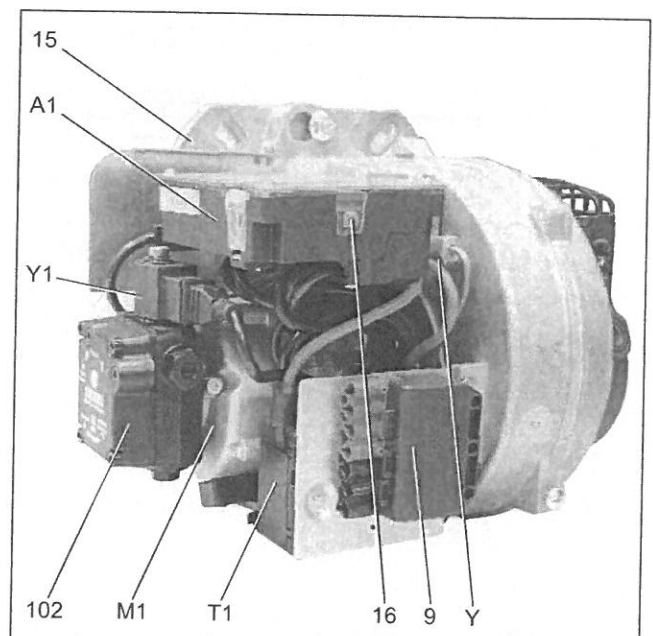
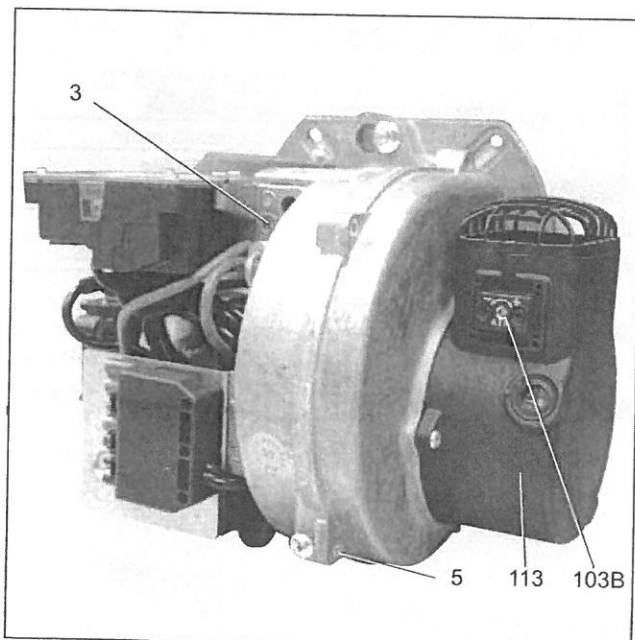
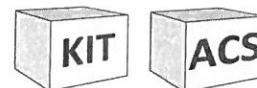

Function - General safety functions

Light oil pre-heating (version R)

If the system demands heat, the pre-heater is switched on first. When the oil preheating temperature is reached, a thermostat in the pre-heater activates the program sequence. The heating time with cold start is approximately 1 minutes.

Operating function

- If heat is requested by the boiler regulator, the automatic oil combustion control unit starts the program sequence.
- The motor starts, the igniter is switched on and the preventilation period of 15 seconds commences.
- During the preventilation period, the furnace is monitored for flame signals.
- At the end of the preventilation period, the fuel-oil solenoid valve opens and the burner starts.
- The igniter remains switched off while the burner is in operation.

Controlled shutdown

- Boiler thermostat interrupts heat request.
- The fuel-oil solenoid valve closes and the flame is extinguished.
- Burner motor switches off.
- Burner enters standby.

Safety function

A safety shutdown occurs:

- if a flame signal is present during preventilation (parasitic flame monitoring).
- if no flame is produced within 5 seconds (safety time) of start-up (fuel authorisation).
- if no flame is produced after an unsuccessful restart attempt in the event of flame failure during operation.

A safety shutdown is indicated by the malfunction lamp lighting up and it is then only possible to reenale the burner by pressing the reset button after the cause of the malfunction has been rectified.

For further information, see the automatic combustion control unit description.

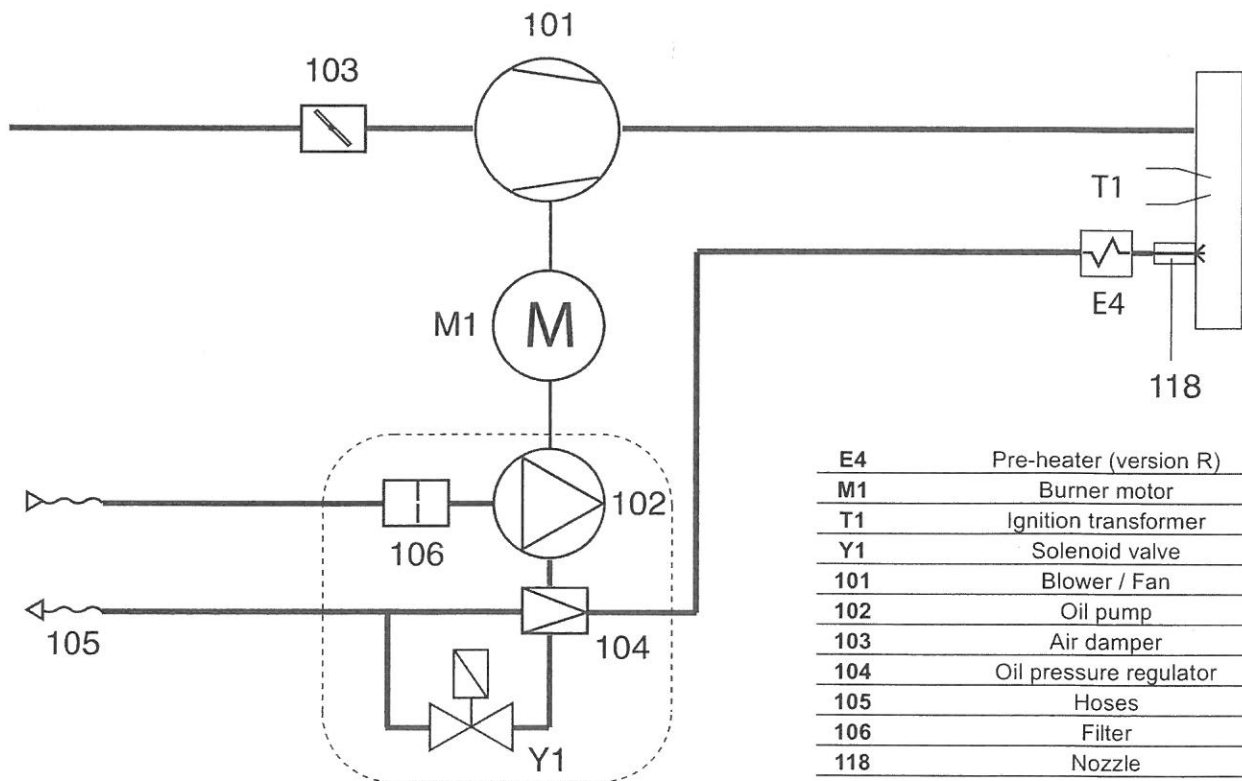

Function - E-BCU OIL control and safety unit

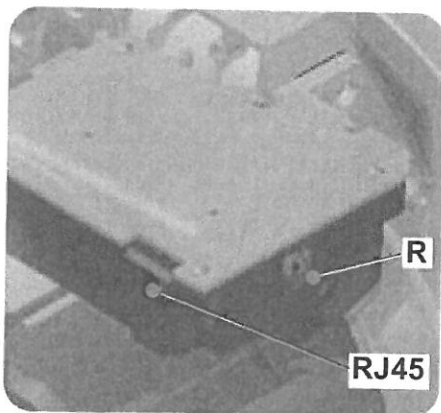

The E-BCU OIL fuel oil control and safety unit controls and monitors the forced draught burner. The microprocessor-controlled program sequence ensures maximum stability of time periods, regardless of fluctuations in the power supply or ambient temperature. The design of the automatic combustion control unit protects it from the effects of brownouts. Whenever the supply voltage drops below its rated minimum level (170 V), the control unit shuts down - even in the absence of a malfunction signal. The control unit switches itself back on again once the voltage has exceeded the 178 V.

Locking and unlocking the system

The control unit can be locked (switched to malfunction) and unlocked (malfunction cleared) by pressing the R reset button, provided the system is connected to the mains power supply.

R - Reset button + lock-out led.

RJ45 - Connector for PC interface (diagnostic, separate item).

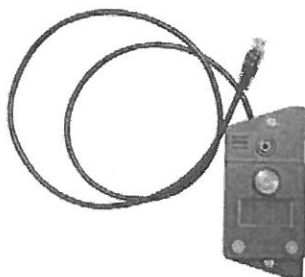

KIT E-BCU
DIAGNOSTIC TOOL
(not supplied)

! Always disconnect the power supply before installing or removing the control unit. Do not attempt to open or carry out repairs on the control unit.

Symbol	Designation
	Waiting for heat request
	Waits for pre-heater (for burner with pre-heater)
	Burner motor on
	Start of ignition
	Flame present

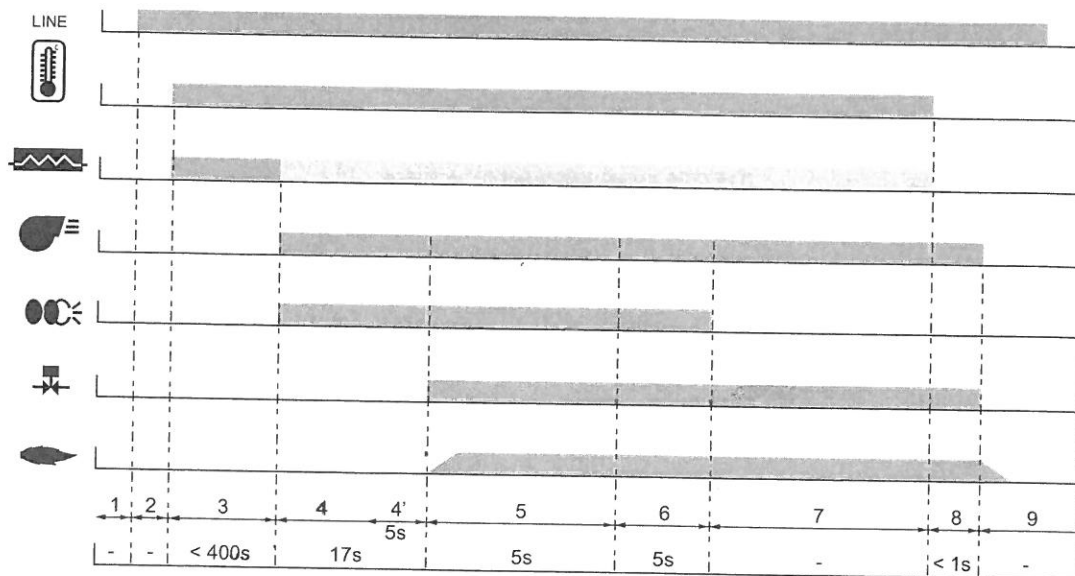

Function - Oil burner pump

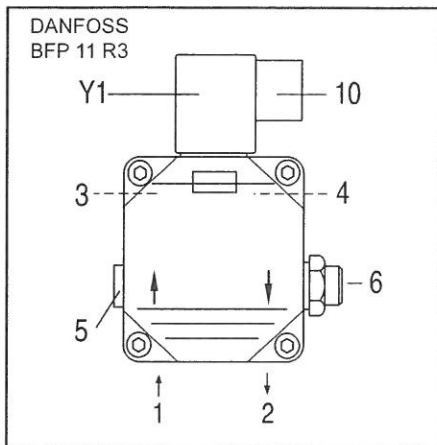

- 1 suction intake connection.
- 2 return connection.
- 3 pressure connection.
- 4 oil pressure gauge connection.
- 5 negative pressure gauge connection.
- 6 oil pressure regulator.
- 10 Solenoid valve electrical connection.
- Y1 fuel-oil solenoid valve.

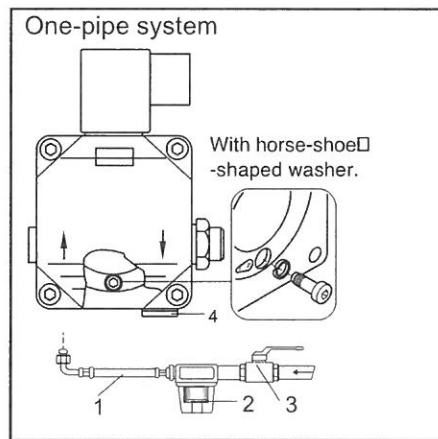
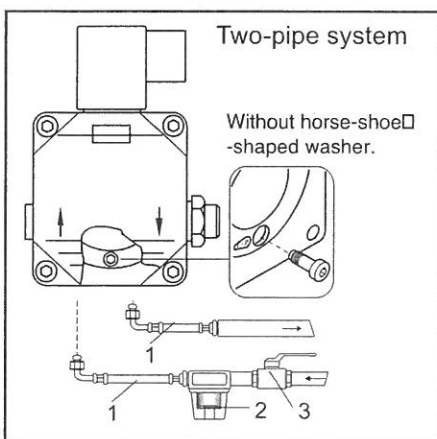

The oil burner pump used is a self-priming gear pump, which must be connected as two-line pump via a bleed filter. There is an intake filter and an oil pressure regulator integrated in the pump. Pressure gauges for pressure measurements and negative pressure measurements must be connected before the equipment is commissioned.

NB: before starting the burner, check that the return pipe is open. An eventual obstruction could damage the pump sealing device.

- 1 Hoses
- 2 Filter
- 3 Oil cock
- 4 Plug

ONE PIPE SYSTEM: If the oil supply circuit is one-pipe system, the pump needs to be modified following instructions in the picture.

Installation - Burner assembly

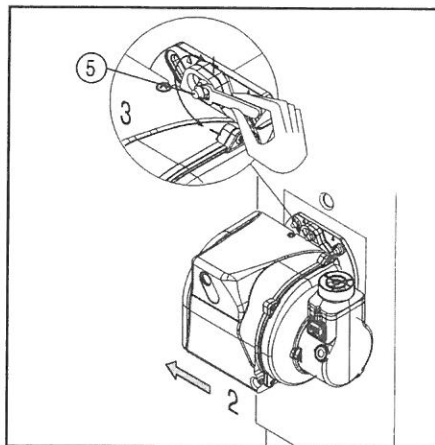
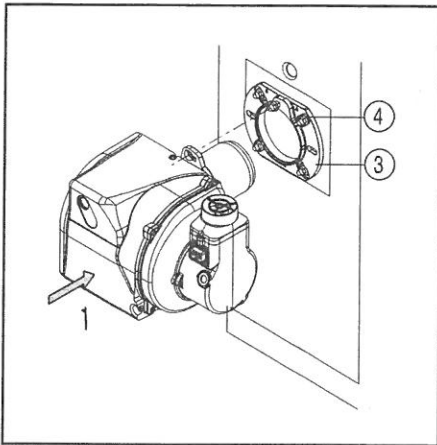

Burner assembly

The burner is fixed by mean of connecting flange and therefore to the boiler.

Installation:

- To fix the flange 3 to the boiler with the screws 4.
- Turn the burner slightly, guide it into the flange and secure using screw 5.

Removal:

- Loosen screw 5.
- Turn the burner out and pull it out of the flange.

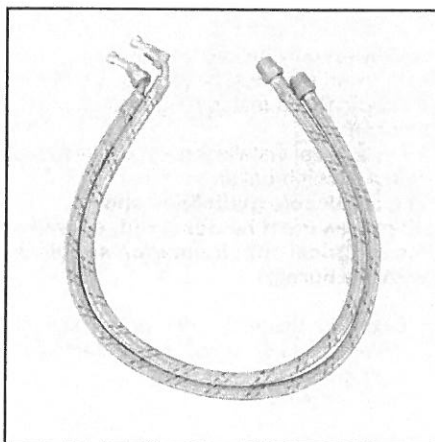

Oil connection

The filter must be located in such a way that the correct hose routing cannot be impaired. The hoses must not kink.

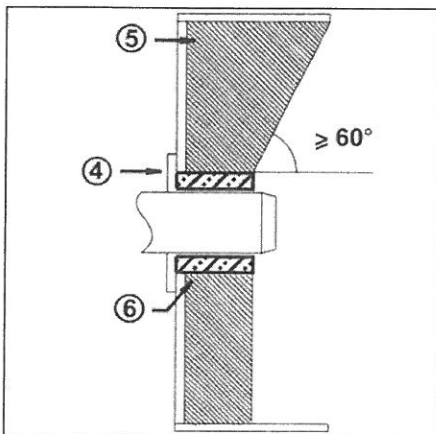

Burner pipe insertion depth and brickwork

Unless otherwise specified by the boiler manufacturer, heat generators without a cooled front wall require brickwork or insulation 5 as shown in the illustration. The brickwork must not protrude beyond the leading edge of the flame tube, and should have a maximum conical angle of 60°. Gap 6 must be filled with an elastic, non-combustible insulation material. For boilers with reverse firing, the minimum burner tube insertion depth A as specified in the boiler manufacturer's instructions must be observed.

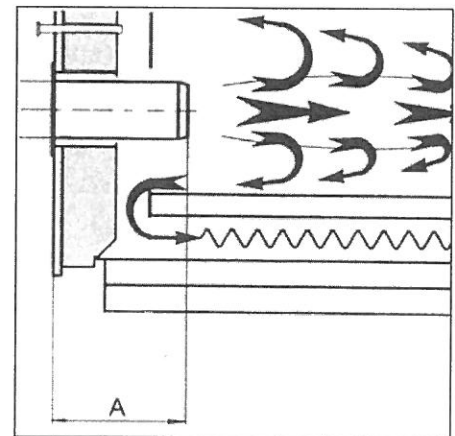

Exhaust system

To avoid unfavourable noise emissions, right-angled connectors should not be used on the flue gas side of the boiler.

Installation - Electrical connection - Checks before commissioning

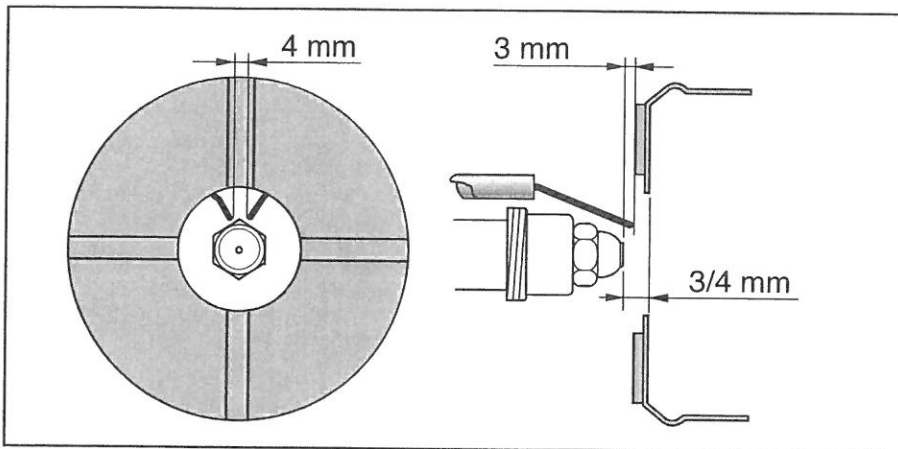

Position of electrodes

Note: Always check the position of electrodes after having replaced the nozzle (see illustration). A wrong position could cause ignition troubles.

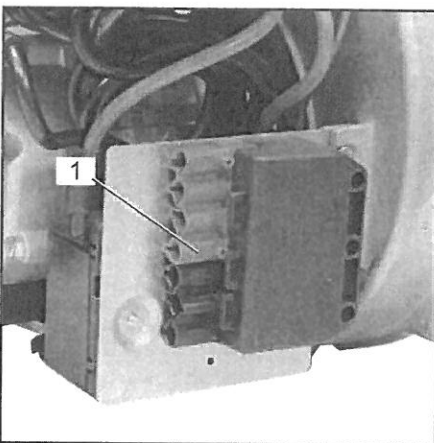

Electrical connection

The electrical installation and connection work must only be carried out by an authorised electrical specialist. All applicable rules and regulations must be observed.

The electrical installation should include a type A circuit breaker.

The applicable guidelines and directives must be observed, as well as the electrical circuit diagram supplied with the burner!

- Check to ensure that the power supply voltage is as specified in the electric diagram and in data plate.
- Burner fuse: 5 A.

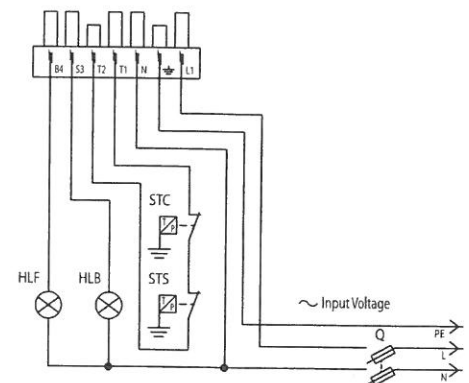

Electrical connection (plug-in)

It must be possible to disconnect the burner from the mains using an omnipolar shutdown device complying with the standards in force. The burner and heat generator (boiler) are connected by a 7-pin connector (fig.1).

Checks before commissioning

The following must be checked before initial commissioning:

- That the burner is assembled in accordance with the instructions given here.
- That the burner is pre-set in accordance with the values in the adjustment table.
- Setting the combustion components.
- The heat generator must be ready for operation, and the operating regulations for the heat generator must be observed.
- All electrical connections must be correct.
- The heat generator and heating system

must be filled with water and the circulating pumps must be in operation.

- The thermostats, pressure regulator, low water detectors and any other safety or limiting devices that might be fitted must be connected and operational.
- The exhaust gas duct must be unobstructed and the secondary air system, if available, must be operational.
- An adequate supply of fresh air must be guaranteed.
- The heat request must be available.
- Fuel tanks must be full.
- The fuel supply lines must be

assembled correctly, checked for leaks and bled.

- A standard-compliant measuring point must be available, the exhaust gas duct up to the measuring point must be free of leaks to prevent anomalies in the measurement results.

Installation - Oil feeding and suction line

Two-pipe siphon feed system

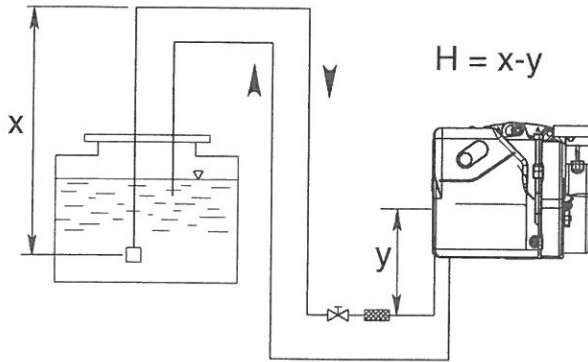

FEEDING LINE WITH DANFOSS BFP11 R3

H (m)	Length pipe (m)		
	ø 6 mm	ø 8 mm	ø 10 mm
0,5	19	60	100
1	21	66	100
1,5	23	72	100
2	25	79	100
2,5	27	85	100
3	29	91	100
3,5	31	98	100

Two-pipe lift system

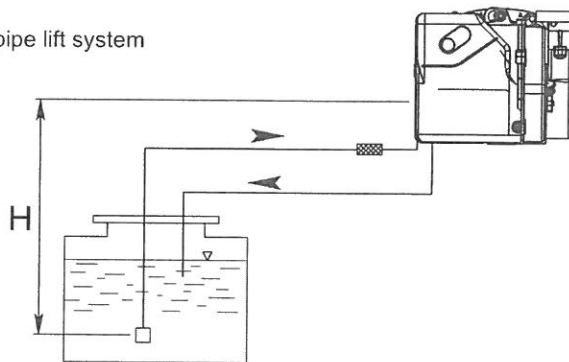

H (m)	Length pipe (m)		
	ø 6 mm	ø 8 mm	ø 10 mm
0,5	15	47	100
1	13	41	99
1,5	11	34	84
2	9	28	68
2,5	7	22	53
3	5	15	37
3,5	-	9	22

Start up - Setting data table - Air regulation

MAX 1	NOZZLE		PUMP	OUTPUT	FIRING HEAD SETTING	AIR DAMPER SETTING	AIR SELECTOR
	gph	spry	bar	kg/h	Pos.	Pos.	Pos.
	0,55	80°S	10		1	3	-

The settings above are **basic settings**. These adjustment values are normally suitable for commissioning the burner. These values have been determined in our test labs and are useful for the first

switch-on as final setting must be done using a combustion analyzer. Favourable combustion values can be achieved using the following nozzles:

DANFOSS H÷S 80°±60°
DELAVAN W 60°
STEINEN S 60°

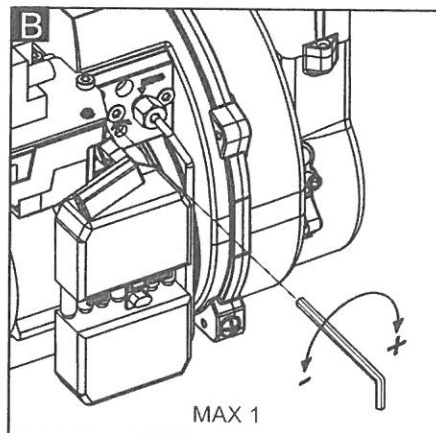
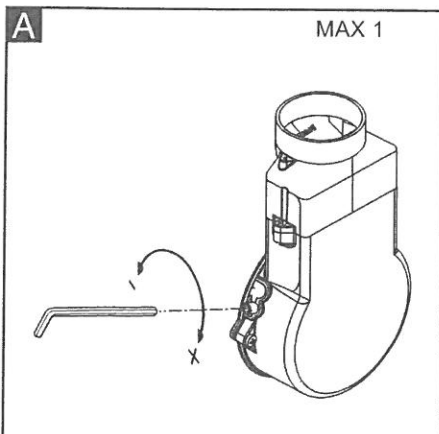

Air damper setting (A).

- To act on the screw in figure:
- to increase output, turn screwdriver clockwise
 - to reduce output, turn screwdriver counterclockwise

Firing head setting (B).

- To act on the screw in figure:
- turn Allen key till you reach the requested value (index 0-4,5).

Start up - Adjusting burner output - Oil pressure regulation



Risk of air blast!

Continuously check CO, CO₂ and soot emissions when adjusting the output of the burner. Optimise combustion values in the event of CO formation. CO must not exceed 50 ppm.

Burner start

Before starting the burner, draw oil in until the filter is completely filled. Then start the burner by switching on the boiler regulator. Open the bleed screw on the oil filter to allow the oil line to bleed fully during the prevention phase. The negative pressure must not fall below 0.4 bar. Close the bleed screw when the filter is completely filled with oil and oil is flowing out without bubbles.

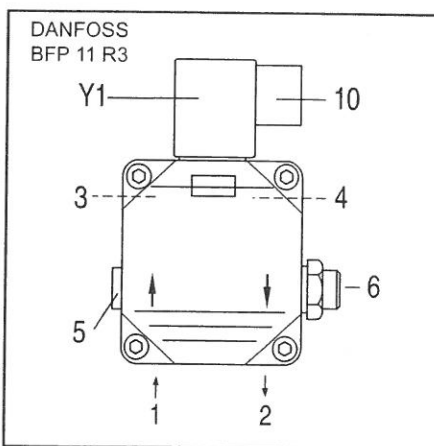

- 1 suction intake connection.
- 2 return connection.
- 3 pressure connection.
- 4 oil pressure gauge connection.
- 5 negative pressure gauge connection.
- 6 oil pressure regulator.
- 10 Solenoid valve electrical connection.
- Y1 fuel-oil solenoid valve.

Optimising combustion values

If the combustion values are not satisfactory modify the position of the combustion head. By doing this the burner ignition conditions and the combustion values change. Compensate for the change in airflow if necessary by adjusting the air flap position.

Note: observe the minimum required flue gas temperature specified by the boiler manufacturer and the requirements demanded of flue gas ducts for avoiding condensation.

Oil pressure regulation

The oil pressure, and therefore burner output, is adjusted using oil pressure regulator 6 in the pump.

Turn to

- right: to increase pressure
- left: to reduce pressure

Connect a pressure gauge at point 4 (with R1/8" thread).

Checking negative pressure

The vacuum meter for checking negative pressure must be connected to point 5, R1/8". Maximum permissible negative pressure is 0.4 bar. At higher negative pressures, the fuel oil gasifies, which causes scraping noises in the pump and ultimately leads to pump damage.

Cleaning the pump filter

The filter is located under the pump cover (SUNTEC) or in appropriate cartridge (DANFOSS). To be able to clean the filter, it is necessary to loosen the screws and remove the cover first (SUNTEC) or to unscrew the screw (DANFOSS).

- Check the pump cover seal and replace the gasket if necessary.

Operating check

Flame monitoring must be checked for safety as part of initial commissioning and also after servicing or if the system has been out of operation for any significant period of time.

- Starting attempt with flame monitor unlit: the automatic combustion control unit must switch to malfunction at the end of the safety time

- Start with flame monitor lit: the automatic combustion control unit must switch to malfunction after 10 seconds of prevention
- Normal start-up: flame monitor goes out when burner in operation; the automatic combustion control unit must switch to malfunction after the restart and end of the safety time

Service - Maintenance

Burner and boiler servicing must only be carried out by qualified personell. The system operator is advised to take out a service contract to guarantee regular servicing.

Attention

- Disconnect the electrical supply before carrying out any maintenance or cleaning work.
- The blast tube and firing head may be hot.

Checking the exhaust gas temperature

- Check the flue gas temperature at regular intervals.
- Clean the boiler if the flue gas temperature is more than 30°C above the value measured at the time of commissioning.
- To simplify the check, use a flue gas temperature indicator.

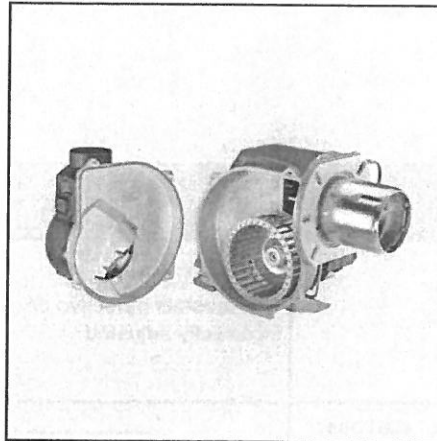
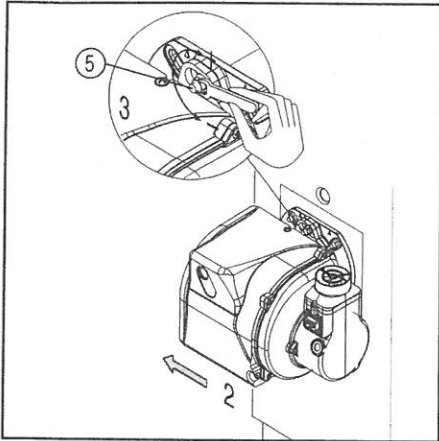

Maintenance on the burner

Maintenance position 1

- Clean fan and housing and check for damage.

Maintenance position 2

- Check and clean the combustion head.
- Replace oil nozzle.
- Check ignition electrodes, readjust or replace as necessary.
- Fit combustion head. Observe adjustment dimensions.
- Fit burner.
- Start burner, check flue gas data, correct burner settings if necessary.

Maintenance position 3

- Check oil supply components (tubes, pumps, oil feed tube) and their connections for leaks or signs of wear, replace if necessary.
- Check electrical connections and connection cables for damage, replace if necessary.
- Check pump filter and clean if necessary.

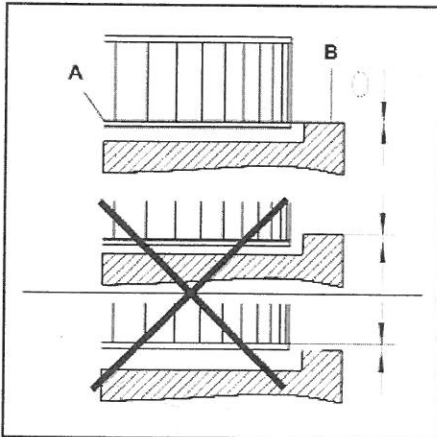

Fan assembly

Observe the positioning diagram below when replacing the motor and blower wheel. The inside flange **A** of the blower wheel must be fitted at the same level as the equipment plate **B**. Insert a straight edge between the wing of the blower wheel and set **A** and **B** to the same height, tighten the set screw on the blower wheel (maintenance position 1).

Nozzle and cleaning replacement

Use only the suitable box wrench provided for this operation to remove the nozzle, taking care to not damage the electrodes. Fit the new nozzle by the same care. Note: Always check the position of electrodes after having replaced the nozzle (see illustration). A wrong position could cause ignition troubles.

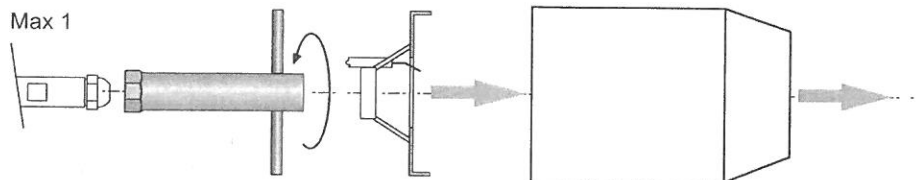

Service - Troubleshooting

Fault diagnosis and repair

In the event of a malfunction, first check that the prerequisites for correct operation are fulfilled:

1. is the system connected to the power supply?
2. is there oil in the tank?
3. are all shut-off valves open?
4. are all control and safety devices, such as the boiler thermostat, low-water detector, limit switch, etc. adjusted correctly?

If the malfunction persists, use the following table.

It is not permitted to repair any components relevant to safety. These

components must be replaced by parts with the same order number.





Only use original spare parts.

NB: after each operation:

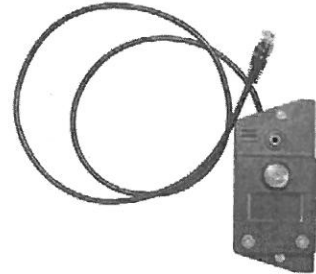
- under normal operating conditions (doors closed, hood fitted, etc.), check combustion and check the individual lines for leaks.
- Record the results in the relevant documents.

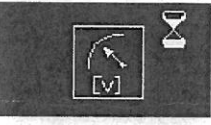
E-BCU display interface must be used to read the faults by service personell.

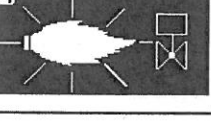
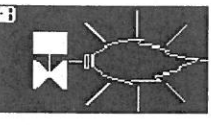

Symbol fault	Fault	Cause	Remedy
	No heat request	Thermostats defective or incorrectly adjusted	Adjust the thermostats, replace if necessary.
	Burner does not start after thermostat shutdown. No malfunction indicated on the automatic combustion control unit.	Drop in supply voltage or power failure. Control unit malfunction	Check the cause of the fall in voltage or the power failure. Replace the control unit.
	Burner starts at switch-on for very short period and then shuts down and the red LED lights up	The control unit has been intentionally locked	Reset control unit.
	Burner starts and then shuts down after pre-ventilation	Flaring during pre-ventilation or pre-ignition	Check ignition sparks/adjust or replace electrode Check/replace fuel-oil solenoid valve
	Burner starts and then shuts down after the solenoid valves have opened	No flame signal at end of safety time	Check the oil level in the tank. Top tank up as required. Open the valves. Check the oil pressure and the operation of the pump, coupling, filter, solenoid valve. Check ignition circuit, electrode adjustment. Clean/replace electrodes. Clean/replace flame monitor.
	Flame extinguishing during operation	Flame goes out during operating phase	Replace the following items as required: Ignition electrodes/ignition cables/ignition transformer/nozzle/pump/solenoid valve/automatic combustion control unit.

Overview - Electric diagrams

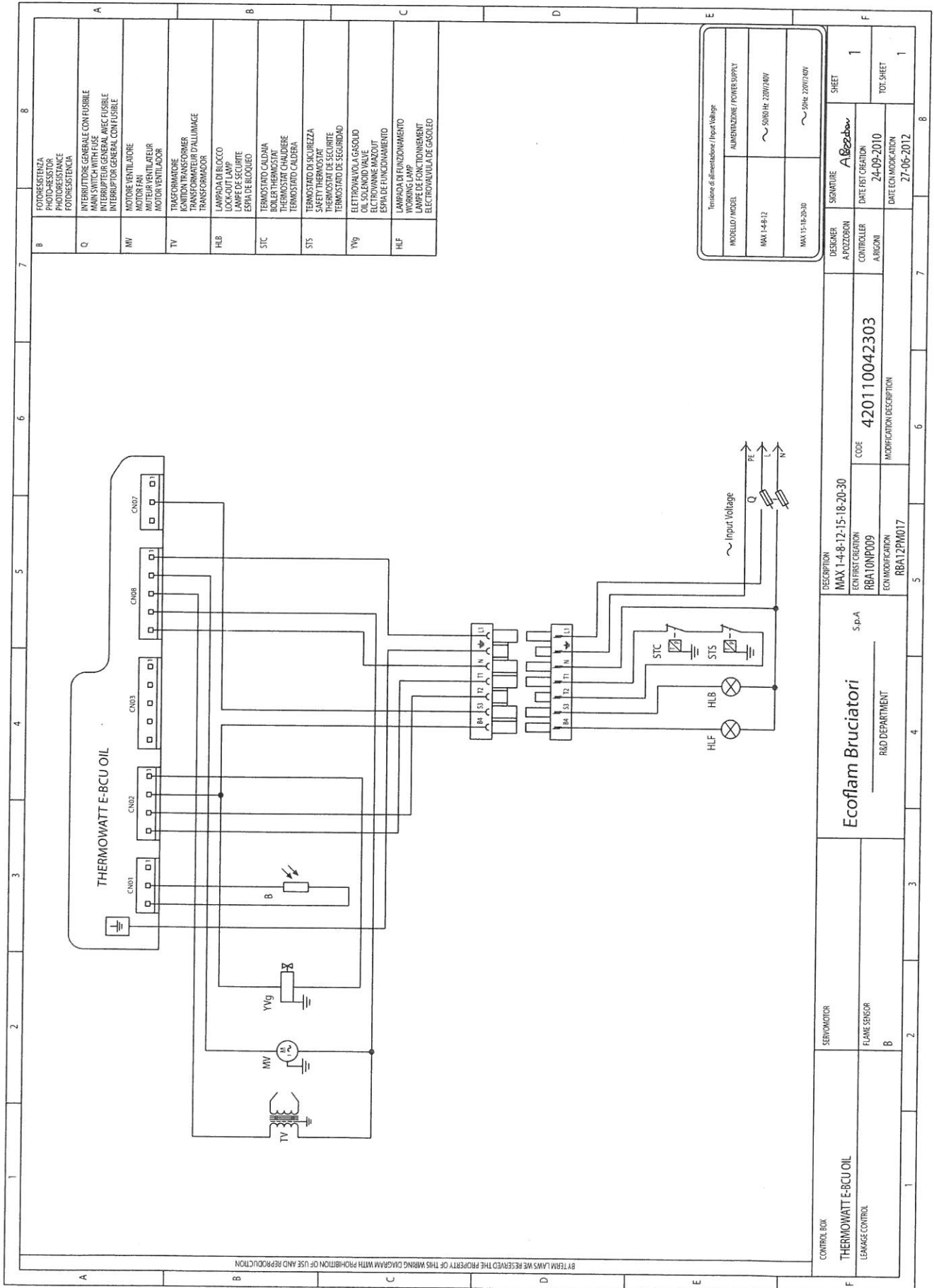

Letter	Symbol	Description
A		FOTORESISTENZA PHOTORESISTOR RESISTOR A LUCE FOTORESISTENCIA
B	Q	INTERRUTTORE GENERALE CON FUSIBILE MAIN SWITCH WITH FUSE INTERRUPTOR GENERAL CON FUSIBLE INTERRUPTOR GENERAL CONTUSIBLE
	MV	MOTORE VENTILATORE MOTOR FAN MOTOR VENTILADOR
	TV	TRASFORMATORE IGNITION TRANSFORMER TRANSFORMADOR D'ALLUMIAGE TRANSFORMADOR
	HLB	LAMPADA DI BLOCCO LOCK-OUT LAMP LAMPARA DE BLOQUE ESPAJA DE BLOQUEO
	STC	TERMOSTATO CALDAIA BOILER THERMOSTAT TERMOSTATO CALDERA TERMOSTATO CALDERA
	STS	TERMOSTATO DI SICUREZZA SAFETY THERMOSTAT TERMOSTATO DE SEGURIDADE TERMOSTATO DE SEGURIDAD
	Vg	ELETTROVALVOLA GAS/OLIO OIL SOLENOID VALVE ELECTROVAVANAS GAS/OLIO ELECTROVAVANAS
	HLF	LAMPADA DI FUNZIONAMENTO WORKING LAMP LAMPPE DE FONCTIONNEMENT ELECTROVALVOLA DE GAS/OLIO

Tensione di alimentazione / Input Voltage	
MODELLO / MODEL	ALIMENTAZIONE / POWER SUPPLY
MAX 1-4-B-12	~ 50/60 Hz 220V/240V
MAX 15-18-20-30	~ 50Hz 220V/240V

DESIGNER	SIGNATURE	SHEET
A POZZOBON	A. Pozzobon	1
CONTROLLER	DATE/FIRST CREATION	TOT. SHEET
A. BIGNONI	24-09-2010	1
	DATE/ENMODIFICATION	
	27-06-2012	

DESCRIPTION		CODE	MODIFICATION DESCRIPTION
MAX 1-4-B-12-15-18-20-30		420110042303	
ECONOMIST CREATION			
RBA10ANP009			
ECONOMIST MODIFICATION			
RBA12PM017			
Ecoflam Bruciatori			
S.p.A			
R&D DEPARTMENT			
CONTROL BOX	SERVO MOTOR		
THERMOWATT E-BCU OIL	FLAME SENSOR		
LEAKAGE CONTROL	B		

Overview - Spare parts list

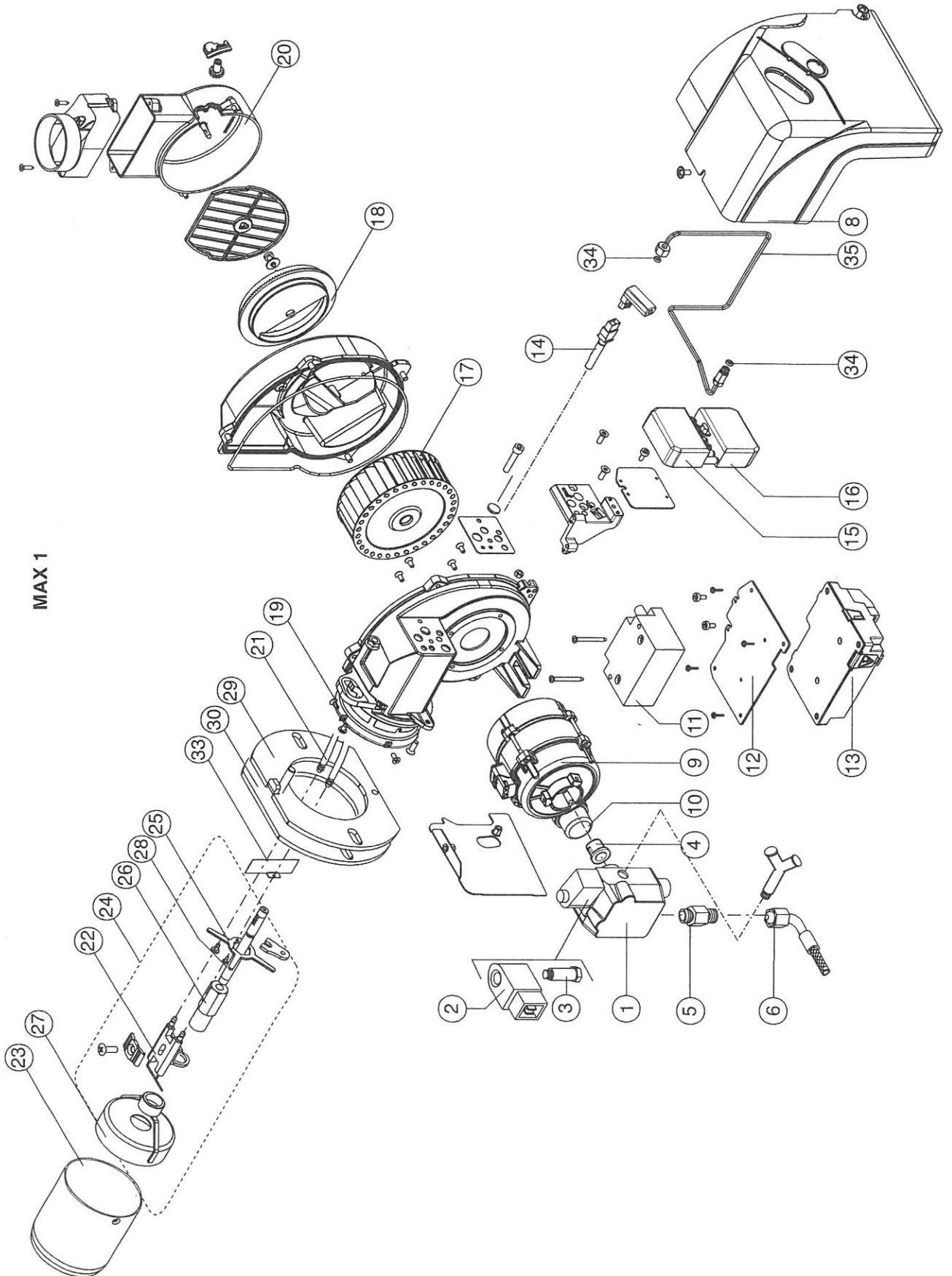

Overview - Spare parts list

n°	Description	MAX 1 code
1	OIL PUMP DANFOSS BFP11 R3 071NO143	65322967
2	COIL DANFOSS	65323773
3	OIL VALVE DANFOSS	65323751
4	COUPLING	65322920
5	NIPPLE	65321179
6	HOSES NW 4X700	65323198
7	FILTER	-
8	COVER	65325528
9	MOTOR 75 W AEG	65322868
10	CAPACITOR 3 µF AEG	65321857
	5 µF SIMEL	65325038
11	IGNITION TRANSFORMER	65323257
12	SUPPORT	65325251
13	CONTROL BOX WITH CABLES THERMOWATT E-BCU OIL	65325255
14	PHOTORESISTOR SATRONIC	65320083
15	SOCKET WIELAND	65322070
16	PLUG WIELAND	65322069
17	FAN 120 x 42	65323826
18	AIR DAMPER	65320519
19	ORING	65321066
20	COVER AIR INLET	65320132
21	CABLES TC	65325252
	TL	65325253
22	ELECTRODES	65320924
23	BLAST TUBE TC	65320333
	TL	65320339
24	FIRING HEAD TC	65325400
	TL	65325401
25	NOZZLE HOLDER SUPPORT TC	65320695
	TL	65320699
26	NOZZLE HOLDER TC	65320708
	TL	65320710
27	DIFFUSER	65320760
28	ROD TC	65324056
	TL	65320204
29	FLANGE	65325174
30	GASKET	65321071
31	AIR SELECTOR	-
32	REAR DISC	-
33	FAN SCOOP TC	65320505
	TL	65320506
34	PIPE GASKET	65321065
35	PIPE	65321508

TC = Short Head TL = Long Head
R= Version pre-heater

Ecoflam

Ecoflam Bruciatori S.p.A.

Via Roma, 64 - 31023 Resana (TV) - Italy

Tel. +39 0423 719500

Fax +39 0423 719580

<http://www.ecoflam-burners.com>

e-mail: export@ecoflam-burners.com

Società soggetta alla direzione e al coordinamento di Ariston Thermo S.p.A.

Via A. Merloni, 45 - 60044 Fabriano (AN) - CF 01026940427

Ecoflam Bruciatori S.p.A. reserves the right to make any adjustments, without prior notice, which is considered necessary or useful to its products, without affecting their main features

Ecoflam Bruciatori S.p.A. si riserva il diritto di apportare ai prodotti le modifiche che riterrà necessarie o utili, senza pregiudicarne le caratteristiche principali.

La maison Ecoflam Bruciatori S.p.A. se réserve le droit d'apporter les modifications qu'elle jugera nécessaires ou utiles à ses produits sans pour autant nuire à leurs caractéristiques principales

Ecoflam Bruciatori S.p.A. se reserva el derecho a introducir en sus productos todas las modificaciones que considere necesarias o utiles, sin perjudicar sus características

"Ecoflam Bruciatori S.p.A." оставляет за собой право вносить в конструкцию оборудования любые необходимые изменения без особого предупреждения.

Ecoflam Bruciatori S.p.A. behält sich das Recht vor, ohne Beeinträchtigung der wesentlichen Eigenschaften für notwendig oder sinnvoll erachtete Änderungen an den Produkten vorzunehmen.