

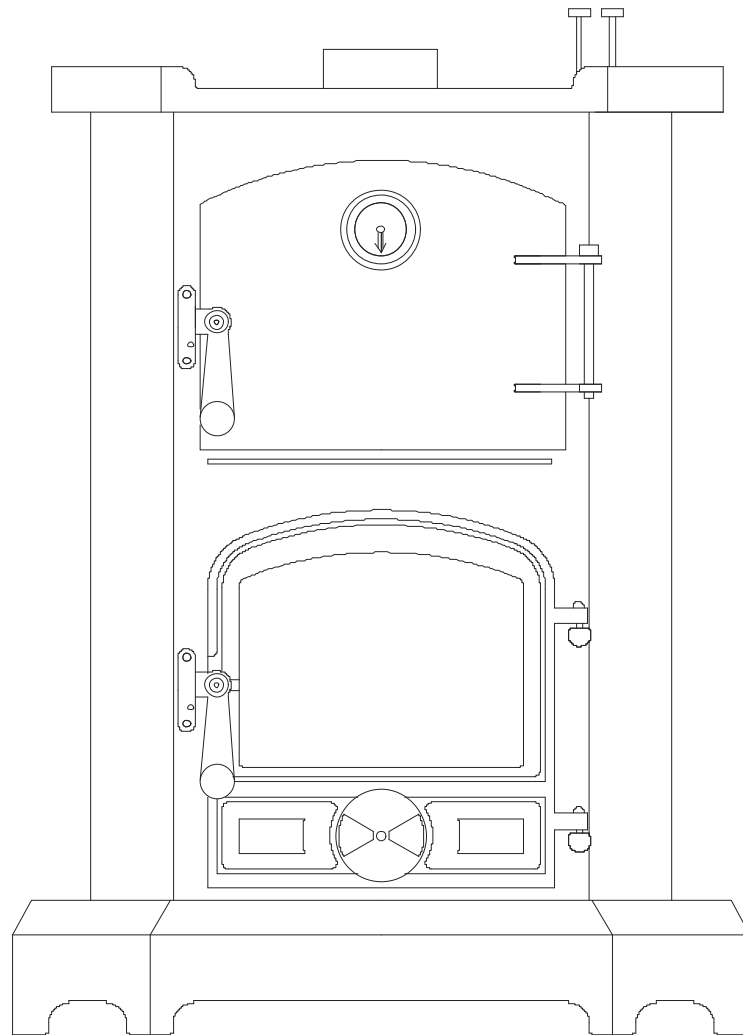

CORNER OVEN OIL APPLIANCE

INSTALLER INSTRUCTIONS ISSUE 1 - 05-02-17



www.harworthheating.co.uk

INDEX

1. BEFORE STARTING THE JOB.	5
ABOUT THE APPLIANCE.....	5
CONTROLS.....	6
2. SAFETY	6
FUMES.....	6
FIRE.....	6
BURNS.....	7
CLEARANCES FROM COMBUSTIBLES (APPLIANCE).....	7
CLEARANCES FROM COMBUSTIBLES (FLUE).....	7
VENTILATION.....	7
IMPACT RESISTANCE.....	7
3. CHIMNEY	7
THE HEIGHT.....	7
THE DIAMETER.....	7
THE TEMPERATURE OF THE GASSES IN IT.....	7
THE RESISTANCE OF THE INNER SURFACE OF.....	7
THE FLUE PIPE OR PIPES.....	7
THE CHIMNEY RULES.....	7
4. FUEL SUPPLY. SEE FIG 4	8
WAXING.....	8
TRIM.....	8
TANK. SEE FIG 4.....	8
OIL LINE. SEE FIG 4.....	8
WATER CONTAMINATION.....	8
REMOTE SENSING FIREVALVE. FIG 4.....	8
ISOLATION VALVES. FIG 4.....	8
SLEEVING. FIG 4.....	9
5. FIREPLACE	9
THE HEARTH.....	9
FIREPROOFING.....	9
APPLIANCE FEATURES.....	9
FASTENING DOWN.....	9
6. FITTING DRY APPLIANCES	9
SELECT LOCATION.....	9
FIT OIL TANK. FIG 4.....	9
RUN OIL LINE. FIG 4.....	9
TRIAL FIREPLACE ASSEMBLY.....	9
TRY APPLIANCE IN POSTION.....	9
ESTABLISH FLUE POSITION.....	9
MARK AND CUT ROOF PLATE.....	9
FIT DECK FLANGE.....	9
FIT FIRESTOP SPACER.....	9
FIT CEILING PLATE.....	9
TRIAL FIT FIRE.....	9
TRIAL FIT EVERYTHING ELSE.....	9
IF IT ALL FITS REFIT IT PERMANENTLY.....	9
SELECT LOCATION.....	9
FIT OIL TANK. FIG 4.....	9

RUN OIL LINE. FIG 4	9
TRIAL FIREPLACE ASSEMBLY.....	9
TRY APPLIANCE IN POSITION.....	9
ESTABLISH FLUE POSITION.....	9
MARK OUT AND CUT THE ROOF PLATE.....	10
FIT DECK FLANGE.....	10
FIT FIRESTOP SPACER.....	10
FIT CEILING PLATE.....	10
ABOVE DECK EXTENSION.....	10
6. FITTING WET APPLIANCES.....	10
EASY ACCESS TO THE BOILER UNIONS.....	10
EASY ACCESS TO THE DRAIN DOWN VALVE.....	10
EASY ACCESS TO THE OIL CONNECTION.....	10
EASY ACCESS TO THE ISOLATION VALVE.....	10
CALORIFIERS. FIG 5	11
VENTING OF AIR. FIG 5	11
PUMPED SYSTEMS. FIG 5	11
SAFETY VALVE. FIG 5	11
WATER TREATMENT.....	11
DRAIN DOWN. FIG 5.....	11
CIRCULATING PUMP. FIG 5.....	11
7. COMMISSIONING.....	11
PRE FIRING CHECKS.....	11
FUEL SUPPLY. FIG 4	11
FUEL.....	11
FILTER. FIG 4.....	11
FIRE VALVE. FIG 4	12
THROUGH BULKHEAD. FIG 4	12
ISOLATION VALVE. FIG4.....	12
PURGING NEW OIL LINES. FIG 4	12
AIR LOCKING. FIG 4	12
ELECTRICAL.....	12
VENTILATION.....	12
HYDRAULIC SYSTEMS. SEE FIG 5.....	12
CHIMNEY SYSTEM.....	12
DISTANCES FROM COMBUSTIBLES.....	12
LIGHTING.....	12
BEFORE ATTEMPTING TO LIGHT THE APPLIANCE.....	12
COMMISSIONING THE HIGH AND LOW FIRE.....	13
CHECKING THE ACTION OF THE BUILT IN THERMOSTAT.....	13
8. FAULT FINDING HEATING SYSTEM.....	13
THE CIRCUIT DESIGN. FIG 5.....	13
AIR LOCKED CIRCULATING PUMP. FIG 5.....	13
AIR LOCKED SYSTEM PIPEWORK. FIG 5.....	14
INADEQUATE SYSTEM PRESSURE HEAD.....	14
INOPERATIVE CIRCULATING PUMP. FIG 5	14
INADEQUATE PIPE SIZEING. FIG 5.....	14
INADEQUATE CALORIFYER DESIGN. FIG 5	14
INADEQUATE APPLIANCE LOCATION.....	14
FLOW OF WATER THROUGH THE BOILER. FIG 5.....	14
WATER THROUGH THE CALORIFYER.....	14

FLOW OF WATER THROUGH THE RADIATORS.....	14
THE SYSTEM IS NOT OVER PUMPING.....	14
LACK OF PRESSURE RELEASE SAFETY VALVES.....	14
FEED AND EXPANSION.....	14
9. FAULT FINDING COMBUSTION.	14
1. RACING.....	14
2. FLUE VACUUM.....	14
3. BURNER RUNS SOOTY.....	14
4. BURNER DOES NOT LIGHT EASILY.....	14
5. OIL WILL NOT ENTER THE POT.....	14
6. OIL SMELLS.....	14
7. DEFLOODING A FLOODED POT.....	14
8. OPERATING OIL FLOW RATES.....	14
10. ROUTINE MAINTENANCE.....	15
1. EVERY 4 WEEKS-:.....	15
2. AS REQUIRED -:.....	15
3. EVERY EIGHT WEEKS -:.....	15
4. EVERY 24 WEEKS-:.....	15
5. ONCE PER YEAR-:.....	15
6. EVERY TWO YEARS -:.....	15
7. AS REQUIRED -:.....	15
11. WARRANTY.....	15
12. WARRANTY ITEMS NOT COVERED.....	16
DOOR GLASS.....	16
LABOUR COSTS.....	16
TRAVELING COSTS.....	16
CONSEQUENTIAL LOSS.....	16
CONSEQUENTIAL DAMAGE.....	16
14. APPLIANCE DISTANCES FROM COMBUSTIBLES.....	16
15. FLUE PIPE DISTANCES FROM COMBUSTIBLES.....	16
16. OIL SUPPLY LAYOUT.....	17
17. PLUMBING LAYOUT OPTIONS.....	18

Read in conjunction with the appropriate:-

1. Oil control valve leaflet.

If you have any difficulties please phone our technical help line on:-

01302 742520 fax 01302 750573

e mail sales@oilappliances.co.uk.

www.oilappliances.co.uk

1. BEFORE STARTING THE JOB.

ABOUT THE APPLIANCE.

The corner oven appliance is a simple development of the corner oil appliance incorporating a small oven built directly on top of a corner oil appliance.

It is installed in the same way as the corner oil.

There are a few changes which are incorporated as follows:-

1. The drip tray has an adjustable plate mounted to it which can be used for levelling purposes.

Drip Tray and Adjuster Plate



Adjuster Plate Locking Fasteners



2. For maintenance purposes the oil control valve has been mounted on a removable plate which allows the valve to be removed from the appliance should the need arise.

To remove the valve, first remove the left and right hand side panels, then remove the oil feed pipe by

disconnecting at the descaling device and then undo the straight compression joint and then remove the oil feed pipe from the valve.

Undo the single locking screw, disconnect the oil flow control rod and the thermostat control rod from the oil control valve and the valve and plate should then slide out.

Removable valve mounting plate.



As per the Corner Oil stove, standard deck flanges and traditional chimney extensions can be used above deck but we do recommend the use of an anti downdraft terminal.

As per the Corner Oil stove the appliance will provide space or combined space and water heating plus cooking on dry models and limited cooking on boiler models.

There are two versions of the appliance, dry and wet. The dry version is designed for space heating and cooking.

The wet version is designed for space and water with limited cooking.

On the wet, boiler version, there are 4 x 1" BSP female sockets for connections to be made to the heating circuits as required at either side of the appliance.

The boiler is high water content and suitable for pumped or gravity systems, pressurised or open vented, provided that they are correctly designed.

OPERATING PRINCIPLES.

The appliance is designed as a continuous running space heater, which burns vaporized diesel fume in a controlled manner utilizing a chimney to discharge the products of combustion and a pumped or gravity fed oil supply.

Once ignition has occurred oil goes into the pot where

it is vaporised and burned at a steady and controlled rate via gravity flow, metered by the OIL CONTROL VALVE.

The oil flow can be controlled from minimum to maximum or any setting in between determined by where you set the oil flow control knob.

Air for combustion

is drawn into the vaporizing pot by the natural action of the negative pressure in the chimney and to allow the chimney to work correctly it is essential that there is adequate, unrestricted ventilation into the area where the appliance is situated and the flue system is warm enough to pull air through the burner in the appliance.

The amount of vapour that can be successfully burned is directly proportional to the amount of air that the chimney can draw into the pot and so to achieve adequate combustion a balanced and appropriate flow of both oil vapour and air is required.

CONTROLS.

The output of the appliance is regulated by the amount of oil for vaporization which is allowed to go into it and this function is controlled by the -:

OIL CONTROL VALVE (O.C.V.), which is situated at the right hand side of the appliance, behind the right hand side panel.

Turning the knob anti clockwise controls the oil flow. The knob is located at the top right hand side of the appliance and is calibrated from off position (fully clockwise) through 6 graduations to maximum.

Controls for the appliance will vary, depending on which valve is fitted to it.

The valve could be an OCI ships valve or a Toby valve and this should be specified with the order for the appliance.

The control for the dry appliance comprises-:

1. Oil flow control only.

The boiler version has extra controls which are-:

1. Oil flow control
2. Thermostat control
3. Safety Stat reset control

The Toby oil control valve only is used on boiler appliances. This valve has a built in, non electric, modulating thermostat control, which will put the fire on to low fire when the target temperature has been achieved.

In addition to this there is also a similar safety stat, which will shut the burner down, should the water exceed 80 deg C.

The safety stat re set control is lifted to reset the

valve, should the stat trip.

The Toby valve has to be tripped into action by lifting the trip button at the left hand side of the control panel.

The flow of oil into the pot can be adjusted via the knob on top of extension rod rising up from the oil control valve.

With the increased flow of oil, extra heat is generated, which in turn stimulates the chimney to work harder and consequently draw more air into the pot to maintain an adequate fuel air ratio.

2. SAFETY.

Take care to make sure that safety and ventilation issues are adequately addressed.

FUMES

When the appliance is first ignited, it may be necessary to warm the chimney and the base of the pot with a propane gun; this will get the cold air moving in the stack and allow the burner to draw in.

Under non starting cold chimney situations, here are the main causes of fume or smoke to leak from the appliance.

- The chimney is blocked.
- There are too many bends in the chimney.
- The above deck chimney extension is not high enough.
- The boat is moored in a position near to high buildings or trees and downdraughting is occurring.
- The chimney is not airtight.

FIRE.

Fire can be caused by a variety of potential danger points and because of the space limitation on boats; this risk is ever present and must be adequately assessed.

The main danger is the effects of heat from the appliance on combustible materials and boat occupants. Make sure that all combustibles are adequately protected from the effects of heat radiation.

The appliance must stand on a fireproof base as per the distance from combustibles table.

On appliances using the coal kit, the floor in front of the appliance must have suitable fire protection extending a minimum of 100mm in front of the appliance.

The appliance has built in rear heat shields and when the appliance is positioned in a suitable location there must be a space of 25mm clearance beyond the outer heat shield, to allow air to rise up and around the heat shields.

The rear of the upper oven is insulated and the insulation is covered by a metal heat shield type plate. **Do not remove the heat shields under any circumstances.**

BURNS.

During normal, day-to-day use, many parts of this appliance, pipe work, and chimney can become too hot to touch.

Where necessary, we recommend that suitable guards be fitted, to provide adequate protection from the heat generated by the appliance. Fireguards must comply with BS6539.

Always use heatproof gloves when working on or near to a hot appliance.

CLEARANCES FROM COMBUSTIBLES (APPLIANCE)

See table in 14.

CLEARANCES FROM COMBUSTIBLES (FLUE)

See table in 14.

VENTILATION.

Ventilation plays a vital role in the fitting and sighting of any appliance.

The provision of ventilation for this appliance is adequately covered by the requirements of the boat safety scheme.

25-cmsq. Minimum permanent ventilation, directly to outside air, must be provided for this appliance.

WARNINGS.

Never try to relight a hot appliance; wait until it has cooled down.

Hot oil vapour is explosive.

Never try to light a flooded pot.

When attempting to light an appliance, make sure that the pot is not flooded with oil by looking into the base of the burner.

If it is flooded remove the excess oil as per instructions in the faultfinding section.

The appliance must be securely fastened down so that it can resist impact or collision and it must be level in both directions.

The appliance must not be operated with the glass front door opened or cracked, or without the lighting port plug fitted.

Only Qualified persons can install unvented plumbing systems.

A suitable and serviceable fire extinguisher should always be readily accessible.

IMPACT RESISTANCE.

The appliance must be securely bolted down so that it can resist impact or collision and it must be level in both directions.

Two fixing brackets are provided; these should be fitted over the oil drip tray up stand and fastened down through the hole provided.

3. CHIMNEY.

The power, (*suck or vacuum the chimney can develop*) depends upon the following:-

THE HEIGHT.

THE DIAMETER.

THE TEMPERATURE OF THE GASSES IN IT.

THE RESISTANCE OF THE INNER SURFACE OF

THE FLUE PIPE OR PIPES.

It is obvious that on a boat all the above elements are in short supply.

Normally, we have low flues which are small in diameter and generally not very well insulated, coupled with all these problems we have an additional one, which is that the boat moves across constantly changing surroundings, through locks, into headwinds and crosswinds, all creating major opportunity for down draughting to occur.

Any bend in any part of the chimney or roughness on the internal chimney wall will slow down the velocity of rising gases and reduce the effectiveness of the chimney.

Any slight reduction in the flue gas temperature will reduce the chimney vacuum or pull, hence when the appliance is slowed down for all night burning, as the flue gas cools down the chimney vacuum reduces and as the chimney vacuum drops, the appliance may well start to burn sooty. This problem is highlighted even more during very cold weather when the chimney can cool down even faster.

THE CHIMNEY RULES.

1. Always use a top outlet for flue pipe take off.
2. Never put any sharp bends in the flue. (*To maintain a concentric fit, we will allow a slight kick off the appliance and a similar kick into the deck flange*).
3. Always try to get the appliance as low as possible in the boat, this will allow installation of maximum length flue pipe.
4. Always have two double walled, above deck extensions, short for cruising and long (28inch minimum) for mooring. Insulated extensions are a thing of the future but it is possible to fill the space using a vermiculite and cement mix sealed off with flexible fire putty or heat proof silicone.

5. Fit a rotary swinging cowl to each extension or make one interchangeable.
6. Clean or have the chimney cleaned regularly. (Frequency depends upon type of fuel and length of time used).
7. Flue pipes should leave the appliance vertically and go through the roof of the vessel vertically.
8. **Under no circumstances should straight flue pipes be wedged in to the stove flue collar at an any angle less than vertical.**

4. FUEL SUPPLY. SEE FIG 4

There are several problems relating to diesel fuel supply, which need be adequately addressed.

WAXING.

Cold weather waxing or thickening alters the flow characteristics of diesel.

An adequate fuel feed supply can turn into an inadequate one when the temperature starts to fall. The worst scenario is fuel feed pipe 50-60 feet long in 8mm dia pipe.

The best-case scenario is a fuel pipe 4 feet long in 10mm dia with insulated lagging.

TRIM.

A minimum pressure head of out 8" is required.

This head is measured from the base of the oil tank to the top of the oil control valve. In some cases this head can be affected by the ballast or trim of the boat.

Take great care to try out all the different ballast and trim possibilities to make sure that adequate oil feed is always available at the outlet end of the fuel pipe before it enters the oil control valve at the appliance.

TANK. SEE FIG 4

If the appliance is fitted at the bow of the boat, a bow tank is recommended.

The tank should comply with the requirements of the boat safety scheme and have:-

- A conveniently sized filler
- A means of venting.
- A conveniently located, easily visible, contents gauge.
- An isolation valve
- An easily replaceable cartridge filter.

Do not use glass filter bowls, they are not acceptable under the boat safety scheme.

Always add a suitable proprietary antifreeze additive

to the appliance fuel for wintertime running.

OIL LINE. SEE FIG 4

The oil feed line starts after the fuel filter and proceeds to the point of entry, which is where the oil line goes into the cab or saloon of the boat.

Where oil lines go through bulkheads, use correct bulkhead fittings.

The diameter of the oil line is dependant upon the length of run.

At this point it is necessary to fit a remote sensing fire valve, designed to shut off the oil supply, should a fire occur near to the appliance.

If the bubble appliance is fitted up to the first bulkhead it will be necessary to fit the isolation valve outside the cabin or saloon of the boat.

WATER CONTAMINATION.

Because of the high risk of fuel contamination with water, we strongly recommend the fitting of a high volume water trap in the oil supply line.

REMOTE SENSING FIREVALVE. FIG 4

The fire valve has a capillary tube on the end of which is a temperature sensitive phial, run the capillary tube with the oil line up to the appliance and carefully fit the sensing phial 15mm pipe clips in front of the drip tray on the fireplace hearth, directly in front of the combustion air restrictor.

Before it is fitted try the fender on the appliance to make sure that the fender does not foul the sensing phial.

The sensing phial may be visible through the bottom of the fender, to mask it, paint it with matt black paint available from our sales desk.

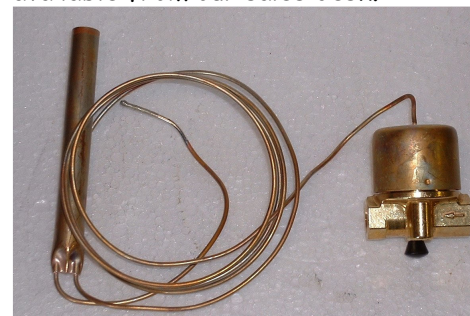

When fitting the fire valve make sure that where the capillary and oil line go through the bulkhead in separate sleeved tubes, so that the capillary can be withdrawn separately should it ever need replacing.

For fitting of long oil feed lines which pass through bulkheads and various other parts of the boat it may well be necessary to fit more than one fire valve, especially where the oil line passes through an area where a fire could occur i.e. kitchen area etc.

ISOLATION VALVES. FIG 4

Two isolation valves are required, one fitted directly into the oil control valve to allow you or the service man to turn the oil off should the need arise, and one on the oil tank fitted before the filter.

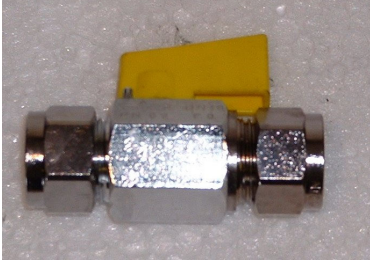

SLEEVING. FIG 4

Where the oil line goes through panels, a suitable sleeve must be fitted and sealed with a suitable sealant.

5. FIREPLACE.

Try to use materials, which are easy to keep clean and fireproof such as tiles, asbestolux, TAC board or vermiculite boarding.

THE HEARTH.

The hearth must be:-

FLAT - SECURE - FIREPROOF AND LEVEL IN BOTH DIRECTIONS.

See (Distance from combustibles.)

FIREPROOFING.

The vertical walls of the fireplace must be fireproofed, suitable materials would be tiles, asbestolux sheet, compressed vermiculite board.

APPLIANCE FEATURES.

The appliance has a base plate, which is designed to do two jobs,

- It acts as a drip tray to catch any oil spill.
- It acts as a spacer to set the appliance at a suitable distance from the vertical walls of the fireplace to allow adequate cooling air to flow around the oil valve.

FASTENING DOWN.

It is important to fix the base tray down to the hearth but don't drill through it as this will allow oil to leak from it should a spill occur. Clips to go over the top of the up stand are provided for this job.

6. FITTING DRY APPLIANCES.

SELECT LOCATION.

FIT OIL TANK. FIG 4

RUN OIL LINE. FIG 4

TRIAL FIREPLACE ASSEMBLY.

TRY APPLIANCE IN POSTION.

ESTABLISH FLUE POSITION.

MARK AND CUT ROOF PLATE.

FIT DECK FLANGE.

FIT FIRESTOP SPACER.

FIT CEILING PLATE.

TRIAL FIT FIRE.

TRIAL FIT EVERYTHING ELSE.

IF IT ALL FITS REFIT IT PERMANENTLY.

SELECT LOCATION.

The appliance can be located in any suitable corner. It and the flue system must be securely fastened, so as to withstand the normal day-to-day situations, which will be encountered in a narrow boat.

These could be:-

- Impact by other vessel.
- Impact into lock gate.
- The pitching and rolling effects of inland water sailing.
- Etc.

There are two angle brackets provided with the appliance, which hook over the front lip of the base tray and are screwed down to the hearth.

The location must have adequate protection from the effects of radiated and conducted heat as specified in section 4 and FIG1.

FIT OIL TANK. Fig 4

The oil tank will be fitted in the bow area and must comply with the requirements of the boat safety scheme. See schematic FIG 4.

RUN OIL LINE. FIG 4

Run the oil line and fit all the required components as described in sec 4 and shown in FIG 4.

TRIAL FIREPLACE ASSEMBLY.

The oil line and the fire valve sensor will have to pass through the fireplace, make sure that you make adequate provision for this and the remote sensing fire valve.

TRY APPLIANCE IN POSTION.

Try the appliance in position and make sure that the oil feed and remote sensing fire valve fit as required.

ESTABLISH FLUE POSITION.

Normally the appliance will be fitted in a corner, in a suitable fireplace; this will predict the angle at which

the flue pipe will have to be fitted.

The flue pipe will normally run at a slight angle to allow it to terminate through the ceiling, in a suitable position.

It is important to make sure that the flue fits concentrically at both the appliance end and as it passes through the fire stop spacer and deck flange. To achieve this the pipe will have to be marked out, notched and re-welded. Make a template to work from. When final fitting of the flue pipe occurs, make sure that the decorative top frame is fitted to the appliance, before the final fixing.

MARK OUT AND CUT THE ROOF PLATE.

FIT DECK FLANGE.

If you are going to use a standard deck flange for 6-inch extensions you will have to cut off the lower extension with a grinder to allow fitting of the fire stop spacer.

The deck flange will be bolted to the roof plate with a seal of silicone rubber applied between the joint.

The flue pipe provided with the appliance will be marked and trimmed off 10mm below the top of the deck flange to allow the flexible fire-cement to be flounced into a suitable taper.

The glass fibre rope will be wrapped around the flue pipe and gently pressed down on to the fire stop spacer, allow 10mm at the top of the joint and pack the gap with the flexible fire cement which will form a seal.

The deck flange will form the base for the traditional chimney extension to be fitted.

FIT FIRESTOP SPACER.

The fire stop space will be fitted in between the deck flange and the ceiling plate concentric to the flue access hole cut in the roof plate of the boat.

It will provide heat protection for any combustible materials located near to the through roof location.

The centre hole is cut deliberately undersize to accommodate differing flue sizes and angles.

It will be necessary to open up the centre hole to fit the flue pipe; this can be done by using the flue pipe as a template and carefully marking round it.

File the excess material away with a rough rasp. (Do this a little at a time to make sure that a good fit is achieved.)

The top surface of the spacer may also need trimming to provide a snug fit up to the inner surface of the roof steelwork.

FIT CEILING PLATE.

The ceiling plate will be fitted inside the boat to finish

off the through roof fitting of the flue pipe.

It will be screwed up to the trimming timber via 4 countersunk wood screws.

ABOVE DECK EXTENSION.

A traditional above deck extension can be fitted in line with normal practice.

We recommend that a short extension is used for cruising and a min 28" extension is used when mooring.

In each case we recommend the use of a rotating cowl to minimise the effects of down draught.

Fit the side panels 1 x left and 1 x right hand sides.

Fit the front fender.

6. FITTING WET APPLIANCES.

Installation of the wet appliance will be the same as the dry except that when dealing with the location an extra element comes in to the equation and that is connecting the appliance up to the heating circuit.

The appliance has a fully integral, powerful boiler, which forms the outer sides of the triangular shape and can be fitted to open vented or pressurised systems.

When connecting appliances to pressurised systems make sure that the Toby oil control valve and matching aqua stat are fitted.

Before designing the fireplace, take great care about making provision for the boiler connections and remember that the whole essence of the Corner Bubble is to make the finished job look like a piece of integrated design.

To facilitate removal of the appliance, make sure that there is

EASY ACCESS TO THE BOILER UNIONS.

EASY ACCESS TO THE DRAIN DOWN VALVE.

EASY ACCESS TO THE OIL CONNECTION.

EASY ACCESS TO THE ISOLATION VALVE.

Water can be connected to the appliance via 4 x 1 inch BSP female sockets, welded into the boiler at the rear top and bottom.

Alternative access to either side of the appliance, allows the installer to fit the appliance in either port or starboard locations.

Make sure that the vertical sides of the fireplace can easily accommodate the pipe work.

When installing water heating Bubble appliances, the space heating output will be reduced.

The boiler is high water content and suitable for pumped or gravity systems both open vented or pressurised.

If you are not suitably qualified, arrange for a heating engineer to do the design and fitting work for you. See FIG 5 for schematic layout.

CALORIFIERS. FIG 5

Indirect calorifiers must be used on gravity or pumped systems.

If you are going to install a gravity system you must make sure that you purchase a special calorifier with a 28 mm internal diameter coil, **don't be put off by suppliers who say that they have 28mm connections which are adequate, they are not as effective.**

On gravity systems the calorifiers must be located higher than the appliance and as close as possible to it, obviously keeping horizontal runs as short as possible.

VENTING OF AIR. FIG 5

Gravity or Pumped systems can be fitted with open vented or pressurised systems.

If open vented systems are used the feed and expansion tank must be as close as possible to the boiler and be fitted at the highest part of the circuit. Consult an experienced boat-heating engineer for advice on feed and expansion tanks.

To vent the system of air use automatic air vents on all possible air lock locations.

PIPE WORK. FIG 5

All gravity pipe work must rise on flow and fall on return and be a minimum of 28mm dia. (35mm dia preferred)

To reduce resistance to flow:-

- Use swept bends, do not use elbows.
- Use copper pipe work.
- Use high water content radiators.

The primary circuit must have a total length of not more than 6 meters otherwise the recovery time of the calorifier will be increased beyond an acceptable period of time.

Primary circuit pipe work must not have valves or other devices that can be used to interfere with the free flow of water.

PUMPED SYSTEMS. FIG 5

Always come off the appliance with 28mm copper for a minimum run of 350 mm before dropping on to 22mm hep 2o

To ensure suitable flow of water through the primaries a suitable injector tee should be used. Great care should be taken with the positioning of the circulating pump and the feed and expansion tank to make sure that the water flows where it should and that over pumping does not occur.

The heating circuit must be piped in 22mm copper or

Hep 2o with 15mm stabs to radiators.

Where additional radiators are fitted as heat leaks, the pipe work must be kept as short as possible, rise on feed and fall on return.

SAFETY VALVE. FIG 5

A 1" safety valve must be fitted as close to the boiler as possible (within 300mm) and the outlet from it must be directed to a safe location so as not to present any danger should the valve blow-off and exit steam or boiling water.

Note, safe location could be through the side of the boat, with a deflector to stop any horizontal emission.

WATER TREATMENT.

To reduce the build up of lime scale in the primary circuit pipe work the temperature of the water should not be allowed to exceed 65 Deg C and a suitable water treatment should be added.

If the boat is to be left unattended the water, in the heating system should also have suitable antifreeze added or be drained down.

DRAIN DOWN. FIG 5

A drain down valve should be fitted at the lowest point of the circuit.

CIRCULATING PUMP. FIG 5

On pumped systems make sure that the circulating pump is fitted in such a way as to make it easily replaceable, this means lock shielded valves at either side and easy access.

7. COMMISSIONING.

If the appliance has been fitted to an existing heating system, make sure that the system is adequately designed and complies with the details specified in this manual.

If the heating circuit does not comply, it must be modified, before attempting to light the appliance.

Commissioning takes the following form:

PRE FIRING CHECKS.

LIGHTING.

POST FIRING CHECKS AND ADJUSTMENTS.

PRE FIRING CHECKS.

FUEL SUPPLY. FIG 4

Tank, check for leaks-stability-height-position-vent. Check for leaks on the entire oil feed line from tank to appliance.

FUEL.

Check for correct grade.

FILTER. FIG 4

Is it fitted-check for function and leaks?
Oil line- check for function, positioning, material suitability and leaks.



FIRE VALVE. FIG 4
Check for function and leaks.

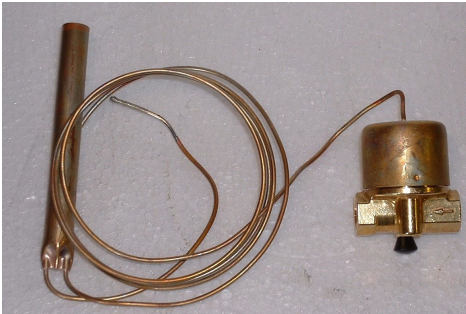

THROUGH BULKHEAD. FIG 4
Bulkhead fittings to be used.

ISOLATION VALVE. FIG4
Check for function, convenience of positioning and leaks.

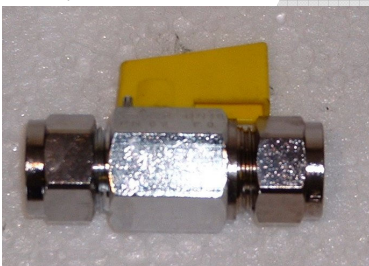

PURGING NEW OIL LINES. FIG 4
Flush at least 5 litres of oil through the line to check for contamination and to clear the oil line of installation debris and trapped air.

AIR LOCKING. FIG 4
Make sure that the oil feed supply pipe is level and has no potential for air locking. (Kinks, wavy runs, and sudden changes in level or slope).

ELECTRICAL.
Check for correct fusing, location and specification of any isolation devices.

VENTILATION.

Make sure that adequate ventilation is provided in line with boat safety scheme.

HYDRAULIC SYSTEMS. SEE FIG 5

Water systems should be pre-checked for leaks and tests must be made to make sure that water will flow freely through the boiler and that the boiler and pump is vented and free from trapped air.

Make sure that the heat leak circuit is adequate and unvalved.

CHIMNEY SYSTEM

Chimney heights must be a minimum of 1.8 meter for low fire use and 2.2 meter for high fire use.

Check the appliance is fitted with adequate clearances from combustibles.

Check that the combustion air restrictor is functioning correctly.

DISTANCES FROM COMBUSTIBLES

Make sure that both the appliance and flue system comply with the required distances from combustibles.

LIGHTING.

WARNING FOR BOILER APPLIANCES.

*If the appliance is fitted with a boiler, air locks or poor water flow through it may cause damage.
Make sure that the boiler has been vented of all air*

BEFORE ATTEMPTING TO LIGHT THE APPLIANCE.

Note; oven stoves are very efficient and as a consequence of this the flue pipe is slow to heat up. Most of the initial heat gets absorbed by the oven therefore before attempting to light the stove especially on a cold boat, it is advisable to pre heat both the burner pot and the flue pipe to make sure that the slug of cold air in the flue and appliance is rising and will allow air for combustion to be pulled into the burner pot. If the flue is not drawing air and the appliance is cold, fumes may well leak from the appliance and the ignition process can be long winded.

Lighting the appliance takes a little time and patience; the following procedure should be adopted.

Open the front door.

Remove the coal kit if it has been supplied with the appliance.

Remove the inner mesh catalyser



Turn the oil on at full rate and allow oil to flow into the bottom of the pot to form a pool about the size of a small digestive biscuit and then turn the oil off.

Do not allow any depth of oil to build up.

Light a small piece of firelighter (about the size of a pineapple chunk) and place it into the centre of the pot.

Replace the lower burning ring, the mesh catalyser and the coal kit and then leave the door slightly open whilst the firelighter gets the oil going.

If fume leaks out of the appliance this is a sign that the flue pipe is not hot enough and needs to be pre heated.

After 30 to 40 seconds, you will notice the flame start to establish itself and spread around the bottom of the pot.

When this occurs, close the door and turn the oil on to its minimum setting.

If the flame goes out or runs very sooty this is a sign that the flue is not hot enough.

After two or three minutes the flame should then slowly change from yellow into blue flame combustion and settle down to a steady burn.

Note there may be the occasional growl or audible vibration whilst the burner settles down into blue flame combustion.

Allow the burner 10 - 15 minutes to stabilise and the increase the flow of oil as required, moving by one increment of the dial only.

Do not leave the appliance unattended during the lighting and stabilising procedure.

COMMISSIONING THE HIGH AND LOW FIRE.

Adjustments should be made by reference to the oil valve booklet supplied with the appliance

Allow at least one hour for the chimney and appliance to warm up thoroughly before making any adjustments to the high or low fire screws.

When the burner has established good blue flame combustion turn it up to half output. (Setting 3 on the fuel flow control knob) and let it stabilize.

Turn the appliance down onto minimum firing rate and

let it stabilize.

After stabilization there should be a dull red glow in the catalyser with wispy blue flames flickering just over the top of it, approximately level with the top of the pot.

If the flame falls into a dirty rolling yellow flame and the catalyser is not dull red then the low fire will need to be increased until the burner can support the required blue flame combustion.

When you are happy with the low fire, set the high fire.

Turn the oil flow knob up to setting 4, let the flame stabilize, and look at it, if it is stable and blue, turn it up slowly using the control knob, letting it stabilize after each movement, *if the flame starts to go yellow with long flame combustion, it is running fuel rich and the high fire screw needs adjusting to reduce the flow of oil. (Screw the adjuster screw in to reduce the high fire oil flow.)*

Before adjusting the high fire screw, turn the flame down and let it stabilize in blue flame combustion, adjust the high fire screw by half a turn in and try turning the fuel flow up, if it is still fuel rich repeat the process until the high fire flame is running blue with flicks of yellow in the tips.

On the Socomef pot, the **high fire flame** will be set approx 40mm higher than the top of the pot.

CHECKING THE ACTION OF THE BUILT IN THERMOSTAT.

Boiler appliances have a thermostat assembly attached to the top of the oil control valve.

After the high and low fire has been set, check the action of the thermostat and overheat stat.

Do this by turning off the circulating pump and putting the appliance on to high fire.

As the boiler temperature increases the thermostat will shut the appliance down on to low fire, because the circulating pump is not working the boiler will carry on increasing temperature, at approx 80 deg C the safety stat will shut the oil valve down and the appliance will go out.

If this does not occur there could be a fault on the thermostat assembly.

8. FAULT FINDING HEATING SYSTEM.

If the system does not perform well check the following-:

THE CIRCUIT DESIGN. FIG 5

AIR LOCKED CIRCULATING PUMP. FIG 5

AIR LOCKED SYSTEM PIPEWORK. FIG 5

INADEQUATE SYSTEM PRESSURE HEAD.

INOPERATIVE CIRCULATING PUMP. FIG 5

INADEQUATE PIPE SIZING. FIG 5

INADEQUATE CALORIFYER DESIGN. FIG 5

INADEQUATE APPLIANCE LOCATION.

The appliance is fitted out of level, allowing an air pocket to build up in the top of the boiler, causing subsequent kettling and damage to thermostat sensing phial

FLOW OF WATER THROUGH THE BOILER. FIG 5

WATER THROUGH THE CALORIFYER.

FLOW OF WATER THROUGH THE RADIATORS.

THE SYSTEM IS NOT OVER PUMPING.

LACK OF PRESSURE RELEASE SAFETY VALVES.

FEED AND EXPANSION.

Is it fitted in the correct place?

9. FAULT FINDING COMBUSTION.

1. RACING.

1. Audible vibrations generated by the flame caused allowing by too much oil in the pot, too quickly.
1-1. Turn off the oil flow until the burner has settled down to a steady burn rate and then turn the fuel on again but don't let the flame go out otherwise the burner **MUST** be allowed to cool down fully before a re ignition is attempted.

2. FLUE VACUUM.

1. The pot type burner is extremely sensitive to flue vacuum variations.
2. Good combustion will not be possible unless our instructions on chimneys and flue vacuum are followed. See fig1
3. If the burner does not burn with a blue flame, recheck the chimney vacuum and oil flow rate.
4. If the burner does not run well check that the seals in the appliance are good and that there is no ingress of air into the appliance flue ways.
5. Check that the correct fuel oil is being used.
6. Check the levels.

3. BURNER RUNS SOOTY.

Comments made on this subject assume that the appliance has been running normally for some time. If the appliance soot's up this indicates that there is not adequate air for blue flame combustion or there is an excess of fuel.

Check that the chimney is working correctly. (This means pulling enough air into the burner to allow correct blue flame combustion to occur.

Check that the fuel is the correct type and quality.

Check that the flow rates are correct.

Where burners are run at high fuel flow rates on low chimney vacuums, long unsatisfactory yellow flame combustion and bad sooting will occur.

To rectify this problem reduce the high fire flow rate screw on the Oil Control Valve until blue flame combustion occurs.

Never switch from low settings to high settings; a longer burner life will be achieved if the regulator is moved only by one number at a time leaving approx. one minute between each setting change.

4. BURNER DOES NOT LIGHT EASILY.

Read the instructions in the lighting section of this publication.

5. OIL WILL NOT ENTER THE POT.

Is there oil in the fuel tank?

Has the fire valve tripped?

Has the isolation valve been accidentally turned off?

Is the oil turned on at the oil flow control knob on the valve?

Is the oil feed pipe from the valve to the pot?

Blocked. (Unlikely)

Has the water stat tripped off on the aqua stat?

Has the aqua-stat been damaged by overheating.

To check this out, remove the aqua-stat from the valve and remove the phial from the boiler, re cock the valve and test fire the appliance. See Fig 4 Toby Valve document.

Note this type of damage is not covered by the warranty.

6. OIL SMELLS.

Visual check on all joints for obvious leaks.

Check that the descaling lever packing gland nut is adjusted.

7. DEFLOODING A FLOODED POT.

To carry out this procedure you will need -:

- a. A small leak proof plastic bag.
- b. A small sponge.
- c. A larger plastic bag for disposal of the residue.
- d. A pair of disposable plastic gloves.

If the pot becomes flooded, de flood it is as follows -:
Put a small plastic bag into the appliance and sponge from the pot into the bag, when the excess oil has been removed put the plastic bag and sponge into another plastic bag and dispose of it.

8. OPERATING OIL FLOW RATES.

OIL Flow rates in cc per minute.

Min	Max
4cc	10cc

Oil Flow Rates In litres per hour.

.24 litres	.6 litres
------------	-----------

Oil Flow Rates In litres per 24 hours.

5.76 litres	14.4 litres
-------------	-------------

Oil Flow Rates In litres per 7 x 24 hours.

40.32 litres	100.8 litres
--------------	--------------

10. ROUTINE MAINTENANCE.

Continuous running assumed.

1. EVERY 4 WEEKS-:

Operate the descaling lever by turning it completely two or three times.

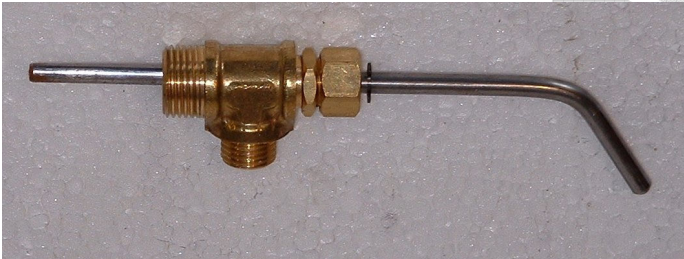

2. AS REQUIRED -:

Clean inside of door glass.

3. EVERY EIGHT WEEKS -:

Clean the burner completely by removing all the inner components as follows,

1. Open the front door.
 2. Remove the coal kit if it has been supplied with the appliance.
 3. Remove the inner mesh catalyser.
 4. Remove the lower burning ring.
- Scrape the bottom of the pot and remove all carbon build up.
Reassemble in the reverse order.

Corner appliance pot.



Section through corner appliance pot minus catalyser.

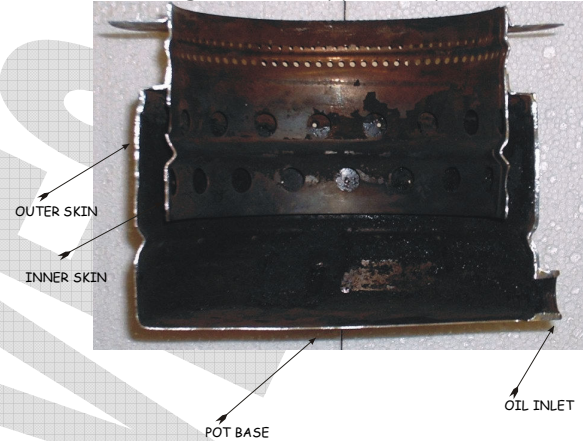

4. EVERY 24 WEEKS-:

4-1. Tighten up the compression nut on the descaling device to stop oil smells.

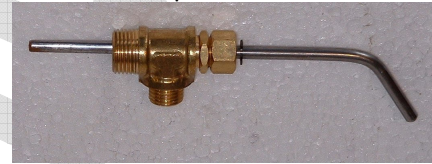

4-2. Section through descaling device.

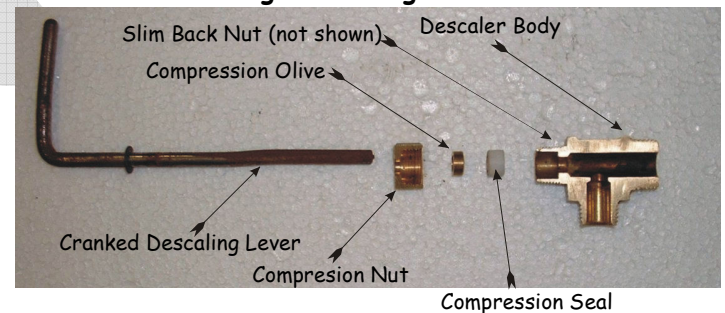

5. ONCE PER YEAR-:

Have your service man replace or clean all the filters in the oil supply line.

6. EVERY TWO YEARS -:

Have your service man clean the filter in the Oil Control Valve and check the function of all the safety equipment associated with the appliance, oil supply and plumbing system.

Remove and clean out the oil supply pipe from the valve to the pot.

7. AS REQUIRED -:

Keep the Coals, Coal kit, and burner inners in good condition, replace as necessary.

11. WARRANTY.

You are advised that if Harworth Heating Ltd is called out to appliances under warranty claims, where no

appliance fault can be found, charges will be made at the rate of £125.00 per hour, including travelling time.

Fill in the warranty form and returned it to us, the information recorded on the warranty form helps us to deal with any problems you may encounter.

Where we do not hold returned warranty forms replacement parts would only be issued when we are sure that the appliance has not been damaged by improper use or installation.

The warranty covers PARTS ONLY for a period of ONE YEAR and is conditional upon all the requirements

of our installation instructions being fully adhered to.

12. WARRANTY ITEMS NOT COVERED.

DOOR GLASS.

LABOUR COSTS.

TRAVELING COSTS.

CONSEQUENTIAL LOSS.

CONSEQUENTIAL DAMAGE.

14. APPLIANCE Distances from Combustibles

Appliance Type	ABOVE	BELOW	SIDES.	BACK	FRONT	HEARTH
BOAT B1	400	25	300	150 FROM HEAT SHIELD	400	25 THICK X 150
BOAT B2	400	25	300	150 FROM HEAT SHIELD	400	25 THICK X 150
BELFORT	400	25	300	150 FROM HEAT SHIELD	400	25 THICK X 150
CORNER	200	25	200	25 FROM HEAT SHIELD	300	25 THICK X 150
CORNER OVEN	150	15	200	25 FROM HEAT SHIELD	300	15THICK

ROUND	200	ALLOW 300 ALL AROUND THE APPLIANCE	25MM THICK HEARTH
-------	-----	------------------------------------	-------------------

Protection can be gained by the use of -:

- Sheet metal heat shields and spacers.
- Heat resistant boards.

Combustible materials can be-:

- Wooden furniture.
- Curtains.
- Wooden panels or frames adjacent to the flue pipe or where it passes through the deck of the boat.
- Carpet or flooring close to the appliance.
- Items near to the appliance, which could fall onto it and ignite, should the boat suffer a slight impact.

15. Flue Pipe Distances from Combustibles

For all appliances-:

150 for single skin pipes.

25 mm for insulated flue pipes.

16. Oil Supply Layout

FIG 4

CORNER STOVE OIL LAYOUT ISS 2

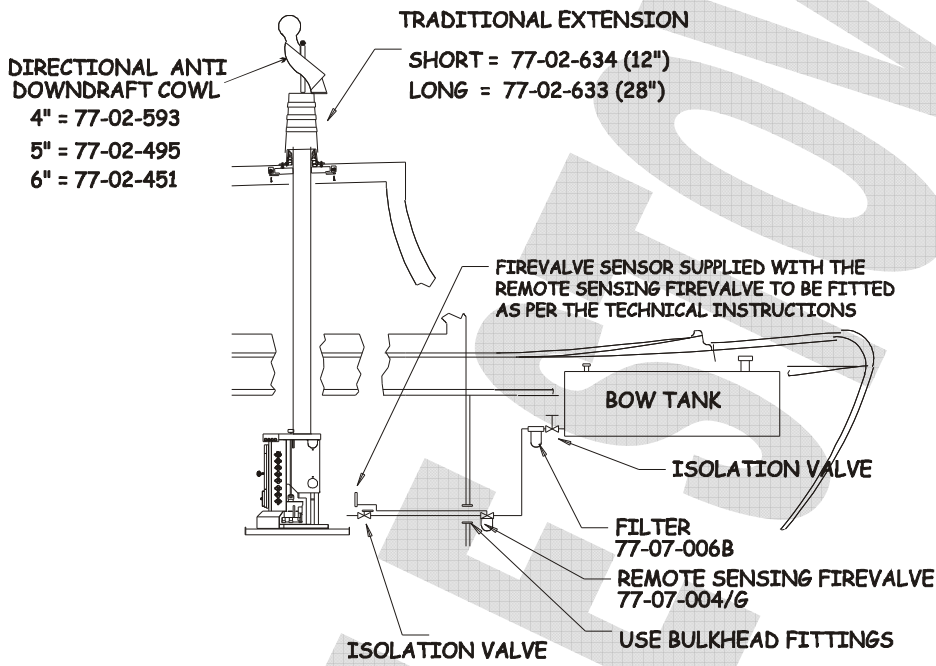

COPYRIGHT HARWORTH HEATING LTD 080800

17. Plumbing Layout Options

Each of the stoves has a different output to water and the installing engineer should first of all establish the boiler output to water and then design the heat losses accordingly.

Note that some of the boilers can only provide heat for a calorifier and towel rail.

FIG5

SCHMATIC GRAVITY SYSTEM ISS1 OF 08-07-01
READ IN CONJUNCTION WITH TECHNICAL INSTALLATION MANUAL

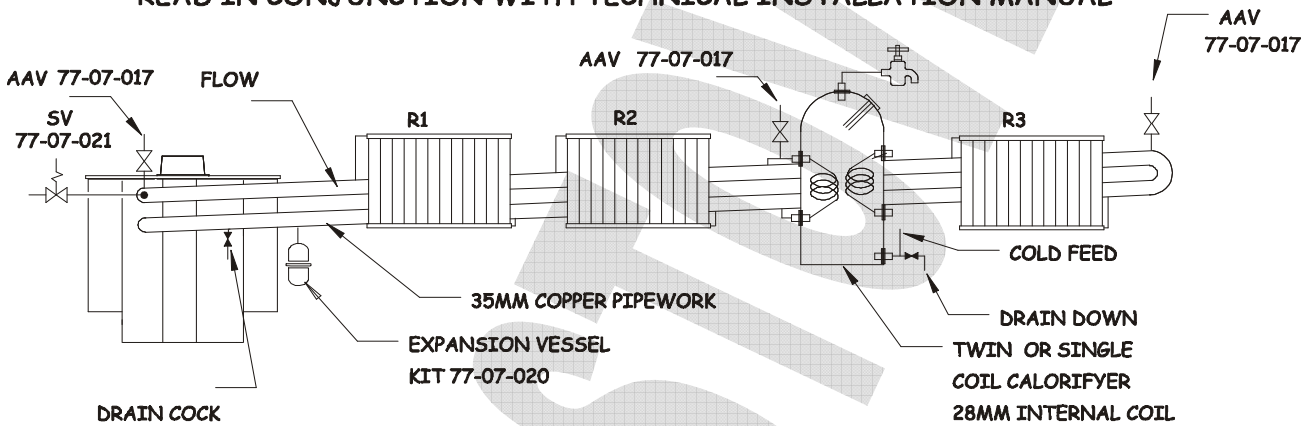

SCHMATIC PUMPED SYSTEM ISS1 OF 08-07-01

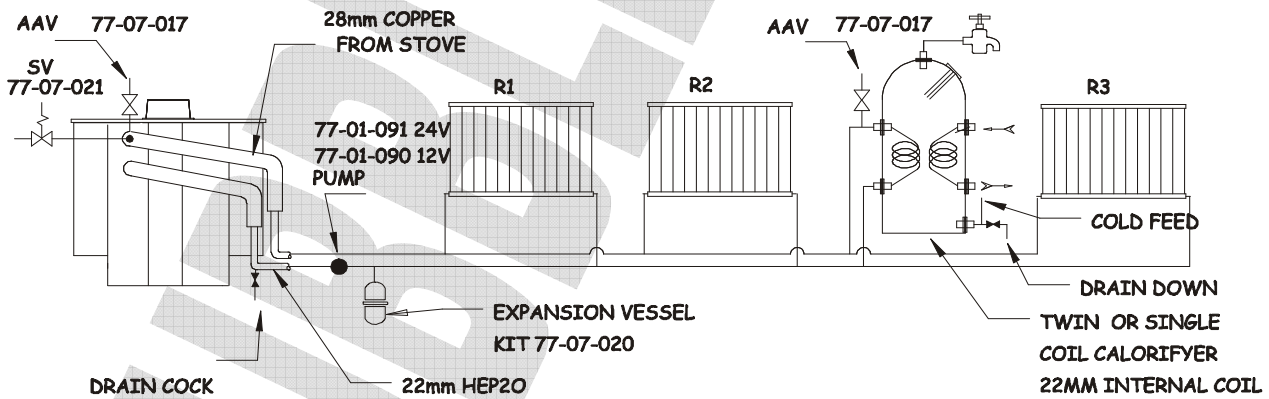

© HARWORTH HEATING LTD 30.6.98

This publication may not be copied by any means, without written permission from the authors.

This product is subject to continuous development and improvement and it is consequently acknowledged that due to this process there may be some omissions and errors.

This publication is intended only to assist the reader in the use of this product and therefore Harworth Heating Ltd shall not be liable for any loss or damage whatsoever arising from the use of any information, error or omission found in this guide.

Only approved personnel, WHO HAVE BEEN SUITABLY TRAINED, must carry out maintenance on this product.



CORNER OVEN OIL APPLIANCE

INSTALLER INSTRUCTIONS ISSUE 1 - 05-02-17

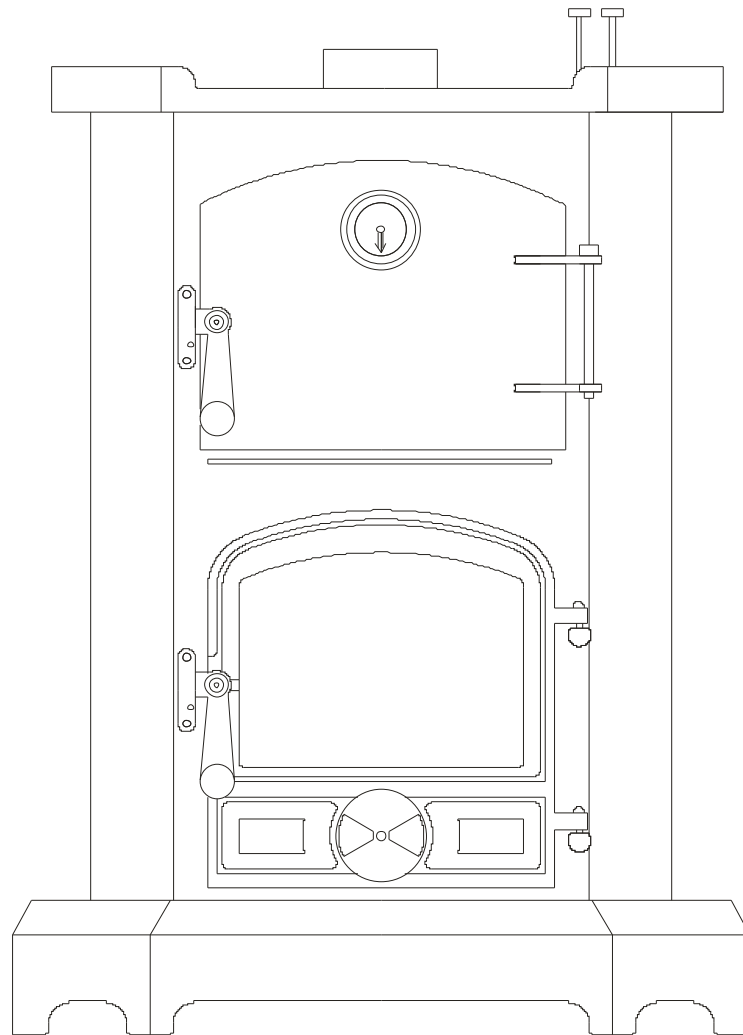

www.harworthheating.co.uk

INDEX

1. BEFORE STARTING THE JOB.	5
ABOUT THE APPLIANCE.....	5
CONTROLS.....	6
2. SAFETY	6
FUMES.....	6
FIRE.....	6
BURNS.....	7
CLEARANCES FROM COMBUSTIBLES (APPLIANCE).....	7
CLEARANCES FROM COMBUSTIBLES (FLUE).....	7
VENTILATION.....	7
IMPACT RESISTANCE.....	7
3. CHIMNEY	7
THE HEIGHT.....	7
THE DIAMETER.....	7
THE TEMPERATURE OF THE GASSES IN IT.....	7
THE RESISTANCE OF THE INNER SURFACE OF.....	7
THE FLUE PIPE OR PIPES.....	7
THE CHIMNEY RULES.....	7
4. FUEL SUPPLY. SEE FIG 4	8
WAXING.....	8
TRIM.....	8
TANK. SEE FIG 4.....	8
OIL LINE. SEE FIG 4.....	8
WATER CONTAMINATION.....	8
REMOTE SENSING FIREVALVE. FIG 4.....	8
ISOLATION VALVES. FIG 4.....	8
SLEEVING. FIG 4.....	9
5. FIREPLACE	9
THE HEARTH.....	9
FIREPROOFING.....	9
APPLIANCE FEATURES.....	9
FASTENING DOWN.....	9
6. FITTING DRY APPLIANCES	9
SELECT LOCATION.....	9
FIT OIL TANK. FIG 4.....	9
RUN OIL LINE. FIG 4.....	9
TRIAL FIREPLACE ASSEMBLY.....	9
TRY APPLIANCE IN POSTION.....	9
ESTABLISH FLUE POSITION.....	9
MARK AND CUT ROOF PLATE.....	9
FIT DECK FLANGE.....	9
FIT FIRESTOP SPACER.....	9
FIT CEILING PLATE.....	9
TRIAL FIT FIRE.....	9
TRIAL FIT EVERYTHING ELSE.....	9
IF IT ALL FITS REFIT IT PERMANENTLY.....	9
SELECT LOCATION.....	9
FIT OIL TANK. FIG 4.....	9

RUN OIL LINE. FIG 4	9
TRIAL FIREPLACE ASSEMBLY.....	9
TRY APPLIANCE IN POSITION.....	9
ESTABLISH FLUE POSITION.....	9
MARK OUT AND CUT THE ROOF PLATE.....	10
FIT DECK FLANGE.....	10
FIT FIRESTOP SPACER.....	10
FIT CEILING PLATE.....	10
ABOVE DECK EXTENSION.....	10
6. FITTING WET APPLIANCES.....	10
EASY ACCESS TO THE BOILER UNIONS.....	10
EASY ACCESS TO THE DRAIN DOWN VALVE.....	10
EASY ACCESS TO THE OIL CONNECTION.....	10
EASY ACCESS TO THE ISOLATION VALVE.....	10
CALORIFIERS. FIG 5	11
VENTING OF AIR. FIG 5	11
PUMPED SYSTEMS. FIG 5	11
SAFETY VALVE. FIG 5	11
WATER TREATMENT.....	11
DRAIN DOWN. FIG 5.....	11
CIRCULATING PUMP. FIG 5.....	11
7. COMMISSIONING.....	11
PRE FIRING CHECKS.....	11
FUEL SUPPLY. FIG 4	11
FUEL.....	11
FILTER. FIG 4.....	11
FIRE VALVE. FIG 4	12
THROUGH BULKHEAD. FIG 4	12
ISOLATION VALVE. FIG4.....	12
PURGING NEW OIL LINES. FIG 4	12
AIR LOCKING. FIG 4	12
ELECTRICAL.....	12
VENTILATION.....	12
HYDRAULIC SYSTEMS. SEE FIG 5.....	12
CHIMNEY SYSTEM.....	12
DISTANCES FROM COMBUSTIBLES.....	12
LIGHTING.....	12
BEFORE ATTEMPTING TO LIGHT THE APPLIANCE.....	12
COMMISSIONING THE HIGH AND LOW FIRE.....	13
CHECKING THE ACTION OF THE BUILT IN THERMOSTAT.....	13
8. FAULT FINDING HEATING SYSTEM.....	13
THE CIRCUIT DESIGN. FIG 5.....	13
AIR LOCKED CIRCULATING PUMP. FIG 5.....	13
AIR LOCKED SYSTEM PIPEWORK. FIG 5.....	14
INADEQUATE SYSTEM PRESSURE HEAD.....	14
INOPERATIVE CIRCULATING PUMP. FIG 5	14
INADEQUATE PIPE SIZEING. FIG 5.....	14
INADEQUATE CALORIFYER DESIGN. FIG 5	14
INADEQUATE APPLIANCE LOCATION.....	14
FLOW OF WATER THROUGH THE BOILER. FIG 5.....	14
WATER THROUGH THE CALORIFYER.....	14

FLOW OF WATER THROUGH THE RADIATORS.....	14
THE SYSTEM IS NOT OVER PUMPING.....	14
LACK OF PRESSURE RELEASE SAFETY VALVES.....	14
FEED AND EXPANSION.....	14
9. FAULT FINDING COMBUSTION.....	14
1. RACING.....	14
2. FLUE VACUUM.....	14
3. BURNER RUNS SOOTY.....	14
4. BURNER DOES NOT LIGHT EASILY.....	14
5. OIL WILL NOT ENTER THE POT.....	14
6. OIL SMELLS.....	14
7. DEFLOODING A FLOODED POT.....	14
8. OPERATING OIL FLOW RATES.....	14
10. ROUTINE MAINTENANCE.....	15
1. EVERY 4 WEEKS-:.....	15
2. AS REQUIRED -:.....	15
3. EVERY EIGHT WEEKS -:.....	15
4. EVERY 24 WEEKS-:.....	15
5. ONCE PER YEAR-:.....	15
6. EVERY TWO YEARS -:.....	15
7. AS REQUIRED -:.....	15
11. WARRANTY.....	15
12. WARRANTY ITEMS NOT COVERED.....	16
DOOR GLASS.....	16
LABOUR COSTS.....	16
TRAVELING COSTS.....	16
CONSEQUENTIAL LOSS.....	16
CONSEQUENTIAL DAMAGE.....	16
14. APPLIANCE DISTANCES FROM COMBUSTIBLES.....	16
15. FLUE PIPE DISTANCES FROM COMBUSTIBLES.....	16
16. OIL SUPPLY LAYOUT.....	17
17. PLUMBING LAYOUT OPTIONS.....	18

Read in conjunction with the appropriate:-

1. Oil control valve leaflet.

If you have any difficulties please phone our technical help line on:-

01302 742520 fax 01302 750573

e mail sales@oilappliances.co.uk.

www.oilappliances.co.uk

1. BEFORE STARTING THE JOB.

ABOUT THE APPLIANCE.

The corner oven appliance is a simple development of the corner oil appliance incorporating a small oven built directly on top of a corner oil appliance.

It is installed in the same way as the corner oil.

There are a few changes which are incorporated as follows:-

1. The drip tray has an adjustable plate mounted to it which can be used for levelling purposes.

Drip Tray and Adjuster Plate



Adjuster Plate Locking Fasteners



2. For maintenance purposes the oil control valve has been mounted on a removable plate which allows the valve to be removed from the appliance should the need arise.

To remove the valve, first remove the left and right hand side panels, then remove the oil feed pipe by

disconnecting at the descaling device and then undo the straight compression joint and then remove the oil feed pipe from the valve.

Undo the single locking screw, disconnect the oil flow control rod and the thermostat control rod from the oil control valve and the valve and plate should then slide out.

Removable valve mounting plate.



As per the Corner Oil stove, standard deck flanges and traditional chimney extensions can be used above deck but we do recommend the use of an anti downdraft terminal.

As per the Corner Oil stove the appliance will provide space or combined space and water heating plus cooking on dry models and limited cooking on boiler models.

There are two versions of the appliance, dry and wet. The dry version is designed for space heating and cooking.

The wet version is designed for space and water with limited cooking.

On the wet, boiler version, there are 4 x 1" BSP female sockets for connections to be made to the heating circuits as required at either side of the appliance.

The boiler is high water content and suitable for pumped or gravity systems, pressurised or open vented, provided that they are correctly designed.

OPERATING PRINCIPLES.

The appliance is designed as a continuous running space heater, which burns vaporized diesel fume in a controlled manner utilizing a chimney to discharge the products of combustion and a pumped or gravity fed oil supply.

Once ignition has occurred oil goes into the pot where

it is vaporised and burned at a steady and controlled rate via gravity flow, metered by the OIL CONTROL VALVE.

The oil flow can be controlled from minimum to maximum or any setting in between determined by where you set the oil flow control knob.

Air for combustion

is drawn into the vaporizing pot by the natural action of the negative pressure in the chimney and to allow the chimney to work correctly it is essential that there is adequate, unrestricted ventilation into the area where the appliance is situated and the flue system is warm enough to pull air through the burner in the appliance.

The amount of vapour that can be successfully burned is directly proportional to the amount of air that the chimney can draw into the pot and so to achieve adequate combustion a balanced and appropriate flow of both oil vapour and air is required.

CONTROLS.

The output of the appliance is regulated by the amount of oil for vaporization which is allowed to go into it and this function is controlled by the -:

OIL CONTROL VALVE (O.C.V.), which is situated at the right hand side of the appliance, behind the right hand side panel.

Turning the knob anti clockwise controls the oil flow. The knob is located at the top right hand side of the appliance and is calibrated from off position (fully clockwise) through 6 graduations to maximum.

Controls for the appliance will vary, depending on which valve is fitted to it.

The valve could be an OCI ships valve or a Toby valve and this should be specified with the order for the appliance.

The control for the dry appliance comprises-:

1. Oil flow control only.

The boiler version has extra controls which are-:

1. Oil flow control
2. Thermostat control
3. Safety Stat reset control

The Toby oil control valve only is used on boiler appliances. This valve has a built in, non electric, modulating thermostat control, which will put the fire on to low fire when the target temperature has been achieved.

In addition to this there is also a similar safety stat, which will shut the burner down, should the water exceed 80 deg C.

The safety stat re set control is lifted to reset the

valve, should the stat trip.

The Toby valve has to be tripped into action by lifting the trip button at the left hand side of the control panel.

The flow of oil into the pot can be adjusted via the knob on top of extension rod rising up from the oil control valve.

With the increased flow of oil, extra heat is generated, which in turn stimulates the chimney to work harder and consequently draw more air into the pot to maintain an adequate fuel air ratio.

2. SAFETY.

Take care to make sure that safety and ventilation issues are adequately addressed.

FUMES

When the appliance is first ignited, it may be necessary to warm the chimney and the base of the pot with a propane gun; this will get the cold air moving in the stack and allow the burner to draw in.

Under non starting cold chimney situations, here are the main causes of fume or smoke to leak from the appliance.

- The chimney is blocked.
- There are too many bends in the chimney.
- The above deck chimney extension is not high enough.
- The boat is moored in a position near to high buildings or trees and downdraughting is occurring.
- The chimney is not airtight.

FIRE.

Fire can be caused by a variety of potential danger points and because of the space limitation on boats; this risk is ever present and must be adequately assessed.

The main danger is the effects of heat from the appliance on combustible materials and boat occupants. Make sure that all combustibles are adequately protected from the effects of heat radiation.

The appliance must stand on a fireproof base as per the distance from combustibles table.

On appliances using the coal kit, the floor in front of the appliance must have suitable fire protection extending a minimum of 100mm in front of the appliance.

The appliance has built in rear heat shields and when the appliance is positioned in a suitable location there must be a space of 25mm clearance beyond the outer heat shield, to allow air to rise up and around the heat shields.

The rear of the upper oven is insulated and the insulation is covered by a metal heat shield type plate. **Do not remove the heat shields under any circumstances.**

BURNS.

During normal, day-to-day use, many parts of this appliance, pipe work, and chimney can become too hot to touch.

Where necessary, we recommend that suitable guards be fitted, to provide adequate protection from the heat generated by the appliance. Fireguards must comply with BS6539.

Always use heatproof gloves when working on or near to a hot appliance.

CLEARANCES FROM COMBUSTIBLES (APPLIANCE)

See table in 14.

CLEARANCES FROM COMBUSTIBLES (FLUE)

See table in 14.

VENTILATION.

Ventilation plays a vital role in the fitting and sighting of any appliance.

The provision of ventilation for this appliance is adequately covered by the requirements of the boat safety scheme.

25-cmsq. Minimum permanent ventilation, directly to outside air, must be provided for this appliance.

WARNINGS.

Never try to relight a hot appliance; wait until it has cooled down.

Hot oil vapour is explosive.

Never try to light a flooded pot.

When attempting to light an appliance, make sure that the pot is not flooded with oil by looking into the base of the burner.

If it is flooded remove the excess oil as per instructions in the faultfinding section.

The appliance must be securely fastened down so that it can resist impact or collision and it must be level in both directions.

The appliance must not be operated with the glass front door opened or cracked, or without the lighting port plug fitted.

Only Qualified persons can install unvented plumbing systems.

A suitable and serviceable fire extinguisher should always be readily accessible.

IMPACT RESISTANCE.

The appliance must be securely bolted down so that it can resist impact or collision and it must be level in both directions.

Two fixing brackets are provided; these should be fitted over the oil drip tray up stand and fastened down through the hole provided.

3. CHIMNEY.

The power, (*suck or vacuum the chimney can develop*) depends upon the following:-

THE HEIGHT.

THE DIAMETER.

THE TEMPERATURE OF THE GASSES IN IT.

THE RESISTANCE OF THE INNER SURFACE OF

THE FLUE PIPE OR PIPES.

It is obvious that on a boat all the above elements are in short supply.

Normally, we have low flues which are small in diameter and generally not very well insulated, coupled with all these problems we have an additional one, which is that the boat moves across constantly changing surroundings, through locks, into headwinds and crosswinds, all creating major opportunity for down draughting to occur.

Any bend in any part of the chimney or roughness on the internal chimney wall will slow down the velocity of rising gases and reduce the effectiveness of the chimney.

Any slight reduction in the flue gas temperature will reduce the chimney vacuum or pull, hence when the appliance is slowed down for all night burning, as the flue gas cools down the chimney vacuum reduces and as the chimney vacuum drops, the appliance may well start to burn sooty. This problem is highlighted even more during very cold weather when the chimney can cool down even faster.

THE CHIMNEY RULES.

1. Always use a top outlet for flue pipe take off.
2. Never put any sharp bends in the flue. (*To maintain a concentric fit, we will allow a slight kick off the appliance and a similar kick into the deck flange*).
3. Always try to get the appliance as low as possible in the boat, this will allow installation of maximum length flue pipe.
4. Always have two double walled, above deck extensions, short for cruising and long (28inch minimum) for mooring. Insulated extensions are a thing of the future but it is possible to fill the space using a vermiculite and cement mix sealed off with flexible fire putty or heat proof silicone.

5. Fit a rotary swinging cowl to each extension or make one interchangeable.
6. Clean or have the chimney cleaned regularly. (Frequency depends upon type of fuel and length of time used).
7. Flue pipes should leave the appliance vertically and go through the roof of the vessel vertically.
8. **Under no circumstances should straight flue pipes be wedged in to the stove flue collar at an any angle less than vertical.**

4. FUEL SUPPLY. SEE FIG 4

There are several problems relating to diesel fuel supply, which need be adequately addressed.

WAXING.

Cold weather waxing or thickening alters the flow characteristics of diesel.

An adequate fuel feed supply can turn into an inadequate one when the temperature starts to fall. The worst scenario is fuel feed pipe 50-60 feet long in 8mm dia pipe.

The best-case scenario is a fuel pipe 4 feet long in 10mm dia with insulated lagging.

TRIM.

A minimum pressure head of out 8" is required.

This head is measured from the base of the oil tank to the top of the oil control valve. In some cases this head can be affected by the ballast or trim of the boat.

Take great care to try out all the different ballast and trim possibilities to make sure that adequate oil feed is always available at the outlet end of the fuel pipe before it enters the oil control valve at the appliance.

TANK. SEE FIG 4

If the appliance is fitted at the bow of the boat, a bow tank is recommended.

The tank should comply with the requirements of the boat safety scheme and have:-

- A conveniently sized filler
- A means of venting.
- A conveniently located, easily visible, contents gauge.
- An isolation valve
- An easily replaceable cartridge filter.

Do not use glass filter bowls, they are not acceptable under the boat safety scheme.

Always add a suitable proprietary antifreeze additive

to the appliance fuel for wintertime running.

OIL LINE. SEE FIG 4

The oil feed line starts after the fuel filter and proceeds to the point of entry, which is where the oil line goes into the cab or saloon of the boat.

Where oil lines go through bulkheads, use correct bulkhead fittings.

The diameter of the oil line is dependant upon the length of run.

At this point it is necessary to fit a remote sensing fire valve, designed to shut off the oil supply, should a fire occur near to the appliance.

If the bubble appliance is fitted up to the first bulkhead it will be necessary to fit the isolation valve outside the cabin or saloon of the boat.

WATER CONTAMINATION.

Because of the high risk of fuel contamination with water, we strongly recommend the fitting of a high volume water trap in the oil supply line.

REMOTE SENSING FIREVALVE. FIG 4

The fire valve has a capillary tube on the end of which is a temperature sensitive phial, run the capillary tube with the oil line up to the appliance and carefully fit the sensing phial 15mm pipe clips in front of the drip tray on the fireplace hearth, directly in front of the combustion air restrictor.

Before it is fitted try the fender on the appliance to make sure that the fender does not foul the sensing phial.

The sensing phial may be visible through the bottom of the fender, to mask it, paint it with matt black paint available from our sales desk.

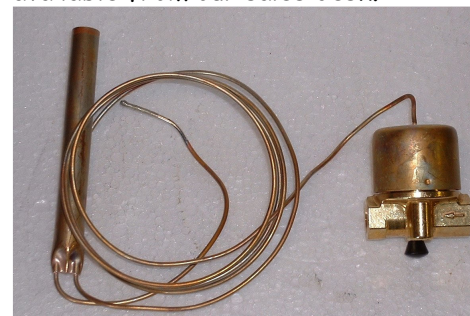

When fitting the fire valve make sure that where the capillary and oil line go through the bulkhead in separate sleeved tubes, so that the capillary can be withdrawn separately should it ever need replacing.

For fitting of long oil feed lines which pass through bulkheads and various other parts of the boat it may well be necessary to fit more than one fire valve, especially where the oil line passes through an area where a fire could occur i.e. kitchen area etc.

ISOLATION VALVES. FIG 4

Two isolation valves are required, one fitted directly into the oil control valve to allow you or the service man to turn the oil off should the need arise, and one on the oil tank fitted before the filter.

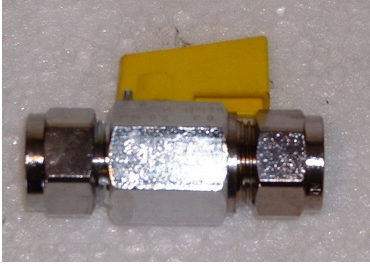

SLEEVING. FIG 4

Where the oil line goes through panels, a suitable sleeve must be fitted and sealed with a suitable sealant.

5. FIREPLACE.

Try to use materials, which are easy to keep clean and fireproof such as tiles, asbestolux, TAC board or vermiculite boarding.

THE HEARTH.

The hearth must be:-

FLAT - SECURE - FIREPROOF AND LEVEL IN BOTH DIRECTIONS.

See (Distance from combustibles.)

FIREPROOFING.

The vertical walls of the fireplace must be fireproofed, suitable materials would be tiles, asbestolux sheet, compressed vermiculite board.

APPLIANCE FEATURES.

The appliance has a base plate, which is designed to do two jobs,

- It acts as a drip tray to catch any oil spill.
- It acts as a spacer to set the appliance at a suitable distance from the vertical walls of the fireplace to allow adequate cooling air to flow around the oil valve.

FASTENING DOWN.

It is important to fix the base tray down to the hearth but don't drill through it as this will allow oil to leak from it should a spill occur. Clips to go over the top of the up stand are provided for this job.

6. FITTING DRY APPLIANCES.

SELECT LOCATION.

FIT OIL TANK. FIG 4

RUN OIL LINE. FIG 4

TRIAL FIREPLACE ASSEMBLY.

TRY APPLIANCE IN POSITION.

ESTABLISH FLUE POSITION.

MARK AND CUT ROOF PLATE.

FIT DECK FLANGE.

FIT FIRESTOP SPACER.

FIT CEILING PLATE.

TRIAL FIT FIRE.

TRIAL FIT EVERYTHING ELSE.

IF IT ALL FITS REFIT IT PERMANENTLY.

SELECT LOCATION.

The appliance can be located in any suitable corner. It and the flue system must be securely fastened, so as to withstand the normal day-to-day situations, which will be encountered in a narrow boat.

These could be:-

- Impact by other vessel.
- Impact into lock gate.
- The pitching and rolling effects of inland water sailing.
- Etc.

There are two angle brackets provided with the appliance, which hook over the front lip of the base tray and are screwed down to the hearth.

The location must have adequate protection from the effects of radiated and conducted heat as specified in section 4 and FIG1.

FIT OIL TANK. Fig 4

The oil tank will be fitted in the bow area and must comply with the requirements of the boat safety scheme. See schematic FIG 4.

RUN OIL LINE. FIG 4

Run the oil line and fit all the required components as described in sec 4 and shown in FIG 4.

TRIAL FIREPLACE ASSEMBLY.

The oil line and the fire valve sensor will have to pass through the fireplace, make sure that you make adequate provision for this and the remote sensing fire valve.

TRY APPLIANCE IN POSITION.

Try the appliance in position and make sure that the oil feed and remote sensing fire valve fit as required.

ESTABLISH FLUE POSITION.

Normally the appliance will be fitted in a corner, in a suitable fireplace; this will predict the angle at which

the flue pipe will have to be fitted.

The flue pipe will normally run at a slight angle to allow it to terminate through the ceiling, in a suitable position.

It is important to make sure that the flue fits concentrically at both the appliance end and as it passes through the fire stop spacer and deck flange. To achieve this the pipe will have to be marked out, notched and re-welded. Make a template to work from. When final fitting of the flue pipe occurs, make sure that the decorative top frame is fitted to the appliance, before the final fixing.

MARK OUT AND CUT THE ROOF PLATE.

FIT DECK FLANGE.

If you are going to use a standard deck flange for 6-inch extensions you will have to cut off the lower extension with a grinder to allow fitting of the fire stop spacer.

The deck flange will be bolted to the roof plate with a seal of silicone rubber applied between the joint.

The flue pipe provided with the appliance will be marked and trimmed off 10mm below the top of the deck flange to allow the flexible fire-cement to be flounced into a suitable taper.

The glass fibre rope will be wrapped around the flue pipe and gently pressed down on to the fire stop spacer, allow 10mm at the top of the joint and pack the gap with the flexible fire cement which will form a seal.

The deck flange will form the base for the traditional chimney extension to be fitted.

FIT FIRESTOP SPACER.

The fire stop space will be fitted in between the deck flange and the ceiling plate concentric to the flue access hole cut in the roof plate of the boat.

It will provide heat protection for any combustible materials located near to the through roof location.

The centre hole is cut deliberately undersize to accommodate differing flue sizes and angles.

It will be necessary to open up the centre hole to fit the flue pipe; this can be done by using the flue pipe as a template and carefully marking round it.

File the excess material away with a rough rasp. (Do this a little at a time to make sure that a good fit is achieved.)

The top surface of the spacer may also need trimming to provide a snug fit up to the inner surface of the roof steelwork.

FIT CEILING PLATE.

The ceiling plate will be fitted inside the boat to finish

off the through roof fitting of the flue pipe.

It will be screwed up to the trimming timber via 4 countersunk wood screws.

ABOVE DECK EXTENSION.

A traditional above deck extension can be fitted in line with normal practice.

We recommend that a short extension is used for cruising and a min 28" extension is used when mooring.

In each case we recommend the use of a rotating cowl to minimise the effects of down draught.

Fit the side panels 1 x left and 1 x right hand sides.

Fit the front fender.

6. FITTING WET APPLIANCES.

Installation of the wet appliance will be the same as the dry except that when dealing with the location an extra element comes in to the equation and that is connecting the appliance up to the heating circuit.

The appliance has a fully integral, powerful boiler, which forms the outer sides of the triangular shape and can be fitted to open vented or pressurised systems.

When connecting appliances to pressurised systems make sure that the Toby oil control valve and matching aqua stat are fitted.

Before designing the fireplace, take great care about making provision for the boiler connections and remember that the whole essence of the Corner Bubble is to make the finished job look like a piece of integrated design.

To facilitate removal of the appliance, make sure that there is

EASY ACCESS TO THE BOILER UNIONS.

EASY ACCESS TO THE DRAIN DOWN VALVE.

EASY ACCESS TO THE OIL CONNECTION.

EASY ACCESS TO THE ISOLATION VALVE.

Water can be connected to the appliance via 4 x 1 inch BSP female sockets, welded into the boiler at the rear top and bottom.

Alternative access to either side of the appliance, allows the installer to fit the appliance in either port or starboard locations.

Make sure that the vertical sides of the fireplace can easily accommodate the pipe work.

When installing water heating Bubble appliances, the space heating output will be reduced.

The boiler is high water content and suitable for pumped or gravity systems both open vented or pressurised.

If you are not suitably qualified, arrange for a heating engineer to do the design and fitting work for you. See FIG 5 for schematic layout.

CALORIFIERS. FIG 5

Indirect calorifiers must be used on gravity or pumped systems.

If you are going to install a gravity system you must make sure that you purchase a special calorifier with a 28 mm internal diameter coil, **don't be put off by suppliers who say that they have 28mm connections which are adequate, they are not as effective.**

On gravity systems the calorifiers must be located higher than the appliance and as close as possible to it, obviously keeping horizontal runs as short as possible.

VENTING OF AIR. FIG 5

Gravity or Pumped systems can be fitted with open vented or pressurised systems.

If open vented systems are used the feed and expansion tank must be as close as possible to the boiler and be fitted at the highest part of the circuit. Consult an experienced boat-heating engineer for advice on feed and expansion tanks.

To vent the system of air use automatic air vents on all possible air lock locations.

PIPE WORK. FIG 5

All gravity pipe work must rise on flow and fall on return and be a minimum of 28mm dia. (35mm dia preferred)

To reduce resistance to flow:-

- Use swept bends, do not use elbows.
- Use copper pipe work.
- Use high water content radiators.

The primary circuit must have a total length of not more than 6 meters otherwise the recovery time of the calorifier will be increased beyond an acceptable period of time.

Primary circuit pipe work must not have valves or other devices that can be used to interfere with the free flow of water.

PUMPED SYSTEMS. FIG 5

Always come off the appliance with 28mm copper for a minimum run of 350 mm before dropping on to 22mm hep 2o

To ensure suitable flow of water through the primaries a suitable injector tee should be used. Great care should be taken with the positioning of the circulating pump and the feed and expansion tank to make sure that the water flows where it should and that over pumping does not occur.

The heating circuit must be piped in 22mm copper or

Hep 2o with 15mm stabs to radiators.

Where additional radiators are fitted as heat leaks, the pipe work must be kept as short as possible, rise on feed and fall on return.

SAFETY VALVE. FIG 5

A 1" safety valve must be fitted as close to the boiler as possible (within 300mm) and the outlet from it must be directed to a safe location so as not to present any danger should the valve blow-off and exit steam or boiling water.

Note, safe location could be through the side of the boat, with a deflector to stop any horizontal emission.

WATER TREATMENT.

To reduce the build up of lime scale in the primary circuit pipe work the temperature of the water should not be allowed to exceed 65 Deg C and a suitable water treatment should be added.

If the boat is to be left unattended the water, in the heating system should also have suitable antifreeze added or be drained down.

DRAIN DOWN. FIG 5

A drain down valve should be fitted at the lowest point of the circuit.

CIRCULATING PUMP. FIG 5

On pumped systems make sure that the circulating pump is fitted in such a way as to make it easily replaceable, this means lock shielded valves at either side and easy access.

7. COMMISSIONING.

If the appliance has been fitted to an existing heating system, make sure that the system is adequately designed and complies with the details specified in this manual.

If the heating circuit does not comply, it must be modified, before attempting to light the appliance.

Commissioning takes the following form:

PRE FIRING CHECKS.

LIGHTING.

POST FIRING CHECKS AND ADJUSTMENTS.

PRE FIRING CHECKS.

FUEL SUPPLY. FIG 4

Tank, check for leaks-stability-height-position-vent. Check for leaks on the entire oil feed line from tank to appliance.

FUEL.

Check for correct grade.

FILTER. FIG 4

Is it fitted-check for function and leaks?
Oil line- check for function, positioning, material suitability and leaks.



FIRE VALVE. FIG 4
Check for function and leaks.

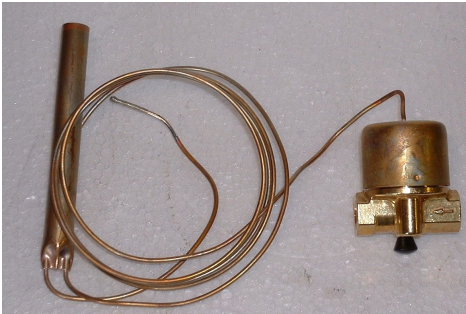

THROUGH BULKHEAD. FIG 4
Bulkhead fittings to be used.

ISOLATION VALVE. FIG4
Check for function, convenience of positioning and leaks.

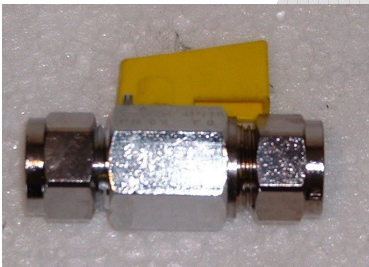

PURGING NEW OIL LINES. FIG 4
Flush at least 5 litres of oil through the line to check for contamination and to clear the oil line of installation debris and trapped air.

AIR LOCKING. FIG 4
Make sure that the oil feed supply pipe is level and has no potential for air locking. (Kinks, wavy runs, and sudden changes in level or slope).

ELECTRICAL.
Check for correct fusing, location and specification of any isolation devices.

VENTILATION.

Make sure that adequate ventilation is provided in line with boat safety scheme.

HYDRAULIC SYSTEMS. SEE FIG 5

Water systems should be pre-checked for leaks and tests must be made to make sure that water will flow freely through the boiler and that the boiler and pump is vented and free from trapped air.

Make sure that the heat leak circuit is adequate and unvalved.

CHIMNEY SYSTEM

Chimney heights must be a minimum of 1.8 meter for low fire use and 2.2 meter for high fire use.

Check the appliance is fitted with adequate clearances from combustibles.

Check that the combustion air restrictor is functioning correctly.

DISTANCES FROM COMBUSTIBLES

Make sure that both the appliance and flue system comply with the required distances from combustibles.

LIGHTING.

WARNING FOR BOILER APPLIANCES.

*If the appliance is fitted with a boiler, air locks or poor water flow through it may cause damage.
Make sure that the boiler has been vented of all air*

BEFORE ATTEMPTING TO LIGHT THE APPLIANCE.

Note; oven stoves are very efficient and as a consequence of this the flue pipe is slow to heat up. Most of the initial heat gets absorbed by the oven therefore before attempting to light the stove especially on a cold boat, it is advisable to pre heat both the burner pot and the flue pipe to make sure that the slug of cold air in the flue and appliance is rising and will allow air for combustion to be pulled into the burner pot. If the flue is not drawing air and the appliance is cold, fumes may well leak from the appliance and the ignition process can be long winded.

Lighting the appliance takes a little time and patience; the following procedure should be adopted.

Open the front door.

Remove the coal kit if it has been supplied with the appliance.

Remove the inner mesh catalyser



Turn the oil on at full rate and allow oil to flow into the bottom of the pot to form a pool about the size of a small digestive biscuit and then turn the oil off.

Do not allow any depth of oil to build up.

Light a small piece of firelighter (about the size of a pineapple chunk) and place it into the centre of the pot.

Replace the lower burning ring, the mesh catalyser and the coal kit and then leave the door slightly open whilst the firelighter gets the oil going.

If fume leaks out of the appliance this is a sign that the flue pipe is not hot enough and needs to be pre heated.

After 30 to 40 seconds, you will notice the flame start to establish itself and spread around the bottom of the pot.

When this occurs, close the door and turn the oil on to its minimum setting.

If the flame goes out or runs very sooty this is a sign that the flue is not hot enough.

After two or three minutes the flame should then slowly change from yellow into blue flame combustion and settle down to a steady burn.

Note there may be the occasional growl or audible vibration whilst the burner settles down into blue flame combustion.

Allow the burner 10 - 15 minutes to stabilise and the increase the flow of oil as required, moving by one increment of the dial only.

Do not leave the appliance unattended during the lighting and stabilising procedure.

COMMISSIONING THE HIGH AND LOW FIRE.

Adjustments should be made by reference to the oil valve booklet supplied with the appliance

Allow at least one hour for the chimney and appliance to warm up thoroughly before making any adjustments to the high or low fire screws.

When the burner has established good blue flame combustion turn it up to half output. (Setting 3 on the fuel flow control knob) and let it stabilize.

Turn the appliance down onto minimum firing rate and

let it stabilize.

After stabilization there should be a dull red glow in the catalyser with wispy blue flames flickering just over the top of it, approximately level with the top of the pot.

If the flame falls into a dirty rolling yellow flame and the catalyser is not dull red then the low fire will need to be increased until the burner can support the required blue flame combustion.

When you are happy with the low fire, set the high fire.

Turn the oil flow knob up to setting 4, let the flame stabilize, and look at it, if it is stable and blue, turn it up slowly using the control knob, letting it stabilize after each movement, *if the flame starts to go yellow with long flame combustion, it is running fuel rich and the high fire screw needs adjusting to reduce the flow of oil. (Screw the adjuster screw in to reduce the high fire oil flow.)*

Before adjusting the high fire screw, turn the flame down and let it stabilize in blue flame combustion, adjust the high fire screw by half a turn in and try turning the fuel flow up, if it is still fuel rich repeat the process until the high fire flame is running blue with flicks of yellow in the tips.

On the Socomef pot, the **high fire flame** will be set approx 40mm higher than the top of the pot.

CHECKING THE ACTION OF THE BUILT IN THERMOSTAT.

Boiler appliances have a thermostat assembly attached to the top of the oil control valve.

After the high and low fire has been set, check the action of the thermostat and overheat stat.

Do this by turning off the circulating pump and putting the appliance on to high fire.

As the boiler temperature increases the thermostat will shut the appliance down on to low fire, because the circulating pump is not working the boiler will carry on increasing temperature, at approx 80 deg C the safety stat will shut the oil valve down and the appliance will go out.

If this does not occur there could be a fault on the thermostat assembly.

8. FAULT FINDING HEATING SYSTEM.

If the system does not perform well check the following-:

THE CIRCUIT DESIGN. FIG 5

AIR LOCKED CIRCULATING PUMP. FIG 5

AIR LOCKED SYSTEM PIPEWORK. FIG 5

INADEQUATE SYSTEM PRESSURE HEAD.

INOPERATIVE CIRCULATING PUMP. FIG 5

INADEQUATE PIPE SIZING. FIG 5

INADEQUATE CALORIFYER DESIGN. FIG 5

INADEQUATE APPLIANCE LOCATION.

The appliance is fitted out of level, allowing an air pocket to build up in the top of the boiler, causing subsequent kettling and damage to thermostat sensing phial

FLOW OF WATER THROUGH THE BOILER. FIG 5

WATER THROUGH THE CALORIFYER.

FLOW OF WATER THROUGH THE RADIATORS.

THE SYSTEM IS NOT OVER PUMPING.

LACK OF PRESSURE RELEASE SAFETY VALVES.

FEED AND EXPANSION.

Is it fitted in the correct place?

9. FAULT FINDING COMBUSTION.

1. RACING.

1. Audible vibrations generated by the flame caused allowing by too much oil in the pot, too quickly.
1-1. Turn off the oil flow until the burner has settled down to a steady burn rate and then turn the fuel on again but don't let the flame go out otherwise the burner **MUST** be allowed to cool down fully before a re ignition is attempted.

2. FLUE VACUUM.

1. The pot type burner is extremely sensitive to flue vacuum variations.
2. Good combustion will not be possible unless our instructions on chimneys and flue vacuum are followed. See fig1
3. If the burner does not burn with a blue flame, recheck the chimney vacuum and oil flow rate.
4. If the burner does not run well check that the seals in the appliance are good and that there is no ingress of air into the appliance flue ways.
5. Check that the correct fuel oil is being used.
6. Check the levels.

3. BURNER RUNS SOOTY.

Comments made on this subject assume that the appliance has been running normally for some time. If the appliance soot's up this indicates that there is not adequate air for blue flame combustion or there is an excess of fuel.

Check that the chimney is working correctly. (This means pulling enough air into the burner to allow correct blue flame combustion to occur.

Check that the fuel is the correct type and quality. Check that the flow rates are correct.

Where burners are run at high fuel flow rates on low chimney vacuums, long unsatisfactory yellow flame combustion and bad sooting will occur.

To rectify this problem reduce the high fire flow rate screw on the Oil Control Valve until blue flame combustion occurs.

Never switch from low settings to high settings; a longer burner life will be achieved if the regulator is moved only by one number at a time leaving approx. one minute between each setting change.

4. BURNER DOES NOT LIGHT EASILY.

Read the instructions in the lighting section of this publication.

5. OIL WILL NOT ENTER THE POT.

Is there oil in the fuel tank?

Has the fire valve tripped?

Has the isolation valve been accidentally turned off?

Is the oil turned on at the oil flow control knob on the valve?

Is the oil feed pipe from the valve to the pot?

Blocked. (Unlikely)

Has the water stat tripped off on the aqua stat?

Has the aqua-stat been damaged by overheating.

To check this out, remove the aqua-stat from the valve and remove the phial from the boiler, re cock the valve and test fire the appliance. See Fig 4 Toby Valve document.

Note this type of damage is not covered by the warranty.

6. OIL SMELLS.

Visual check on all joints for obvious leaks.

Check that the descaling lever packing gland nut is adjusted.

7. DEFLOODING A FLOODED POT.

To carry out this procedure you will need -:

- a. A small leak proof plastic bag.
- b. A small sponge.
- c. A larger plastic bag for disposal of the residue.
- d. A pair of disposable plastic gloves.

If the pot becomes flooded, de flood it is as follows -:
Put a small plastic bag into the appliance and sponge from the pot into the bag, when the excess oil has been removed put the plastic bag and sponge into another plastic bag and dispose of it.

8. OPERATING OIL FLOW RATES.

OIL Flow rates in cc per minute.

Min	Max
4cc	10cc

Oil Flow Rates In litres per hour.

.24 litres	.6 litres
------------	-----------

Oil Flow Rates In litres per 24 hours.

5.76 litres	14.4 litres
-------------	-------------

Oil Flow Rates In litres per 7 x 24 hours.

40.32 litres	100.8 litres
--------------	--------------

10. ROUTINE MAINTENANCE.

Continuous running assumed.

1. EVERY 4 WEEKS-:

Operate the descaling lever by turning it completely two or three times.

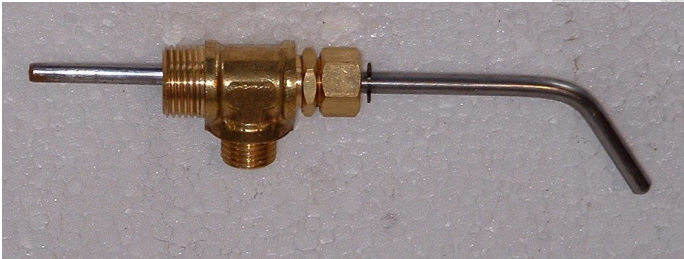

2. AS REQUIRED -:

Clean inside of door glass.

3. EVERY EIGHT WEEKS -:

Clean the burner completely by removing all the inner components as follows,

1. Open the front door.
 2. Remove the coal kit if it has been supplied with the appliance.
 3. Remove the inner mesh catalyser.
 4. Remove the lower burning ring.
- Scrape the bottom of the pot and remove all carbon build up.
Reassemble in the reverse order.

Corner appliance pot.



Section through corner appliance pot minus catalyser.

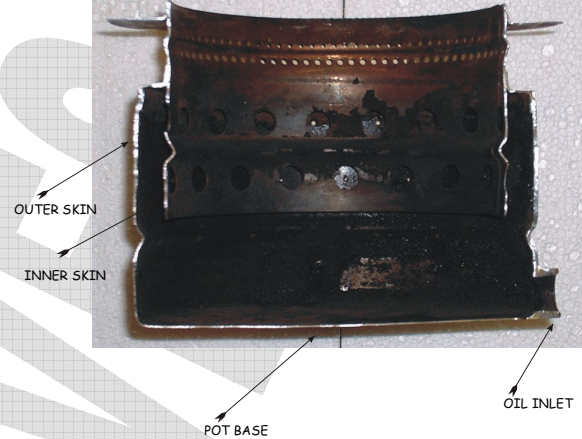

4. EVERY 24 WEEKS-:

4-1. Tighten up the compression nut on the descaling device to stop oil smells.

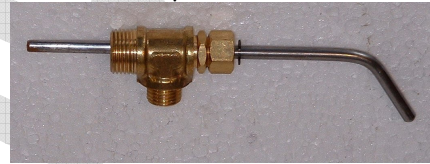

4-2. Section through descaling device.

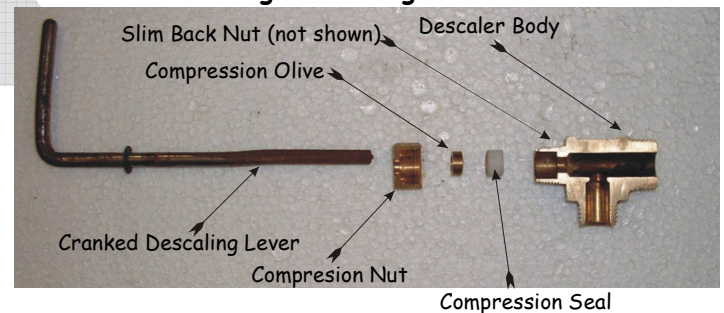

5. ONCE PER YEAR-:

Have your service man replace or clean all the filters in the oil supply line.

6. EVERY TWO YEARS -:

Have your service man clean the filter in the Oil Control Valve and check the function of all the safety equipment associated with the appliance, oil supply and plumbing system.

Remove and clean out the oil supply pipe from the valve to the pot.

7. AS REQUIRED -:

Keep the Coals, Coal kit, and burner inners in good condition, replace as necessary.

11. WARRANTY.

You are advised that if Harworth Heating Ltd is called out to appliances under warranty claims, where no

appliance fault can be found, charges will be made at the rate of £125.00 per hour, including travelling time.

Fill in the warranty form and returned it to us, the information recorded on the warranty form helps us to deal with any problems you may encounter.

Where we do not hold returned warranty forms replacement parts would only be issued when we are sure that the appliance has not been damaged by improper use or installation.

The warranty covers PARTS ONLY for a period of ONE YEAR and is conditional upon all the requirements

of our installation instructions being fully adhered to.

12. WARRANTY ITEMS NOT COVERED.

DOOR GLASS.

LABOUR COSTS.

TRAVELING COSTS.

CONSEQUENTIAL LOSS.

CONSEQUENTIAL DAMAGE.

14. APPLIANCE Distances from Combustibles

Appliance Type	ABOVE	BELOW	SIDES.	BACK	FRONT	HEARTH
BOAT B1	400	25	300	150 FROM HEAT SHIELD	400	25 THICK X 150
BOAT B2	400	25	300	150 FROM HEAT SHIELD	400	25 THICK X 150
BELFORT	400	25	300	150 FROM HEAT SHIELD	400	25 THICK X 150
CORNER	200	25	200	25 FROM HEAT SHIELD	300	25 THICK X 150
CORNER OVEN	150	15	200	25 FROM HEAT SHIELD	300	15THICK

ROUND	200	ALLOW 300 ALL AROUND THE APPLIANCE	25MM THICK HEARTH
-------	-----	------------------------------------	-------------------

Protection can be gained by the use of -:

- Sheet metal heat shields and spacers.
- Heat resistant boards.

Combustible materials can be-:

- Wooden furniture.
- Curtains.
- Wooden panels or frames adjacent to the flue pipe or where it passes through the deck of the boat.
- Carpet or flooring close to the appliance.
- Items near to the appliance, which could fall onto it and ignite, should the boat suffer a slight impact.

15. Flue Pipe Distances from Combustibles

For all appliances-:

150 for single skin pipes.

25 mm for insulated flue pipes.

16. Oil Supply Layout

FIG 4

CORNER STOVE OIL LAYOUT ISS 2

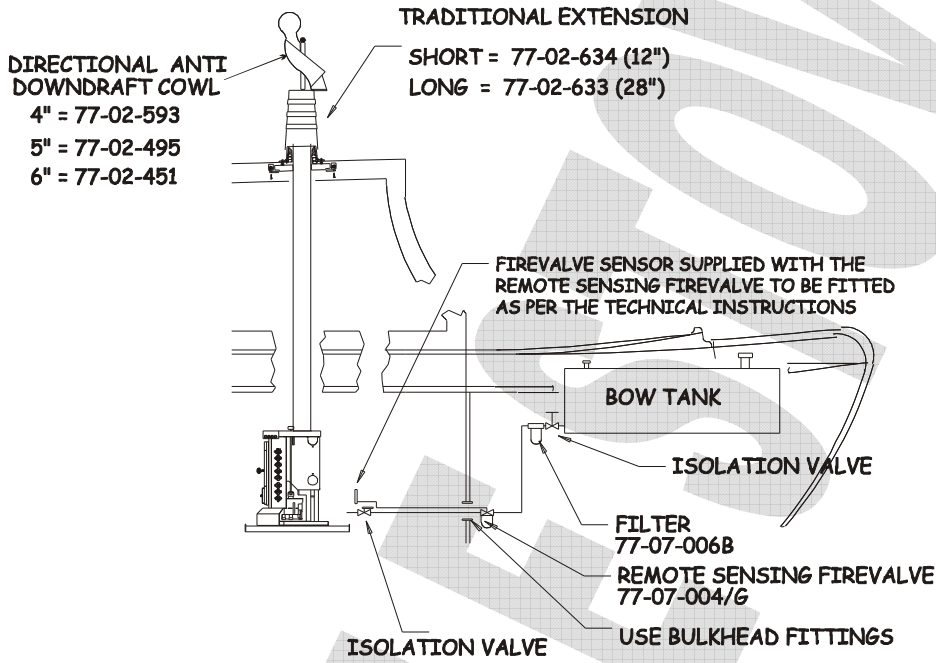

COPYRIGHT HARWORTH HEATING LTD 080800

17. Plumbing Layout Options

Each of the stoves has a different output to water and the installing engineer should first of all establish the boiler output to water and then design the heat losses accordingly.

Note that some of the boilers can only provide heat for a calorifier and towel rail.

FIG5

SCHMATIC GRAVITY SYSTEM ISS1 OF 08-07-01
READ IN CONJUNCTION WITH TECHNICAL INSTALLATION MANUAL

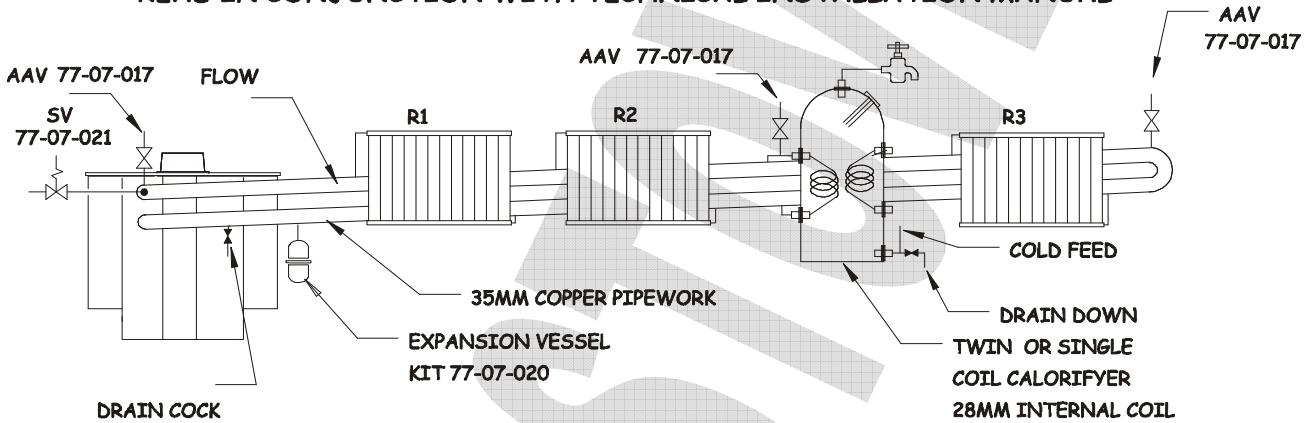

SCHMATIC PUMPED SYSTEM ISS1 OF 08-07-01

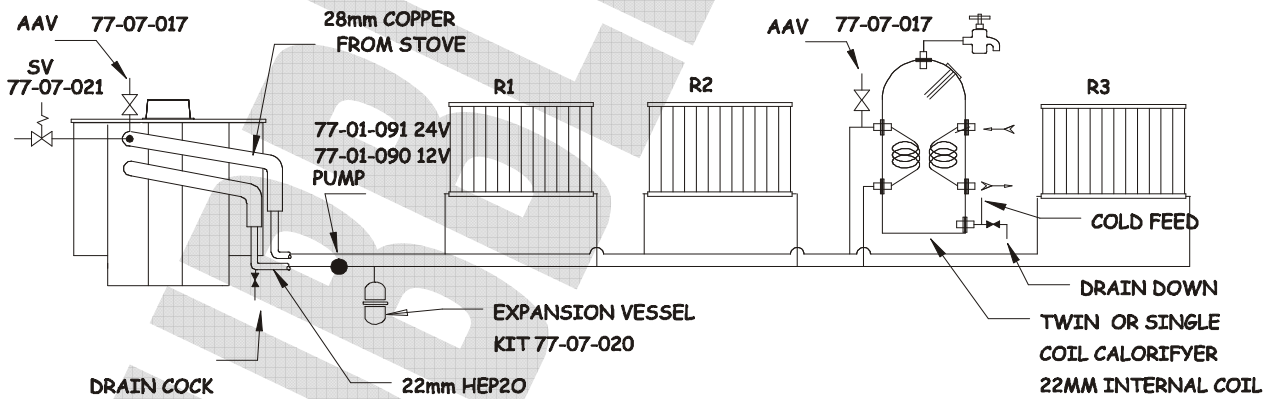

© HARWORTH HEATING LTD 30.6.98

This publication may not be copied by any means, without written permission from the authors.

This product is subject to continuous development and improvement and it is consequently acknowledged that due to this process there may be some omissions and errors.

This publication is intended only to assist the reader in the use of this product and therefore Harworth Heating Ltd shall not be liable for any loss or damage whatsoever arising from the use of any information, error or omission found in this guide.

Only approved personnel, WHO HAVE BEEN SUITABLY TRAINED, must carry out maintenance on this product.



CORNER OVEN OIL APPLIANCE

INSTALLER INSTRUCTIONS ISSUE 1 - 05-02-17

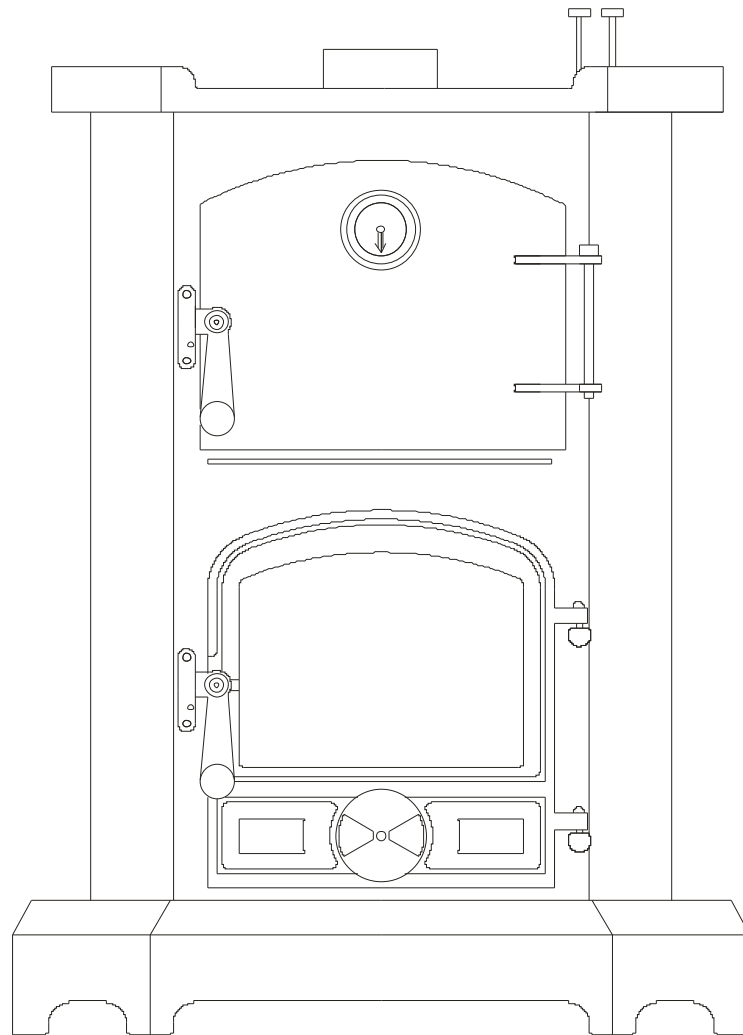

www.harworthheating.co.uk

INDEX

1. BEFORE STARTING THE JOB.	5
ABOUT THE APPLIANCE.....	5
CONTROLS.....	6
2. SAFETY	6
FUMES.....	6
FIRE.....	6
BURNS.....	7
CLEARANCES FROM COMBUSTIBLES (APPLIANCE).....	7
CLEARANCES FROM COMBUSTIBLES (FLUE).....	7
VENTILATION.....	7
IMPACT RESISTANCE.....	7
3. CHIMNEY	7
THE HEIGHT.....	7
THE DIAMETER.....	7
THE TEMPERATURE OF THE GASSES IN IT.....	7
THE RESISTANCE OF THE INNER SURFACE OF.....	7
THE FLUE PIPE OR PIPES.....	7
THE CHIMNEY RULES.....	7
4. FUEL SUPPLY. SEE FIG 4	8
WAXING.....	8
TRIM.....	8
TANK. SEE FIG 4.....	8
OIL LINE. SEE FIG 4.....	8
WATER CONTAMINATION.....	8
REMOTE SENSING FIREVALVE. FIG 4.....	8
ISOLATION VALVES. FIG 4.....	8
SLEEVING. FIG 4.....	9
5. FIREPLACE	9
THE HEARTH.....	9
FIREPROOFING.....	9
APPLIANCE FEATURES.....	9
FASTENING DOWN.....	9
6. FITTING DRY APPLIANCES	9
SELECT LOCATION.....	9
FIT OIL TANK. FIG 4.....	9
RUN OIL LINE. FIG 4.....	9
TRIAL FIREPLACE ASSEMBLY.....	9
TRY APPLIANCE IN POSTION.....	9
ESTABLISH FLUE POSITION.....	9
MARK AND CUT ROOF PLATE.....	9
FIT DECK FLANGE.....	9
FIT FIRESTOP SPACER.....	9
FIT CEILING PLATE.....	9
TRIAL FIT FIRE.....	9
TRIAL FIT EVERYTHING ELSE.....	9
IF IT ALL FITS REFIT IT PERMANENTLY.....	9
SELECT LOCATION.....	9
FIT OIL TANK. FIG 4.....	9

RUN OIL LINE. FIG 4	9
TRIAL FIREPLACE ASSEMBLY.....	9
TRY APPLIANCE IN POSITION.....	9
ESTABLISH FLUE POSITION.....	9
MARK OUT AND CUT THE ROOF PLATE.....	10
FIT DECK FLANGE.....	10
FIT FIRESTOP SPACER.....	10
FIT CEILING PLATE.....	10
ABOVE DECK EXTENSION.....	10
6. FITTING WET APPLIANCES.....	10
EASY ACCESS TO THE BOILER UNIONS.....	10
EASY ACCESS TO THE DRAIN DOWN VALVE.....	10
EASY ACCESS TO THE OIL CONNECTION.....	10
EASY ACCESS TO THE ISOLATION VALVE.....	10
CALORIFIERS. FIG 5	11
VENTING OF AIR. FIG 5	11
PUMPED SYSTEMS. FIG 5	11
SAFETY VALVE. FIG 5	11
WATER TREATMENT.....	11
DRAIN DOWN. FIG 5.....	11
CIRCULATING PUMP. FIG 5.....	11
7. COMMISSIONING.....	11
PRE FIRING CHECKS.....	11
FUEL SUPPLY. FIG 4	11
FUEL.....	11
FILTER. FIG 4.....	11
FIRE VALVE. FIG 4	12
THROUGH BULKHEAD. FIG 4	12
ISOLATION VALVE. FIG4.....	12
PURGING NEW OIL LINES. FIG 4	12
AIR LOCKING. FIG 4	12
ELECTRICAL.....	12
VENTILATION.....	12
HYDRAULIC SYSTEMS. SEE FIG 5.....	12
CHIMNEY SYSTEM.....	12
DISTANCES FROM COMBUSTIBLES.....	12
LIGHTING.....	12
BEFORE ATTEMPTING TO LIGHT THE APPLIANCE.....	12
COMMISSIONING THE HIGH AND LOW FIRE.....	13
CHECKING THE ACTION OF THE BUILT IN THERMOSTAT.....	13
8. FAULT FINDING HEATING SYSTEM.....	13
THE CIRCUIT DESIGN. FIG 5.....	13
AIR LOCKED CIRCULATING PUMP. FIG 5.....	13
AIR LOCKED SYSTEM PIPEWORK. FIG 5.....	14
INADEQUATE SYSTEM PRESSURE HEAD.....	14
INOPERATIVE CIRCULATING PUMP. FIG 5	14
INADEQUATE PIPE SIZEING. FIG 5.....	14
INADEQUATE CALORIFYER DESIGN. FIG 5	14
INADEQUATE APPLIANCE LOCATION.....	14
FLOW OF WATER THROUGH THE BOILER. FIG 5.....	14
WATER THROUGH THE CALORIFYER.....	14

FLOW OF WATER THROUGH THE RADIATORS.....	14
THE SYSTEM IS NOT OVER PUMPING.....	14
LACK OF PRESSURE RELEASE SAFETY VALVES.....	14
FEED AND EXPANSION.....	14
9. FAULT FINDING COMBUSTION.	14
1. RACING.....	14
2. FLUE VACUUM.....	14
3. BURNER RUNS SOOTY.....	14
4. BURNER DOES NOT LIGHT EASILY.....	14
5. OIL WILL NOT ENTER THE POT.....	14
6. OIL SMELLS.....	14
7. DEFLOODING A FLOODED POT.....	14
8. OPERATING OIL FLOW RATES.....	14
10. ROUTINE MAINTENANCE.....	15
1. EVERY 4 WEEKS-:.....	15
2. AS REQUIRED -:.....	15
3. EVERY EIGHT WEEKS -:.....	15
4. EVERY 24 WEEKS-:.....	15
5. ONCE PER YEAR-:.....	15
6. EVERY TWO YEARS -:.....	15
7. AS REQUIRED -:.....	15
11. WARRANTY.....	15
12. WARRANTY ITEMS NOT COVERED.....	16
DOOR GLASS.....	16
LABOUR COSTS.....	16
TRAVELING COSTS.....	16
CONSEQUENTIAL LOSS.....	16
CONSEQUENTIAL DAMAGE.....	16
14. APPLIANCE DISTANCES FROM COMBUSTIBLES.....	16
15. FLUE PIPE DISTANCES FROM COMBUSTIBLES.....	16
16. OIL SUPPLY LAYOUT.....	17
17. PLUMBING LAYOUT OPTIONS.....	18

Read in conjunction with the appropriate:-

1. Oil control valve leaflet.

If you have any difficulties please phone our technical help line on:-

01302 742520 fax 01302 750573

e mail sales@oilappliances.co.uk.

www.oilappliances.co.uk

1. BEFORE STARTING THE JOB.

ABOUT THE APPLIANCE.

The corner oven appliance is a simple development of the corner oil appliance incorporating a small oven built directly on top of a corner oil appliance.

It is installed in the same way as the corner oil.

There are a few changes which are incorporated as follows:-

1. The drip tray has an adjustable plate mounted to it which can be used for levelling purposes.

Drip Tray and Adjuster Plate



Adjuster Plate Locking Fasteners



2. For maintenance purposes the oil control valve has been mounted on a removable plate which allows the valve to be removed from the appliance should the need arise.

To remove the valve, first remove the left and right hand side panels, then remove the oil feed pipe by

disconnecting at the descaling device and then undo the straight compression joint and then remove the oil feed pipe from the valve.

Undo the single locking screw, disconnect the oil flow control rod and the thermostat control rod from the oil control valve and the valve and plate should then slide out.

Removable valve mounting plate.



As per the Corner Oil stove, standard deck flanges and traditional chimney extensions can be used above deck but we do recommend the use of an anti downdraft terminal.

As per the Corner Oil stove the appliance will provide space or combined space and water heating plus cooking on dry models and limited cooking on boiler models.

There are two versions of the appliance, dry and wet. The dry version is designed for space heating and cooking.

The wet version is designed for space and water with limited cooking.

On the wet, boiler version, there are 4 x 1" BSP female sockets for connections to be made to the heating circuits as required at either side of the appliance.

The boiler is high water content and suitable for pumped or gravity systems, pressurised or open vented, provided that they are correctly designed.

OPERATING PRINCIPLES.

The appliance is designed as a continuous running space heater, which burns vaporized diesel fume in a controlled manner utilizing a chimney to discharge the products of combustion and a pumped or gravity fed oil supply.

Once ignition has occurred oil goes into the pot where

it is vaporised and burned at a steady and controlled rate via gravity flow, metered by the OIL CONTROL VALVE.

The oil flow can be controlled from minimum to maximum or any setting in between determined by where you set the oil flow control knob.

Air for combustion

is drawn into the vaporizing pot by the natural action of the negative pressure in the chimney and to allow the chimney to work correctly it is essential that there is adequate, unrestricted ventilation into the area where the appliance is situated and the flue system is warm enough to pull air through the burner in the appliance.

The amount of vapour that can be successfully burned is directly proportional to the amount of air that the chimney can draw into the pot and so to achieve adequate combustion a balanced and appropriate flow of both oil vapour and air is required.

CONTROLS.

The output of the appliance is regulated by the amount of oil for vaporization which is allowed to go into it and this function is controlled by the -:

OIL CONTROL VALVE (O.C.V.), which is situated at the right hand side of the appliance, behind the right hand side panel.

Turning the knob anti clockwise controls the oil flow. The knob is located at the top right hand side of the appliance and is calibrated from off position (fully clockwise) through 6 graduations to maximum.

Controls for the appliance will vary, depending on which valve is fitted to it.

The valve could be an OCI ships valve or a Toby valve and this should be specified with the order for the appliance.

The control for the dry appliance comprises-:

1. Oil flow control only.

The boiler version has extra controls which are-:

1. Oil flow control
2. Thermostat control
3. Safety Stat reset control

The Toby oil control valve only is used on boiler appliances. This valve has a built in, non electric, modulating thermostat control, which will put the fire on to low fire when the target temperature has been achieved.

In addition to this there is also a similar safety stat, which will shut the burner down, should the water exceed 80 deg C.

The safety stat re set control is lifted to reset the

valve, should the stat trip.

The Toby valve has to be tripped into action by lifting the trip button at the left hand side of the control panel.

The flow of oil into the pot can be adjusted via the knob on top of extension rod rising up from the oil control valve.

With the increased flow of oil, extra heat is generated, which in turn stimulates the chimney to work harder and consequently draw more air into the pot to maintain an adequate fuel air ratio.

2. SAFETY.

Take care to make sure that safety and ventilation issues are adequately addressed.

FUMES

When the appliance is first ignited, it may be necessary to warm the chimney and the base of the pot with a propane gun; this will get the cold air moving in the stack and allow the burner to draw in.

Under non starting cold chimney situations, here are the main causes of fume or smoke to leak from the appliance.

- The chimney is blocked.
- There are too many bends in the chimney.
- The above deck chimney extension is not high enough.
- The boat is moored in a position near to high buildings or trees and downdraughting is occurring.
- The chimney is not airtight.

FIRE.

Fire can be caused by a variety of potential danger points and because of the space limitation on boats; this risk is ever present and must be adequately assessed.

The main danger is the effects of heat from the appliance on combustible materials and boat occupants. Make sure that all combustibles are adequately protected from the effects of heat radiation.

The appliance must stand on a fireproof base as per the distance from combustibles table.

On appliances using the coal kit, the floor in front of the appliance must have suitable fire protection extending a minimum of 100mm in front of the appliance.

The appliance has built in rear heat shields and when the appliance is positioned in a suitable location there must be a space of 25mm clearance beyond the outer heat shield, to allow air to rise up and around the heat shields.

The rear of the upper oven is insulated and the insulation is covered by a metal heat shield type plate. **Do not remove the heat shields under any circumstances.**

BURNS.

During normal, day-to-day use, many parts of this appliance, pipe work, and chimney can become too hot to touch.

Where necessary, we recommend that suitable guards be fitted, to provide adequate protection from the heat generated by the appliance. Fireguards must comply with BS6539.

Always use heatproof gloves when working on or near to a hot appliance.

CLEARANCES FROM COMBUSTIBLES (APPLIANCE)

See table in 14.

CLEARANCES FROM COMBUSTIBLES (FLUE)

See table in 14.

VENTILATION.

Ventilation plays a vital role in the fitting and sighting of any appliance.

The provision of ventilation for this appliance is adequately covered by the requirements of the boat safety scheme.

25-cmsq. Minimum permanent ventilation, directly to outside air, must be provided for this appliance.

WARNINGS.

Never try to relight a hot appliance; wait until it has cooled down.

Hot oil vapour is explosive.

Never try to light a flooded pot.

When attempting to light an appliance, make sure that the pot is not flooded with oil by looking into the base of the burner.

If it is flooded remove the excess oil as per instructions in the faultfinding section.

The appliance must be securely fastened down so that it can resist impact or collision and it must be level in both directions.

The appliance must not be operated with the glass front door opened or cracked, or without the lighting port plug fitted.

Only Qualified persons can install unvented plumbing systems.

A suitable and serviceable fire extinguisher should always be readily accessible.

IMPACT RESISTANCE.

The appliance must be securely bolted down so that it can resist impact or collision and it must be level in both directions.

Two fixing brackets are provided; these should be fitted over the oil drip tray up stand and fastened down through the hole provided.

3. CHIMNEY.

The power, (*suck or vacuum the chimney can develop*) depends upon the following:-

THE HEIGHT.

THE DIAMETER.

THE TEMPERATURE OF THE GASSES IN IT.

THE RESISTANCE OF THE INNER SURFACE OF

THE FLUE PIPE OR PIPES.

It is obvious that on a boat all the above elements are in short supply.

Normally, we have low flues which are small in diameter and generally not very well insulated, coupled with all these problems we have an additional one, which is that the boat moves across constantly changing surroundings, through locks, into headwinds and crosswinds, all creating major opportunity for down draughting to occur.

Any bend in any part of the chimney or roughness on the internal chimney wall will slow down the velocity of rising gases and reduce the effectiveness of the chimney.

Any slight reduction in the flue gas temperature will reduce the chimney vacuum or pull, hence when the appliance is slowed down for all night burning, as the flue gas cools down the chimney vacuum reduces and as the chimney vacuum drops, the appliance may well start to burn sooty. This problem is highlighted even more during very cold weather when the chimney can cool down even faster.

THE CHIMNEY RULES.

1. Always use a top outlet for flue pipe take off.
2. Never put any sharp bends in the flue. (*To maintain a concentric fit, we will allow a slight kick off the appliance and a similar kick into the deck flange*).
3. Always try to get the appliance as low as possible in the boat, this will allow installation of maximum length flue pipe.
4. Always have two double walled, above deck extensions, short for cruising and long (28inch minimum) for mooring. Insulated extensions are a thing of the future but it is possible to fill the space using a vermiculite and cement mix sealed off with flexible fire putty or heat proof silicone.

5. Fit a rotary swinging cowl to each extension or make one interchangeable.
6. Clean or have the chimney cleaned regularly. (Frequency depends upon type of fuel and length of time used).
7. Flue pipes should leave the appliance vertically and go through the roof of the vessel vertically.
8. **Under no circumstances should straight flue pipes be wedged in to the stove flue collar at an any angle less than vertical.**

4. FUEL SUPPLY. SEE FIG 4

There are several problems relating to diesel fuel supply, which need be adequately addressed.

WAXING.

Cold weather waxing or thickening alters the flow characteristics of diesel.

An adequate fuel feed supply can turn into an inadequate one when the temperature starts to fall. The worst scenario is fuel feed pipe 50-60 feet long in 8mm dia pipe.

The best-case scenario is a fuel pipe 4 feet long in 10mm dia with insulated lagging.

TRIM.

A minimum pressure head of out 8" is required.

This head is measured from the base of the oil tank to the top of the oil control valve. In some cases this head can be affected by the ballast or trim of the boat.

Take great care to try out all the different ballast and trim possibilities to make sure that adequate oil feed is always available at the outlet end of the fuel pipe before it enters the oil control valve at the appliance.

TANK. SEE FIG 4

If the appliance is fitted at the bow of the boat, a bow tank is recommended.

The tank should comply with the requirements of the boat safety scheme and have:-

- A conveniently sized filler
- A means of venting.
- A conveniently located, easily visible, contents gauge.
- An isolation valve
- An easily replaceable cartridge filter.

Do not use glass filter bowls, they are not acceptable under the boat safety scheme.

Always add a suitable proprietary antifreeze additive

to the appliance fuel for wintertime running.

OIL LINE. SEE FIG 4

The oil feed line starts after the fuel filter and proceeds to the point of entry, which is where the oil line goes into the cab or saloon of the boat.

Where oil lines go through bulkheads, use correct bulkhead fittings.

The diameter of the oil line is dependant upon the length of run.

At this point it is necessary to fit a remote sensing fire valve, designed to shut off the oil supply, should a fire occur near to the appliance.

If the bubble appliance is fitted up to the first bulkhead it will be necessary to fit the isolation valve outside the cabin or saloon of the boat.

WATER CONTAMINATION.

Because of the high risk of fuel contamination with water, we strongly recommend the fitting of a high volume water trap in the oil supply line.

REMOTE SENSING FIREVALVE. FIG 4

The fire valve has a capillary tube on the end of which is a temperature sensitive phial, run the capillary tube with the oil line up to the appliance and carefully fit the sensing phial 15mm pipe clips in front of the drip tray on the fireplace hearth, directly in front of the combustion air restrictor.

Before it is fitted try the fender on the appliance to make sure that the fender does not foul the sensing phial.

The sensing phial may be visible through the bottom of the fender, to mask it, paint it with matt black paint available from our sales desk.

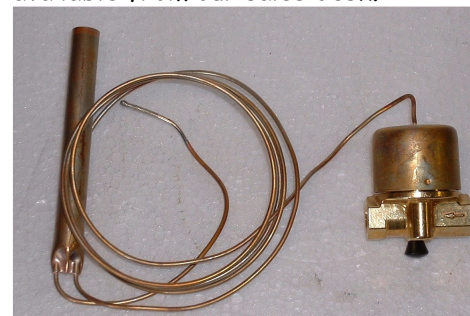

When fitting the fire valve make sure that where the capillary and oil line go through the bulkhead in separate sleeved tubes, so that the capillary can be withdrawn separately should it ever need replacing.

For fitting of long oil feed lines which pass through bulkheads and various other parts of the boat it may well be necessary to fit more than one fire valve, especially where the oil line passes through an area where a fire could occur i.e. kitchen area etc.

ISOLATION VALVES. FIG 4

Two isolation valves are required, one fitted directly into the oil control valve to allow you or the service man to turn the oil off should the need arise, and one on the oil tank fitted before the filter.

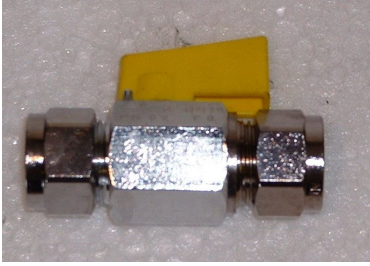

SLEEVING. FIG 4

Where the oil line goes through panels, a suitable sleeve must be fitted and sealed with a suitable sealant.

5. FIREPLACE.

Try to use materials, which are easy to keep clean and fireproof such as tiles, asbestolux, TAC board or vermiculite boarding.

THE HEARTH.

The hearth must be:-

FLAT - SECURE - FIREPROOF AND LEVEL IN BOTH DIRECTIONS.

See (Distance from combustibles.)

FIREPROOFING.

The vertical walls of the fireplace must be fireproofed, suitable materials would be tiles, asbestolux sheet, compressed vermiculite board.

APPLIANCE FEATURES.

The appliance has a base plate, which is designed to do two jobs,

- It acts as a drip tray to catch any oil spill.
- It acts as a spacer to set the appliance at a suitable distance from the vertical walls of the fireplace to allow adequate cooling air to flow around the oil valve.

FASTENING DOWN.

It is important to fix the base tray down to the hearth but don't drill through it as this will allow oil to leak from it should a spill occur. Clips to go over the top of the up stand are provided for this job.

6. FITTING DRY APPLIANCES.

SELECT LOCATION.

FIT OIL TANK. FIG 4

RUN OIL LINE. FIG 4

TRIAL FIREPLACE ASSEMBLY.

TRY APPLIANCE IN POSTION.

ESTABLISH FLUE POSITION.

MARK AND CUT ROOF PLATE.

FIT DECK FLANGE.

FIT FIRESTOP SPACER.

FIT CEILING PLATE.

TRIAL FIT FIRE.

TRIAL FIT EVERYTHING ELSE.

IF IT ALL FITS REFIT IT PERMANENTLY.

SELECT LOCATION.

The appliance can be located in any suitable corner. It and the flue system must be securely fastened, so as to withstand the normal day-to-day situations, which will be encountered in a narrow boat.

These could be:-

- Impact by other vessel.
- Impact into lock gate.
- The pitching and rolling effects of inland water sailing.
- Etc.

There are two angle brackets provided with the appliance, which hook over the front lip of the base tray and are screwed down to the hearth.

The location must have adequate protection from the effects of radiated and conducted heat as specified in section 4 and FIG1.

FIT OIL TANK. Fig 4

The oil tank will be fitted in the bow area and must comply with the requirements of the boat safety scheme. See schematic FIG 4.

RUN OIL LINE. FIG 4

Run the oil line and fit all the required components as described in sec 4 and shown in FIG 4.

TRIAL FIREPLACE ASSEMBLY.

The oil line and the fire valve sensor will have to pass through the fireplace, make sure that you make adequate provision for this and the remote sensing fire valve.

TRY APPLIANCE IN POSTION.

Try the appliance in position and make sure that the oil feed and remote sensing fire valve fit as required.

ESTABLISH FLUE POSITION.

Normally the appliance will be fitted in a corner, in a suitable fireplace; this will predict the angle at which

the flue pipe will have to be fitted.

The flue pipe will normally run at a slight angle to allow it to terminate through the ceiling, in a suitable position.

It is important to make sure that the flue fits concentrically at both the appliance end and as it passes through the fire stop spacer and deck flange. To achieve this the pipe will have to be marked out, notched and re-welded. Make a template to work from. When final fitting of the flue pipe occurs, make sure that the decorative top frame is fitted to the appliance, before the final fixing.

MARK OUT AND CUT THE ROOF PLATE.

FIT DECK FLANGE.

If you are going to use a standard deck flange for 6-inch extensions you will have to cut off the lower extension with a grinder to allow fitting of the fire stop spacer.

The deck flange will be bolted to the roof plate with a seal of silicone rubber applied between the joint.

The flue pipe provided with the appliance will be marked and trimmed off 10mm below the top of the deck flange to allow the flexible fire-cement to be flounced into a suitable taper.

The glass fibre rope will be wrapped around the flue pipe and gently pressed down on to the fire stop spacer, allow 10mm at the top of the joint and pack the gap with the flexible fire cement which will form a seal.

The deck flange will form the base for the traditional chimney extension to be fitted.

FIT FIRESTOP SPACER.

The fire stop space will be fitted in between the deck flange and the ceiling plate concentric to the flue access hole cut in the roof plate of the boat.

It will provide heat protection for any combustible materials located near to the through roof location.

The centre hole is cut deliberately undersize to accommodate differing flue sizes and angles.

It will be necessary to open up the centre hole to fit the flue pipe; this can be done by using the flue pipe as a template and carefully marking round it.

File the excess material away with a rough rasp. (Do this a little at a time to make sure that a good fit is achieved.)

The top surface of the spacer may also need trimming to provide a snug fit up to the inner surface of the roof steelwork.

FIT CEILING PLATE.

The ceiling plate will be fitted inside the boat to finish

off the through roof fitting of the flue pipe.

It will be screwed up to the trimming timber via 4 countersunk wood screws.

ABOVE DECK EXTENSION.

A traditional above deck extension can be fitted in line with normal practice.

We recommend that a short extension is used for cruising and a min 28" extension is used when mooring.

In each case we recommend the use of a rotating cowl to minimise the effects of down draught.

Fit the side panels 1 x left and 1 x right hand sides.

Fit the front fender.

6. FITTING WET APPLIANCES.

Installation of the wet appliance will be the same as the dry except that when dealing with the location an extra element comes in to the equation and that is connecting the appliance up to the heating circuit.

The appliance has a fully integral, powerful boiler, which forms the outer sides of the triangular shape and can be fitted to open vented or pressurised systems.

When connecting appliances to pressurised systems make sure that the Toby oil control valve and matching aqua stat are fitted.

Before designing the fireplace, take great care about making provision for the boiler connections and remember that the whole essence of the Corner Bubble is to make the finished job look like a piece of integrated design.

To facilitate removal of the appliance, make sure that there is

EASY ACCESS TO THE BOILER UNIONS.

EASY ACCESS TO THE DRAIN DOWN VALVE.

EASY ACCESS TO THE OIL CONNECTION.

EASY ACCESS TO THE ISOLATION VALVE.

Water can be connected to the appliance via 4 x 1 inch BSP female sockets, welded into the boiler at the rear top and bottom.

Alternative access to either side of the appliance, allows the installer to fit the appliance in either port or starboard locations.

Make sure that the vertical sides of the fireplace can easily accommodate the pipe work.

When installing water heating Bubble appliances, the space heating output will be reduced.

The boiler is high water content and suitable for pumped or gravity systems both open vented or pressurised.

If you are not suitably qualified, arrange for a heating engineer to do the design and fitting work for you. See FIG 5 for schematic layout.

CALORIFIERS. FIG 5

Indirect calorifiers must be used on gravity or pumped systems.

If you are going to install a gravity system you must make sure that you purchase a special calorifier with a 28 mm internal diameter coil, **don't be put off by suppliers who say that they have 28mm connections which are adequate, they are not as effective.**

On gravity systems the calorifiers must be located higher than the appliance and as close as possible to it, obviously keeping horizontal runs as short as possible.

VENTING OF AIR. FIG 5

Gravity or Pumped systems can be fitted with open vented or pressurised systems.

If open vented systems are used the feed and expansion tank must be as close as possible to the boiler and be fitted at the highest part of the circuit. Consult an experienced boat-heating engineer for advice on feed and expansion tanks.

To vent the system of air use automatic air vents on all possible air lock locations.

PIPE WORK. FIG 5

All gravity pipe work must rise on flow and fall on return and be a minimum of 28mm dia. (35mm dia preferred)

To reduce resistance to flow:-

- Use swept bends, do not use elbows.
- Use copper pipe work.
- Use high water content radiators.

The primary circuit must have a total length of not more than 6 meters otherwise the recovery time of the calorifier will be increased beyond an acceptable period of time.

Primary circuit pipe work must not have valves or other devices that can be used to interfere with the free flow of water.

PUMPED SYSTEMS. FIG 5

Always come off the appliance with 28mm copper for a minimum run of 350 mm before dropping on to 22mm hep 2o

To ensure suitable flow of water through the primaries a suitable injector tee should be used. Great care should be taken with the positioning of the circulating pump and the feed and expansion tank to make sure that the water flows where it should and that over pumping does not occur.

The heating circuit must be piped in 22mm copper or

Hep 2o with 15mm stabs to radiators.

Where additional radiators are fitted as heat leaks, the pipe work must be kept as short as possible, rise on feed and fall on return.

SAFETY VALVE. FIG 5

A 1" safety valve must be fitted as close to the boiler as possible (within 300mm) and the outlet from it must be directed to a safe location so as not to present any danger should the valve blow-off and exit steam or boiling water.

Note, safe location could be through the side of the boat, with a deflector to stop any horizontal emission.

WATER TREATMENT.

To reduce the build up of lime scale in the primary circuit pipe work the temperature of the water should not be allowed to exceed 65 Deg C and a suitable water treatment should be added.

If the boat is to be left unattended the water, in the heating system should also have suitable antifreeze added or be drained down.

DRAIN DOWN. FIG 5

A drain down valve should be fitted at the lowest point of the circuit.

CIRCULATING PUMP. FIG 5

On pumped systems make sure that the circulating pump is fitted in such a way as to make it easily replaceable, this means lock shielded valves at either side and easy access.

7. COMMISSIONING.

If the appliance has been fitted to an existing heating system, make sure that the system is adequately designed and complies with the details specified in this manual.

If the heating circuit does not comply, it must be modified, before attempting to light the appliance.

Commissioning takes the following form:

PRE FIRING CHECKS.

LIGHTING.

POST FIRING CHECKS AND ADJUSTMENTS.

PRE FIRING CHECKS.

FUEL SUPPLY. FIG 4

Tank, check for leaks-stability-height-position-vent. Check for leaks on the entire oil feed line from tank to appliance.

FUEL.

Check for correct grade.

FILTER. FIG 4

Is it fitted-check for function and leaks?
Oil line- check for function, positioning, material suitability and leaks.



FIRE VALVE. FIG 4
Check for function and leaks.

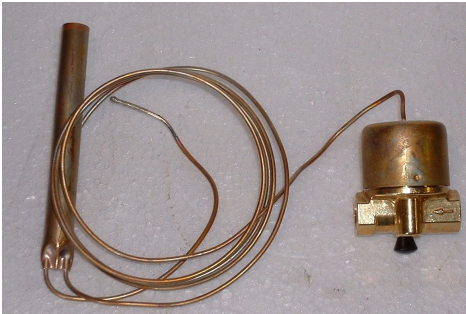

THROUGH BULKHEAD. FIG 4
Bulkhead fittings to be used.

ISOLATION VALVE. FIG4
Check for function, convenience of positioning and leaks.

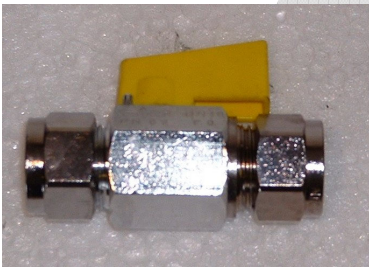

PURGING NEW OIL LINES. FIG 4
Flush at least 5 litres of oil through the line to check for contamination and to clear the oil line of installation debris and trapped air.

AIR LOCKING. FIG 4
Make sure that the oil feed supply pipe is level and has no potential for air locking. (Kinks, wavy runs, and sudden changes in level or slope).

ELECTRICAL.
Check for correct fusing, location and specification of any isolation devices.

VENTILATION.

Make sure that adequate ventilation is provided in line with boat safety scheme.

HYDRAULIC SYSTEMS. SEE FIG 5

Water systems should be pre-checked for leaks and tests must be made to make sure that water will flow freely through the boiler and that the boiler and pump is vented and free from trapped air.

Make sure that the heat leak circuit is adequate and unvalved.

CHIMNEY SYSTEM

Chimney heights must be a minimum of 1.8 meter for low fire use and 2.2 meter for high fire use.

Check the appliance is fitted with adequate clearances from combustibles.

Check that the combustion air restrictor is functioning correctly.

DISTANCES FROM COMBUSTIBLES

Make sure that both the appliance and flue system comply with the required distances from combustibles.

LIGHTING.

WARNING FOR BOILER APPLIANCES.

*If the appliance is fitted with a boiler, air locks or poor water flow through it may cause damage.
Make sure that the boiler has been vented of all air*

BEFORE ATTEMPTING TO LIGHT THE APPLIANCE.

Note; oven stoves are very efficient and as a consequence of this the flue pipe is slow to heat up. Most of the initial heat gets absorbed by the oven therefore before attempting to light the stove especially on a cold boat, it is advisable to pre heat both the burner pot and the flue pipe to make sure that the slug of cold air in the flue and appliance is rising and will allow air for combustion to be pulled into the burner pot. If the flue is not drawing air and the appliance is cold, fumes may well leak from the appliance and the ignition process can be long winded.

Lighting the appliance takes a little time and patience; the following procedure should be adopted.

Open the front door.

Remove the coal kit if it has been supplied with the appliance.

Remove the inner mesh catalyser



Turn the oil on at full rate and allow oil to flow into the bottom of the pot to form a pool about the size of a small digestive biscuit and then turn the oil off.

Do not allow any depth of oil to build up.

Light a small piece of firelighter (about the size of a pineapple chunk) and place it into the centre of the pot.

Replace the lower burning ring, the mesh catalyser and the coal kit and then leave the door slightly open whilst the firelighter gets the oil going.

If fume leaks out of the appliance this is a sign that the flue pipe is not hot enough and needs to be pre heated.

After 30 to 40 seconds, you will notice the flame start to establish itself and spread around the bottom of the pot.

When this occurs, close the door and turn the oil on to its minimum setting.

If the flame goes out or runs very sooty this is a sign that the flue is not hot enough.

After two or three minutes the flame should then slowly change from yellow into blue flame combustion and settle down to a steady burn.

Note there may be the occasional growl or audible vibration whilst the burner settles down into blue flame combustion.

Allow the burner 10 - 15 minutes to stabilise and the increase the flow of oil as required, moving by one increment of the dial only.

Do not leave the appliance unattended during the lighting and stabilising procedure.

COMMISSIONING THE HIGH AND LOW FIRE.

Adjustments should be made by reference to the oil valve booklet supplied with the appliance

Allow at least one hour for the chimney and appliance to warm up thoroughly before making any adjustments to the high or low fire screws.

When the burner has established good blue flame combustion turn it up to half output. (Setting 3 on the fuel flow control knob) and let it stabilize.

Turn the appliance down onto minimum firing rate and

let it stabilize.

After stabilization there should be a dull red glow in the catalyser with wispy blue flames flickering just over the top of it, approximately level with the top of the pot.

If the flame falls into a dirty rolling yellow flame and the catalyser is not dull red then the low fire will need to be increased until the burner can support the required blue flame combustion.

When you are happy with the low fire, set the high fire.

Turn the oil flow knob up to setting 4, let the flame stabilize, and look at it, if it is stable and blue, turn it up slowly using the control knob, letting it stabilize after each movement, *if the flame starts to go yellow with long flame combustion, it is running fuel rich and the high fire screw needs adjusting to reduce the flow of oil. (Screw the adjuster screw in to reduce the high fire oil flow.)*

Before adjusting the high fire screw, turn the flame down and let it stabilize in blue flame combustion, adjust the high fire screw by half a turn in and try turning the fuel flow up, if it is still fuel rich repeat the process until the high fire flame is running blue with flicks of yellow in the tips.

On the Socomef pot, the **high fire flame** will be set approx 40mm higher than the top of the pot.

CHECKING THE ACTION OF THE BUILT IN THERMOSTAT.

Boiler appliances have a thermostat assembly attached to the top of the oil control valve.

After the high and low fire has been set, check the action of the thermostat and overheat stat.

Do this by turning off the circulating pump and putting the appliance on to high fire.

As the boiler temperature increases the thermostat will shut the appliance down on to low fire, because the circulating pump is not working the boiler will carry on increasing temperature, at approx 80 deg C the safety stat will shut the oil valve down and the appliance will go out.

If this does not occur there could be a fault on the thermostat assembly.

8. FAULT FINDING HEATING SYSTEM.

If the system does not perform well check the following-:

THE CIRCUIT DESIGN. FIG 5

AIR LOCKED CIRCULATING PUMP. FIG 5

AIR LOCKED SYSTEM PIPEWORK. FIG 5

INADEQUATE SYSTEM PRESSURE HEAD.

INOPERATIVE CIRCULATING PUMP. FIG 5

INADEQUATE PIPE SIZING. FIG 5

INADEQUATE CALORIFYER DESIGN. FIG 5

INADEQUATE APPLIANCE LOCATION.

The appliance is fitted out of level, allowing an air pocket to build up in the top of the boiler, causing subsequent kettling and damage to thermostat sensing phial

FLOW OF WATER THROUGH THE BOILER. FIG 5

WATER THROUGH THE CALORIFYER.

FLOW OF WATER THROUGH THE RADIATORS.

THE SYSTEM IS NOT OVER PUMPING.

LACK OF PRESSURE RELEASE SAFETY VALVES.

FEED AND EXPANSION.

Is it fitted in the correct place?

9. FAULT FINDING COMBUSTION.

1. RACING.

1. Audible vibrations generated by the flame caused allowing by too much oil in the pot, too quickly.
1-1. Turn off the oil flow until the burner has settled down to a steady burn rate and then turn the fuel on again but don't let the flame go out otherwise the burner **MUST** be allowed to cool down fully before a re ignition is attempted.

2. FLUE VACUUM.

1. The pot type burner is extremely sensitive to flue vacuum variations.
2. Good combustion will not be possible unless our instructions on chimneys and flue vacuum are followed. See fig1
3. If the burner does not burn with a blue flame, recheck the chimney vacuum and oil flow rate.
4. If the burner does not run well check that the seals in the appliance are good and that there is no ingress of air into the appliance flue ways.
5. Check that the correct fuel oil is being used.
6. Check the levels.

3. BURNER RUNS SOOTY.

Comments made on this subject assume that the appliance has been running normally for some time. If the appliance soot's up this indicates that there is not adequate air for blue flame combustion or there is an excess of fuel.

Check that the chimney is working correctly. (This means pulling enough air into the burner to allow correct blue flame combustion to occur.

Check that the fuel is the correct type and quality.

Check that the flow rates are correct.

Where burners are run at high fuel flow rates on low chimney vacuums, long unsatisfactory yellow flame combustion and bad sooting will occur.

To rectify this problem reduce the high fire flow rate screw on the Oil Control Valve until blue flame combustion occurs.

Never switch from low settings to high settings; a longer burner life will be achieved if the regulator is moved only by one number at a time leaving approx. one minute between each setting change.

4. BURNER DOES NOT LIGHT EASILY.

Read the instructions in the lighting section of this publication.

5. OIL WILL NOT ENTER THE POT.

Is there oil in the fuel tank?

Has the fire valve tripped?

Has the isolation valve been accidentally turned off?

Is the oil turned on at the oil flow control knob on the valve?

Is the oil feed pipe from the valve to the pot?

Blocked. (Unlikely)

Has the water stat tripped off on the aqua stat?

Has the aqua-stat been damaged by overheating.

To check this out, remove the aqua-stat from the valve and remove the phial from the boiler, re cock the valve and test fire the appliance. See Fig 4 Toby Valve document.

Note this type of damage is not covered by the warranty.

6. OIL SMELLS.

Visual check on all joints for obvious leaks.

Check that the descaling lever packing gland nut is adjusted.

7. DEFLOODING A FLOODED POT.

To carry out this procedure you will need -:

- a. A small leak proof plastic bag.
- b. A small sponge.
- c. A larger plastic bag for disposal of the residue.
- d. A pair of disposable plastic gloves.

If the pot becomes flooded, de flood it is as follows -:
Put a small plastic bag into the appliance and sponge from the pot into the bag, when the excess oil has been removed put the plastic bag and sponge into another plastic bag and dispose of it.

8. OPERATING OIL FLOW RATES.

OIL Flow rates in cc per minute.

Min	Max
4cc	10cc

Oil Flow Rates In litres per hour.

.24 litres	.6 litres
------------	-----------

Oil Flow Rates In litres per 24 hours.

5.76 litres	14.4 litres
-------------	-------------

Oil Flow Rates In litres per 7 x 24 hours.

40.32 litres	100.8 litres
--------------	--------------

10. ROUTINE MAINTENANCE.

Continuous running assumed.

1. EVERY 4 WEEKS-:

Operate the descaling lever by turning it completely two or three times.

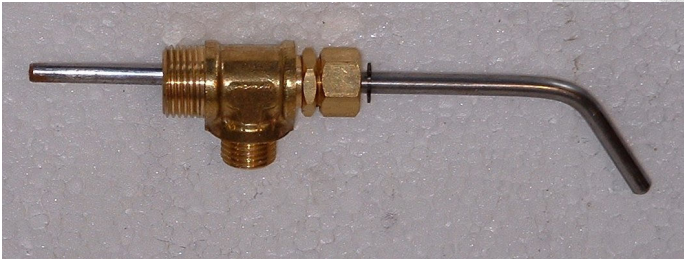

2. AS REQUIRED -:

Clean inside of door glass.

3. EVERY EIGHT WEEKS -:

Clean the burner completely by removing all the inner components as follows,

1. Open the front door.
 2. Remove the coal kit if it has been supplied with the appliance.
 3. Remove the inner mesh catalyser.
 4. Remove the lower burning ring.
- Scrape the bottom of the pot and remove all carbon build up.
Reassemble in the reverse order.

Corner appliance pot.



Section through corner appliance pot minus catalyser.

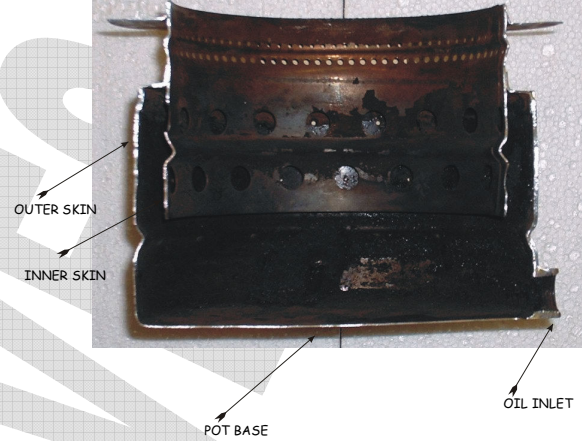

4. EVERY 24 WEEKS-:

4-1. Tighten up the compression nut on the descaling device to stop oil smells.

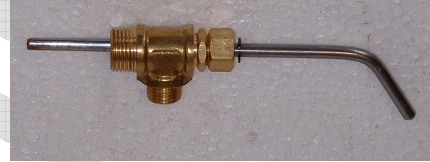

4-2. Section through descaling device.

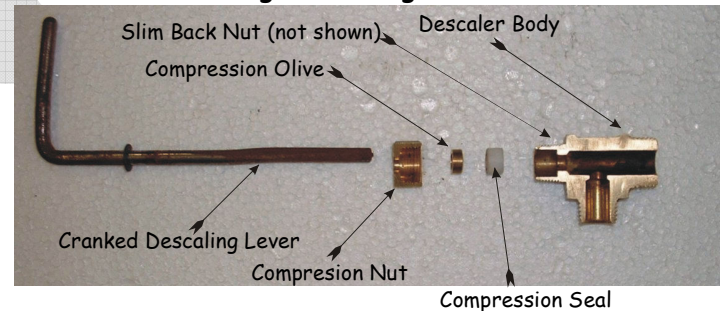

5. ONCE PER YEAR-:

Have your service man replace or clean all the filters in the oil supply line.

6. EVERY TWO YEARS -:

Have your service man clean the filter in the Oil Control Valve and check the function of all the safety equipment associated with the appliance, oil supply and plumbing system.
Remove and clean out the oil supply pipe from the valve to the pot.

7. AS REQUIRED -:

Keep the Coals, Coal kit, and burner inners in good condition, replace as necessary.

11. WARRANTY.

You are advised that if Harworth Heating Ltd is called out to appliances under warranty claims, where no

appliance fault can be found, charges will be made at the rate of £125.00 per hour, including travelling time.

Fill in the warranty form and returned it to us, the information recorded on the warranty form helps us to deal with any problems you may encounter.

Where we do not hold returned warranty forms replacement parts would only be issued when we are sure that the appliance has not been damaged by improper use or installation.

The warranty covers PARTS ONLY for a period of ONE YEAR and is conditional upon all the requirements

of our installation instructions being fully adhered to.

12. WARRANTY ITEMS NOT COVERED.

DOOR GLASS.

LABOUR COSTS.

TRAVELING COSTS.

CONSEQUENTIAL LOSS.

CONSEQUENTIAL DAMAGE.

14. APPLIANCE Distances from Combustibles

Appliance Type	ABOVE	BELOW	SIDES.	BACK	FRONT	HEARTH
BOAT B1	400	25	300	150 FROM HEAT SHIELD	400	25 THICK X 150
BOAT B2	400	25	300	150 FROM HEAT SHIELD	400	25 THICK X 150
BELFORT	400	25	300	150 FROM HEAT SHIELD	400	25 THICK X 150
CORNER	200	25	200	25 FROM HEAT SHIELD	300	25 THICK X 150
CORNER OVEN	150	15	200	25 FROM HEAT SHIELD	300	15THICK

ROUND	200	ALLOW 300 ALL AROUND THE APPLIANCE	25MM THICK HEARTH
-------	-----	------------------------------------	-------------------

Protection can be gained by the use of -:

- Sheet metal heat shields and spacers.
- Heat resistant boards.

Combustible materials can be-:

- Wooden furniture.
- Curtains.
- Wooden panels or frames adjacent to the flue pipe or where it passes through the deck of the boat.
- Carpet or flooring close to the appliance.
- Items near to the appliance, which could fall onto it and ignite, should the boat suffer a slight impact.

15. Flue Pipe Distances from Combustibles

For all appliances-:

150 for single skin pipes.

25 mm for insulated flue pipes.

16. Oil Supply Layout

FIG 4

CORNER STOVE OIL LAYOUT ISS 2

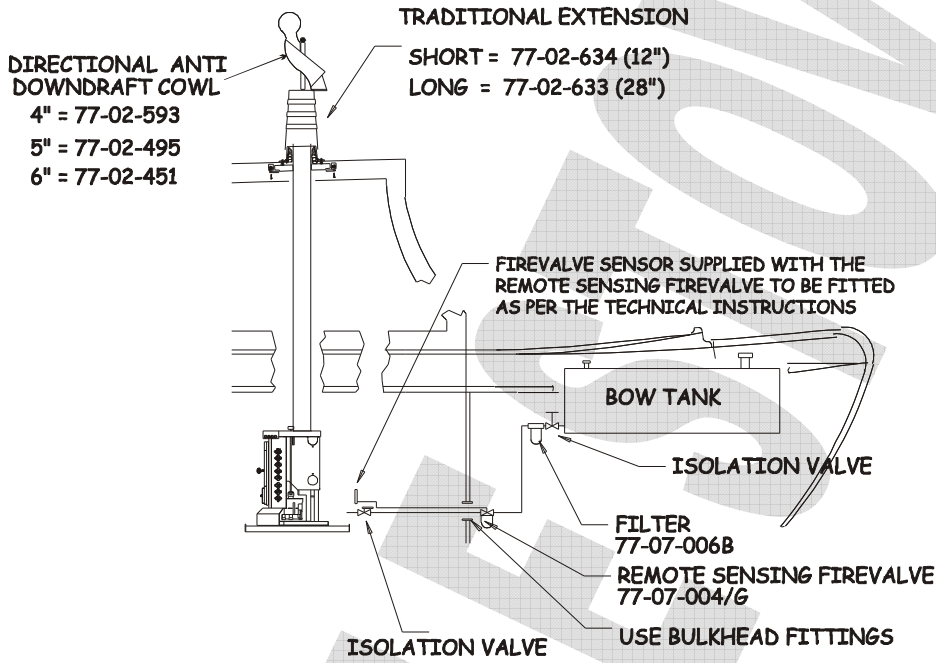

COPYRIGHT HARWORTH HEATING LTD 080800

17. Plumbing Layout Options

Each of the stoves has a different output to water and the installing engineer should first of all establish the boiler output to water and then design the heat losses accordingly.

Note that some of the boilers can only provide heat for a calorifier and towel rail.

FIG5

SCHMATIC GRAVITY SYSTEM ISS1 OF 08-07-01
READ IN CONJUNCTION WITH TECHNICAL INSTALLATION MANUAL

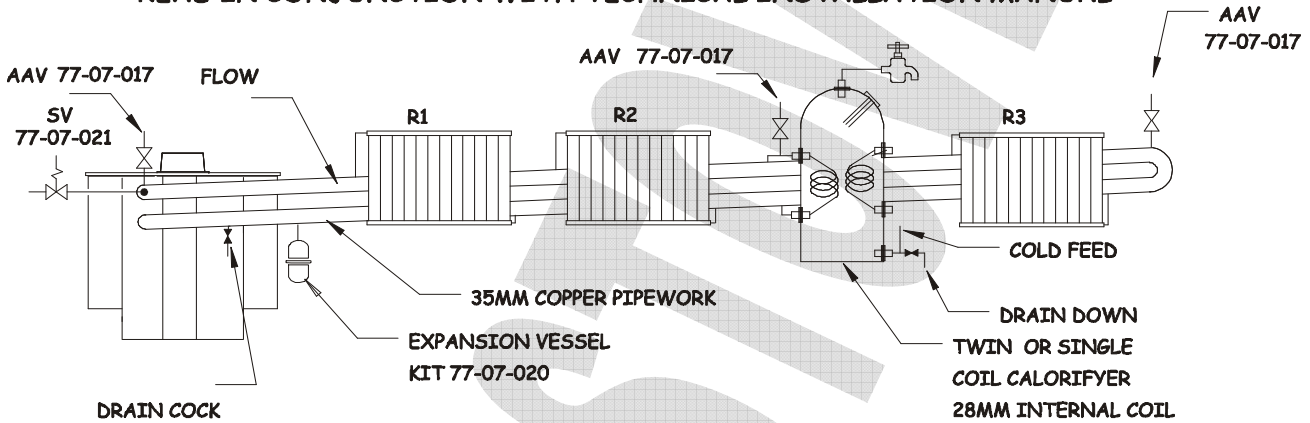

SCHMATIC PUMPED SYSTEM ISS1 OF 08-07-01

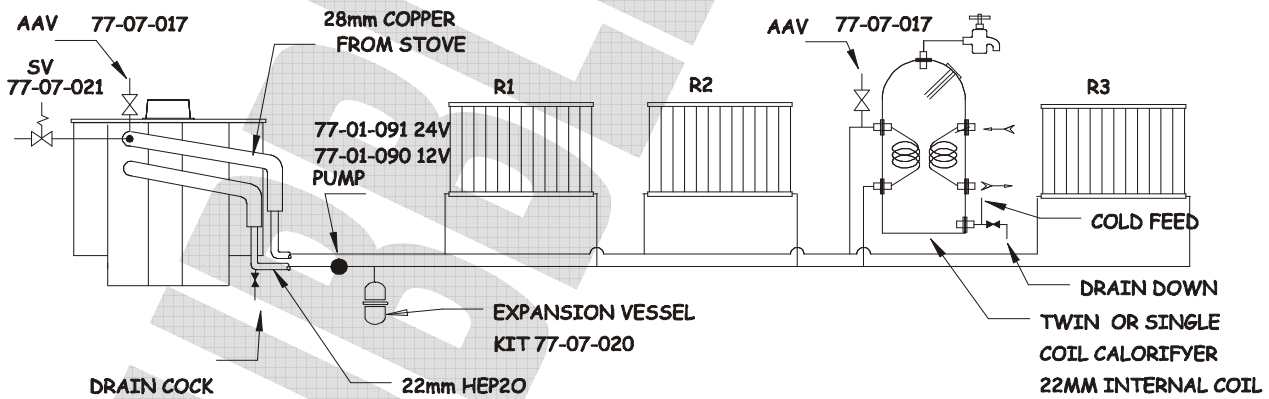

© HARWORTH HEATING LTD 30.6.98

This publication may not be copied by any means, without written permission from the authors.

This product is subject to continuous development and improvement and it is consequently acknowledged that due to this process there may be some omissions and errors.

This publication is intended only to assist the reader in the use of this product and therefore Harworth Heating Ltd shall not be liable for any loss or damage whatsoever arising from the use of any information, error or omission found in this guide.

Only approved personnel, WHO HAVE BEEN SUITABLY TRAINED, must carry out maintenance on this product.



CORNER OVEN OIL APPLIANCE

INSTALLER INSTRUCTIONS ISSUE 1 - 05-02-17

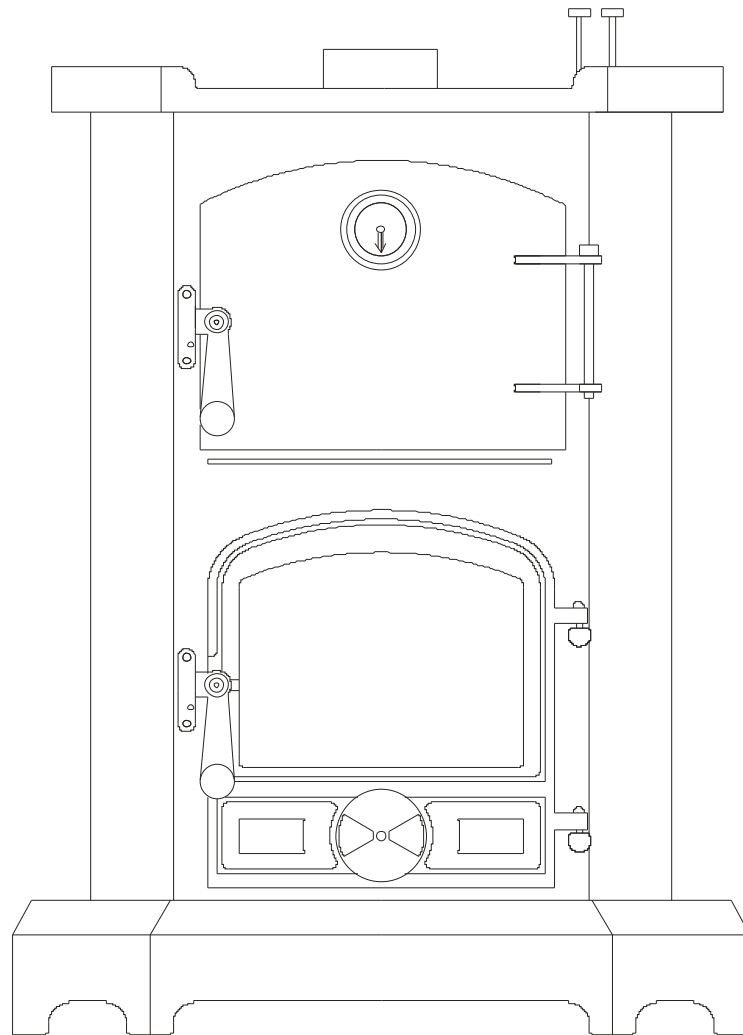

www.harworthheating.co.uk

INDEX

1. BEFORE STARTING THE JOB.	5
ABOUT THE APPLIANCE.....	5
CONTROLS.....	6
2. SAFETY	6
FUMES.....	6
FIRE.....	6
BURNS.....	7
CLEARANCES FROM COMBUSTIBLES (APPLIANCE).....	7
CLEARANCES FROM COMBUSTIBLES (FLUE).....	7
VENTILATION.....	7
IMPACT RESISTANCE.....	7
3. CHIMNEY	7
THE HEIGHT.....	7
THE DIAMETER.....	7
THE TEMPERATURE OF THE GASSES IN IT.....	7
THE RESISTANCE OF THE INNER SURFACE OF.....	7
THE FLUE PIPE OR PIPES.....	7
THE CHIMNEY RULES.....	7
4. FUEL SUPPLY. SEE FIG 4	8
WAXING.....	8
TRIM.....	8
TANK. SEE FIG 4.....	8
OIL LINE. SEE FIG 4.....	8
WATER CONTAMINATION.....	8
REMOTE SENSING FIREVALVE. FIG 4.....	8
ISOLATION VALVES. FIG 4.....	8
SLEEVING. FIG 4.....	9
5. FIREPLACE	9
THE HEARTH.....	9
FIREPROOFING.....	9
APPLIANCE FEATURES.....	9
FASTENING DOWN.....	9
6. FITTING DRY APPLIANCES	9
SELECT LOCATION.....	9
FIT OIL TANK. FIG 4.....	9
RUN OIL LINE. FIG 4.....	9
TRIAL FIREPLACE ASSEMBLY.....	9
TRY APPLIANCE IN POSTION.....	9
ESTABLISH FLUE POSITION.....	9
MARK AND CUT ROOF PLATE.....	9
FIT DECK FLANGE.....	9
FIT FIRESTOP SPACER.....	9
FIT CEILING PLATE.....	9
TRIAL FIT FIRE.....	9
TRIAL FIT EVERYTHING ELSE.....	9
IF IT ALL FITS REFIT IT PERMANENTLY.....	9
SELECT LOCATION.....	9
FIT OIL TANK. FIG 4.....	9

RUN OIL LINE. FIG 4	9
TRIAL FIREPLACE ASSEMBLY.....	9
TRY APPLIANCE IN POSITION.....	9
ESTABLISH FLUE POSITION.....	9
MARK OUT AND CUT THE ROOF PLATE.....	10
FIT DECK FLANGE.....	10
FIT FIRESTOP SPACER.....	10
FIT CEILING PLATE.....	10
ABOVE DECK EXTENSION.....	10
6. FITTING WET APPLIANCES.....	10
EASY ACCESS TO THE BOILER UNIONS.....	10
EASY ACCESS TO THE DRAIN DOWN VALVE.....	10
EASY ACCESS TO THE OIL CONNECTION.....	10
EASY ACCESS TO THE ISOLATION VALVE.....	10
CALORIFIERS. FIG 5	11
VENTING OF AIR. FIG 5	11
PUMPED SYSTEMS. FIG 5	11
SAFETY VALVE. FIG 5	11
WATER TREATMENT.....	11
DRAIN DOWN. FIG 5.....	11
CIRCULATING PUMP. FIG 5.....	11
7. COMMISSIONING.....	11
PRE FIRING CHECKS.....	11
FUEL SUPPLY. FIG 4	11
FUEL.....	11
FILTER. FIG 4.....	11
FIRE VALVE. FIG 4	12
THROUGH BULKHEAD. FIG 4	12
ISOLATION VALVE. FIG4.....	12
PURGING NEW OIL LINES. FIG 4	12
AIR LOCKING. FIG 4	12
ELECTRICAL.....	12
VENTILATION.....	12
HYDRAULIC SYSTEMS. SEE FIG 5.....	12
CHIMNEY SYSTEM.....	12
DISTANCES FROM COMBUSTIBLES.....	12
LIGHTING.....	12
BEFORE ATTEMPTING TO LIGHT THE APPLIANCE.....	12
COMMISSIONING THE HIGH AND LOW FIRE.....	13
CHECKING THE ACTION OF THE BUILT IN THERMOSTAT.....	13
8. FAULT FINDING HEATING SYSTEM.....	13
THE CIRCUIT DESIGN. FIG 5.....	13
AIR LOCKED CIRCULATING PUMP. FIG 5.....	13
AIR LOCKED SYSTEM PIPEWORK. FIG 5.....	14
INADEQUATE SYSTEM PRESSURE HEAD.....	14
INOPERATIVE CIRCULATING PUMP. FIG 5	14
INADEQUATE PIPE SIZEING. FIG 5.....	14
INADEQUATE CALORIFYER DESIGN. FIG 5	14
INADEQUATE APPLIANCE LOCATION.....	14
FLOW OF WATER THROUGH THE BOILER. FIG 5.....	14
WATER THROUGH THE CALORIFYER.....	14

FLOW OF WATER THROUGH THE RADIATORS.....	14
THE SYSTEM IS NOT OVER PUMPING.....	14
LACK OF PRESSURE RELEASE SAFETY VALVES.....	14
FEED AND EXPANSION.....	14
9. FAULT FINDING COMBUSTION.	14
1. RACING.....	14
2. FLUE VACUUM.....	14
3. BURNER RUNS SOOTY.....	14
4. BURNER DOES NOT LIGHT EASILY.....	14
5. OIL WILL NOT ENTER THE POT.....	14
6. OIL SMELLS.....	14
7. DEFLOODING A FLOODED POT.....	14
8. OPERATING OIL FLOW RATES.....	14
10. ROUTINE MAINTENANCE.....	15
1. EVERY 4 WEEKS-:.....	15
2. AS REQUIRED -:.....	15
3. EVERY EIGHT WEEKS -:.....	15
4. EVERY 24 WEEKS-:.....	15
5. ONCE PER YEAR-:.....	15
6. EVERY TWO YEARS -:.....	15
7. AS REQUIRED -:.....	15
11. WARRANTY.....	15
12. WARRANTY ITEMS NOT COVERED.....	16
DOOR GLASS.....	16
LABOUR COSTS.....	16
TRAVELING COSTS.....	16
CONSEQUENTIAL LOSS.....	16
CONSEQUENTIAL DAMAGE.....	16
14. APPLIANCE DISTANCES FROM COMBUSTIBLES.....	16
15. FLUE PIPE DISTANCES FROM COMBUSTIBLES.....	16
16. OIL SUPPLY LAYOUT.....	17
17. PLUMBING LAYOUT OPTIONS.....	18

Read in conjunction with the appropriate:-

1. Oil control valve leaflet.

If you have any difficulties please phone our technical help line on:-

01302 742520 fax 01302 750573

e mail sales@oilappliances.co.uk.

www.oilappliances.co.uk

1. BEFORE STARTING THE JOB.

ABOUT THE APPLIANCE.

The corner oven appliance is a simple development of the corner oil appliance incorporating a small oven built directly on top of a corner oil appliance.

It is installed in the same way as the corner oil.

There are a few changes which are incorporated as follows:-

1. The drip tray has an adjustable plate mounted to it which can be used for levelling purposes.

Drip Tray and Adjuster Plate



Adjuster Plate Locking Fasteners



2. For maintenance purposes the oil control valve has been mounted on a removable plate which allows the valve to be removed from the appliance should the need arise.

To remove the valve, first remove the left and right hand side panels, then remove the oil feed pipe by

disconnecting at the descaling device and then undo the straight compression joint and then remove the oil feed pipe from the valve.

Undo the single locking screw, disconnect the oil flow control rod and the thermostat control rod from the oil control valve and the valve and plate should then slide out.

Removable valve mounting plate.



As per the Corner Oil stove, standard deck flanges and traditional chimney extensions can be used above deck but we do recommend the use of an anti downdraft terminal.

As per the Corner Oil stove the appliance will provide space or combined space and water heating plus cooking on dry models and limited cooking on boiler models.

There are two versions of the appliance, dry and wet. The dry version is designed for space heating and cooking.

The wet version is designed for space and water with limited cooking.

On the wet, boiler version, there are 4 x 1" BSP female sockets for connections to be made to the heating circuits as required at either side of the appliance.

The boiler is high water content and suitable for pumped or gravity systems, pressurised or open vented, provided that they are correctly designed.

OPERATING PRINCIPLES.

The appliance is designed as a continuous running space heater, which burns vaporized diesel fume in a controlled manner utilizing a chimney to discharge the products of combustion and a pumped or gravity fed oil supply.

Once ignition has occurred oil goes into the pot where

it is vaporised and burned at a steady and controlled rate via gravity flow, metered by the OIL CONTROL VALVE.

The oil flow can be controlled from minimum to maximum or any setting in between determined by where you set the oil flow control knob.

Air for combustion

is drawn into the vaporizing pot by the natural action of the negative pressure in the chimney and to allow the chimney to work correctly it is essential that there is adequate, unrestricted ventilation into the area where the appliance is situated and the flue system is warm enough to pull air through the burner in the appliance.

The amount of vapour that can be successfully burned is directly proportional to the amount of air that the chimney can draw into the pot and so to achieve adequate combustion a balanced and appropriate flow of both oil vapour and air is required.

CONTROLS.

The output of the appliance is regulated by the amount of oil for vaporization which is allowed to go into it and this function is controlled by the -:

OIL CONTROL VALVE (O.C.V.), which is situated at the right hand side of the appliance, behind the right hand side panel.

Turning the knob anti clockwise controls the oil flow. The knob is located at the top right hand side of the appliance and is calibrated from off position (fully clockwise) through 6 graduations to maximum.

Controls for the appliance will vary, depending on which valve is fitted to it.

The valve could be an OCI ships valve or a Toby valve and this should be specified with the order for the appliance.

The control for the dry appliance comprises-:

1. Oil flow control only.

The boiler version has extra controls which are-:

1. Oil flow control
2. Thermostat control
3. Safety Stat reset control

The Toby oil control valve only is used on boiler appliances. This valve has a built in, non electric, modulating thermostat control, which will put the fire on to low fire when the target temperature has been achieved.

In addition to this there is also a similar safety stat, which will shut the burner down, should the water exceed 80 deg C.

The safety stat re set control is lifted to reset the

valve, should the stat trip.

The Toby valve has to be tripped into action by lifting the trip button at the left hand side of the control panel.

The flow of oil into the pot can be adjusted via the knob on top of extension rod rising up from the oil control valve.

With the increased flow of oil, extra heat is generated, which in turn stimulates the chimney to work harder and consequently draw more air into the pot to maintain an adequate fuel air ratio.

2. SAFETY.

Take care to make sure that safety and ventilation issues are adequately addressed.

FUMES

When the appliance is first ignited, it may be necessary to warm the chimney and the base of the pot with a propane gun; this will get the cold air moving in the stack and allow the burner to draw in.

Under non starting cold chimney situations, here are the main causes of fume or smoke to leak from the appliance.

- The chimney is blocked.
- There are too many bends in the chimney.
- The above deck chimney extension is not high enough.
- The boat is moored in a position near to high buildings or trees and downdraughting is occurring.
- The chimney is not airtight.

FIRE.

Fire can be caused by a variety of potential danger points and because of the space limitation on boats; this risk is ever present and must be adequately assessed.

The main danger is the effects of heat from the appliance on combustible materials and boat occupants. Make sure that all combustibles are adequately protected from the effects of heat radiation.

The appliance must stand on a fireproof base as per the distance from combustibles table.

On appliances using the coal kit, the floor in front of the appliance must have suitable fire protection extending a minimum of 100mm in front of the appliance.

The appliance has built in rear heat shields and when the appliance is positioned in a suitable location there must be a space of 25mm clearance beyond the outer heat shield, to allow air to rise up and around the heat shields.

The rear of the upper oven is insulated and the insulation is covered by a metal heat shield type plate. **Do not remove the heat shields under any circumstances.**

BURNS.

During normal, day-to-day use, many parts of this appliance, pipe work, and chimney can become too hot to touch.

Where necessary, we recommend that suitable guards be fitted, to provide adequate protection from the heat generated by the appliance. Fireguards must comply with BS6539.

Always use heatproof gloves when working on or near to a hot appliance.

CLEARANCES FROM COMBUSTIBLES (APPLIANCE)

See table in 14.

CLEARANCES FROM COMBUSTIBLES (FLUE)

See table in 14.

VENTILATION.

Ventilation plays a vital role in the fitting and sighting of any appliance.

The provision of ventilation for this appliance is adequately covered by the requirements of the boat safety scheme.

25-cmsq. Minimum permanent ventilation, directly to outside air, must be provided for this appliance.

WARNINGS.

Never try to relight a hot appliance; wait until it has cooled down.

Hot oil vapour is explosive.

Never try to light a flooded pot.

When attempting to light an appliance, make sure that the pot is not flooded with oil by looking into the base of the burner.

If it is flooded remove the excess oil as per instructions in the faultfinding section.

The appliance must be securely fastened down so that it can resist impact or collision and it must be level in both directions.

The appliance must not be operated with the glass front door opened or cracked, or without the lighting port plug fitted.

Only Qualified persons can install unvented plumbing systems.

A suitable and serviceable fire extinguisher should always be readily accessible.

IMPACT RESISTANCE.

The appliance must be securely bolted down so that it can resist impact or collision and it must be level in both directions.

Two fixing brackets are provided; these should be fitted over the oil drip tray up stand and fastened down through the hole provided.

3. CHIMNEY.

The power, (*suck or vacuum the chimney can develop*) depends upon the following:-

THE HEIGHT.

THE DIAMETER.

THE TEMPERATURE OF THE GASSES IN IT.

THE RESISTANCE OF THE INNER SURFACE OF

THE FLUE PIPE OR PIPES.

It is obvious that on a boat all the above elements are in short supply.

Normally, we have low flues which are small in diameter and generally not very well insulated, coupled with all these problems we have an additional one, which is that the boat moves across constantly changing surroundings, through locks, into headwinds and crosswinds, all creating major opportunity for down draughting to occur.

Any bend in any part of the chimney or roughness on the internal chimney wall will slow down the velocity of rising gases and reduce the effectiveness of the chimney.

Any slight reduction in the flue gas temperature will reduce the chimney vacuum or pull, hence when the appliance is slowed down for all night burning, as the flue gas cools down the chimney vacuum reduces and as the chimney vacuum drops, the appliance may well start to burn sooty. This problem is highlighted even more during very cold weather when the chimney can cool down even faster.

THE CHIMNEY RULES.

1. Always use a top outlet for flue pipe take off.
2. Never put any sharp bends in the flue. (*To maintain a concentric fit, we will allow a slight kick off the appliance and a similar kick into the deck flange*).
3. Always try to get the appliance as low as possible in the boat, this will allow installation of maximum length flue pipe.
4. Always have two double walled, above deck extensions, short for cruising and long (28inch minimum) for mooring. Insulated extensions are a thing of the future but it is possible to fill the space using a vermiculite and cement mix sealed off with flexible fire putty or heat proof silicone.

5. Fit a rotary swinging cowl to each extension or make one interchangeable.
6. Clean or have the chimney cleaned regularly. (Frequency depends upon type of fuel and length of time used).
7. Flue pipes should leave the appliance vertically and go through the roof of the vessel vertically.
8. **Under no circumstances should straight flue pipes be wedged in to the stove flue collar at an any angle less than vertical.**

4. FUEL SUPPLY. SEE FIG 4

There are several problems relating to diesel fuel supply, which need be adequately addressed.

WAXING.

Cold weather waxing or thickening alters the flow characteristics of diesel.

An adequate fuel feed supply can turn into an inadequate one when the temperature starts to fall. The worst scenario is fuel feed pipe 50-60 feet long in 8mm dia pipe.

The best-case scenario is a fuel pipe 4 feet long in 10mm dia with insulated lagging.

TRIM.

A minimum pressure head of out 8" is required.

This head is measured from the base of the oil tank to the top of the oil control valve. In some cases this head can be affected by the ballast or trim of the boat.

Take great care to try out all the different ballast and trim possibilities to make sure that adequate oil feed is always available at the outlet end of the fuel pipe before it enters the oil control valve at the appliance.

TANK. SEE FIG 4

If the appliance is fitted at the bow of the boat, a bow tank is recommended.

The tank should comply with the requirements of the boat safety scheme and have:-

- A conveniently sized filler
- A means of venting.
- A conveniently located, easily visible, contents gauge.
- An isolation valve
- An easily replaceable cartridge filter.

Do not use glass filter bowls, they are not acceptable under the boat safety scheme.

Always add a suitable proprietary antifreeze additive

to the appliance fuel for wintertime running.

OIL LINE. SEE FIG 4

The oil feed line starts after the fuel filter and proceeds to the point of entry, which is where the oil line goes into the cab or saloon of the boat.

Where oil lines go through bulkheads, use correct bulkhead fittings.

The diameter of the oil line is dependant upon the length of run.

At this point it is necessary to fit a remote sensing fire valve, designed to shut off the oil supply, should a fire occur near to the appliance.

If the bubble appliance is fitted up to the first bulkhead it will be necessary to fit the isolation valve outside the cabin or saloon of the boat.

WATER CONTAMINATION.

Because of the high risk of fuel contamination with water, we strongly recommend the fitting of a high volume water trap in the oil supply line.

REMOTE SENSING FIREVALVE. FIG 4

The fire valve has a capillary tube on the end of which is a temperature sensitive phial, run the capillary tube with the oil line up to the appliance and carefully fit the sensing phial 15mm pipe clips in front of the drip tray on the fireplace hearth, directly in front of the combustion air restrictor.

Before it is fitted try the fender on the appliance to make sure that the fender does not foul the sensing phial.

The sensing phial may be visible through the bottom of the fender, to mask it, paint it with matt black paint available from our sales desk.

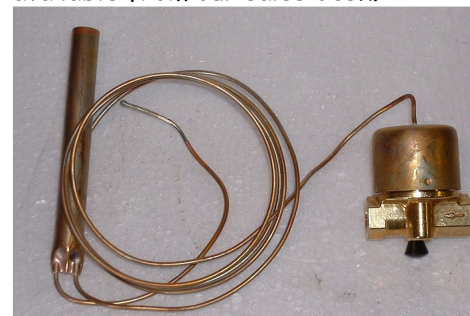

When fitting the fire valve make sure that where the capillary and oil line go through the bulkhead in separate sleeved tubes, so that the capillary can be withdrawn separately should it ever need replacing.

For fitting of long oil feed lines which pass through bulkheads and various other parts of the boat it may well be necessary to fit more than one fire valve, especially where the oil line passes through an area where a fire could occur i.e. kitchen area etc.

ISOLATION VALVES. FIG 4

Two isolation valves are required, one fitted directly into the oil control valve to allow you or the service man to turn the oil off should the need arise, and one on the oil tank fitted before the filter.

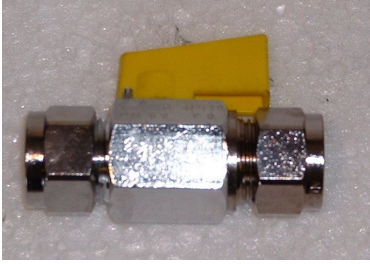

SLEEVING. FIG 4

Where the oil line goes through panels, a suitable sleeve must be fitted and sealed with a suitable sealant.

5. FIREPLACE.

Try to use materials, which are easy to keep clean and fireproof such as tiles, asbestolux, TAC board or vermiculite boarding.

THE HEARTH.

The hearth must be:-

FLAT - SECURE - FIREPROOF AND LEVEL IN BOTH DIRECTIONS.

See (Distance from combustibles.)

FIREPROOFING.

The vertical walls of the fireplace must be fireproofed, suitable materials would be tiles, asbestolux sheet, compressed vermiculite board.

APPLIANCE FEATURES.

The appliance has a base plate, which is designed to do two jobs,

- It acts as a drip tray to catch any oil spill.
- It acts as a spacer to set the appliance at a suitable distance from the vertical walls of the fireplace to allow adequate cooling air to flow around the oil valve.

FASTENING DOWN.

It is important to fix the base tray down to the hearth but don't drill through it as this will allow oil to leak from it should a spill occur. Clips to go over the top of the up stand are provided for this job.

6. FITTING DRY APPLIANCES.

SELECT LOCATION.

FIT OIL TANK. FIG 4

RUN OIL LINE. FIG 4

TRIAL FIREPLACE ASSEMBLY.

TRY APPLIANCE IN POSTION.

ESTABLISH FLUE POSITION.

MARK AND CUT ROOF PLATE.

FIT DECK FLANGE.

FIT FIRESTOP SPACER.

FIT CEILING PLATE.

TRIAL FIT FIRE.

TRIAL FIT EVERYTHING ELSE.

IF IT ALL FITS REFIT IT PERMANENTLY.

SELECT LOCATION.

The appliance can be located in any suitable corner. It and the flue system must be securely fastened, so as to withstand the normal day-to-day situations, which will be encountered in a narrow boat.

These could be:-

- Impact by other vessel.
- Impact into lock gate.
- The pitching and rolling effects of inland water sailing.
- Etc.

There are two angle brackets provided with the appliance, which hook over the front lip of the base tray and are screwed down to the hearth.

The location must have adequate protection from the effects of radiated and conducted heat as specified in section 4 and FIG1.

FIT OIL TANK. Fig 4

The oil tank will be fitted in the bow area and must comply with the requirements of the boat safety scheme. See schematic FIG 4.

RUN OIL LINE. FIG 4

Run the oil line and fit all the required components as described in sec 4 and shown in FIG 4.

TRIAL FIREPLACE ASSEMBLY.

The oil line and the fire valve sensor will have to pass through the fireplace, make sure that you make adequate provision for this and the remote sensing fire valve.

TRY APPLIANCE IN POSTION.

Try the appliance in position and make sure that the oil feed and remote sensing fire valve fit as required.

ESTABLISH FLUE POSITION.

Normally the appliance will be fitted in a corner, in a suitable fireplace; this will predict the angle at which

the flue pipe will have to be fitted.

The flue pipe will normally run at a slight angle to allow it to terminate through the ceiling, in a suitable position.

It is important to make sure that the flue fits concentrically at both the appliance end and as it passes through the fire stop spacer and deck flange. To achieve this the pipe will have to be marked out, notched and re-welded. Make a template to work from. When final fitting of the flue pipe occurs, make sure that the decorative top frame is fitted to the appliance, before the final fixing.

MARK OUT AND CUT THE ROOF PLATE.

FIT DECK FLANGE.

If you are going to use a standard deck flange for 6-inch extensions you will have to cut off the lower extension with a grinder to allow fitting of the fire stop spacer.

The deck flange will be bolted to the roof plate with a seal of silicone rubber applied between the joint.

The flue pipe provided with the appliance will be marked and trimmed off 10mm below the top of the deck flange to allow the flexible fire-cement to be flounced into a suitable taper.

The glass fibre rope will be wrapped around the flue pipe and gently pressed down on to the fire stop spacer, allow 10mm at the top of the joint and pack the gap with the flexible fire cement which will form a seal.

The deck flange will form the base for the traditional chimney extension to be fitted.

FIT FIRESTOP SPACER.

The fire stop space will be fitted in between the deck flange and the ceiling plate concentric to the flue access hole cut in the roof plate of the boat.

It will provide heat protection for any combustible materials located near to the through roof location.

The centre hole is cut deliberately undersize to accommodate differing flue sizes and angles.

It will be necessary to open up the centre hole to fit the flue pipe; this can be done by using the flue pipe as a template and carefully marking round it.

File the excess material away with a rough rasp. (Do this a little at a time to make sure that a good fit is achieved.)

The top surface of the spacer may also need trimming to provide a snug fit up to the inner surface of the roof steelwork.

FIT CEILING PLATE.

The ceiling plate will be fitted inside the boat to finish

off the through roof fitting of the flue pipe.

It will be screwed up to the trimming timber via 4 countersunk wood screws.

ABOVE DECK EXTENSION.

A traditional above deck extension can be fitted in line with normal practice.

We recommend that a short extension is used for cruising and a min 28" extension is used when mooring.

In each case we recommend the use of a rotating cowl to minimise the effects of down draught.

Fit the side panels 1 x left and 1 x right hand sides.

Fit the front fender.

6. FITTING WET APPLIANCES.

Installation of the wet appliance will be the same as the dry except that when dealing with the location an extra element comes in to the equation and that is connecting the appliance up to the heating circuit.

The appliance has a fully integral, powerful boiler, which forms the outer sides of the triangular shape and can be fitted to open vented or pressurised systems.

When connecting appliances to pressurised systems make sure that the Toby oil control valve and matching aqua stat are fitted.

Before designing the fireplace, take great care about making provision for the boiler connections and remember that the whole essence of the Corner Bubble is to make the finished job look like a piece of integrated design.

To facilitate removal of the appliance, make sure that there is

EASY ACCESS TO THE BOILER UNIONS.

EASY ACCESS TO THE DRAIN DOWN VALVE.

EASY ACCESS TO THE OIL CONNECTION.

EASY ACCESS TO THE ISOLATION VALVE.

Water can be connected to the appliance via 4 x 1 inch BSP female sockets, welded into the boiler at the rear top and bottom.

Alternative access to either side of the appliance, allows the installer to fit the appliance in either port or starboard locations.

Make sure that the vertical sides of the fireplace can easily accommodate the pipe work.

When installing water heating Bubble appliances, the space heating output will be reduced.

The boiler is high water content and suitable for pumped or gravity systems both open vented or pressurised.

If you are not suitably qualified, arrange for a heating engineer to do the design and fitting work for you. See FIG 5 for schematic layout.

CALORIFIERS. FIG 5

Indirect calorifiers must be used on gravity or pumped systems.

If you are going to install a gravity system you must make sure that you purchase a special calorifier with a 28 mm internal diameter coil, **don't be put off by suppliers who say that they have 28mm connections which are adequate, they are not as effective.**

On gravity systems the calorifiers must be located higher than the appliance and as close as possible to it, obviously keeping horizontal runs as short as possible.

VENTING OF AIR. FIG 5

Gravity or Pumped systems can be fitted with open vented or pressurised systems.

If open vented systems are used the feed and expansion tank must be as close as possible to the boiler and be fitted at the highest part of the circuit. Consult an experienced boat-heating engineer for advice on feed and expansion tanks.

To vent the system of air use automatic air vents on all possible air lock locations.

PIPE WORK. FIG 5

All gravity pipe work must rise on flow and fall on return and be a minimum of 28mm dia. (35mm dia preferred)

To reduce resistance to flow:-

- Use swept bends, do not use elbows.
- Use copper pipe work.
- Use high water content radiators.

The primary circuit must have a total length of not more than 6 meters otherwise the recovery time of the calorifier will be increased beyond an acceptable period of time.

Primary circuit pipe work must not have valves or other devices that can be used to interfere with the free flow of water.

PUMPED SYSTEMS. FIG 5

Always come off the appliance with 28mm copper for a minimum run of 350 mm before dropping on to 22mm hep 2o

To ensure suitable flow of water through the primaries a suitable injector tee should be used. Great care should be taken with the positioning of the circulating pump and the feed and expansion tank to make sure that the water flows where it should and that over pumping does not occur.

The heating circuit must be piped in 22mm copper or

Hep 2o with 15mm stabs to radiators.

Where additional radiators are fitted as heat leaks, the pipe work must be kept as short as possible, rise on feed and fall on return.

SAFETY VALVE. FIG 5

A 1" safety valve must be fitted as close to the boiler as possible (within 300mm) and the outlet from it must be directed to a safe location so as not to present any danger should the valve blow-off and exit steam or boiling water.

Note, safe location could be through the side of the boat, with a deflector to stop any horizontal emission.

WATER TREATMENT.

To reduce the build up of lime scale in the primary circuit pipe work the temperature of the water should not be allowed to exceed 65 Deg C and a suitable water treatment should be added.

If the boat is to be left unattended the water, in the heating system should also have suitable antifreeze added or be drained down.

DRAIN DOWN. FIG 5

A drain down valve should be fitted at the lowest point of the circuit.

CIRCULATING PUMP. FIG 5

On pumped systems make sure that the circulating pump is fitted in such a way as to make it easily replaceable, this means lock shielded valves at either side and easy access.

7. COMMISSIONING.

If the appliance has been fitted to an existing heating system, make sure that the system is adequately designed and complies with the details specified in this manual.

If the heating circuit does not comply, it must be modified, before attempting to light the appliance.

Commissioning takes the following form:

PRE FIRING CHECKS.

LIGHTING.

POST FIRING CHECKS AND ADJUSTMENTS.

PRE FIRING CHECKS.

FUEL SUPPLY. FIG 4

Tank, check for leaks-stability-height-position-vent. Check for leaks on the entire oil feed line from tank to appliance.

FUEL.

Check for correct grade.

FILTER. FIG 4

Is it fitted-check for function and leaks?
Oil line- check for function, positioning, material suitability and leaks.



FIRE VALVE. FIG 4
Check for function and leaks.

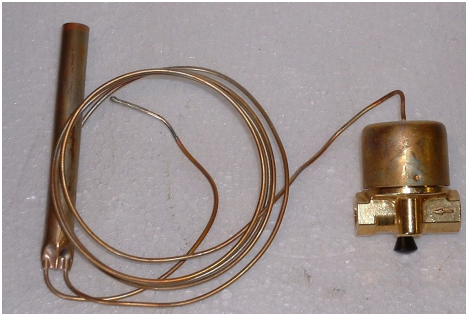

THROUGH BULKHEAD. FIG 4
Bulkhead fittings to be used.

ISOLATION VALVE. FIG4
Check for function, convenience of positioning and leaks.

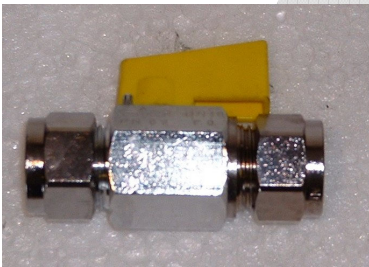

PURGING NEW OIL LINES. FIG 4
Flush at least 5 litres of oil through the line to check for contamination and to clear the oil line of installation debris and trapped air.

AIR LOCKING. FIG 4
Make sure that the oil feed supply pipe is level and has no potential for air locking. (Kinks, wavy runs, and sudden changes in level or slope).

ELECTRICAL.
Check for correct fusing, location and specification of any isolation devices.

VENTILATION.

Make sure that adequate ventilation is provided in line with boat safety scheme.

HYDRAULIC SYSTEMS. SEE FIG 5

Water systems should be pre-checked for leaks and tests must be made to make sure that water will flow freely through the boiler and that the boiler and pump is vented and free from trapped air.

Make sure that the heat leak circuit is adequate and unvalved.

CHIMNEY SYSTEM

Chimney heights must be a minimum of 1.8 meter for low fire use and 2.2 meter for high fire use.

Check the appliance is fitted with adequate clearances from combustibles.

Check that the combustion air restrictor is functioning correctly.

DISTANCES FROM COMBUSTIBLES

Make sure that both the appliance and flue system comply with the required distances from combustibles.

LIGHTING.

WARNING FOR BOILER APPLIANCES.

*If the appliance is fitted with a boiler, air locks or poor water flow through it may cause damage.
Make sure that the boiler has been vented of all air*

BEFORE ATTEMPTING TO LIGHT THE APPLIANCE.

Note; oven stoves are very efficient and as a consequence of this the flue pipe is slow to heat up. Most of the initial heat gets absorbed by the oven therefore before attempting to light the stove especially on a cold boat, it is advisable to pre heat both the burner pot and the flue pipe to make sure that the slug of cold air in the flue and appliance is rising and will allow air for combustion to be pulled into the burner pot. If the flue is not drawing air and the appliance is cold, fumes may well leak from the appliance and the ignition process can be long winded.

Lighting the appliance takes a little time and patience; the following procedure should be adopted.

Open the front door.

Remove the coal kit if it has been supplied with the appliance.

Remove the inner mesh catalyser



Turn the oil on at full rate and allow oil to flow into the bottom of the pot to form a pool about the size of a small digestive biscuit and then turn the oil off.

Do not allow any depth of oil to build up.

Light a small piece of firelighter (about the size of a pineapple chunk) and place it into the centre of the pot.

Replace the lower burning ring, the mesh catalyser and the coal kit and then leave the door slightly open whilst the firelighter gets the oil going.

If fume leaks out of the appliance this is a sign that the flue pipe is not hot enough and needs to be pre heated.

After 30 to 40 seconds, you will notice the flame start to establish itself and spread around the bottom of the pot.

When this occurs, close the door and turn the oil on to its minimum setting.

If the flame goes out or runs very sooty this is a sign that the flue is not hot enough.

After two or three minutes the flame should then slowly change from yellow into blue flame combustion and settle down to a steady burn.

Note there may be the occasional growl or audible vibration whilst the burner settles down into blue flame combustion.

Allow the burner 10 - 15 minutes to stabilise and the increase the flow of oil as required, moving by one increment of the dial only.

Do not leave the appliance unattended during the lighting and stabilising procedure.

COMMISSIONING THE HIGH AND LOW FIRE.

Adjustments should be made by reference to the oil valve booklet supplied with the appliance

Allow at least one hour for the chimney and appliance to warm up thoroughly before making any adjustments to the high or low fire screws.

When the burner has established good blue flame combustion turn it up to half output. (Setting 3 on the fuel flow control knob) and let it stabilize.

Turn the appliance down onto minimum firing rate and

let it stabilize.

After stabilization there should be a dull red glow in the catalyser with wispy blue flames flickering just over the top of it, approximately level with the top of the pot.

If the flame falls into a dirty rolling yellow flame and the catalyser is not dull red then the low fire will need to be increased until the burner can support the required blue flame combustion.

When you are happy with the low fire, set the high fire.

Turn the oil flow knob up to setting 4, let the flame stabilize, and look at it, if it is stable and blue, turn it up slowly using the control knob, letting it stabilize after each movement, *if the flame starts to go yellow with long flame combustion, it is running fuel rich and the high fire screw needs adjusting to reduce the flow of oil. (Screw the adjuster screw in to reduce the high fire oil flow.)*

Before adjusting the high fire screw, turn the flame down and let it stabilize in blue flame combustion, adjust the high fire screw by half a turn in and try turning the fuel flow up, if it is still fuel rich repeat the process until the high fire flame is running blue with flicks of yellow in the tips.

On the Socomef pot, the **high fire flame** will be set approx 40mm higher than the top of the pot.

CHECKING THE ACTION OF THE BUILT IN THERMOSTAT.

Boiler appliances have a thermostat assembly attached to the top of the oil control valve.

After the high and low fire has been set, check the action of the thermostat and overheat stat.

Do this by turning off the circulating pump and putting the appliance on to high fire.

As the boiler temperature increases the thermostat will shut the appliance down on to low fire, because the circulating pump is not working the boiler will carry on increasing temperature, at approx 80 deg C the safety stat will shut the oil valve down and the appliance will go out.

If this does not occur there could be a fault on the thermostat assembly.

8. FAULT FINDING HEATING SYSTEM.

If the system does not perform well check the following-:

THE CIRCUIT DESIGN. FIG 5

AIR LOCKED CIRCULATING PUMP. FIG 5

AIR LOCKED SYSTEM PIPEWORK. FIG 5

INADEQUATE SYSTEM PRESSURE HEAD.

INOPERATIVE CIRCULATING PUMP. FIG 5

INADEQUATE PIPE SIZING. FIG 5

INADEQUATE CALORIFYER DESIGN. FIG 5

INADEQUATE APPLIANCE LOCATION.

The appliance is fitted out of level, allowing an air pocket to build up in the top of the boiler, causing subsequent kettling and damage to thermostat sensing phial

FLOW OF WATER THROUGH THE BOILER. FIG 5

WATER THROUGH THE CALORIFYER.

FLOW OF WATER THROUGH THE RADIATORS.

THE SYSTEM IS NOT OVER PUMPING.

LACK OF PRESSURE RELEASE SAFETY VALVES.

FEED AND EXPANSION.

Is it fitted in the correct place?

9. FAULT FINDING COMBUSTION.

1. RACING.

1. Audible vibrations generated by the flame caused allowing by too much oil in the pot, too quickly.
1-1. Turn off the oil flow until the burner has settled down to a steady burn rate and then turn the fuel on again but don't let the flame go out otherwise the burner **MUST** be allowed to cool down fully before a re ignition is attempted.

2. FLUE VACUUM.

1. The pot type burner is extremely sensitive to flue vacuum variations.
2. Good combustion will not be possible unless our instructions on chimneys and flue vacuum are followed. See fig1
3. If the burner does not burn with a blue flame, recheck the chimney vacuum and oil flow rate.
4. If the burner does not run well check that the seals in the appliance are good and that there is no ingress of air into the appliance flue ways.
5. Check that the correct fuel oil is being used.
6. Check the levels.

3. BURNER RUNS SOOTY.

Comments made on this subject assume that the appliance has been running normally for some time. If the appliance soot's up this indicates that there is not adequate air for blue flame combustion or there is an excess of fuel.

Check that the chimney is working correctly. (This means pulling enough air into the burner to allow correct blue flame combustion to occur.

Check that the fuel is the correct type and quality. Check that the flow rates are correct.

Where burners are run at high fuel flow rates on low chimney vacuums, long unsatisfactory yellow flame combustion and bad sooting will occur.

To rectify this problem reduce the high fire flow rate screw on the Oil Control Valve until blue flame combustion occurs.

Never switch from low settings to high settings; a longer burner life will be achieved if the regulator is moved only by one number at a time leaving approx. one minute between each setting change.

4. BURNER DOES NOT LIGHT EASILY.

Read the instructions in the lighting section of this publication.

5. OIL WILL NOT ENTER THE POT.

Is there oil in the fuel tank?

Has the fire valve tripped?

Has the isolation valve been accidentally turned off?

Is the oil turned on at the oil flow control knob on the valve?

Is the oil feed pipe from the valve to the pot?

Blocked. (Unlikely)

Has the water stat tripped off on the aqua stat?

Has the aqua-stat been damaged by overheating.

To check this out, remove the aqua-stat from the valve and remove the phial from the boiler, re cock the valve and test fire the appliance. See Fig 4 Toby Valve document.

Note this type of damage is not covered by the warranty.

6. OIL SMELLS.

Visual check on all joints for obvious leaks.

Check that the descaling lever packing gland nut is adjusted.

7. DEFLOODING A FLOODED POT.

To carry out this procedure you will need -:

- a. A small leak proof plastic bag.
- b. A small sponge.
- c. A larger plastic bag for disposal of the residue.
- d. A pair of disposable plastic gloves.

If the pot becomes flooded, de flood it is as follows -:
Put a small plastic bag into the appliance and sponge from the pot into the bag, when the excess oil has been removed put the plastic bag and sponge into another plastic bag and dispose of it.

8. OPERATING OIL FLOW RATES.

OIL Flow rates in cc per minute.

Min	Max
4cc	10cc

Oil Flow Rates In litres per hour.

.24 litres	.6 litres
------------	-----------

Oil Flow Rates In litres per 24 hours.

5.76 litres	14.4 litres
-------------	-------------

Oil Flow Rates In litres per 7 x 24 hours.

40.32 litres	100.8 litres
--------------	--------------

10. ROUTINE MAINTENANCE.

Continuous running assumed.

1. EVERY 4 WEEKS-:

Operate the descaling lever by turning it completely two or three times.

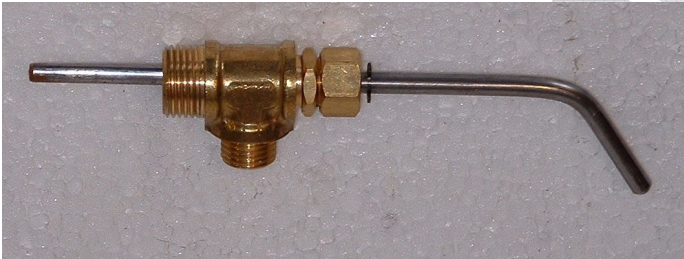

2. AS REQUIRED -:

Clean inside of door glass.

3. EVERY EIGHT WEEKS -:

Clean the burner completely by removing all the inner components as follows,

1. Open the front door.
 2. Remove the coal kit if it has been supplied with the appliance.
 3. Remove the inner mesh catalyser.
 4. Remove the lower burning ring.
- Scrape the bottom of the pot and remove all carbon build up.
Reassemble in the reverse order.

Corner appliance pot.



Section through corner appliance pot minus catalyser.

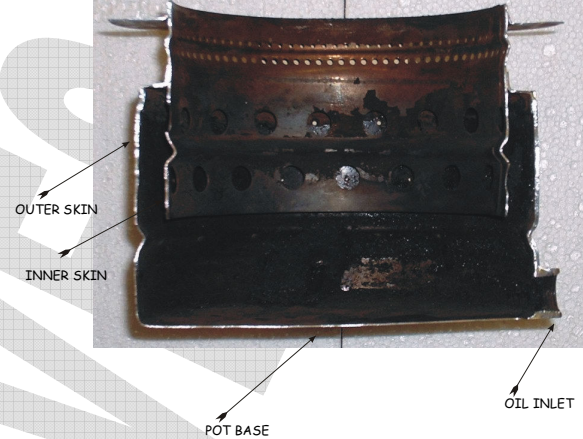

4. EVERY 24 WEEKS-:

4-1. Tighten up the compression nut on the descaling device to stop oil smells.

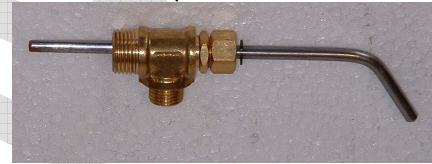

4-2. Section through descaling device.

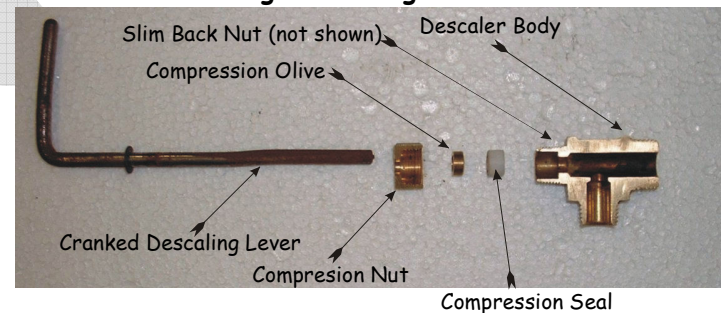

5. ONCE PER YEAR-:

Have your service man replace or clean all the filters in the oil supply line.

6. EVERY TWO YEARS -:

Have your service man clean the filter in the Oil Control Valve and check the function of all the safety equipment associated with the appliance, oil supply and plumbing system.

Remove and clean out the oil supply pipe from the valve to the pot.

7. AS REQUIRED -:

Keep the Coals, Coal kit, and burner inners in good condition, replace as necessary.

11. WARRANTY.

You are advised that if Harworth Heating Ltd is called out to appliances under warranty claims, where no

appliance fault can be found, charges will be made at the rate of £125.00 per hour, including travelling time.

Fill in the warranty form and returned it to us, the information recorded on the warranty form helps us to deal with any problems you may encounter.

Where we do not hold returned warranty forms replacement parts would only be issued when we are sure that the appliance has not been damaged by improper use or installation.

The warranty covers PARTS ONLY for a period of ONE YEAR and is conditional upon all the requirements

of our installation instructions being fully adhered to.

12. WARRANTY ITEMS NOT COVERED.

DOOR GLASS.

LABOUR COSTS.

TRAVELING COSTS.

CONSEQUENTIAL LOSS.

CONSEQUENTIAL DAMAGE.

14. APPLIANCE Distances from Combustibles

Appliance Type	ABOVE	BELOW	SIDES.	BACK	FRONT	HEARTH
BOAT B1	400	25	300	150 FROM HEAT SHIELD	400	25 THICK X 150
BOAT B2	400	25	300	150 FROM HEAT SHIELD	400	25 THICK X 150
BELFORT	400	25	300	150 FROM HEAT SHIELD	400	25 THICK X 150
CORNER	200	25	200	25 FROM HEAT SHIELD	300	25 THICK X 150
CORNER OVEN	150	15	200	25 FROM HEAT SHIELD	300	15THICK

ROUND	200	ALLOW 300 ALL AROUND THE APPLIANCE	25MM THICK HEARTH
-------	-----	------------------------------------	-------------------

Protection can be gained by the use of -:

- Sheet metal heat shields and spacers.
- Heat resistant boards.

Combustible materials can be-:

- Wooden furniture.
- Curtains.
- Wooden panels or frames adjacent to the flue pipe or where it passes through the deck of the boat.
- Carpet or flooring close to the appliance.
- Items near to the appliance, which could fall onto it and ignite, should the boat suffer a slight impact.

15. Flue Pipe Distances from Combustibles

For all appliances-:

150 for single skin pipes.

25 mm for insulated flue pipes.

16. Oil Supply Layout

FIG 4

CORNER STOVE OIL LAYOUT ISS 2

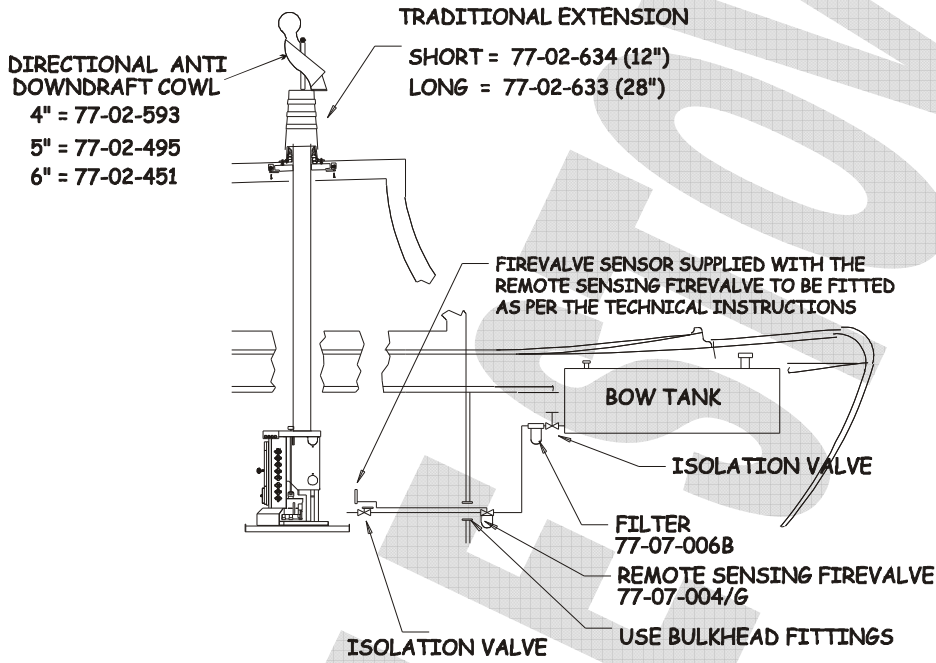

COPYRIGHT HARWORTH HEATING LTD 080800

17. Plumbing Layout Options

Each of the stoves has a different output to water and the installing engineer should first of all establish the boiler output to water and then design the heat losses accordingly.

Note that some of the boilers can only provide heat for a calorifier and towel rail.

FIG5

SCHMATIC GRAVITY SYSTEM ISS1 OF 08-07-01
READ IN CONJUNCTION WITH TECHNICAL INSTALLATION MANUAL

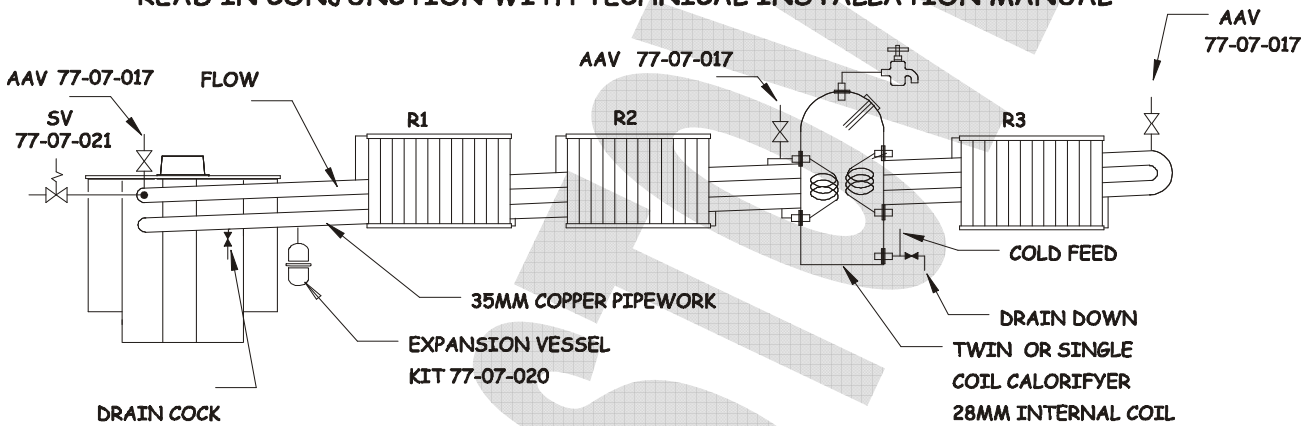

SCHMATIC PUMPED SYSTEM ISS1 OF 08-07-01

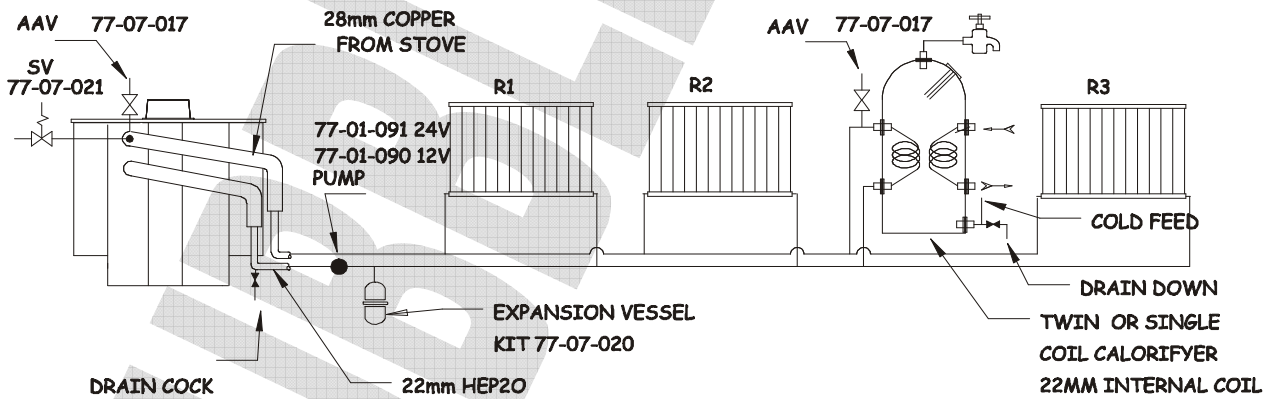

© HARWORTH HEATING LTD 30.6.98

This publication may not be copied by any means, without written permission from the authors.

This product is subject to continuous development and improvement and it is consequently acknowledged that due to this process there may be some omissions and errors.

This publication is intended only to assist the reader in the use of this product and therefore Harworth Heating Ltd shall not be liable for any loss or damage whatsoever arising from the use of any information, error or omission found in this guide.

Only approved personnel, WHO HAVE BEEN SUITABLY TRAINED, must carry out maintenance on this product.



CORNER OVEN OIL APPLIANCE

INSTALLER INSTRUCTIONS ISSUE 1 - 05-02-17

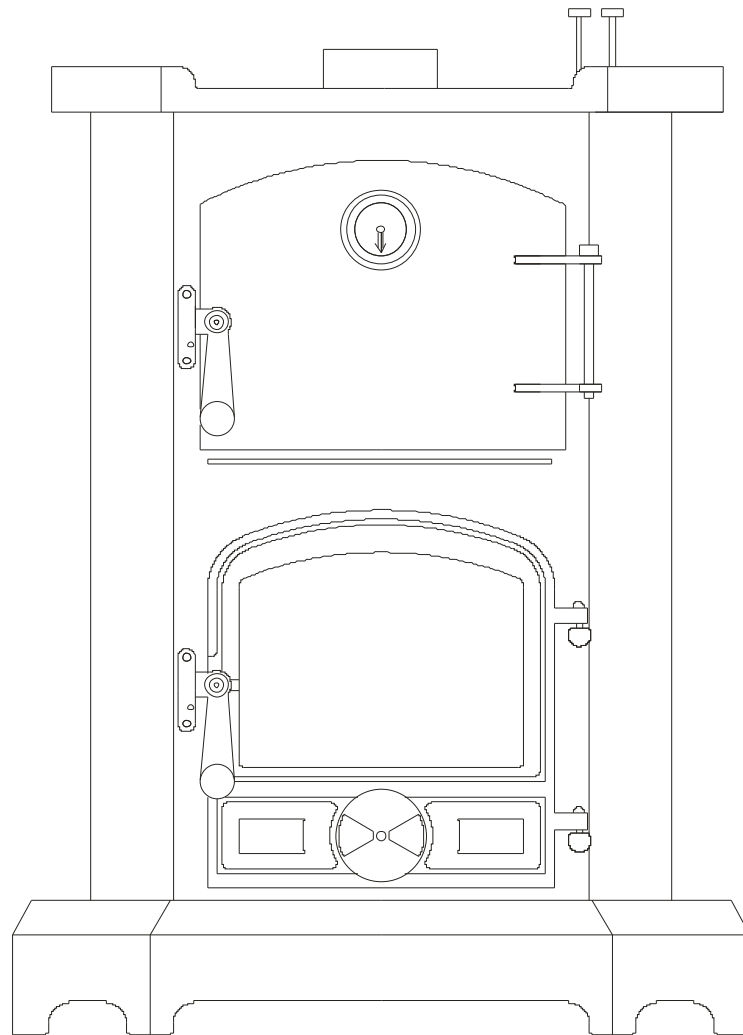

www.harworthheating.co.uk

INDEX

1. BEFORE STARTING THE JOB.	5
ABOUT THE APPLIANCE.....	5
CONTROLS.....	6
2. SAFETY.	6
FUMES.....	6
FIRE.....	6
BURNS.....	7
CLEARANCES FROM COMBUSTIBLES (APPLIANCE).....	7
CLEARANCES FROM COMBUSTIBLES (FLUE).....	7
VENTILATION.....	7
IMPACT RESISTANCE.....	7
3. CHIMNEY.	7
THE HEIGHT.....	7
THE DIAMETER.....	7
THE TEMPERATURE OF THE GASSES IN IT.....	7
THE RESISTANCE OF THE INNER SURFACE OF.....	7
THE FLUE PIPE OR PIPES.....	7
THE CHIMNEY RULES.....	7
4. FUEL SUPPLY. SEE FIG 4	8
WAXING.....	8
TRIM.....	8
TANK. SEE FIG 4.....	8
OIL LINE. SEE FIG 4.....	8
WATER CONTAMINATION.....	8
REMOTE SENSING FIREVALVE. FIG 4.....	8
ISOLATION VALVES. FIG 4.....	8
SLEEVING. FIG 4.....	9
5. FIREPLACE.	9
THE HEARTH.....	9
FIREPROOFING.....	9
APPLIANCE FEATURES.....	9
FASTENING DOWN.....	9
6. FITTING DRY APPLIANCES.	9
SELECT LOCATION.....	9
FIT OIL TANK. FIG 4.....	9
RUN OIL LINE. FIG 4.....	9
TRIAL FIREPLACE ASSEMBLY.....	9
TRY APPLIANCE IN POSTION.....	9
ESTABLISH FLUE POSITION.....	9
MARK AND CUT ROOF PLATE.....	9
FIT DECK FLANGE.....	9
FIT FIRESTOP SPACER.....	9
FIT CEILING PLATE.....	9
TRIAL FIT FIRE.....	9
TRIAL FIT EVERYTHING ELSE.....	9
IF IT ALL FITS REFIT IT PERMANENTLY.....	9
SELECT LOCATION.....	9
FIT OIL TANK. FIG 4.....	9

RUN OIL LINE. FIG 4	9
TRIAL FIREPLACE ASSEMBLY.....	9
TRY APPLIANCE IN POSITION.....	9
ESTABLISH FLUE POSITION.....	9
MARK OUT AND CUT THE ROOF PLATE.....	10
FIT DECK FLANGE.....	10
FIT FIRESTOP SPACER.....	10
FIT CEILING PLATE.....	10
ABOVE DECK EXTENSION.....	10
6. FITTING WET APPLIANCES.....	10
EASY ACCESS TO THE BOILER UNIONS.....	10
EASY ACCESS TO THE DRAIN DOWN VALVE.....	10
EASY ACCESS TO THE OIL CONNECTION.....	10
EASY ACCESS TO THE ISOLATION VALVE.....	10
CALORIFIERS. FIG 5	11
VENTING OF AIR. FIG 5	11
PUMPED SYSTEMS. FIG 5	11
SAFETY VALVE. FIG 5	11
WATER TREATMENT.....	11
DRAIN DOWN. FIG 5.....	11
CIRCULATING PUMP. FIG 5.....	11
7. COMMISSIONING.....	11
PRE FIRING CHECKS.....	11
FUEL SUPPLY. FIG 4	11
FUEL.....	11
FILTER. FIG 4.....	11
FIRE VALVE. FIG 4	12
THROUGH BULKHEAD. FIG 4	12
ISOLATION VALVE. FIG4.....	12
PURGING NEW OIL LINES. FIG 4	12
AIR LOCKING. FIG 4	12
ELECTRICAL.....	12
VENTILATION.....	12
HYDRAULIC SYSTEMS. SEE FIG 5.....	12
CHIMNEY SYSTEM.....	12
DISTANCES FROM COMBUSTIBLES.....	12
LIGHTING.....	12
BEFORE ATTEMPTING TO LIGHT THE APPLIANCE.....	12
COMMISSIONING THE HIGH AND LOW FIRE.....	13
CHECKING THE ACTION OF THE BUILT IN THERMOSTAT.....	13
8. FAULT FINDING HEATING SYSTEM.....	13
THE CIRCUIT DESIGN. FIG 5.....	13
AIR LOCKED CIRCULATING PUMP. FIG 5.....	13
AIR LOCKED SYSTEM PIPEWORK. FIG 5.....	14
INADEQUATE SYSTEM PRESSURE HEAD.....	14
INOPERATIVE CIRCULATING PUMP. FIG 5	14
INADEQUATE PIPE SIZEING. FIG 5.....	14
INADEQUATE CALORIFYER DESIGN. FIG 5	14
INADEQUATE APPLIANCE LOCATION.....	14
FLOW OF WATER THROUGH THE BOILER. FIG 5.....	14
WATER THROUGH THE CALORIFYER.....	14

FLOW OF WATER THROUGH THE RADIATORS.....	14
THE SYSTEM IS NOT OVER PUMPING.....	14
LACK OF PRESSURE RELEASE SAFETY VALVES.....	14
FEED AND EXPANSION.....	14
9. FAULT FINDING COMBUSTION.....	14
1. RACING.....	14
2. FLUE VACUUM.....	14
3. BURNER RUNS SOOTY.....	14
4. BURNER DOES NOT LIGHT EASILY.....	14
5. OIL WILL NOT ENTER THE POT.....	14
6. OIL SMELLS.....	14
7. DEFLOODING A FLOODED POT.....	14
8. OPERATING OIL FLOW RATES.....	14
10. ROUTINE MAINTENANCE.....	15
1. EVERY 4 WEEKS-:.....	15
2. AS REQUIRED -:.....	15
3. EVERY EIGHT WEEKS -:.....	15
4. EVERY 24 WEEKS-:.....	15
5. ONCE PER YEAR-:.....	15
6. EVERY TWO YEARS -:.....	15
7. AS REQUIRED -:.....	15
11. WARRANTY.....	15
12. WARRANTY ITEMS NOT COVERED.....	16
DOOR GLASS.....	16
LABOUR COSTS.....	16
TRAVELING COSTS.....	16
CONSEQUENTIAL LOSS.....	16
CONSEQUENTIAL DAMAGE.....	16
14. APPLIANCE DISTANCES FROM COMBUSTIBLES.....	16
15. FLUE PIPE DISTANCES FROM COMBUSTIBLES.....	16
16. OIL SUPPLY LAYOUT.....	17
17. PLUMBING LAYOUT OPTIONS.....	18

Read in conjunction with the appropriate:-

1. Oil control valve leaflet.

If you have any difficulties please phone our technical help line on:-

01302 742520 fax 01302 750573

e mail sales@oilappliances.co.uk.

www.oilappliances.co.uk

1. BEFORE STARTING THE JOB.

ABOUT THE APPLIANCE.

The corner oven appliance is a simple development of the corner oil appliance incorporating a small oven built directly on top of a corner oil appliance.

It is installed in the same way as the corner oil.

There are a few changes which are incorporated as follows:-

1. The drip tray has an adjustable plate mounted to it which can be used for levelling purposes.

Drip Tray and Adjuster Plate



Adjuster Plate Locking Fasteners



2. For maintenance purposes the oil control valve has been mounted on a removable plate which allows the valve to be removed from the appliance should the need arise.

To remove the valve, first remove the left and right hand side panels, then remove the oil feed pipe by

disconnecting at the descaling device and then undo the straight compression joint and then remove the oil feed pipe from the valve.

Undo the single locking screw, disconnect the oil flow control rod and the thermostat control rod from the oil control valve and the valve and plate should then slide out.

Removable valve mounting plate.



As per the Corner Oil stove, standard deck flanges and traditional chimney extensions can be used above deck but we do recommend the use of an anti downdraft terminal.

As per the Corner Oil stove the appliance will provide space or combined space and water heating plus cooking on dry models and limited cooking on boiler models.

There are two versions of the appliance, dry and wet. The dry version is designed for space heating and cooking.

The wet version is designed for space and water with limited cooking.

On the wet, boiler version, there are 4 x 1" BSP female sockets for connections to be made to the heating circuits as required at either side of the appliance.

The boiler is high water content and suitable for pumped or gravity systems, pressurised or open vented, provided that they are correctly designed.

OPERATING PRINCIPLES.

The appliance is designed as a continuous running space heater, which burns vaporized diesel fume in a controlled manner utilizing a chimney to discharge the products of combustion and a pumped or gravity fed oil supply.

Once ignition has occurred oil goes into the pot where

it is vaporised and burned at a steady and controlled rate via gravity flow, metered by the OIL CONTROL VALVE.

The oil flow can be controlled from minimum to maximum or any setting in between determined by where you set the oil flow control knob.

Air for combustion

is drawn into the vaporizing pot by the natural action of the negative pressure in the chimney and to allow the chimney to work correctly it is essential that there is adequate, unrestricted ventilation into the area where the appliance is situated and the flue system is warm enough to pull air through the burner in the appliance.

The amount of vapour that can be successfully burned is directly proportional to the amount of air that the chimney can draw into the pot and so to achieve adequate combustion a balanced and appropriate flow of both oil vapour and air is required.

CONTROLS.

The output of the appliance is regulated by the amount of oil for vaporization which is allowed to go into it and this function is controlled by the -:

OIL CONTROL VALVE (O.C.V.), which is situated at the right hand side of the appliance, behind the right hand side panel.

Turning the knob anti clockwise controls the oil flow. The knob is located at the top right hand side of the appliance and is calibrated from off position (fully clockwise) through 6 graduations to maximum.

Controls for the appliance will vary, depending on which valve is fitted to it.

The valve could be an OCI ships valve or a Toby valve and this should be specified with the order for the appliance.

The control for the dry appliance comprises-:

1. Oil flow control only.

The boiler version has extra controls which are-:

1. Oil flow control
2. Thermostat control
3. Safety Stat reset control

The Toby oil control valve only is used on boiler appliances. This valve has a built in, non electric, modulating thermostat control, which will put the fire on to low fire when the target temperature has been achieved.

In addition to this there is also a similar safety stat, which will shut the burner down, should the water exceed 80 deg C.

The safety stat re set control is lifted to reset the

valve, should the stat trip.

The Toby valve has to be tripped into action by lifting the trip button at the left hand side of the control panel.

The flow of oil into the pot can be adjusted via the knob on top of extension rod rising up from the oil control valve.

With the increased flow of oil, extra heat is generated, which in turn stimulates the chimney to work harder and consequently draw more air into the pot to maintain an adequate fuel air ratio.

2. SAFETY.

Take care to make sure that safety and ventilation issues are adequately addressed.

FUMES

When the appliance is first ignited, it may be necessary to warm the chimney and the base of the pot with a propane gun; this will get the cold air moving in the stack and allow the burner to draw in.

Under non starting cold chimney situations, here are the main causes of fume or smoke to leak from the appliance.

- The chimney is blocked.
- There are too many bends in the chimney.
- The above deck chimney extension is not high enough.
- The boat is moored in a position near to high buildings or trees and downdraughting is occurring.
- The chimney is not airtight.

FIRE.

Fire can be caused by a variety of potential danger points and because of the space limitation on boats; this risk is ever present and must be adequately assessed.

The main danger is the effects of heat from the appliance on combustible materials and boat occupants. Make sure that all combustibles are adequately protected from the effects of heat radiation.

The appliance must stand on a fireproof base as per the distance from combustibles table.

On appliances using the coal kit, the floor in front of the appliance must have suitable fire protection extending a minimum of 100mm in front of the appliance.

The appliance has built in rear heat shields and when the appliance is positioned in a suitable location there must be a space of 25mm clearance beyond the outer heat shield, to allow air to rise up and around the heat shields.

The rear of the upper oven is insulated and the insulation is covered by a metal heat shield type plate. **Do not remove the heat shields under any circumstances.**

BURNS.

During normal, day-to-day use, many parts of this appliance, pipe work, and chimney can become too hot to touch.

Where necessary, we recommend that suitable guards be fitted, to provide adequate protection from the heat generated by the appliance. Fireguards must comply with BS6539.

Always use heatproof gloves when working on or near to a hot appliance.

CLEARANCES FROM COMBUSTIBLES (APPLIANCE)

See table in 14.

CLEARANCES FROM COMBUSTIBLES (FLUE)

See table in 14.

VENTILATION.

Ventilation plays a vital role in the fitting and sighting of any appliance.

The provision of ventilation for this appliance is adequately covered by the requirements of the boat safety scheme.

25-cmsq. Minimum permanent ventilation, directly to outside air, must be provided for this appliance.

WARNINGS.

Never try to relight a hot appliance; wait until it has cooled down.

Hot oil vapour is explosive.

Never try to light a flooded pot.

When attempting to light an appliance, make sure that the pot is not flooded with oil by looking into the base of the burner.

If it is flooded remove the excess oil as per instructions in the faultfinding section.

The appliance must be securely fastened down so that it can resist impact or collision and it must be level in both directions.

The appliance must not be operated with the glass front door opened or cracked, or without the lighting port plug fitted.

Only Qualified persons can install unvented plumbing systems.

A suitable and serviceable fire extinguisher should always be readily accessible.

IMPACT RESISTANCE.

The appliance must be securely bolted down so that it can resist impact or collision and it must be level in both directions.

Two fixing brackets are provided; these should be fitted over the oil drip tray up stand and fastened down through the hole provided.

3. CHIMNEY.

The power, (*suck or vacuum the chimney can develop*) depends upon the following:-

THE HEIGHT.

THE DIAMETER.

THE TEMPERATURE OF THE GASSES IN IT.

THE RESISTANCE OF THE INNER SURFACE OF

THE FLUE PIPE OR PIPES.

It is obvious that on a boat all the above elements are in short supply.

Normally, we have low flues which are small in diameter and generally not very well insulated, coupled with all these problems we have an additional one, which is that the boat moves across constantly changing surroundings, through locks, into headwinds and crosswinds, all creating major opportunity for down draughting to occur.

Any bend in any part of the chimney or roughness on the internal chimney wall will slow down the velocity of rising gases and reduce the effectiveness of the chimney.

Any slight reduction in the flue gas temperature will reduce the chimney vacuum or pull, hence when the appliance is slowed down for all night burning, as the flue gas cools down the chimney vacuum reduces and as the chimney vacuum drops, the appliance may well start to burn sooty. This problem is highlighted even more during very cold weather when the chimney can cool down even faster.

THE CHIMNEY RULES.

1. Always use a top outlet for flue pipe take off.
2. Never put any sharp bends in the flue. (*To maintain a concentric fit, we will allow a slight kick off the appliance and a similar kick into the deck flange*).
3. Always try to get the appliance as low as possible in the boat, this will allow installation of maximum length flue pipe.
4. Always have two double walled, above deck extensions, short for cruising and long (28inch minimum) for mooring. Insulated extensions are a thing of the future but it is possible to fill the space using a vermiculite and cement mix sealed off with flexible fire putty or heat proof silicone.

5. Fit a rotary swinging cowl to each extension or make one interchangeable.
6. Clean or have the chimney cleaned regularly. (Frequency depends upon type of fuel and length of time used).
7. Flue pipes should leave the appliance vertically and go through the roof of the vessel vertically.
8. **Under no circumstances should straight flue pipes be wedged in to the stove flue collar at an any angle less than vertical.**

4. FUEL SUPPLY. SEE FIG 4

There are several problems relating to diesel fuel supply, which need be adequately addressed.

WAXING.

Cold weather waxing or thickening alters the flow characteristics of diesel.

An adequate fuel feed supply can turn into an inadequate one when the temperature starts to fall. The worst scenario is fuel feed pipe 50-60 feet long in 8mm dia pipe.

The best-case scenario is a fuel pipe 4 feet long in 10mm dia with insulated lagging.

TRIM.

A minimum pressure head of out 8" is required.

This head is measured from the base of the oil tank to the top of the oil control valve. In some cases this head can be affected by the ballast or trim of the boat.

Take great care to try out all the different ballast and trim possibilities to make sure that adequate oil feed is always available at the outlet end of the fuel pipe before it enters the oil control valve at the appliance.

TANK. SEE FIG 4

If the appliance is fitted at the bow of the boat, a bow tank is recommended.

The tank should comply with the requirements of the boat safety scheme and have:-

- A conveniently sized filler
- A means of venting.
- A conveniently located, easily visible, contents gauge.
- An isolation valve
- An easily replaceable cartridge filter.

Do not use glass filter bowls, they are not acceptable under the boat safety scheme.

Always add a suitable proprietary antifreeze additive

to the appliance fuel for wintertime running.

OIL LINE. SEE FIG 4

The oil feed line starts after the fuel filter and proceeds to the point of entry, which is where the oil line goes into the cab or saloon of the boat.

Where oil lines go through bulkheads, use correct bulkhead fittings.

The diameter of the oil line is dependant upon the length of run.

At this point it is necessary to fit a remote sensing fire valve, designed to shut off the oil supply, should a fire occur near to the appliance.

If the bubble appliance is fitted up to the first bulkhead it will be necessary to fit the isolation valve outside the cabin or saloon of the boat.

WATER CONTAMINATION.

Because of the high risk of fuel contamination with water, we strongly recommend the fitting of a high volume water trap in the oil supply line.

REMOTE SENSING FIREVALVE. FIG 4

The fire valve has a capillary tube on the end of which is a temperature sensitive phial, run the capillary tube with the oil line up to the appliance and carefully fit the sensing phial 15mm pipe clips in front of the drip tray on the fireplace hearth, directly in front of the combustion air restrictor.

Before it is fitted try the fender on the appliance to make sure that the fender does not foul the sensing phial.

The sensing phial may be visible through the bottom of the fender, to mask it, paint it with matt black paint available from our sales desk.

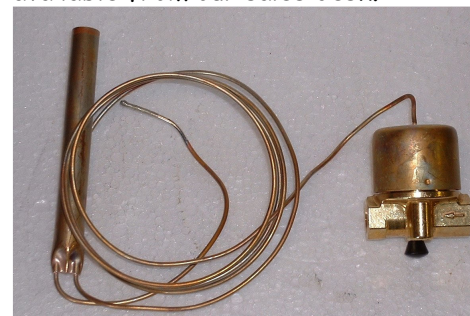

When fitting the fire valve make sure that where the capillary and oil line go through the bulkhead in separate sleeved tubes, so that the capillary can be withdrawn separately should it ever need replacing.

For fitting of long oil feed lines which pass through bulkheads and various other parts of the boat it may well be necessary to fit more than one fire valve, especially where the oil line passes through an area where a fire could occur i.e. kitchen area etc.

ISOLATION VALVES. FIG 4

Two isolation valves are required, one fitted directly into the oil control valve to allow you or the service man to turn the oil off should the need arise, and one on the oil tank fitted before the filter.

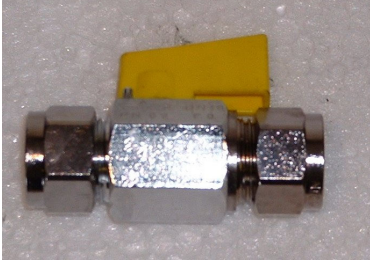

SLEEVING. FIG 4

Where the oil line goes through panels, a suitable sleeve must be fitted and sealed with a suitable sealant.

5. FIREPLACE.

Try to use materials, which are easy to keep clean and fireproof such as tiles, asbestolux, TAC board or vermiculite boarding.

THE HEARTH.

The hearth must be:-

FLAT - SECURE - FIREPROOF AND LEVEL IN BOTH DIRECTIONS.

See (Distance from combustibles.)

FIREPROOFING.

The vertical walls of the fireplace must be fireproofed, suitable materials would be tiles, asbestolux sheet, compressed vermiculite board.

APPLIANCE FEATURES.

The appliance has a base plate, which is designed to do two jobs,

- It acts as a drip tray to catch any oil spill.
- It acts as a spacer to set the appliance at a suitable distance from the vertical walls of the fireplace to allow adequate cooling air to flow around the oil valve.

FASTENING DOWN.

It is important to fix the base tray down to the hearth but don't drill through it as this will allow oil to leak from it should a spill occur. Clips to go over the top of the up stand are provided for this job.

6. FITTING DRY APPLIANCES.

SELECT LOCATION.

FIT OIL TANK. FIG 4

RUN OIL LINE. FIG 4

TRIAL FIREPLACE ASSEMBLY.

TRY APPLIANCE IN POSITION.

ESTABLISH FLUE POSITION.

MARK AND CUT ROOF PLATE.

FIT DECK FLANGE.

FIT FIRESTOP SPACER.

FIT CEILING PLATE.

TRIAL FIT FIRE.

TRIAL FIT EVERYTHING ELSE.

IF IT ALL FITS REFIT IT PERMANENTLY.

SELECT LOCATION.

The appliance can be located in any suitable corner. It and the flue system must be securely fastened, so as to withstand the normal day-to-day situations, which will be encountered in a narrow boat.

These could be:-

- Impact by other vessel.
- Impact into lock gate.
- The pitching and rolling effects of inland water sailing.
- Etc.

There are two angle brackets provided with the appliance, which hook over the front lip of the base tray and are screwed down to the hearth.

The location must have adequate protection from the effects of radiated and conducted heat as specified in section 4 and FIG1.

FIT OIL TANK. Fig 4

The oil tank will be fitted in the bow area and must comply with the requirements of the boat safety scheme. See schematic FIG 4.

RUN OIL LINE. FIG 4

Run the oil line and fit all the required components as described in sec 4 and shown in FIG 4.

TRIAL FIREPLACE ASSEMBLY.

The oil line and the fire valve sensor will have to pass through the fireplace, make sure that you make adequate provision for this and the remote sensing fire valve.

TRY APPLIANCE IN POSITION.

Try the appliance in position and make sure that the oil feed and remote sensing fire valve fit as required.

ESTABLISH FLUE POSITION.

Normally the appliance will be fitted in a corner, in a suitable fireplace; this will predict the angle at which

the flue pipe will have to be fitted.

The flue pipe will normally run at a slight angle to allow it to terminate through the ceiling, in a suitable position.

It is important to make sure that the flue fits concentrically at both the appliance end and as it passes through the fire stop spacer and deck flange. To achieve this the pipe will have to be marked out, notched and re-welded. Make a template to work from. When final fitting of the flue pipe occurs, make sure that the decorative top frame is fitted to the appliance, before the final fixing.

MARK OUT AND CUT THE ROOF PLATE.

FIT DECK FLANGE.

If you are going to use a standard deck flange for 6-inch extensions you will have to cut off the lower extension with a grinder to allow fitting of the fire stop spacer.

The deck flange will be bolted to the roof plate with a seal of silicone rubber applied between the joint.

The flue pipe provided with the appliance will be marked and trimmed off 10mm below the top of the deck flange to allow the flexible fire-cement to be flounced into a suitable taper.

The glass fibre rope will be wrapped around the flue pipe and gently pressed down on to the fire stop spacer, allow 10mm at the top of the joint and pack the gap with the flexible fire cement which will form a seal.

The deck flange will form the base for the traditional chimney extension to be fitted.

FIT FIRESTOP SPACER.

The fire stop space will be fitted in between the deck flange and the ceiling plate concentric to the flue access hole cut in the roof plate of the boat.

It will provide heat protection for any combustible materials located near to the through roof location.

The centre hole is cut deliberately undersize to accommodate differing flue sizes and angles.

It will be necessary to open up the centre hole to fit the flue pipe; this can be done by using the flue pipe as a template and carefully marking round it.

File the excess material away with a rough rasp. (Do this a little at a time to make sure that a good fit is achieved.)

The top surface of the spacer may also need trimming to provide a snug fit up to the inner surface of the roof steelwork.

FIT CEILING PLATE.

The ceiling plate will be fitted inside the boat to finish

off the through roof fitting of the flue pipe.

It will be screwed up to the trimming timber via 4 countersunk wood screws.

ABOVE DECK EXTENSION.

A traditional above deck extension can be fitted in line with normal practice.

We recommend that a short extension is used for cruising and a min 28" extension is used when mooring.

In each case we recommend the use of a rotating cowl to minimise the effects of down draught.

Fit the side panels 1 x left and 1 x right hand sides.

Fit the front fender.

6. FITTING WET APPLIANCES.

Installation of the wet appliance will be the same as the dry except that when dealing with the location an extra element comes in to the equation and that is connecting the appliance up to the heating circuit.

The appliance has a fully integral, powerful boiler, which forms the outer sides of the triangular shape and can be fitted to open vented or pressurised systems.

When connecting appliances to pressurised systems make sure that the Toby oil control valve and matching aqua stat are fitted.

Before designing the fireplace, take great care about making provision for the boiler connections and remember that the whole essence of the Corner Bubble is to make the finished job look like a piece of integrated design.

To facilitate removal of the appliance, make sure that there is

EASY ACCESS TO THE BOILER UNIONS.

EASY ACCESS TO THE DRAIN DOWN VALVE.

EASY ACCESS TO THE OIL CONNECTION.

EASY ACCESS TO THE ISOLATION VALVE.

Water can be connected to the appliance via 4 x 1 inch BSP female sockets, welded into the boiler at the rear top and bottom.

Alternative access to either side of the appliance, allows the installer to fit the appliance in either port or starboard locations.

Make sure that the vertical sides of the fireplace can easily accommodate the pipe work.

When installing water heating Bubble appliances, the space heating output will be reduced.

The boiler is high water content and suitable for pumped or gravity systems both open vented or pressurised.

If you are not suitably qualified, arrange for a heating engineer to do the design and fitting work for you. See FIG 5 for schematic layout.

CALORIFIERS. FIG 5

Indirect calorifiers must be used on gravity or pumped systems.

If you are going to install a gravity system you must make sure that you purchase a special calorifier with a 28 mm internal diameter coil, **don't be put off by suppliers who say that they have 28mm connections which are adequate, they are not as effective.**

On gravity systems the calorifiers must be located higher than the appliance and as close as possible to it, obviously keeping horizontal runs as short as possible.

VENTING OF AIR. FIG 5

Gravity or Pumped systems can be fitted with open vented or pressurised systems.

If open vented systems are used the feed and expansion tank must be as close as possible to the boiler and be fitted at the highest part of the circuit. Consult an experienced boat-heating engineer for advice on feed and expansion tanks.

To vent the system of air use automatic air vents on all possible air lock locations.

PIPE WORK. FIG 5

All gravity pipe work must rise on flow and fall on return and be a minimum of 28mm dia. (35mm dia preferred)

To reduce resistance to flow:-

- Use swept bends, do not use elbows.
- Use copper pipe work.
- Use high water content radiators.

The primary circuit must have a total length of not more than 6 meters otherwise the recovery time of the calorifier will be increased beyond an acceptable period of time.

Primary circuit pipe work must not have valves or other devices that can be used to interfere with the free flow of water.

PUMPED SYSTEMS. FIG 5

Always come off the appliance with 28mm copper for a minimum run of 350 mm before dropping on to 22mm hep 2o

To ensure suitable flow of water through the primaries a suitable injector tee should be used. Great care should be taken with the positioning of the circulating pump and the feed and expansion tank to make sure that the water flows where it should and that over pumping does not occur.

The heating circuit must be piped in 22mm copper or

Hep 2o with 15mm stabs to radiators.

Where additional radiators are fitted as heat leaks, the pipe work must be kept as short as possible, rise on feed and fall on return.

SAFETY VALVE. FIG 5

A 1" safety valve must be fitted as close to the boiler as possible (within 300mm) and the outlet from it must be directed to a safe location so as not to present any danger should the valve blow-off and exit steam or boiling water.

Note, safe location could be through the side of the boat, with a deflector to stop any horizontal emission.

WATER TREATMENT.

To reduce the build up of lime scale in the primary circuit pipe work the temperature of the water should not be allowed to exceed 65 Deg C and a suitable water treatment should be added.

If the boat is to be left unattended the water, in the heating system should also have suitable antifreeze added or be drained down.

DRAIN DOWN. FIG 5

A drain down valve should be fitted at the lowest point of the circuit.

CIRCULATING PUMP. FIG 5

On pumped systems make sure that the circulating pump is fitted in such a way as to make it easily replaceable, this means lock shielded valves at either side and easy access.

7. COMMISSIONING.

If the appliance has been fitted to an existing heating system, make sure that the system is adequately designed and complies with the details specified in this manual.

If the heating circuit does not comply, it must be modified, before attempting to light the appliance.

Commissioning takes the following form:

PRE FIRING CHECKS.

LIGHTING.

POST FIRING CHECKS AND ADJUSTMENTS.

PRE FIRING CHECKS.

FUEL SUPPLY. FIG 4

Tank, check for leaks-stability-height-position-vent. Check for leaks on the entire oil feed line from tank to appliance.

FUEL.

Check for correct grade.

FILTER. FIG 4

Is it fitted-check for function and leaks?
Oil line- check for function, positioning, material suitability and leaks.



FIRE VALVE. FIG 4
Check for function and leaks.

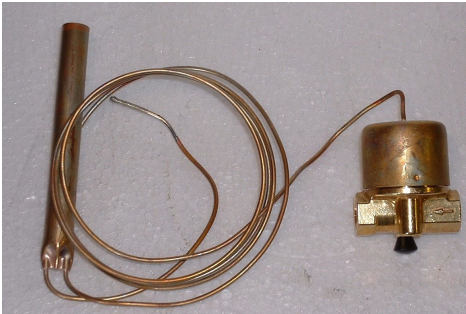

THROUGH BULKHEAD. FIG 4
Bulkhead fittings to be used.

ISOLATION VALVE. FIG4
Check for function, convenience of positioning and leaks.

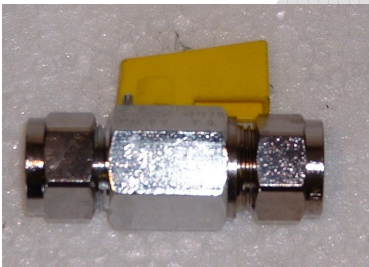

PURGING NEW OIL LINES. FIG 4
Flush at least 5 litres of oil through the line to check for contamination and to clear the oil line of installation debris and trapped air.

AIR LOCKING. FIG 4
Make sure that the oil feed supply pipe is level and has no potential for air locking. (Kinks, wavy runs, and sudden changes in level or slope).

ELECTRICAL.
Check for correct fusing, location and specification of any isolation devices.

VENTILATION.

Make sure that adequate ventilation is provided in line with boat safety scheme.

HYDRAULIC SYSTEMS. SEE FIG 5

Water systems should be pre-checked for leaks and tests must be made to make sure that water will flow freely through the boiler and that the boiler and pump is vented and free from trapped air.

Make sure that the heat leak circuit is adequate and unvalved.

CHIMNEY SYSTEM

Chimney heights must be a minimum of 1.8 meter for low fire use and 2.2 meter for high fire use.

Check the appliance is fitted with adequate clearances from combustibles.

Check that the combustion air restrictor is functioning correctly.

DISTANCES FROM COMBUSTIBLES

Make sure that both the appliance and flue system comply with the required distances from combustibles.

LIGHTING.

WARNING FOR BOILER APPLIANCES.

*If the appliance is fitted with a boiler, air locks or poor water flow through it may cause damage.
Make sure that the boiler has been vented of all air*

BEFORE ATTEMPTING TO LIGHT THE APPLIANCE.

Note; oven stoves are very efficient and as a consequence of this the flue pipe is slow to heat up. Most of the initial heat gets absorbed by the oven therefore before attempting to light the stove especially on a cold boat, it is advisable to pre heat both the burner pot and the flue pipe to make sure that the slug of cold air in the flue and appliance is rising and will allow air for combustion to be pulled into the burner pot. If the flue is not drawing air and the appliance is cold, fumes may well leak from the appliance and the ignition process can be long winded.

Lighting the appliance takes a little time and patience; the following procedure should be adopted.

Open the front door.

Remove the coal kit if it has been supplied with the appliance.

Remove the inner mesh catalyser



Turn the oil on at full rate and allow oil to flow into the bottom of the pot to form a pool about the size of a small digestive biscuit and then turn the oil off.

Do not allow any depth of oil to build up.

Light a small piece of firelighter (about the size of a pineapple chunk) and place it into the centre of the pot.

Replace the lower burning ring, the mesh catalyser and the coal kit and then leave the door slightly open whilst the firelighter gets the oil going.

If fume leaks out of the appliance this is a sign that the flue pipe is not hot enough and needs to be pre heated.

After 30 to 40 seconds, you will notice the flame start to establish itself and spread around the bottom of the pot.

When this occurs, close the door and turn the oil on to its minimum setting.

If the flame goes out or runs very sooty this is a sign that the flue is not hot enough.

After two or three minutes the flame should then slowly change from yellow into blue flame combustion and settle down to a steady burn.

Note there may be the occasional growl or audible vibration whilst the burner settles down into blue flame combustion.

Allow the burner 10 - 15 minutes to stabilise and the increase the flow of oil as required, moving by one increment of the dial only.

Do not leave the appliance unattended during the lighting and stabilising procedure.

COMMISSIONING THE HIGH AND LOW FIRE.

Adjustments should be made by reference to the oil valve booklet supplied with the appliance

Allow at least one hour for the chimney and appliance to warm up thoroughly before making any adjustments to the high or low fire screws.

When the burner has established good blue flame combustion turn it up to half output. (Setting 3 on the fuel flow control knob) and let it stabilize.

Turn the appliance down onto minimum firing rate and

let it stabilize.

After stabilization there should be a dull red glow in the catalyser with wispy blue flames flickering just over the top of it, approximately level with the top of the pot.

If the flame falls into a dirty rolling yellow flame and the catalyser is not dull red then the low fire will need to be increased until the burner can support the required blue flame combustion.

When you are happy with the low fire, set the high fire.

Turn the oil flow knob up to setting 4, let the flame stabilize, and look at it, if it is stable and blue, turn it up slowly using the control knob, letting it stabilize after each movement, *if the flame starts to go yellow with long flame combustion, it is running fuel rich and the high fire screw needs adjusting to reduce the flow of oil. (Screw the adjuster screw in to reduce the high fire oil flow.)*

Before adjusting the high fire screw, turn the flame down and let it stabilize in blue flame combustion, adjust the high fire screw by half a turn in and try turning the fuel flow up, if it is still fuel rich repeat the process until the high fire flame is running blue with flicks of yellow in the tips.

On the Socomef pot, the **high fire flame** will be set approx 40mm higher than the top of the pot.

CHECKING THE ACTION OF THE BUILT IN THERMOSTAT.

Boiler appliances have a thermostat assembly attached to the top of the oil control valve.

After the high and low fire has been set, check the action of the thermostat and overheat stat.

Do this by turning off the circulating pump and putting the appliance on to high fire.

As the boiler temperature increases the thermostat will shut the appliance down on to low fire, because the circulating pump is not working the boiler will carry on increasing temperature, at approx 80 deg C the safety stat will shut the oil valve down and the appliance will go out.

If this does not occur there could be a fault on the thermostat assembly.

8. FAULT FINDING HEATING SYSTEM.

If the system does not perform well check the following-:

THE CIRCUIT DESIGN. FIG 5

AIR LOCKED CIRCULATING PUMP. FIG 5

AIR LOCKED SYSTEM PIPEWORK. FIG 5

INADEQUATE SYSTEM PRESSURE HEAD.

INOPERATIVE CIRCULATING PUMP. FIG 5

INADEQUATE PIPE SIZING. FIG 5

INADEQUATE CALORIFYER DESIGN. FIG 5

INADEQUATE APPLIANCE LOCATION.

The appliance is fitted out of level, allowing an air pocket to build up in the top of the boiler, causing subsequent kettling and damage to thermostat sensing phial

FLOW OF WATER THROUGH THE BOILER. FIG 5

WATER THROUGH THE CALORIFYER.

FLOW OF WATER THROUGH THE RADIATORS.

THE SYSTEM IS NOT OVER PUMPING.

LACK OF PRESSURE RELEASE SAFETY VALVES.

FEED AND EXPANSION.

Is it fitted in the correct place?

9. FAULT FINDING COMBUSTION.

1. RACING.

1. Audible vibrations generated by the flame caused allowing by too much oil in the pot, too quickly.
1-1. Turn off the oil flow until the burner has settled down to a steady burn rate and then turn the fuel on again but don't let the flame go out otherwise the burner **MUST** be allowed to cool down fully before a re ignition is attempted.

2. FLUE VACUUM.

1. The pot type burner is extremely sensitive to flue vacuum variations.
2. Good combustion will not be possible unless our instructions on chimneys and flue vacuum are followed. See fig1
3. If the burner does not burn with a blue flame, recheck the chimney vacuum and oil flow rate.
4. If the burner does not run well check that the seals in the appliance are good and that there is no ingress of air into the appliance flue ways.
5. Check that the correct fuel oil is being used.
6. Check the levels.

3. BURNER RUNS SOOTY.

Comments made on this subject assume that the appliance has been running normally for some time. If the appliance soot's up this indicates that there is not adequate air for blue flame combustion or there is an excess of fuel.

Check that the chimney is working correctly. (This means pulling enough air into the burner to allow correct blue flame combustion to occur.

Check that the fuel is the correct type and quality. Check that the flow rates are correct.

Where burners are run at high fuel flow rates on low chimney vacuums, long unsatisfactory yellow flame combustion and bad sooting will occur.

To rectify this problem reduce the high fire flow rate screw on the Oil Control Valve until blue flame combustion occurs.

Never switch from low settings to high settings; a longer burner life will be achieved if the regulator is moved only by one number at a time leaving approx. one minute between each setting change.

4. BURNER DOES NOT LIGHT EASILY.

Read the instructions in the lighting section of this publication.

5. OIL WILL NOT ENTER THE POT.

Is there oil in the fuel tank?

Has the fire valve tripped?

Has the isolation valve been accidentally turned off?

Is the oil turned on at the oil flow control knob on the valve?

Is the oil feed pipe from the valve to the pot?

Blocked. (Unlikely)

Has the water stat tripped off on the aqua stat?

Has the aqua-stat been damaged by overheating.

To check this out, remove the aqua-stat from the valve and remove the phial from the boiler, re cock the valve and test fire the appliance. See Fig 4 Toby Valve document.

Note this type of damage is not covered by the warranty.

6. OIL SMELLS.

Visual check on all joints for obvious leaks.

Check that the descaling lever packing gland nut is adjusted.

7. DEFLOODING A FLOODED POT.

To carry out this procedure you will need -:

- a. A small leak proof plastic bag.
- b. A small sponge.
- c. A larger plastic bag for disposal of the residue.
- d. A pair of disposable plastic gloves.

If the pot becomes flooded, de flood it is as follows -:
Put a small plastic bag into the appliance and sponge from the pot into the bag, when the excess oil has been removed put the plastic bag and sponge into another plastic bag and dispose of it.

8. OPERATING OIL FLOW RATES.

OIL Flow rates in cc per minute.

Min	Max
4cc	10cc

Oil Flow Rates In litres per hour.

.24 litres	.6 litres
------------	-----------

Oil Flow Rates In litres per 24 hours.

5.76 litres	14.4 litres
-------------	-------------

Oil Flow Rates In litres per 7 x 24 hours.

40.32 litres	100.8 litres
--------------	--------------

10. ROUTINE MAINTENANCE.

Continuous running assumed.

1. EVERY 4 WEEKS-:

Operate the descaling lever by turning it completely two or three times.

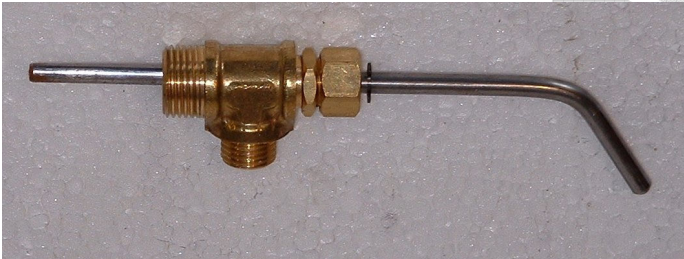

2. AS REQUIRED -:

Clean inside of door glass.

3. EVERY EIGHT WEEKS -:

Clean the burner completely by removing all the inner components as follows,

1. Open the front door.
 2. Remove the coal kit if it has been supplied with the appliance.
 3. Remove the inner mesh catalyser.
 4. Remove the lower burning ring.
- Scrape the bottom of the pot and remove all carbon build up.
Reassemble in the reverse order.

Corner appliance pot.



Section through corner appliance pot minus catalyser.

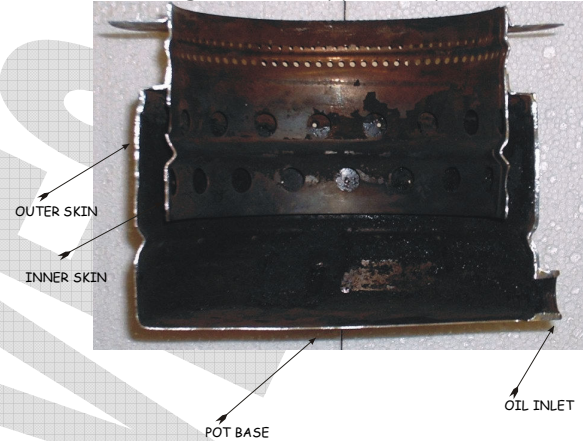

4. EVERY 24 WEEKS-:

4-1. Tighten up the compression nut on the descaling device to stop oil smells.

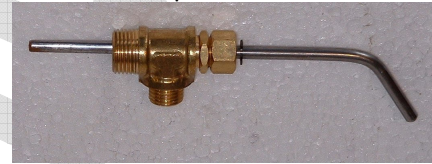

4-2. Section through descaling device.

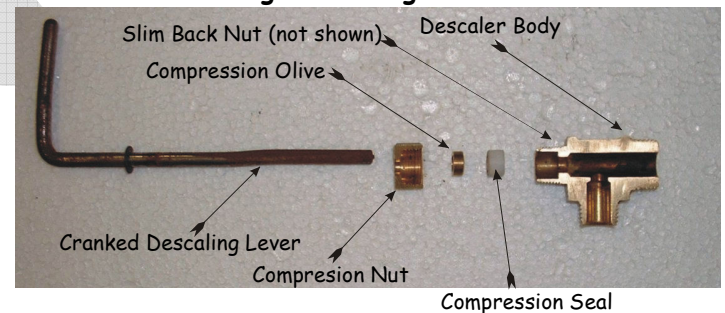

5. ONCE PER YEAR-:

Have your service man replace or clean all the filters in the oil supply line.

6. EVERY TWO YEARS -:

Have your service man clean the filter in the Oil Control Valve and check the function of all the safety equipment associated with the appliance, oil supply and plumbing system.
Remove and clean out the oil supply pipe from the valve to the pot.

7. AS REQUIRED -:

Keep the Coals, Coal kit, and burner inners in good condition, replace as necessary.

11. WARRANTY.

You are advised that if Harworth Heating Ltd is called out to appliances under warranty claims, where no

appliance fault can be found, charges will be made at the rate of £125.00 per hour, including travelling time.

Fill in the warranty form and returned it to us, the information recorded on the warranty form helps us to deal with any problems you may encounter.

Where we do not hold returned warranty forms replacement parts would only be issued when we are sure that the appliance has not been damaged by improper use or installation.

The warranty covers PARTS ONLY for a period of ONE YEAR and is conditional upon all the requirements

of our installation instructions being fully adhered to.

12. WARRANTY ITEMS NOT COVERED.

DOOR GLASS.

LABOUR COSTS.

TRAVELING COSTS.

CONSEQUENTIAL LOSS.

CONSEQUENTIAL DAMAGE.

14. APPLIANCE Distances from Combustibles

Appliance Type	ABOVE	BELOW	SIDES.	BACK	FRONT	HEARTH
BOAT B1	400	25	300	150 FROM HEAT SHIELD	400	25 THICK X 150
BOAT B2	400	25	300	150 FROM HEAT SHIELD	400	25 THICK X 150
BELFORT	400	25	300	150 FROM HEAT SHIELD	400	25 THICK X 150
CORNER	200	25	200	25 FROM HEAT SHIELD	300	25 THICK X 150
CORNER OVEN	150	15	200	25 FROM HEAT SHIELD	300	15THICK

ROUND	200	ALLOW 300 ALL AROUND THE APPLIANCE	25MM THICK HEARTH
-------	-----	------------------------------------	-------------------

Protection can be gained by the use of -:

- Sheet metal heat shields and spacers.
- Heat resistant boards.

Combustible materials can be-:

- Wooden furniture.
- Curtains.
- Wooden panels or frames adjacent to the flue pipe or where it passes through the deck of the boat.
- Carpet or flooring close to the appliance.
- Items near to the appliance, which could fall onto it and ignite, should the boat suffer a slight impact.

15. Flue Pipe Distances from Combustibles

For all appliances-:

150 for single skin pipes.

25 mm for insulated flue pipes.

16. Oil Supply Layout

FIG 4

CORNER STOVE OIL LAYOUT ISS 2

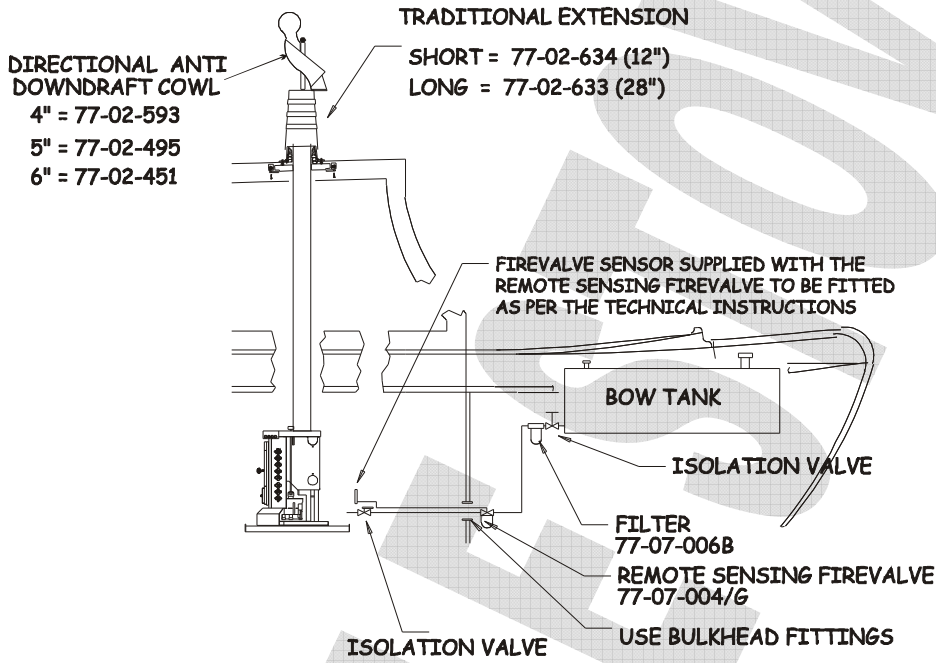

COPYRIGHT HARWORTH HEATING LTD 080800

17. Plumbing Layout Options

Each of the stoves has a different output to water and the installing engineer should first of all establish the boiler output to water and then design the heat losses accordingly.

Note that some of the boilers can only provide heat for a calorifier and towel rail.

FIG5

SCHMATIC GRAVITY SYSTEM ISS1 OF 08-07-01
READ IN CONJUNCTION WITH TECHNICAL INSTALLATION MANUAL

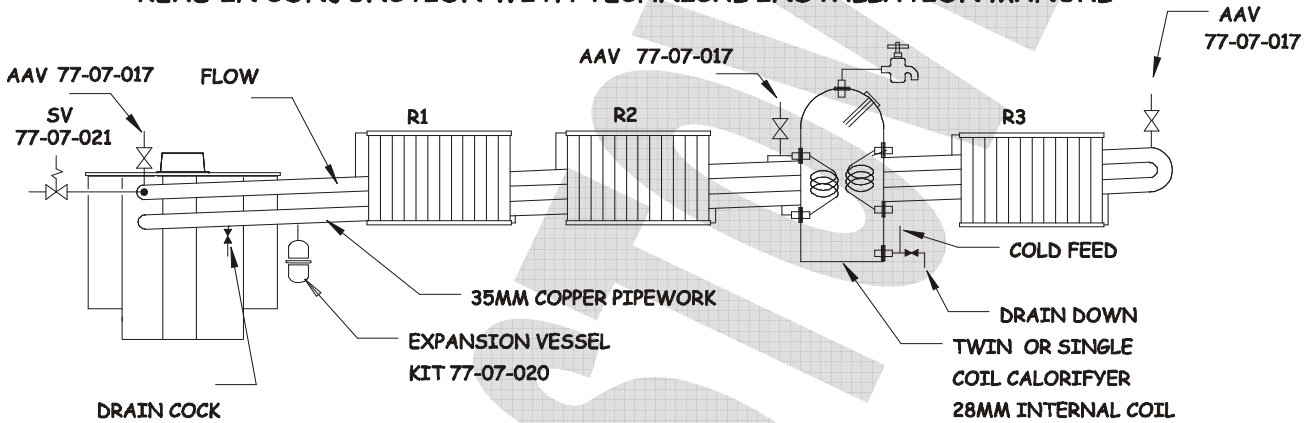

SCHMATIC PUMPED SYSTEM ISS1 OF 08-07-01

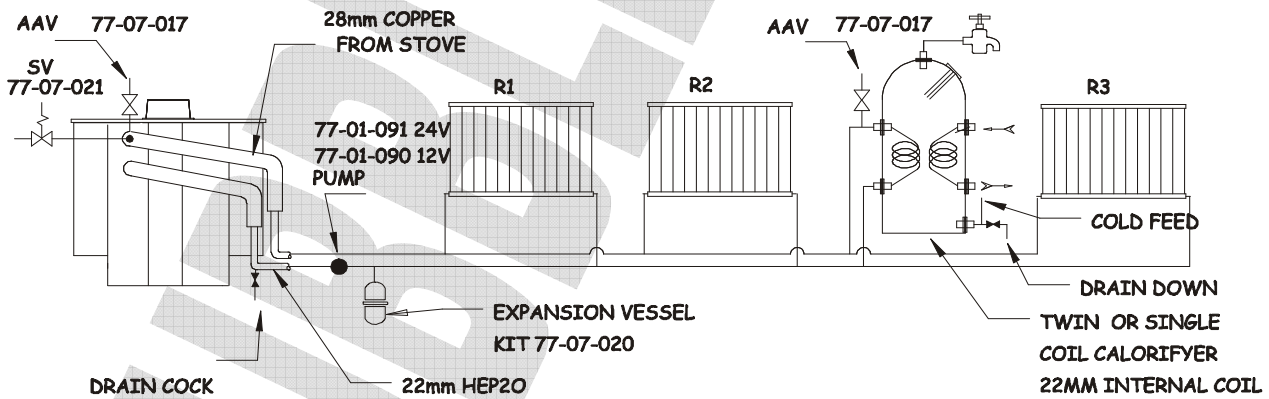

© HARWORTH HEATING LTD 30.6.98

This publication may not be copied by any means, without written permission from the authors.

This product is subject to continuous development and improvement and it is consequently acknowledged that due to this process there may be some omissions and errors.

This publication is intended only to assist the reader in the use of this product and therefore Harworth Heating Ltd shall not be liable for any loss or damage whatsoever arising from the use of any information, error or omission found in this guide.

Only approved personnel, WHO HAVE BEEN SUITABLY TRAINED, must carry out maintenance on this product.