



INSTALLATION INSTRUCTIONS 31-01-15

BUBBLE PJ MAX MARINE

230 VAC Automatic Pressure Jet Diesel Boiler Horizontal and Vertical versions
CE - C17873A 08-04-03

Front View Vertical Boiler



Front View Horizontal Boiler

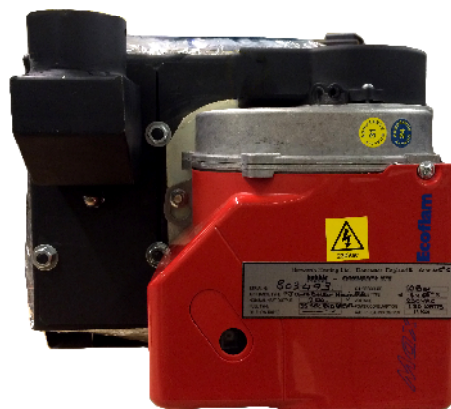

Index

| | |
|--|-----------|
| 1. Installation. | 16 |
| Power Supply. | 16 |
| Fuel supply. | 16 |
| Single Pipe System. | 16 |
| Two Pipe System. | 16 |
| Oil Layout. | 17 |
| Filter and KBB Fire valve set up. | 17 |
| Ventilation. | 18 |
| Flueing. | 18 |
| Fig 1. Vertical Flue Options for vertical and horizontal boilers. | 18 |
| Horizontal Flue Options. | 19 |
| Fig 2. Horizontal Flue-Inland Waterways. | 19 |
| Fig 2A. Horizontal Boiler with Horizontal Flue. | 20 |
| Fig 3. Horizontal Flue-Sea Going. | 20 |
| Prevention of Sea Water Ingress through the Side Flue Adaptor. | 21 |
| Fire Hazards. | 21 |
| Clearances From Combustibles for Vertical version. | 21 |
| Clearances From Combustibles for Horizontal version. | 21 |
| Fastening Down for vertical version. | 21 |
| Fitting and Fastening Down for Horizontal version. | 22 |
| Plumbing. | 23 |
| Hot water. | 23 |
| Schematic Grundfoss Twin Pump System. | 24 |
| Schematic Y Plan System. | 25 |
| Schematic S Plan. | 26 |
| Controls. | 27 |
| Schematic Wiring Layout for Y Plan. | 27 |
| Schematic Wiring Diagram. | 28 |
| Dimensions Vertical Version. | 29 |
| Dimensions Horizontal Version. | 30 |
| 2. Commissioning. | 30 |
| Commission the heating pressure system if fitted. | 31 |
| Check the heating system. | 31 |
| The effect of TRV's. | 31 |
| Check hot water system, expansion vessel and pressure release devices. | 31 |
| Checking the Flue Gas Emissions. | 31 |
| 3. Maintenance. | 32 |
| Service the Eco Flam Max Burner. | 32 |
| Service the Vertical Boiler. | 32 |
| Service the Horizontal Boiler. | 32 |
| Clean out the flue system. | 33 |
| Checking the oil line. | 33 |
| Checking the firevalves. | 33 |
| Checking the flue system. | 33 |
| Checking the provision of ventilation. | 33 |
| 4. Fault Finding. | 33 |
| Black Smoke is emitted from the flue terminal. | 35 |
| Grey smoke is emitted from the flue terminal. | 36 |
| Burner goes to lockout after initially firing up for a short period. | 36 |
| Burner locks out and will not attempt to Ignite. | 36 |
| Burner is completely dead with no lock out light showing. | 36 |
| External controls faults. | 36 |
| Inverter faults. | 36 |
| Flue and exhaust faults. | 36 |
| Vertical Boiler parts list. | 37 |
| Burner parts list. | 38 |
| 5. Warranty. | 39 |
| 6. Amendments. | 39 |

1. INSTALLATION.

To allow the best usage of space, the PJ auto boiler can be ordered as either a vertical or horizontal version.

See Fig 2 for vertical configuration

See Fig 2a for horizontal configuration.

For detailed burner information, read this literature in conjunction with the Ecoflam Max 1 burner booklet, LB1390 28-04-2006 which shows spares, wiring and maintenance details. A single boiler can produce an output of up to 14.6 kW, on larger vessels, where higher outputs are required one, two or more boilers can be fitted together on a low loss manifold system to provide higher outputs.

POWER SUPPLY.

The boiler-boilers can only be connected to a 230 Volt A.C. mains electrical supply or an equivalent full sign wave inverter.

The boiler-boilers must be connected to the electrical supply via a switch fused isolator with a 3amp fuse fitted.

The live, earth and neutral electrical connections made in the power supply plug are as per normal, UK convention.

The boiler-boilers must be adequately earthed.

FUEL SUPPLY.

The burner can be set up with the pump configured for a double or single pipe system.

Use a single pipe system if the burner is lower than the fuel tank. (POSITIVE HEAD)

Use a single or double pipe system if the burner is higher than the fuel tank. (NEGATIVE HEAD)

When installing a Negative Head, single pipe system, use a suitable de aerator such as a GOK and install it in line with the manufacturer's instructions. (We can supply the de aerator if required.)

SINGLE PIPE SYSTEM.

The best form of fuel supply is positive head, single pipe, gravity feed.

If single pipe, negative head is to be used then a de aerator must be fitted.

The de aerator must be mounted at burner level or slightly higher than burner level.

The de aerator must be fitted in a suitably ventilated engine room away from any heat sources.

If the de aerator is fitted inside a saloon or area designated as a living area then it must be of a suitable design.

TWO PIPE SYSTEM.

When the storage tank outlet is below the burner, the two pipe system should be used.

To prevent fuel draining back to the tank, a non-return valve should be fitted in the supply pipe together with a filter and a fire valve.

The return pipe should be at the same level in the tank as the supply pipe, both being 75 to 100 mm above the base of the tank and must be totally unrestricted.

The pipe ends should be a sufficient distance apart so as to prevent any sediment disturbed by the return oil flow entering the supply pipe.

Avoid the bottom of the tank being more than 3 m below the burner.

A micronic filter must be fitted in the fuel supply line adjacent to the boiler.

A shut-off or isolation valve should be fitted before the filter, to allow the filter to be serviced.

Flexible fuel lines to ISO 7840 should be inspected annually when the boiler is serviced and replaced every two years.

Fuel tanks and fuel lines should be installed to BS EN ISO 10088:2001.

Oil supply lines to the burner can be via 8 or 10 mm copper pipe, thick wall hydraulic grade is recommended.

For service requirements the boiler must be fitted with isolating valves and flexible hoses.

The objective of fitting flexible hoses to the burner is to allow the burner to be lifted easily from the boiler.

The isolating valves must be positioned so as to allow a service engineer to remove the burner from the boiler without excessive oil spillage.

For similar reasons, isolating valves should be fitted on the filter and the KBB remote sensing fire valve.

Make sure that the burner is not locked into place by tight fitting oil lines.

OIL LAYOUT.

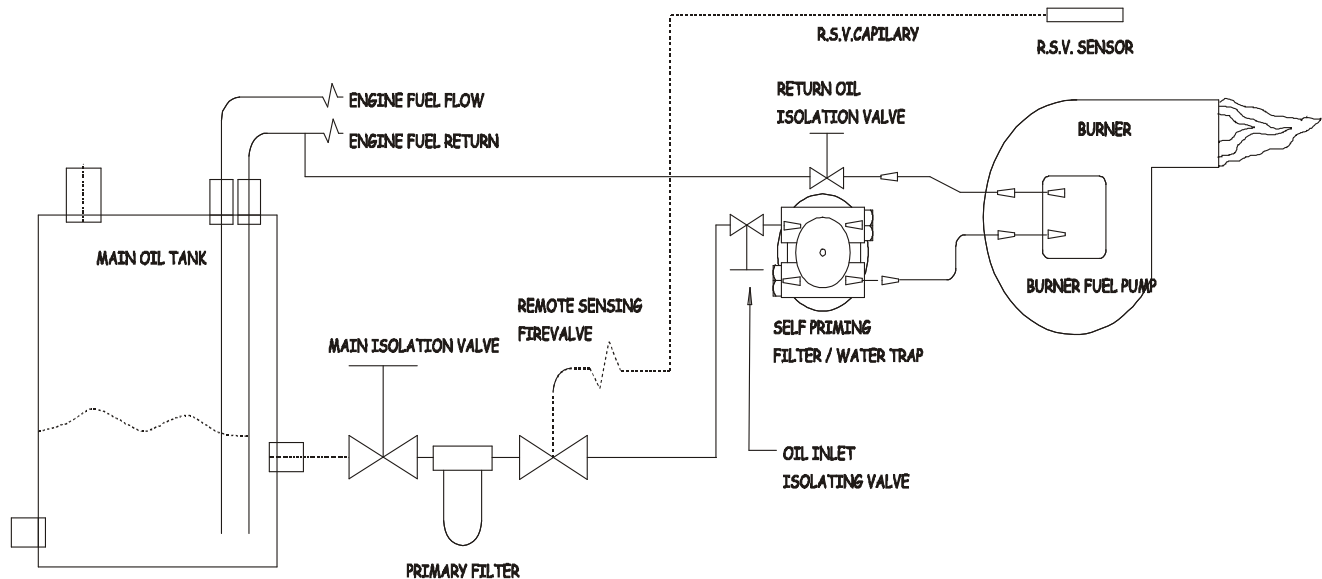

FILTER AND KBB FIRE VALVE SET UP.

Isolation valves should be fitted to either side of the remote sensing fire valve to allow for easy isolation and replacement should the valve fail.

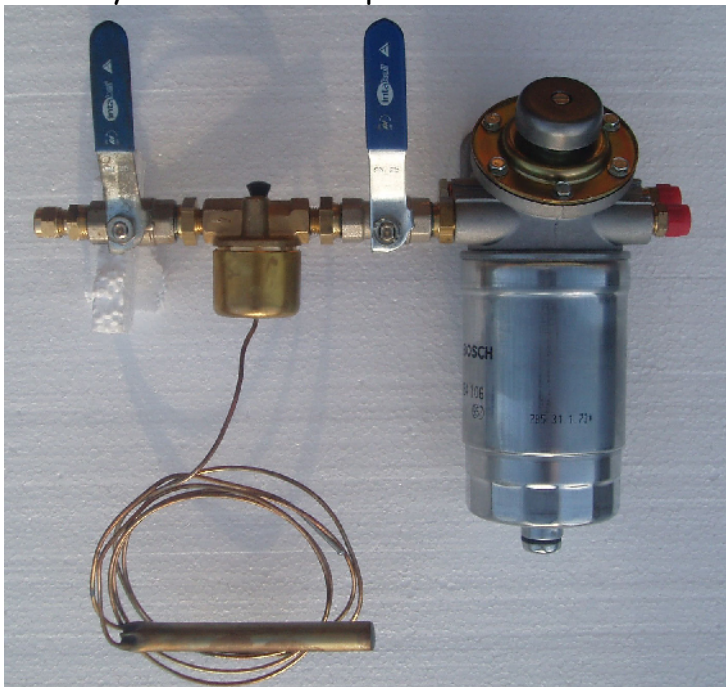

VENTILATION.

The boiler can only be fitted in an engine room, adequate ventilation must be provided and this will be calculated at 5cm sq per kW of output.

Note: - If the engine room is subject to a negative pressure air can be drawn into the compartment through the boiler flue system causing the boiler to be noisy and unreliable on start up.

A quick check for this situation is to check that air is not being exhausted out of the burner air inlet, if it is, and then the air inlet to the burner must be ducted from a suitable vent.

FLUEING.

The boiler is fitted with a vertical top flue take off.

The boiler can be flue'd horizontally if required via a 90 degree elbow, flexi stainless steel flue pipe and a through side adaptor.

FIG 1. VERTICAL FLUE OPTIONS FOR VERTICAL AND HORIZONTAL BOILERS.

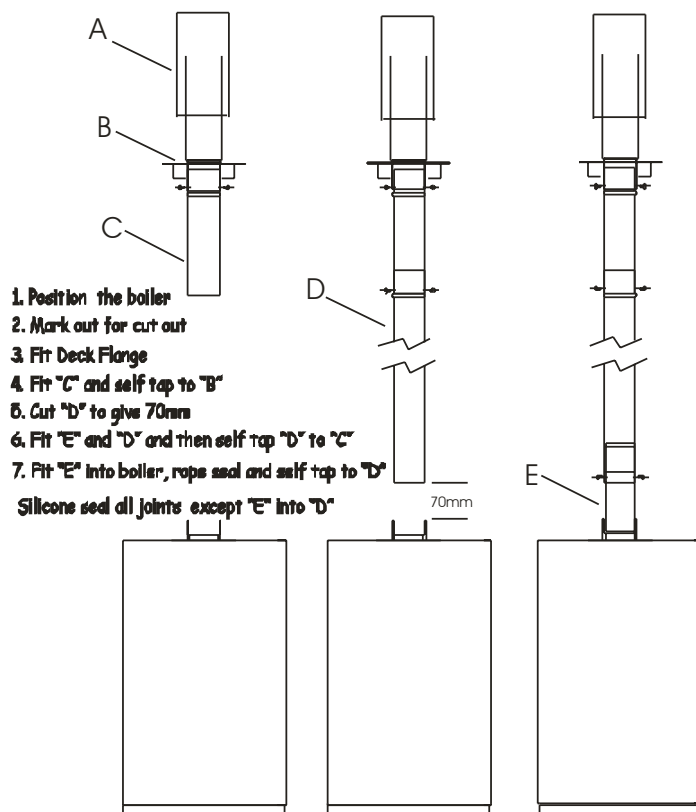

In all cases the horizontal or vertical flue pipe must be fitted so as to allow a vertical movement of 70mm min to facilitate boiler servicing.

On vertical flue applications this means that the lower part of the flue must be so designed so as to slide up into the upper part of the flue.

The upper part of the flue will need to be secured to the through deck adaptor so as to make it self-supporting when the lower part is not fitted to the boiler.

The flue pipe should be mechanically secured into the boiler outlet socket via two, stainless self tapping screws at 90 deg orientation

To prevent fire hazards, the flue pipe must be fully insulated or wrapped with glass fibre insulation.

HORIZONTAL FLUE OPTIONS.

TAKE CARE WHEN HANDLING THE CUT ENDS OF FLEXI FLUE. IT IS VERY SHARP AND SUITABLE LONG SLEEV GAUNTLETS MUST ALWAYS BE WORN

On vertical boilers, a 90 deg bend is fitted into the top outlet of the boiler; the bend has flat fibre glass sealing rope attached to form a good seal into the boiler outlet socket.

The bend should be mechanically secured into the boiler outlet socket via two, stainless self tapping screws at 90 deg orientation. When commissioning the boiler make sure that there are no fumes leaking from the flue outlet joint.

The flexi flue pipe is sealed into the bend using high temperature silicone sealant and at the other end the flexi flue pipe is fitted over the through side fitting and sealed using the black silicone sealant and the clamp band provided with the kit.

Make sure that the flexi flue pipe is always lagged using 75mm x 3mm lagging our pt no 87-06-020

The lagging should be over wrapped using aluminium foil tape pt no TAPE001.

Before applying the lagging put two stripes of HT silicone adhesive, our pt no 77-01-996, down either side of the flexi flue pipe to secure the lagging.

FIG 2. HORIZONTAL FLUE-INLAND WATERWAYS.

ALLOW ENOUGH MOVEMENT FOR FLU TO LIFT CLEAR OF SOCKET FOR SERVICING

STAINLESS SELF TAPPING SCREWS
ON EACH JOINT

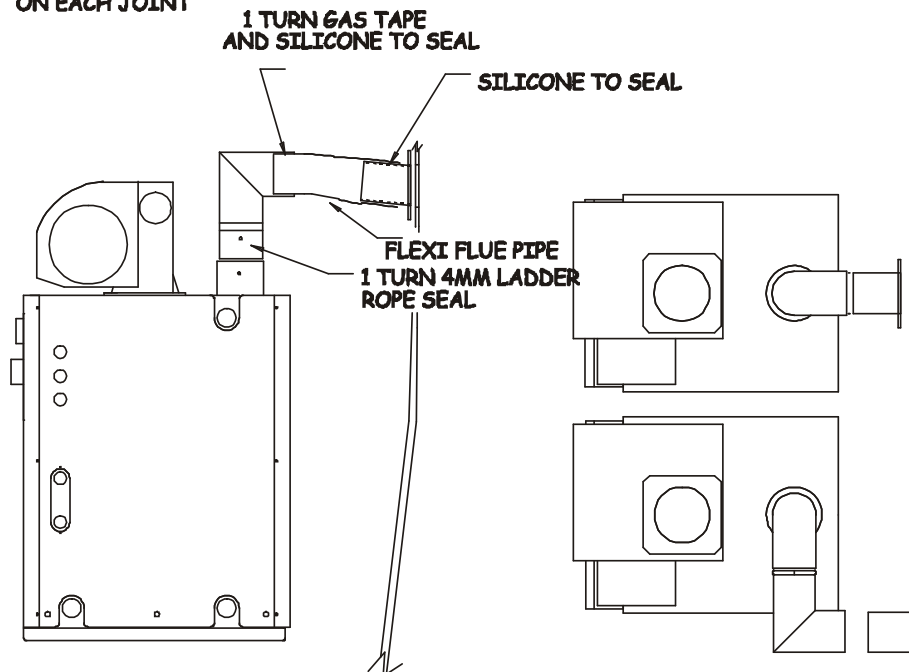
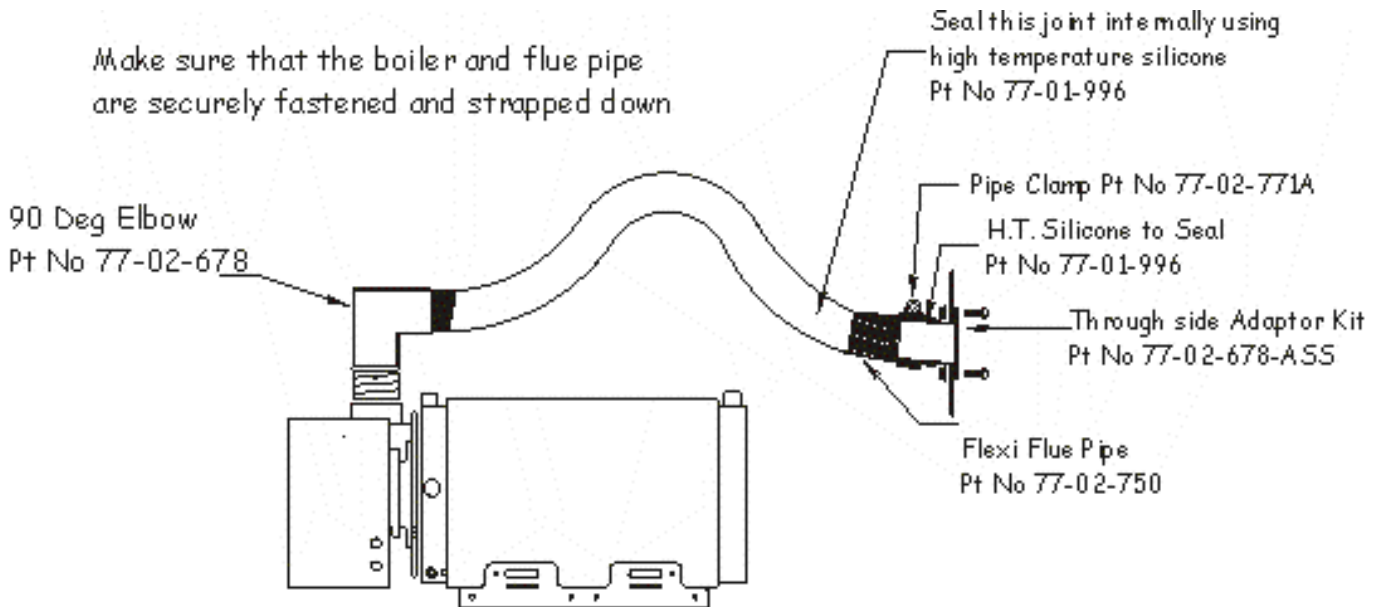

FIG 2A. HORIZONTAL BOILER WITH HORIZONTAL FLUE.



Note that for vertical flues fitted to the horizontal boiler the same set up as the vertical boiler can be used, see Fig 1.

FIG 3. HORIZONTAL FLUE-SEA GOING.

ALLOW ENOUGH MOVEMENT FOR FLU TO LIFT CLEAR OF SOCKET FOR SERVICING

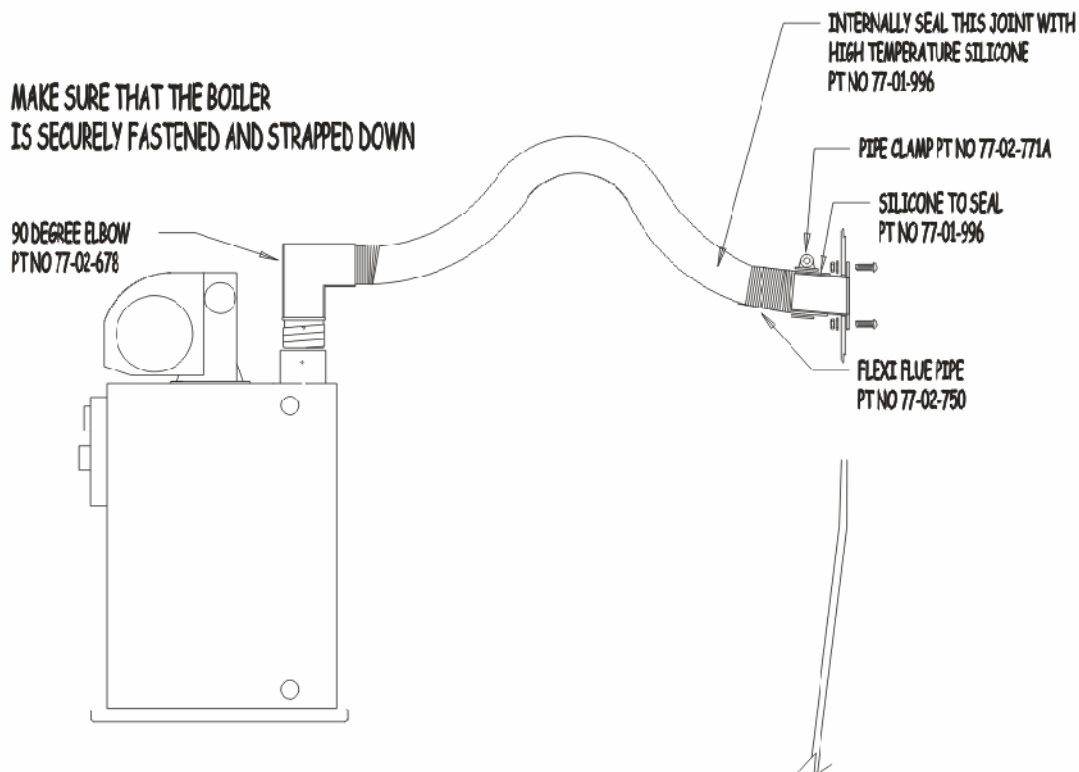

Where vessels are likely to go to sea take adequate precautions to:-
Prevent sea water entering the boiler via the side flue connection.
Make sure that the boiler is securely fastened to the vessel via both vertical and horizontal fixings.

PREVENTION OF SEA WATER INGRESS THROUGH THE SIDE FLUE ADAPTOR.

The through side adaptor is designed with a 10 degree angle to offset the possibility of water entry, in addition to this, sea going vessels must have an adequately designed swans neck to prevent water ingress into the boiler.

The orientation of the 10 degree's is marked via two small cut outs on the outer diameter of the adaptor. The adaptor is provided with a series of holes through which it can be bolted to the hull side plates and adequately sealed with high temperature silicone seal.

In all cases the horizontal or vertical flue pipe must be fitted so as to allow a movement of 70mm min to facilitate boiler servicing.

FIRE HAZARDS.

To prevent fire hazards, the horizontal or vertical flue pipe must be fully insulated with a fireproof wrap, the temperature of the flue outlet is likely to be around 230 deg C depending upon the duty cycle of the boiler.

Make sure that combustible materials are at the safe distance from the flue pipe as detailed below.

CLEARANCES FROM COMBUSTIBLES FOR VERTICAL VERSION.

Clearance Sides 0mm

When fitting the boiler make sure that the burner oil pump is not fitted tightly up to a wall or panel, the commissioning and service engineers will have to gain easy access to adjust the fuel pump pressure and from time to time replace the flexi fuel feed hoses.

Clearance Base 0mm

Clearance Back 0mm

Clearance Front 0mm

Clearance above 200mm

Clearance from uninsulated flue pipe 150mm.

Clearance from insulated, twin wall flue pipe 25mm.

To prevent fire hazards and danger to service or operator personnel, the horizontal or vertical flue pipe must be fully insulated.

To prevent a blockage of the burner air inlet, do not allow any loose materials such as dusters, wiper cloths, paper towels etc within 200mm of the burner.

CLEARANCES FROM COMBUSTIBLES FOR HORIZONTAL VERSION.

Clearance Base 0mm

Clearance Back 0mm

Clearance Front 200mm

Clearance above 50mm

Clearance from uninsulated flue pipe 150mm.

Clearance from insulated flue pipe 25mm.

FASTENING DOWN FOR VERTICAL VERSION.

The boiler must be securely fastened down; the degree of security depends on the marine category of use. Category C and D, use the 4 off standard clips provided.

Category B, optional special fixing brackets can be welded to the drip tray.

Category A, additional fixing straps and support frame would be required for both horizontal and vertical security.

FITTING AND FASTENING DOWN FOR HORIZONTAL VERSION.

For safety in transport the horizontal boiler is delivered strapped down to its base frame with the thermostat files fitted to the boiler phial sockets.

To fix the boiler support frame down to a secure base, proceed as follows: -

1. Remove the straps.
2. Remove the thermostat phials from the boiler (Fig 5), note that the thermostat phials are held in place by a small bent wire which is fitted in a cross drilling at the end of the phial holder tube which should be pulled out using a pair of snipe nosed pliers. When the securing wires have been removed gently pull out the sensors to allow the boiler to be lifted free from the base support plate.

(Take great care with the phials and capillaries, do not kink the capillaries.)

3. Lift the boiler up and off the support frame and then fasten the support frame down.

The boiler must be securely fastened down, the degree of security depends on the marine category of use either A, B, C or D.

The horizontal base frame has pre cut holes provided for fastening it down to a secure base.

When the base frame has been securely fastened down, the boiler is positioned equi spaced on it and then strapped down to it using suitable straps which are fitted through the slots in the base frame.

Fig 4 Base Support Frame

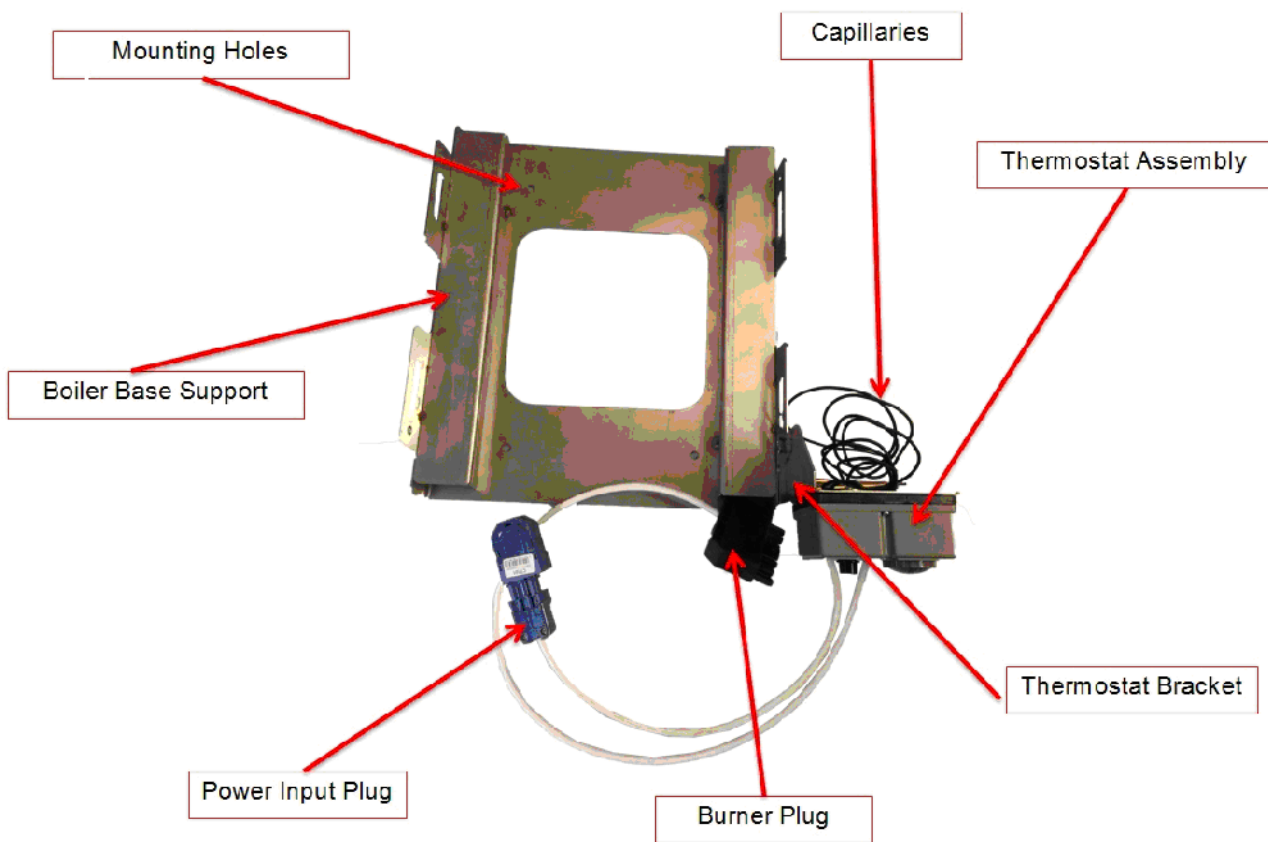
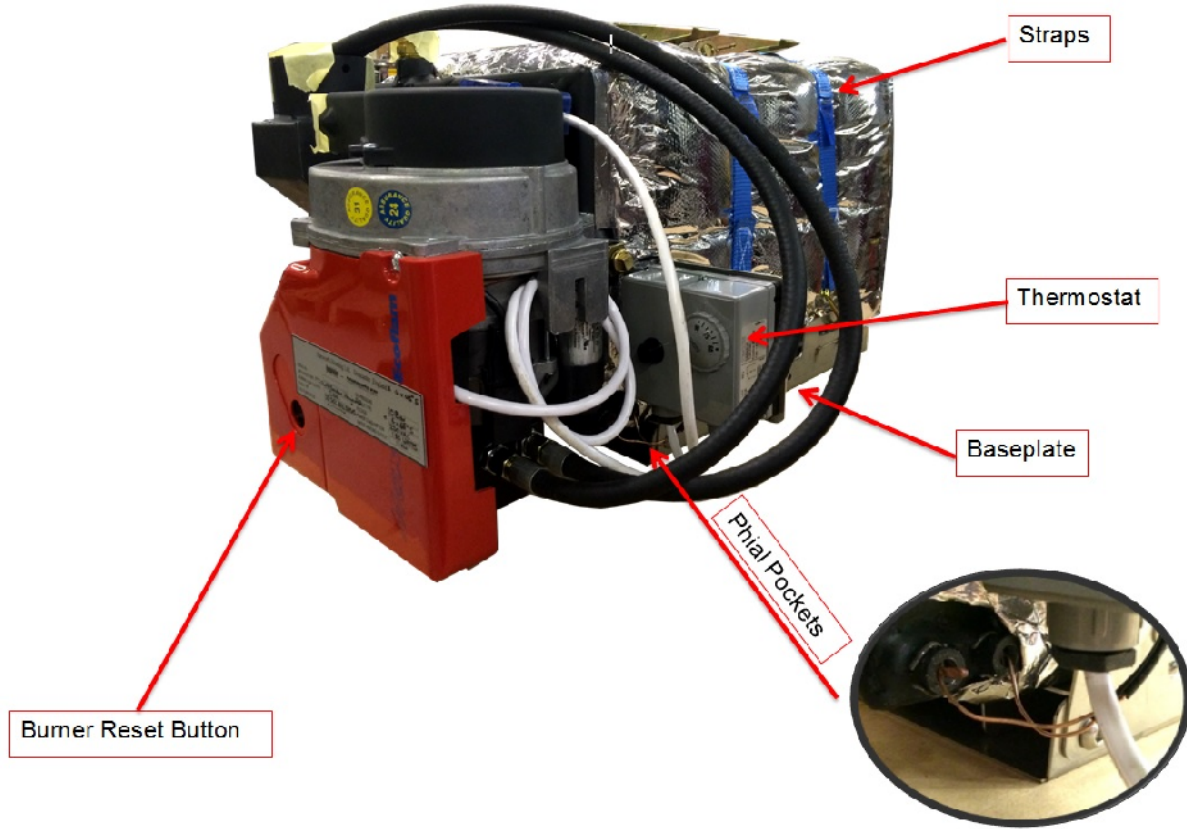

Fig 5 General Side View of Horizontal Boiler.



PLUMBING.

Connection to the boiler is made via two $\frac{3}{4}$ " B.S.P.T. male fittings.

It is assumed that the boiler will be installed using conventional pipe layouts and controls.

All pipe work (Primary and Secondary) must be free of air traps, where there is a potential for air traps to occur, automatic air vents must be fitted.

HOT WATER.

Hot water can be supplied by a calorifier.

The size of the calorifier would be determined by the space available and the volume of hot water requirement.

For showering a 60 litre capacity should suffice, for baths a 200 litre capacity would be required

Where unvented systems are used the calorifier must be of a suitable design with a high recovery coil fitted.

SCHEMATIC GRUNDFOSS TWIN PUMP SYSTEM.

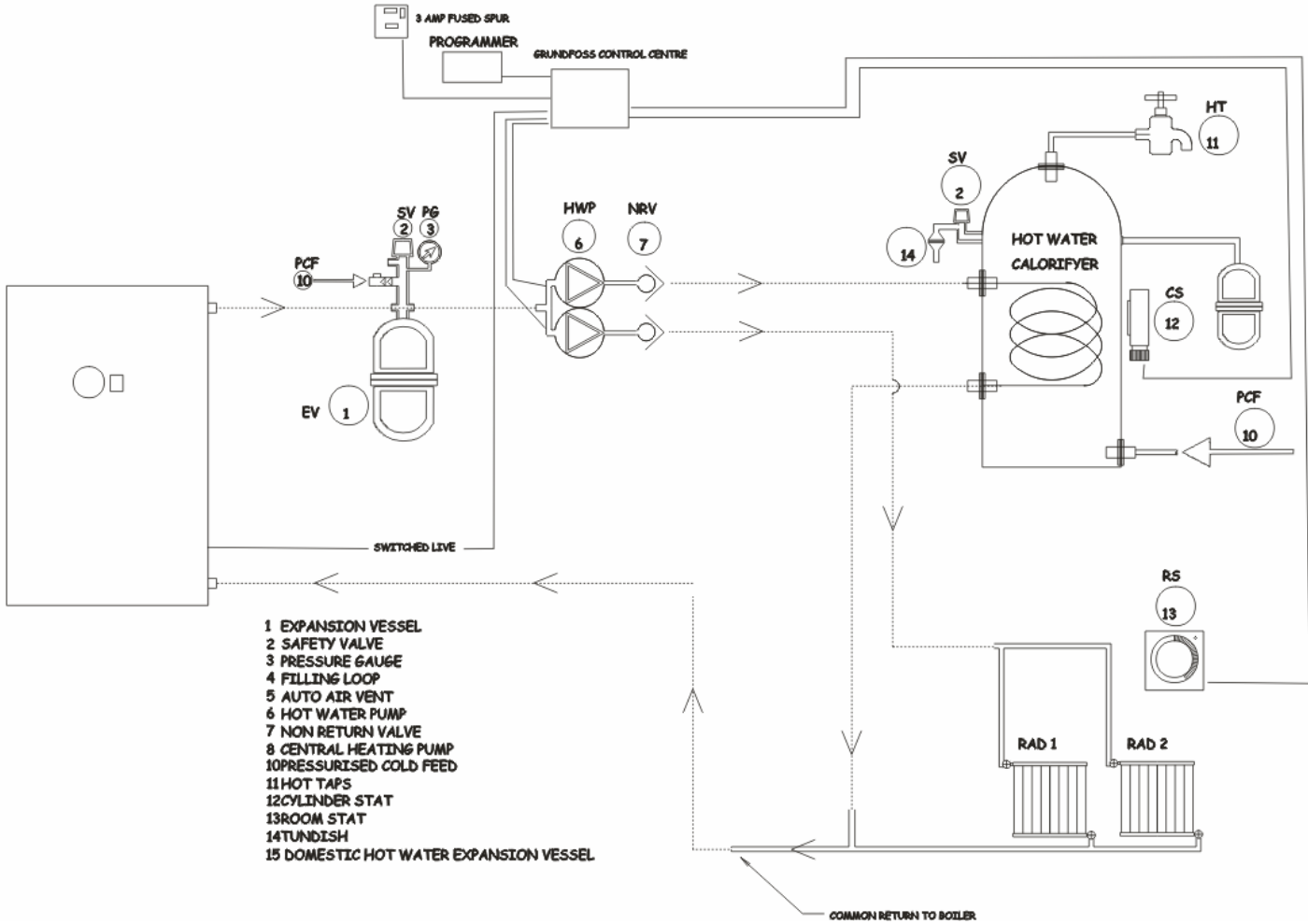

- 1 EXPANSION VESSEL
- 2 SAFETY VALVE
- 3 PRESSURE GAUGE
- 4 FILLING LOOP
- 5 AUTO AIR VENT
- 6 HOT WATER PUMP
- 7 NON RETURN VALVE
- 8 CENTRAL HEATING PUMP
- 10 PRESSURISED COLD FEED
- 11 HOT TAPS
- 12 CYLINDER STAT
- 13 ROOM STAT
- 14 TUNDISH
- 15 DOMESTIC HOT WATER EXPANSION VESSEL

SCHEMATIC Y PLAN SYSTEM.

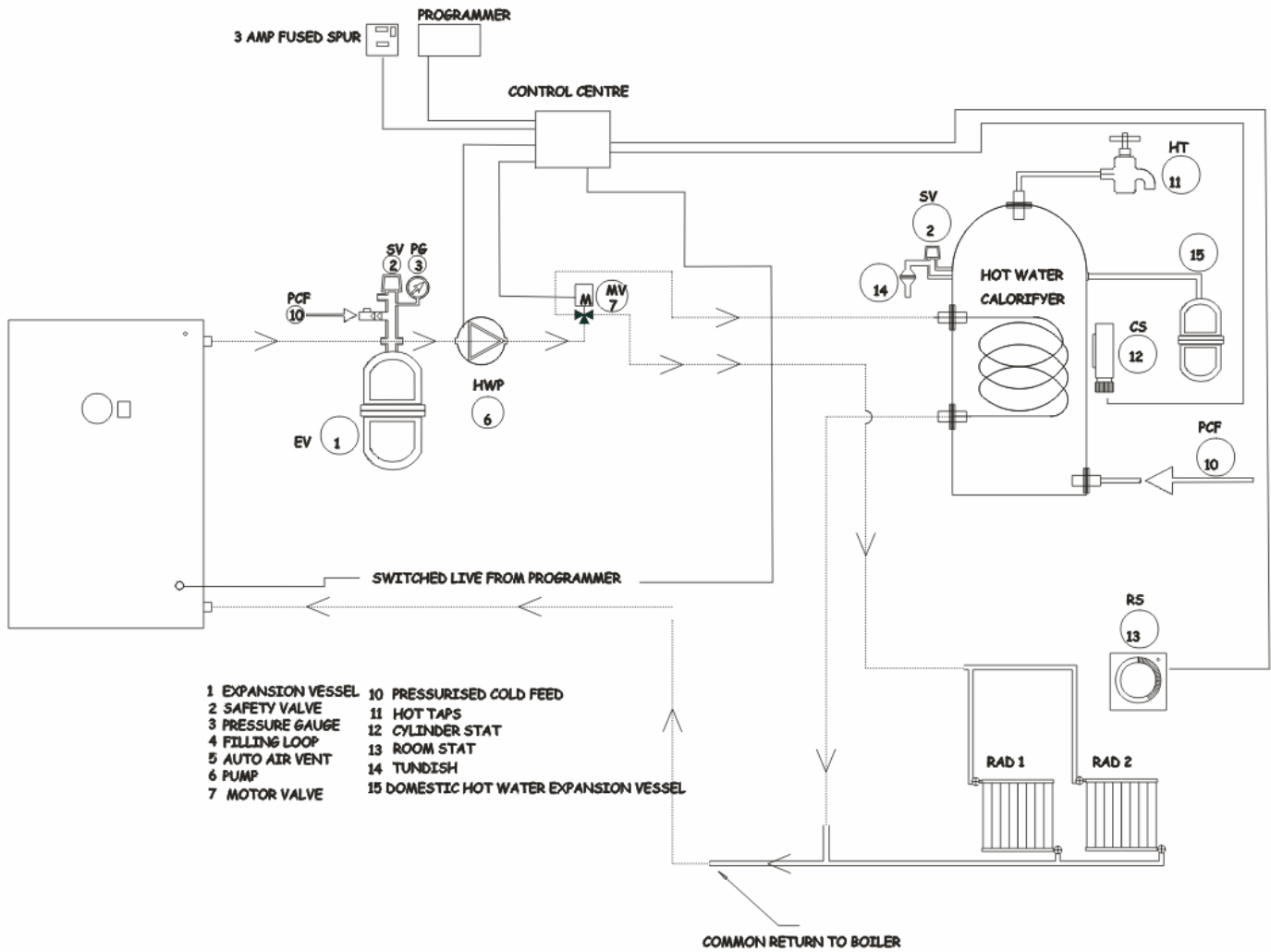

SCHEMATIC S PLAN.

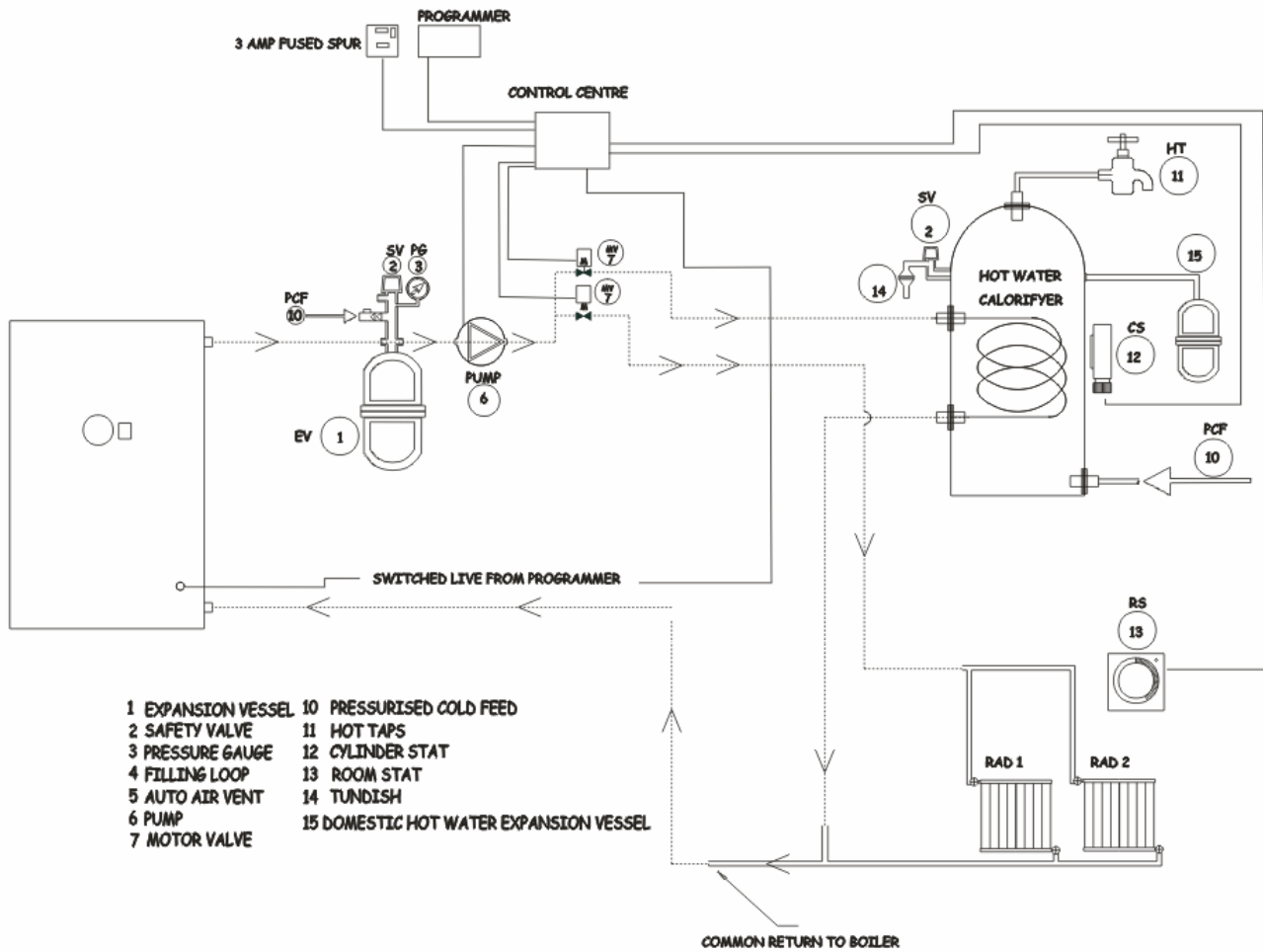

CONTROLS.

Typical control is by either Y plan, S plan or Pump plan.

Third party control systems will have detailed wiring instructions provided with the package of components which will usually comprise of -:

TIME CLOCK PROGRAMMER.

EITHER ONE THREE PORT, (Y Plan) OR TWO SINGLE PORT, (S Plan) MOTOR VALVES.

ROOM STAT.

CYLINDER STAT.

WIRING CENTRE.

Make sure that all wiring into the boiler is correct polarity.

Only qualified electricians are allowed to carry out electrical work on 230vac wiring and systems.

SCHEMATIC WIRING LAYOUT FOR Y PLAN.

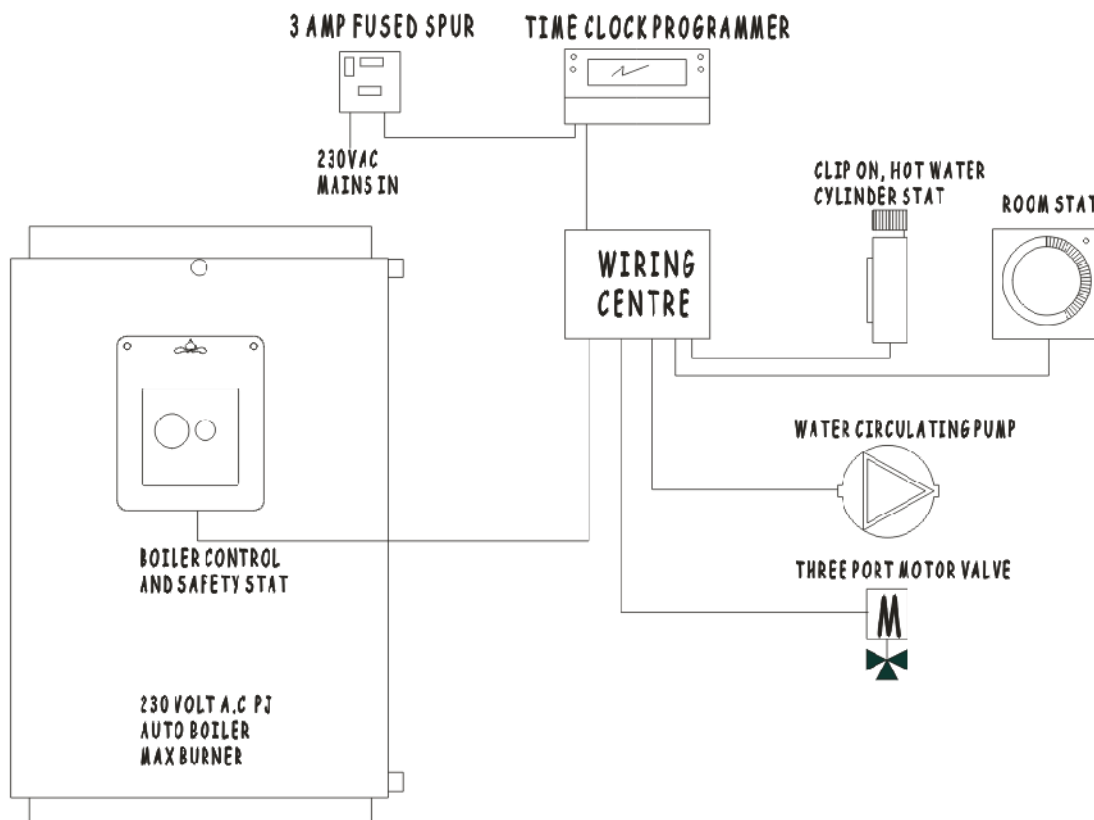

SCHEMATIC WIRING DIAGRAM.

Max Burner with Thermowatt wiring layout.

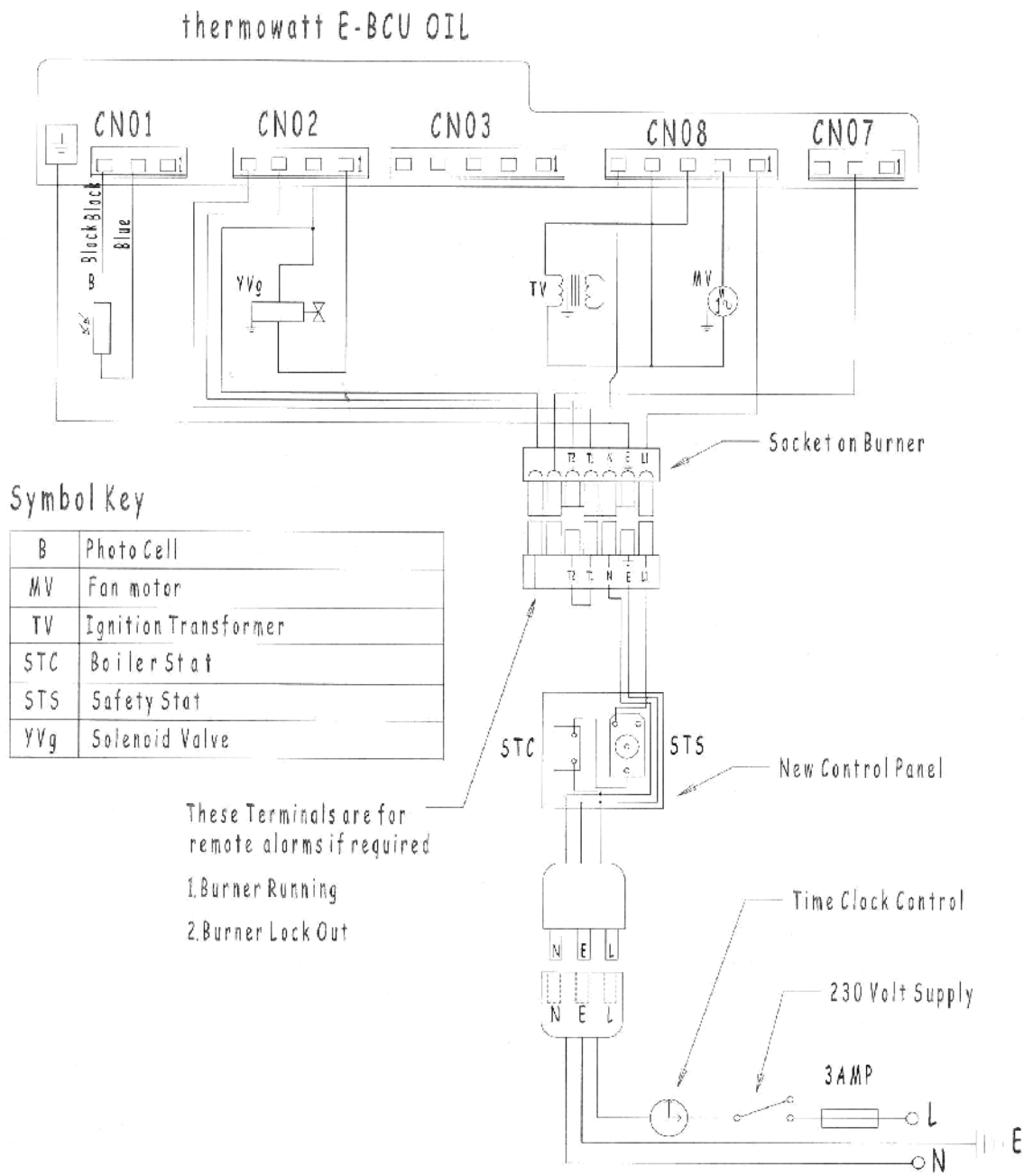

DIMENSIONS VERTICAL VERSION.

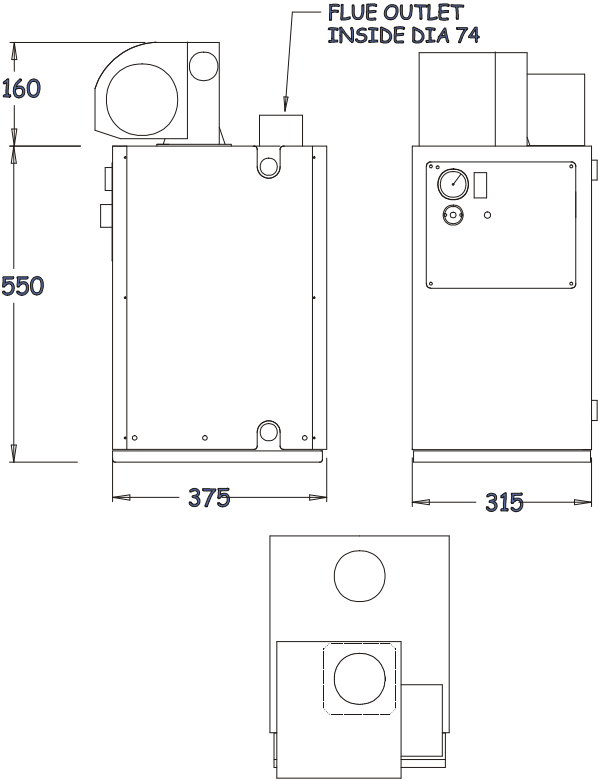

DIMENSIONS HORIZONTAL VERSION.

1. Note that the thermostat control box can be fitted to the right side, left side or remotely from the burner, please specify when ordering.
2. Note that the thermostat control box can be fitted at a maximum distance of 750mm from the boiler, if this is required then advise our sales team accordingly, when placing an order.
3. Note that there must be enough space in front of the boiler to allow the burner to be withdrawn horizontally from the front of the boiler for servicing the burner and cleaning out the boiler.

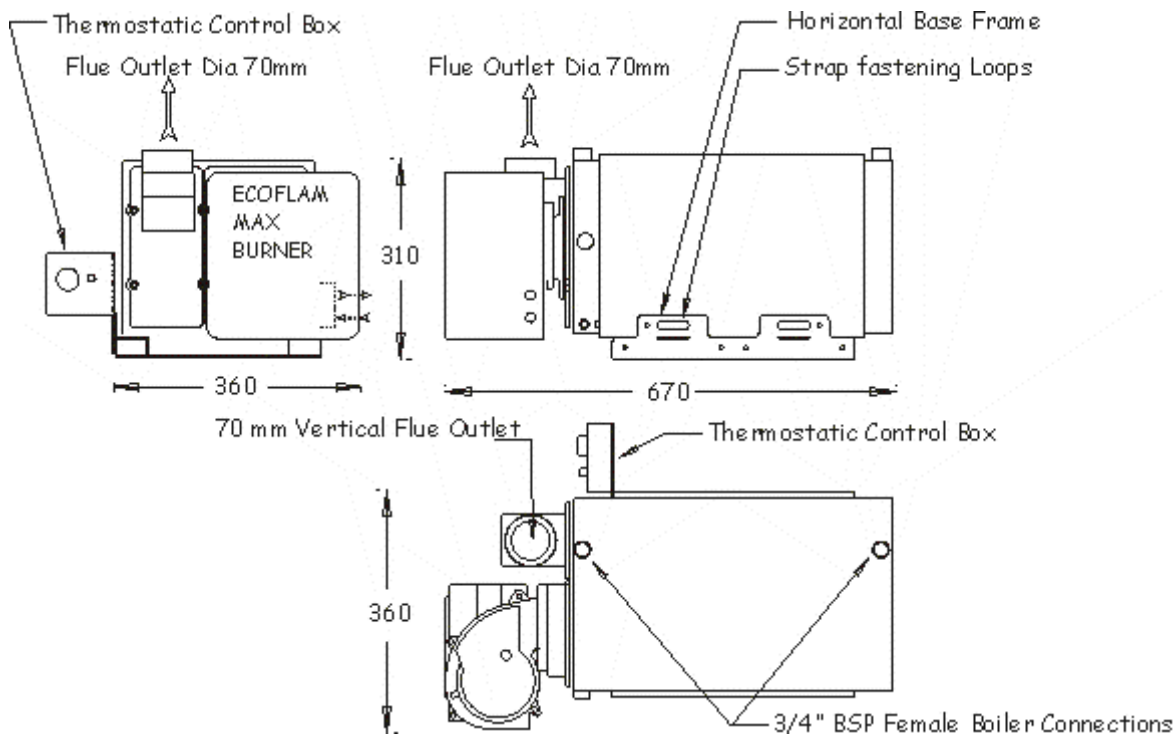

2. COMMISSIONING.

Before attempting to fire the boiler you will need to make sure that:-

- ❑ Air is not blowing out of the burner air intake, if it is this would indicate that the area or space in which the boiler is fitted is under a negative pressure which could stop the burner firing correctly.
- ❑ Using the temporary filling loop, fill the central heating system and vent all air from it; watch the pressure gauge and pressurise the heating circuit up to 1.5 bar.

(It may be necessary to keep topping up until the system until it is vented of all air, when it is, the pressure gauge should hold at 1.5bar.)

- ❑ Make sure that the boiler, the hot water and heating systems are free from air or air locks, air in the boiler could stop the pump from circulating and cause the burner to rapidly shut down.
- ❑ If fitted, make sure that the programmer, room stat, the cylinder stat, and the boiler stat are all set to call.
- ❑ If the boiler is fed with oil via a negative head oil supply, use the ignition process to pull oil from the tank and up to the burner, air can be vented from the fuel pump. It may need several ignition attempts to pull oil through from the fuel tank to the

burner fuel pump. When the oil supply is purged through to the burner, it is sometimes possible to hear the return oil trickling back into the fuel tank.

- ❑ If the burner does not fire it will lock out after the ignition attempt, to reset it, press the red button on the burner control box.
- ❑ Make sure that any flexible oil lines are manufacture to the standard ISO 7840
- ❑ If the boiler stat becomes satisfied it will shut the burner down.
- ❑ It is normal for the boiler to pulse on and off; up to its maximum operating temperature.
- ❑ Check the flue system and make sure that there are no fumes leaking from it, check the flue connection at the boiler and the flue connection to the through deck fitting.

COMMISSION THE HEATING PRESSURE SYSTEM IF FITTED.

Check the action of all pressure release devices.

Using the temporary filling loop, fill the central heating system and vent all air from it.

Watch the pressure gauge and pressurise the heating circuit up to 1.5 bar.

It may be necessary to keep topping up until the system until it is vented of all air, when it is, the pressure gauge should hold at 1.5bar.

Make sure that the temporary filling loop is disconnected.

Check that all off the safety devices are functioning correctly.

CHECK THE HEATING SYSTEM.

Make sure that all the vents are closed off and balance the system to provide equal flow across all the radiators.

THE EFFECT OF TRV'S.

If you intend to fit TRV's to the heating system you will need to fit a 22mm differential by pass valve.

The by pass valve will be fitted in between the output of the circulating pump and the three port or two single port motor valves as shown on he various hydraulic layouts.

CHECK HOT WATER SYSTEM, EXPANSION VESSEL AND PRESSURE RELEASE DEVICES.

To fill the hot water system open all the hot taps and admit water into the cylinder, check all the joints as the cylinder fills up and vent off all trapped air via all the hot outlets.

When the air has vented off, close the hot outlets and allow the system to come up to pressure.

Check all the pressure release devices and repeat the checks when the cylinder is up to temperature

CHECKING THE FLUE GAS EMISSIONS.

Generally the burner air setting needs to be at its lowest setting on the air scale.

Before proceeding with testing the flue gas make sure that: -

You have Dwyer test point plugs and a suitable size of drill.

You have suitable Allen keys.

Your flue gas analyser is in good condition and set for the appropriate fuel.

Drill a suitable hole into the flue approximately 100 mm from the boiler outlet to allow insertion of the flue gas analyser probe.

Fire the burner up and allow the boiler to come up to 60 deg C.

(Whilst the boiler is coming up to temperature keep an eye on the terminal, if there is smoke about increase the air until it goes.)

| | |
|--------------------|-------------------------------------|
| Nozzle Danfoss | 0.4 U.S. gal x 45° S. |
| Fuel Pump pressure | 10 bar. |
| Smoke | Zero to one on the Bacharach scale. |
| Efficiency | 86 to 87%. |
| CO ² | 10.5%. |
| O ² | 6 to 6.5%. |

3. MAINTENANCE.

Depending upon the intensity of its use, the boiler should be serviced once or twice per year.

OFTEC registered, oil fired service engineers will be able to service the boiler as per the routine maintenance section.

OFTEC can be contacted on 0845 65 85 080 they have details of all registered service engineers in the UK.

www.oftec.org

Before any service work is carried out make sure that the appliance is fully and safely isolated.

Note that on horizontal boilers there must be enough space in front of the boiler to allow the burner to be withdrawn horizontally from the front of the boiler for servicing the burner and cleaning out the boiler.

(Approx 100mm)

Note that on vertical boilers there must be enough space above the boiler to allow the burner to be withdrawn vertically from the top of the boiler for servicing the burner and cleaning out the boiler. (Approx 100mm)

SERVICE THE ECO FLAM MAX BURNER.

Remove the burner from the boiler.

Remove and clean the dust from the internals and externals of the burner.

Clean the air diffuser and flame tube.

Change the nozzle every second year. (Danfoss .4 x45 deg solid)

Examine and if necessary adjust the electrode.

Remove and clean the photocell.

If considered necessary, check the fuel pump pressure.

SERVICE THE VERTICAL BOILER.

Remove the burner from the boiler.

Slip the flue pipe up away from the boiler flue spigot.

The boiler has front and rear removable top plates held in place by 6 x m10 fasteners.

Undo the fasteners and remove the front top plate under which is a ceramic top board 87-01-900-72. and then remove the rear top plate.

When the rear top plate has been removed withdraw the 4 baffles underneath it.

Clean all of the internals of the boiler and vac the debris out making sure that all the internal surfaces of the boiler are clean and soot free.

When this is done, rebuild the boiler in reverse order.

SERVICE THE HORIZONTAL BOILER.

Remove the burner from the boiler.

Slip the flue pipe up away from the boiler flue spigot.

The boiler has front and rear removable front plates held in place by 6 x m10 fasteners.

Undo the fasteners and remove the right hand side access plate under which is a ceramic top board 87-01-900-72.

Then remove the left hand side access plate and withdraw the 4 baffles behind it.

Clean all of the internals of the boiler and vac the debris out making sure that all the internal surfaces of the boiler are clean and soot free.

When this is done, rebuild the boiler in reverse order.

CLEAN OUT THE FLUE SYSTEM.

After cleaning and servicing both the burner and the boiler, make sure that the flue system is clean and free from obstruction.

Using a small 70mm dia flexi brush, clean the flue system out every year.

CHECKING THE OIL LINE.

Flexible oil lines are prone to deteriorate, check them for leaks every year and replace as necessary.

CHECKING THE FIREVALVES.

The boiler must be fitted with a 60 deg C, remote sensing fire valve, which should be inspected and tested every year.

The sensor of the valve should be located over the boiler at a distance of 200mm above the burner.

CHECKING THE FLUE SYSTEM.

The flue system needs to be checked to make sure that it is airtight and working correctly.

There are three potential situations:-

1. Positive air pressure where smoke is drawn into the boiler and out through the flue system.
2. Neutral pressure where smoke does not go into or out of the boiler.
3. Negative air pressure where smoke is blown out of the burner air intake.

If the compartment in which the boiler is subject to a negative pressure, air can be drawn into the compartment through the flue system, boiler and burner.

A quick check for this situation is to check that air is not being blown out of the burner air inlet, if it is then the air inlet to the burner must be ducted from a suitable vent.

Use a smoke bomb to carry out this procedure.

CHECKING THE PROVISION OF VENTILATION.

Make sure that the boiler has adequate ventilation for cooling and combustion purposes.

Check on a regular basis and make sure that all purpose made vents are free from obstruction.

In certain cases where negative air pressure is encountered either permanently or intermittently, it may be necessary to duct air into the burner air inlet from an outside source.

Checking the fuel filters and change where necessary.

The fuel filter should be changed every year but this depends upon the cleanliness of the fuel, if the tank is contaminated or infected with diesel bug then appropriate cleaning out measures will be necessary.

If there has been a water or bacterial contamination, clean out the tank and replace all filters.

Dirt in the fuel line will cause nozzles to block or emit a uniform fuel spray pattern.

If there are any air leaks on the fuel supply, this can cause the boiler not to start cleanly.

4. FAULT FINDING.

In the unlikely event of a malfunction check the following:-

If you have a side outlet flue and you have recently been to sea or in rough water conditions and the boiler refuses to fire up, remove the burner from the mounting flange, then remove the top plate and top board.

Look down into the flue ways and make sure that there is no water in the bottom of the boiler.

If the boiler is free from water contamination, check the following.

1. Is 230 volt ac connected to the boiler and live? If power is supplied through a landline, is the supply 230V? Supply voltages can vary substantially in response to the combined applied load of other vessels
2. Is there fuel oil in the supply tank?
3. Are all or any shut off valves open?
4. Has the KBB remote sensing fire valve tripped off?
5. Are all controls such as the time clock and boiler stat set correctly?

To help sort out problems with your burner Ecoflam have produced an optional digital diagnostic device which plugs into the burner control unit and can be used to access stored historical data as detailed under Service - Troubleshooting below.

Service - Troubleshooting

Fault diagnosis and repair

In the event of a malfunction, first check that the prerequisites for correct operation are fulfilled:

1. is the system connected to the power supply?
2. is there oil in the tank?
3. are all shut-off valves open?
4. are all control and safety devices, such as the boiler thermostat, low-water detector, limit switch, etc. adjusted correctly?

If the malfunction persists, use the following table.

It is not permitted to repair any components relevant to safety. These

components must be replaced by parts with the same order number.

Only use original spare parts.

NB: after each operation:

- under normal operating conditions (doors closed, hood fitted, etc.), check combustion and check the individual lines for leaks.
- Record the results in the relevant documents.

E-BCU display interface must be used to read the faults by service personnel.

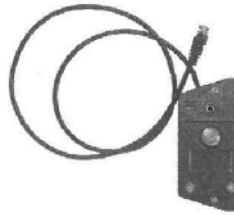

| Symbol fault | Fault | Cause | Remedy |
|--------------|---|--|---|
| | No heat request | Thermostats defective or incorrectly adjusted | Adjust the thermostats, replace if necessary. |
| | Burner does not start after thermostat shutdown. No malfunction indicated on the automatic combustion control unit. | Drop in supply voltage or power failure. Control unit malfunction | Check the cause of the fall in voltage or the power failure. Replace the control unit. |
| | Burner starts at switch-on for very short period and then shuts down and the red LED lights up | The control unit has been intentionally locked | Reset control unit. |
| | Burner starts and then shuts down after pre-ventilation | Flaring during pre-ventilation or pre-ignition | Check ignition sparks/adjust or replace electrode Check/replace fuel-oil solenoid valve |
| | Burner starts and then shuts down after the solenoid valves have opened | No flame signal at end of safety time | Check the oil level in the tank. Top tank up as required. Open the valves. Check the oil pressure and the operation of the pump, coupling, filter, solenoid valve. Check ignition circuit, electrode adjustment. Clean/replace electrodes. Clean/replace flame monitor. |
| | Flame extinguishing during operation | Flame goes out during operating phase | Replace the following items as required: Ignition electrodes/ignition cables/ignition transformer/nozzle/pump/solenoid valve/automatic combustion control unit. |

BLACK SMOKE IS EMITTED FROM THE FLUE TERMINAL.

This indicates bad combustion generally caused by excess fuel or a lack of air.

Check for an obstruction on the burner air inlet.

Change the nozzle.

Check that the burner fan motor is running at full revolutions.

Check that the internal boiler baffle system is not distorted, damaged or sooty.

Remove the boiler internal baffle system and check that the boiler is not contaminated with excess soot, if it is, brush and scrape both of the boiler flue ways and vac the soot out from the bottom of the boiler, making sure that there is no obstruction in the base of the boiler.

GREY SMOKE IS EMITTED FROM THE FLUE TERMINAL.

This situation is caused where the boiler has failed to ignite and several ignition attempts have been made. Where the burner has been flooded with excess unburned fuel, when it eventually lights, dense plumes of light grey smoke will issue from the exhaust as the fuel evaporates off.

If this situation is noticed, turn the boiler off, remove the burner and strip out all the baffles, remove all traces of unburned fuel, replace the baffles.

Re ignite the boiler and keep turning it off every two minutes until the grey smoke clears, in bad cases this process can last for up to 1 hour.

BURNER GOES TO LOCKOUT AFTER INITIALLY FIRING UP FOR A SHORT PERIOD.

The boiler is energised via a live 230vac input from a manual or automatic switching.

The Motor runs and the H.F. spark is discharged across the electrodes.

A few seconds later the fuel is released by the solenoid valve, (note that the fuel release is deliberately delayed and must not occur simultaneously with the spark release.)

At this point Ignition occurs.

The Photocell recognizes ignition has occurred.

The Photocell sends signal to the control unit, which turns the H.F. ignition off and then allows the burner to go into run mode.

The burner will run until it reaches the pre set temperature at which point it will shut down and then modulate in on-off mode until either the auto or manual supply is removed.

If the burner locks out after the flame has been heard to establish this would indicate that the fuel has been released too early and the photo cell and controller have recognised this fault consequently putting the burner into lockout mode.

This situation can be caused by -:

1. A damaged solenoid spindle. (Bent)
2. A faulty solenoid actuator coil.
3. Micro particles of dirt lodged under the solenoid valve causing it not to be able to close, generally known as **let by**. (This situation allows the flame to establish too quickly causing a stray light fault and subsequently locking the burner out.)

BURNER LOCKS OUT AND WILL NOT ATTEMPT TO IGNITE.

Check the mains voltage available. Should be 230vac. Plus or Minus 8%.

BURNER IS COMPLETELY DEAD WITH NO LOCK OUT LIGHT SHOWING.

Check that there is a 230 Volt feed to the appliance.

EXTERNAL CONTROLS FAULTS.

Not covered under this manual.

INVERTER FAULTS.

If a fault develops and the inverter does not output a full sign wave supply, damage will be caused to the Digital Thermowatt burner control box located on the burner.

FLUE AND EXHAUST FAULTS.

The flue should be cleaned and swept every 12 months.

If the boiler is subject to a negative pressure, air can be drawn into the boiler flue system.

A quick check for this situation is to check that air is not being blown out of the burner air inlet, if it is then the air inlet to the burner must be ducted from a suitable vent. Note that if this problem exists either permanently or intermittently it can cause faulty starts and a noisy burner.

VERTICAL BOILER PARTS LIST.

Note that the horizontal boiler has a different flue outlet and a different rear access plate.

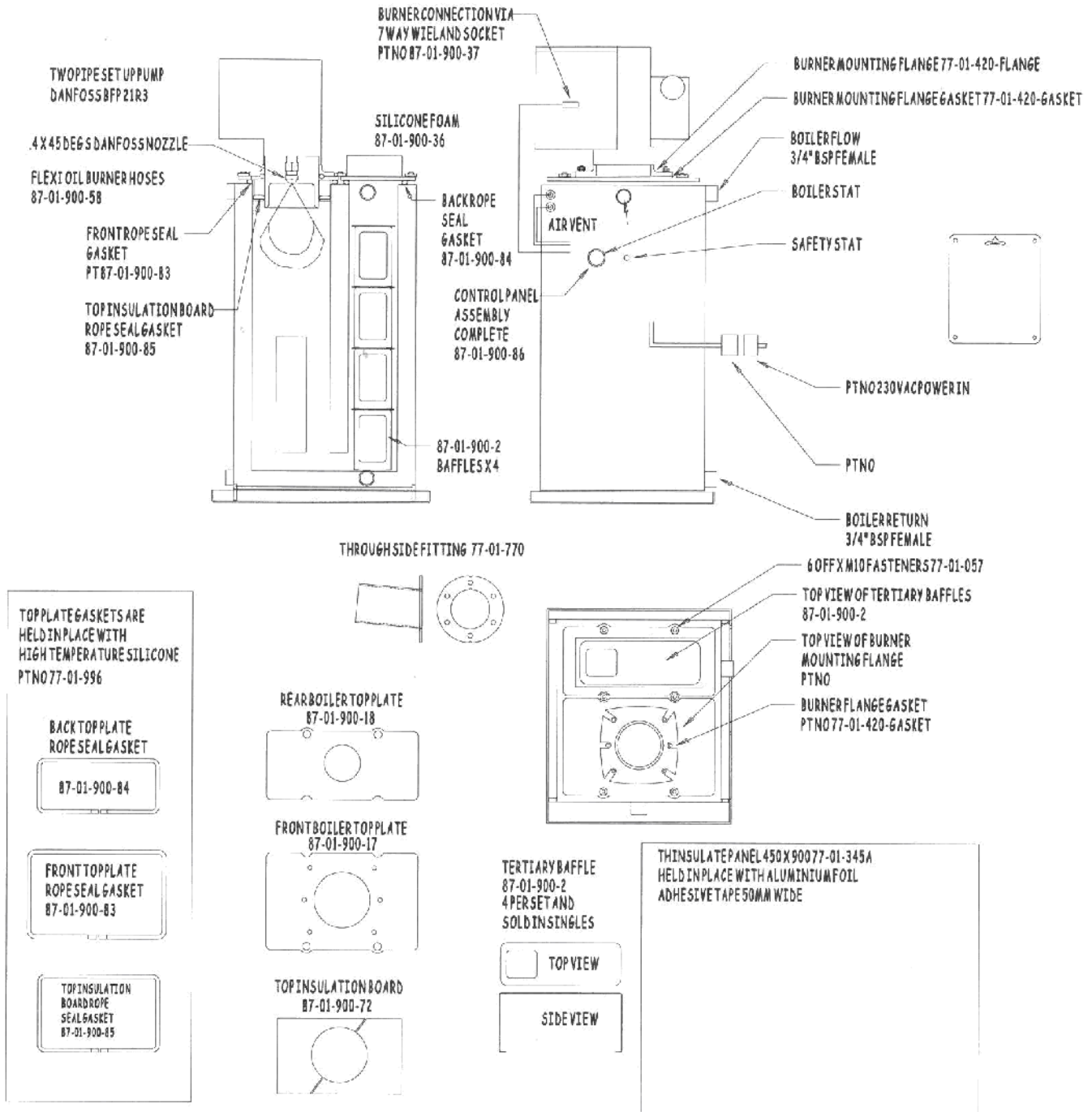

BURNER PARTS LIST.

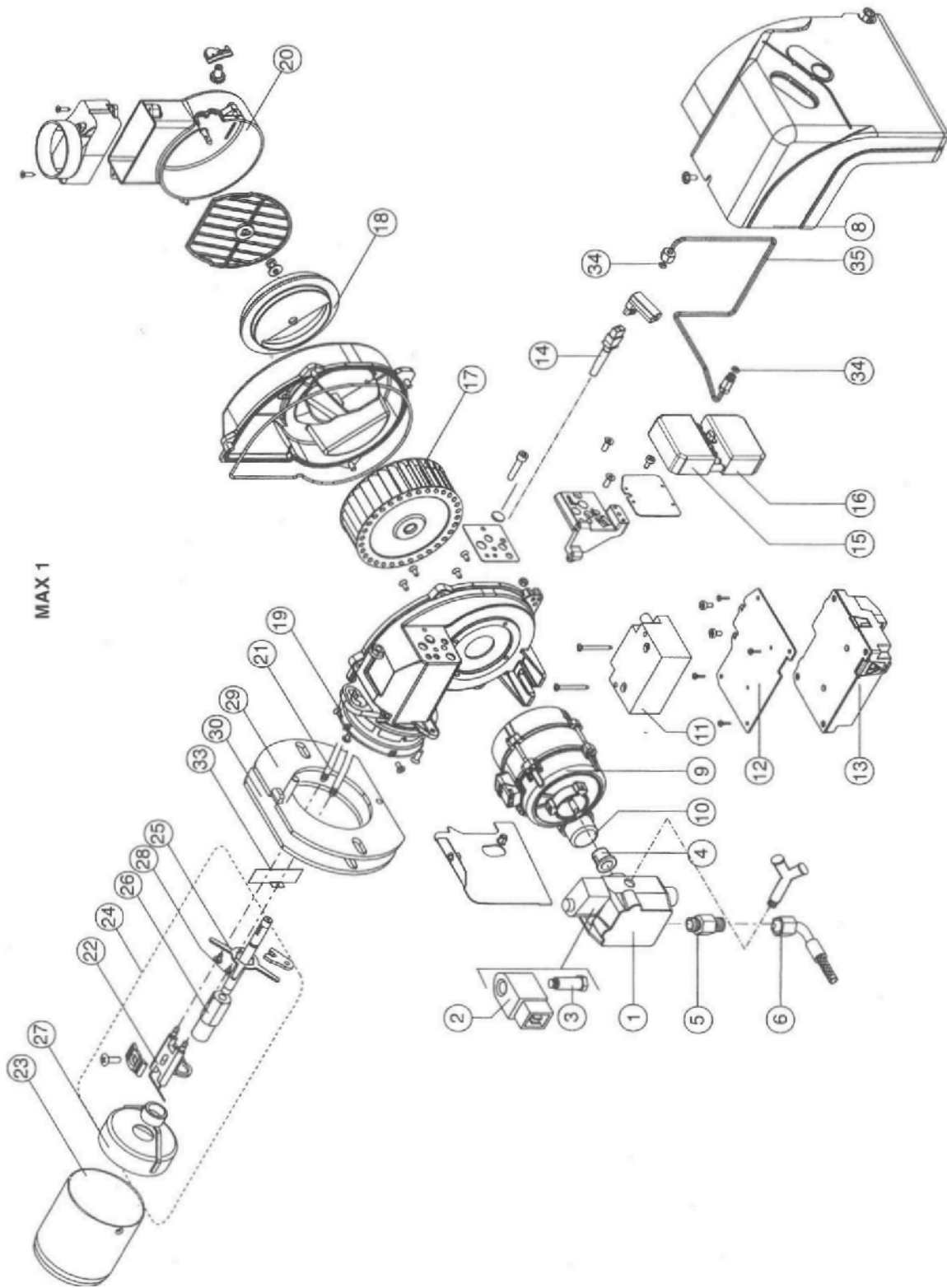

| | | MAX 1 |
|----|--|----------|
| n° | Description | code |
| 1 | OIL PUMP DANFOSS BFP11 R3 071NO143 | 65322967 |
| 2 | COIL DANFOSS | 65323773 |
| 3 | OIL VALVE DANFOSS | 65323751 |
| 4 | COUPLING | 65322920 |
| 5 | NIPPLE | 65321179 |
| 6 | HOSES NW 4X700 | 65323198 |
| 7 | FILTER | - |
| 8 | COVER | 65325528 |
| 9 | MOTOR 75 W AEG | 65322868 |
| 10 | CAPACITOR 3 µF AEG | 65321857 |
| | 5 µF SIMEL | 65325038 |
| 11 | IGNITION TRANSFORMER | 65323257 |
| 12 | SUPPORT | 65325251 |
| 13 | CONTROL BOX WITH CABLES THERMOWATT E-BCU OIL | 65325255 |
| 14 | PHOTORESISTOR SATRONIC | 65320083 |
| 15 | SOCKET WIELAND | 65322070 |
| 16 | PLUG WIELAND | 65322069 |
| 17 | FAN 120 x 42 | 65323826 |
| 18 | AIR DAMPER | 65320519 |
| 19 | ORING | 65321066 |
| 20 | COVER AIR INLET | 65320132 |
| 21 | CABLES TC | 65325252 |
| | TL | 65325253 |
| 22 | ELECTRODES | 65320924 |
| 23 | BLAST TUBE TC | 65320333 |
| | TL | 65320339 |
| 24 | FIRING HEAD TC | 65325400 |
| | TL | 65325401 |
| 25 | NOZZLE HOLDER SUPPORT TC | 65320695 |
| | TL | 65320699 |
| 26 | NOZZLE HOLDER TC | 65320708 |
| | TL | 65320710 |
| 27 | DIFFUSER | 65320760 |
| 28 | ROD TC | 65324056 |
| | TL | 65320204 |
| 29 | FLANGE | 65325174 |
| 30 | GASKET | 65321071 |
| 31 | AIR SELECTOR | - |
| 32 | REAR DISC | - |
| 33 | FAN SCOOP TC | 65320505 |
| | TL | 65320506 |
| 34 | PIPE GASKET | 65321065 |
| 35 | PIPE | 65321508 |

TC = Short Head TL = Long Head
R= Version pre-heater

5. WARRANTY.

Please fill in the warranty form and return it back to the manufacturers for future spares reference purposes.

6. AMENDMENTS.

1. 03-05-13 Nozzle angle changed from 60 degree solid to 45 degree solid.
2. 31-01-15 Upgraded wiring diagram inserted.

© HARWORTH HEATING LTD 30.6.2013

This publication may not be copied by any means, without written permission from the authors.

These products are subject to continuous development and improvement and it is consequently acknowledged that due to this process there may be some omissions and errors.

This publication is intended only to assist the reader in the use of this product and therefore Harworth Heating Ltd shall not be liable for any loss or damage whatsoever arising from the use of any information, error or omission found in this publication.