

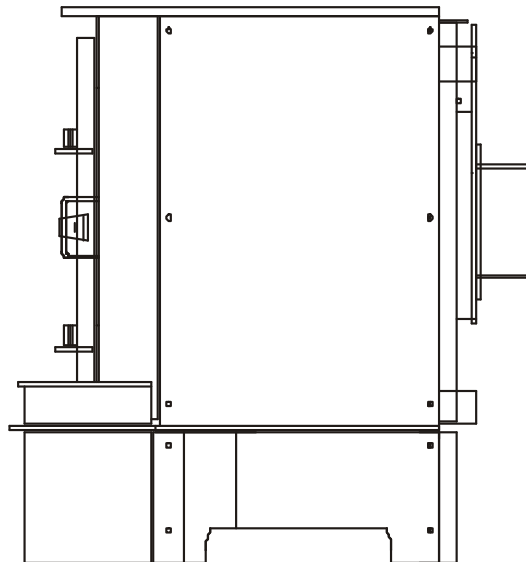

**BUBBLE 3 FRONT CONTROL 15kW
INSTALLER INSTRUCTIONS ISSUE 5@ 24-04-03**

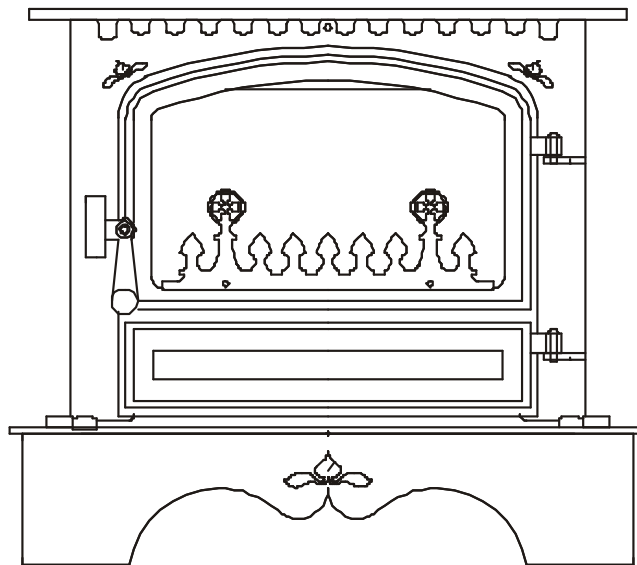

<http://www.oilstoves.co.uk/>

1.0	Health and Safety	5
1.	Control of Substances.	5
2.0	Applicable Regulations	5
1	Building Regulations	5
2	Electrical Regulation	5
3	BS5410 Oil Fired Space Heaters	5
5.	BS5449 Central Heating	5
6.	BS 5601 BS8303	5
7.	BS6461 Pts 1 & 2 1984,	5
8.	BS7566 Parts 1 to 4	5
9.	OFTEC Regulations.	5
3.0	Introduction	5
1.	About the Stove	5
2.	Packing	5
4.	Panel Attachment	5
5.	Oil Valve Covers	5
6.	Front Mounted Controls	5
7.	Service Clearances	5
8.	Flue Options	6
8a.	Existing Chimney Problems	6
9.	Control of Chimney Vacuum	6
10.	Stove Pipe Size	6
11.	Chimney Lining Sizes	6
12.	Boiler Connection Options	6
13.	Burner Details	6
14.	Lighting the Stove	6
15.	Coal Effect Details	6
16.	Spacing from Combustibles	6
17.	Fireguards	6
18.	Warnings	6
20.	Gravity Heat Leak Problems	6
4.0	Materials Required	7
1.	150mm dia chimney liner.	7
2.	Anti down draft terminal.	7
3.	125mm dia flue PIPE.	7
4.	125mm. to 150mm copex adapter.	7
5.	Base of flue closure plate.	7
6.	Oil isolation valve.	7
7.	Remote sensing fire valve.	7
8.	Boiler unions 4 x 1"B.S.P. Male.	7
9.	10mm kutalex copper tube.	7
10.	Wall sleeving 22mm waste pipe.	7
11.	Silicone sealant.	7
12.	Stadium air vent.	7
13.	Vermiculite loose fill.(optional)	7
14.	Cement.	7
15.	Sharp sand.	7
16.	Fire cement.	7

17.	Plugs and screws.	7
18.	Compression fittings.	7
5.0	General Information	7
1.	The Appliance	7
2.	Front Fender	7
3.	Heat shields	7
4.	Coal Effect Kit	7
6.0	Appliance Controls	7
1.	Oil flow control Knob	7
2.	Boiler Thermostat	7
3.	Oil cut off lever.	7
4.	Boiler Safety Stat	7
5.	Oil Control Valve Function	7
6.	Boiler Stat Function.	8
7.	Adjustment of The Operating Stat	8
8.	Adjustment of The Safety Stat	8
9.	Resetting a Flooded Valve	8
7.0	Chimney and Flue Vacuum	8
1.	Vacuum	8
2.	Down Draught	9
3.	Up Draughts	9
3.	Fume leaks	9
4.	Exposed Chimneys	9
5.	Terminal Positions	9
5a.	Terminal Types	9
6.	Cleaning Access	9
7.	Flue pipe Diameter and Specs.	9
8.	Bends in flues and chimneys	9
9.	WARNING	9
10.	Adjustment of the Chimney Vacuum	9
8.0	Oil Feed and Storage	9
1.	Fuel Types	9
2.	Fuel Supply Pipe Work	10
3.	Fuel Oil Storage Tanks	10
4.	Fuel Filter	10
5.	Fire and Isolation Valve	10
6.	Environmental Protection Oil Spillage	10
9.0	Ventilation Requirements	10
1.	Air Supply To The Appliance	10
2.	Air Requirement Calcs.	10
3.	Effects of Extractor Fans	11
4.	Effects of Open Fires	11
5.	Test for Adequacy of air supply	11
6.	WARNING	11
10.0	Water Heating	11
1.	Compliance with British Standards	11
3.	System Requirements	11

4. Gravity Heat Leak Requirement	11
5. Gravity Pipe work	11
6. Space Heating Considerations.	11
7. Check for Leaks	12
11.0 Installation at a Glance	12
1. FIRE - SURROUND	12
2. PREPARE THE OPENING	12
4. LINE THE CHIMNEY.	12
5. FIT VENTILATION.	12
7. RUN THE OIL SUPPLY.	12
8. TEMPORARILY FIT THE APPLIANCE.	12
9. CHECK THE SWINGING DAMPERS.	12
10. LEVEL THE APPLIANCE.	12
11. CONNECT THE PLUMBING	12
12. CONNECT THE CHIMNEY.	12
13. CONNECT THE ELECTRICAL SUPPLY.	12
14. CONNECT THE OIL SUPPLY.	12
15. FILL THE HEATING SYSTEM	13
16. BACKFILL AROUND THE LINER	13
17. FIT ANTI DOWN DRAUGHT COWL	13
18. MAKE UP THE OIL SUPPLY	13
19. REFIT ALL THE INTERNALS	13
12.0 Commissioning	13
7. CHECK FOR OIL LEAKS.	13
8. LIGHTING	13
9. LOW FIRE ADJUSTMENT	14
10. HIGH FIRE ADJUSTMENT	14
11. OPERATING STAT. ADJUSTMENT	15
12. SAFETY STAT. ADJUSTMENT	15
13. EXTINGUISHING	15
14. INSTRUCT THE USER	15
15. FILL IN THE WARRANTY FORM	15
16. ARRANGE SERVICE REGIME	15
13.0 Commissioning Sign off Checks	15
1. Fuel Tank	15
2. Fuel	15
3. Filter	15
4. Site Glass	15
5. Oil line	15
6. Fire valve	15
7. Through Wall Sleeping	15
8. Isolation valve	15
9. Flush Oil Line	15
10. Electrical	15
11. Ventilation	16
12. Water	16
13. Heat Leak Gravity Circuit	16
14. Chimney System	16
15. Clearance from Combustibles	16
16. Check High and Low Fire	16

17.	Check action of barometric dampers.	16
18.	Check controls Function	16
19.	Instruct User	16
20.	Fill in Warranty Card	16
14.0	Fault Finding	16
1.	Racing	16
2.	Flue Vacuum	16
4.	Burner does not light easily	17
5.	Oil Will Not Enter The Pot	17
6.	Stove Goes Out When The Central Heating Pump Is Turned Off.	17
7.	Operating Flow Rates	17
8.	Oil Smells	17
9.	Burner Will Not Modulate	17
15.0	Servicing	17
16.0	Figures	18
	FIG 1	18
	FIG 2 and 3	19
	FIG 4 and 5	19
	FIG 6	20
	FIG 7 and 8	21
	FIG 11 and 12	22

1.0 HEALTH AND SAFETY

1. CONTROL OF SUBSTANCES.

Take great care when handling materials such as insulation boards, glass fibre ropes, ceramic wool, artificial fuel, kerosene and diesel oil, they are all irritants and suitable protective clothing such as disposable gloves dust masks and protective goggles should be worn.

Wash off thoroughly after handling any of these materials.

Carefully dispose of redundant or surplus materials and always vac up after service or installation work.

2.0 APPLICABLE REGULATIONS

The installation of an oil fired BUBBLE © appliance must be carried out by a technically competent person, experienced in the solid fuel and oil fired installation and capable of installing, commissioning and servicing to the current requirements of the relevant local building regulations.

1 BUILDING REGULATIONS

In England and Wales these are J 1-2-3 Provision for introduction of air supply and discharge of products of combustion. Provision for protection against fire and heat.

In Scotland Part F sec 3. In Northern Ireland Part L. In Ireland Part J.

2 ELECTRICAL REGULATION

British IEEE wiring regulations, latest edition.

Codes of practice which apply in the UK are -:

3 BS5410 OIL FIRED SPACE HEATERS

Installation of oil fired space heating and hot water supply Part 1, boilers of rated output not exceeding 44kW

4 BS4543 CHIMNEY SPECIFICATIONS

Specification for chimney for oil fired appliances. Part3.

5. BS5449 CENTRAL HEATING

Central heating for domestic premises Part 1 Forced circulation hot water systems.

6. BS 5601 BS8303

7. BS6461 Pts 1 & 2 1984,

8. BS7566 PARTS 1 TO 4

9. OFTEC REGULATIONS.

OFTEC course OFT101. OFT105.

Failure to comply with the relevant requirements listed above can be hazardous and could lead to prosecution under the law.

If you have any difficulties please phone our sales department on

PHONE 01302 742520. (3 lines.)

FAX 01302 750573

Email sales@oilstoves.co.uk

Web site www.oilstoves.co.uk

3.0 INTRODUCTION

1. ABOUT THE STOVE

The stove is a central heating / room heater which will burn kerosene or diesel in a controlled manner utilizing an open flue to discharge the products of combustion.

2. PACKING

The stove is supplied without the front or side skirts fitted and with all the component parts packed separately for on site assembly.

4. PANEL ATTACHMENT

The side skirts are fastened to the lower front ending plates via the m4 fasteners.

The removable skirt tops are positioned on to the fixed skirts and located via the black rivets supplied in a separate pack.

5. OIL VALVE COVERS

The oil valve control is covered via right and left hand lift of covers, which locate on to the pegs, attached to the right and left hand removable fret tops.

6. FRONT MOUNTED CONTROLS

For safety, maintenance and ease of use all the controls are front mounted.

7. SERVICE CLEARANCES

For future servicing access is required -:

1. For adjustment of the swinging barometric damper at the rear of the appliance.
2. For service of the isolation valve.
3. For service of the fire valve
4. For tightening of any oil feed pipe joints.
5. For tightening of any water connections.

8. FLUE OPTIONS

Stoves must be ordered as either top or rear flue as they are not interchangeable. (25.11.99)

8A. EXISTING CHIMNEY PROBLEMS

Before starting this installation you must make absolutely sure that the chimney does not have a history of down draughting either intermittent or permanent, see figs 11 and 12.

9. CONTROL OF CHIMNEY VACUUM

There are twin barometric dampers at the rear of the stove, which provide an adequate means of adjusting quite high vacuums.

To test the chimney vacuum remove one of the oil valve vent tube and attach your gauge to it.

10. STOVE PIPE SIZE

The outlet adapter on the stove is 125mm dia.

11. CHIMNEY LINING SIZES

Size the lining according to the height of the chimney.

1. On chimneys above 30 feet use 5-inch dia linings
2. On chimneys less than 30 feet use 6-inch dia linings.

12. BOILER CONNECTION OPTIONS

There are 4 x 1" B.S.P.P. adapters at the rear of the stove.

13. BURNER DETAILS

The stoves are designed with a single vaporizing pot having a 15 kW output.

14. LIGHTING THE STOVE

When lighting the stove it is very important that the lighting instructions are carefully followed.

15. COAL EFFECT DETAILS

The stoves are designed to run with or without a coal fire effect kit which when fitted will partially create the effect of a coal fired stove.

It must be clearly understood that coal effect will only be available when the stoves are running at maximum or near maximum performance (as per information given in our sales literature).

16. SPACING FROM COMBUSTIBLES

For spacing from combustibles the following clearances must be observed

Clearance above	18inch or 450 mm
Side Clearance	4inch or 100mm
Rear Clearance	4 inch or 100mm
Front Clearance	4 inch or 100mm

Remember access is required -:

1. For adjustment of the swinging barometric damper at the rear of the appliance.
2. For the isolation valve.
3. For service of the fire valve
4. For tightening of any oil feed pipe joints.
5. For tightening of any water connections.

17. FIREGUARDS

To prevent the risk of injury through burning a fireguard complying with BS6539 must be fitted

18. WARNINGS

The stove must not be operated with the glass front door opened or cracked.

The stove must not be operated without the lighting port plug fitted.

20. GRAVITY HEAT LEAK PROBLEMS

1. During the installation you must pay particular attention to the gravity heat leak requirements of the appliance.

2. On low fire, the appliance will generate 4 kW of continuous output, which must be provided for.

3. YOU MAY WELL HAVE TO MODIFY THE GRAVITY SIDE OF THE SYSTEM TO MAKE EXTRA PROVISION TO ALLOW FOR

ADEQUATE CONTINUOUS DISSIPATION OF THE 4kW.

Make sure that you make provision for carrying out any modifications that may be required.

4.0 MATERIALS REQUIRED

1. **150MM DIA CHIMNEY LINER.**
2. **ANTI DOWN DRAFT TERMINAL.**
3. **125MM DIA FLUE PIPE.**
4. **125MM. TO 150MM COPEX ADAPTER.**
5. **BASE OF FLUE CLOSURE PLATE.**
6. **OIL ISOLATION VALVE.**
7. **REMOTE SENSING FIRE VALVE.**
8. **BOILER UNIONS 4 X 1" B.S.P. MALE.**
9. **10MM KUTALEX COPPER TUBE.**
10. **WALL SLEEVING 22MM WASTE PIPE.**
11. **SILICONE SEALANT.**
12. **STADIUM AIR VENT.**
13. **VERMICULITE LOOSE FILL.(OPTIONAL)**
14. **CEMENT.**
15. **SHARP SAND.**
16. **FIRE CEMENT.**
17. **PLUGS AND SCREWS.**
18. **COMPRESSION FITTINGS.**

5.0 GENERAL INFORMATION

1. THE APPLIANCE

The appliance has a single oil valve situated under the front lower fender, to the left hand side.

The controls to the valve are accessed by removing the small lift off cover at the left hand side of the fender top.

2. FRONT FENDER

The fender also has three removable top panels, which can easily be removed for further access as required.

The front fender is hooked to the stove via two m6 fasteners situated in the angle returns and can be easily lifted away from the appliance after first removing fender tops.

3. HEAT SHIELDS

Behind the fender and the front door are three heat shields, the first is in the centre and behind it are the other two one right and one left.

The heat shields are hooked over M6 cap head screws and are simply lifted for removal to gain access to the lighting port plug.

4. COAL EFFECT KIT

The appliance can be supplied with a coal effect kit, which comprises of artificial coals located on stainless steel coal support bars, the bars are designed to glow bright red in the flame, passing on the incandescence into the coals.

The whole system is designed so that it can be removed in its entirety without the need to disturb the coals making routine cleaning and servicing very easy.

5. WARNING

Do not fit the coal kit until the flame has been correctly adjusted.

6.0 APPLIANCE CONTROLS

The appliance can be controlled via the oil control valve, which is fitted with:-

1. OIL FLOW CONTROL KNOB

Manually operated.

2. BOILER THERMOSTAT

Automatic thermostat with capillary phial and sensing bulb.

3. OIL CUT OFF LEVER.

Manually and automatically operated.

4. BOILER SAFETY STAT

An automatically operated safety shut off thermostat with capillary phial and bulb, which trips the oil flow cut off lever mentioned above.

5. OIL CONTROL VALVE FUNCTION

The valve operates as follows, it has flow control potential from mini to maxi via six graduations and so the appliance can be manually controlled from MINI to MAXI by simply turning the flow control knob (1 above), in addition it also has a water sensing thermostat and an automatic safety oil cut off device should the appliance water temperature

exceed 85 degree C. (this must be set up and tested by the commissioning engineer)

6. BOILER STAT FUNCTION.

The water-sensing thermostat will automatically control the boiler water temperature at whatever setting is required up to a maximum of 80 degree C. and it is operated by a control knob situated alongside the oil flow control knob.

1. If the stove is fired up at full output it will run on full flame until it achieves the target water temperature, set by rotating the stat knob to the desired position, (clockwise to reduce temperature, anti clockwise to increase temperature)
2. The flame then drops to its low fire position, from there on it will automatically modulate the flame from high to low in line with the heating load demand.

7. ADJUSTMENT OF THE OPERATING STAT

Set point of the operating stat can be adjusted as follows.

The thermostat drive knob has a push on cover, which slips over it and grips it acting as an adjustable driver.

The driver has a dead stop which acts against a small brass screw so restricting the rotational movement to one full turn, thus allowing adjustment of water temperature from mini to maxi through one full turn.

If the water temperature settings are not as required remove the plastic push on cover and rotate the aluminium knob anti clockwise until the weight comes off, allow the stove to come up to the required temperature (say 65 deg c) and then rotate the aluminium knob until the fire starts to reduce, refit the push on cover with the scale set as required.

8. ADJUSTMENT OF THE SAFETY STAT

The safety stat can also be adjusted if it does not trip off at the desired temperature of 85 deg C.

To adjust the set point on the safety stat the aluminium top cover of the oil valve has to be removed.

Before removal check to see if the top aluminium cover has a hole punched in it.

If it does the adjusting screw can be accessed through it, if not proceed as follows.

It is held in place by the three slotted screws and the base casting of the thermostat stand.

Undo the three slotted screws and slacken the other two, lift the cover up and work it out from under the aluminium thermostat casting.

When the cover is removed it will reveal the operating bellows of the safety stat, on the left hand end of the bellows is a straight knurled nut, which if screwed in will decrease the temperature set point and if screwed out will increase the temperature set point.

The knurled adjuster screw is very sensitive needs only slight rotational movement

9. RESETTING A FLOODED VALVE

The Oil Controls International oil control valve has a second safety float chamber designed as a safety back up to the first one. It is possible during installation to accidentally flood the second chamber, if this occurs it will not be possible to trip the safety cut off knob as the flooded safety float disarms the trip mechanism. To re establish the action of the safety cut off knob the second float has to be depressed a few times to remove some of the excess oil. This can be done using a small screwdriver; access to the float is obtained by removing the 10mm dia plastic cap pressed into the top of the O.C.V.

7.0 CHIMNEY AND FLUE VACUUM

1. VACUUM

To ensure satisfactory performance from the BUBBLE STOVE hot and cold condition chimneys must be capable of maintaining a constant steady vacuum of not less than .02" W.G. when COLD or more than .07" W.G. when HOT.

The ideal flue vacuum is .03" W.G for low fire and .06" W.G. for high fire.

the stove can be connected to the chimney via a 125mm flue pipe. It is most important that any existing chimney faults such as: -

2. DOWN DRAUGHT

Occasional or permanent down draught (see illustrations)

3. UP DRAUGHTS

Excessive up draughts

3. FUME LEAKS

Regular blockages are established and corrected before any installation work is carried out.

If you are unsure about the condition of the chimney, have it thoroughly cleaned and checked by a suitably qualified person.

4. EXPOSED CHIMNEYS

If the chimney is on an exposed wall, always reline and backfill around the lining with vermiculite to keep it warm and prevent condensation. (Lining dia 150mm)

5. TERMINAL POSITIONS

The chimney should terminate 2 feet above the ridge of the main or highest roof, in compliance with relevant legislation.

5A. TERMINAL TYPES

The chimney must be terminated with a suitable anti down draft cowl such as a VEDETTE or EUROCOWL ETC.

WARNING.

Abnormal chimney terminal locations are very likely to cause problems under certain windy weather conditions.

For details see Figs 11 and 12.

6. CLEANING ACCESS

Provision must be made to allow adequate and easy access into the chimney for cleaning purpose.

7. FLUE PIPE DIAMETER AND SPECS.

The flue pipe from the stove must not be less than 125mm diameter and must comply to one of the following -:

Acid resistant vitreous enamelled flue pipe to BS 1344 Part 2.

Stainless steel to BS1449 Part 2.

Cast iron to BS41.

Mild steel with a wall thickness of 2 mm minimum.

8. BENDS IN FLUES AND CHIMNEYS

Flues and chimneys should always be vertical wherever possible.

On installations where using a bend is unavoidable the maximum allowable bend angle from the vertical is 45 degrees.

45-degree runs should be kept as short as possible (less than 1 metre long) and there should never be more than two bends used.

9. WARNING

Horizontal flue runs are not allowed.

10. ADJUSTMENT OF THE CHIMNEY VACUUM

The flue vacuum can be adjusted by use of the twin, swinging barometric dampers located at the rear of the stove.

The vacuum gauge tube should be attached to one of the oil control valve vent tubes, which vent fume into the front of the combustion chamber.

Lift the tube up and out of the top surface of the oil valve and attach the gauge tube to it.

The counterweights on the swinging dampers can be adjusted in or out to give the required constant steady vacuum of not less than .02" W.G. when COLD or more than .07" W.G. when HOT.

The ideal flue vacuum is .03" W.G for low fire and .06" W.G. for high fire.

To achieve this line chimneys as follows:-

1. On chimneys above 30 feet use 5-inch dia linings

2. On chimneys less than 30 feet use 6-inch dia linings.

The chimney must terminate as per our recommendation; the stove can be connected to the chimney via a 125mm flue pipe.

8.0 OIL FEED AND STORAGE

1. FUEL TYPES

28 Second Commercial Kerosene to BS2869 Part 2: 1988 Class C2 is suitable for use with this appliance.

35-second diesel versions are available to special order.

2. FUEL SUPPLY PIPE WORK

Installation of all oil feed pipe work and storage equipment should be in line with -:

BS5410 Part1

The burner can be supplied with oil via gravity or pumped oil feed system. See FIGS 7 and 8

If a gravity system is used the base of the tank must not be less than half a metre or more than three metres above the burner.

The minimum fuel line diameter is 8 mm but this is dependent upon the length of run.

If other appliances are being supplied from the same oil supply allowance must be made when pipe sizing to ensure that an adequate supply of oil be maintained for each appliance.

The oil line must be sleeved and sealed in a plastic tube where it passes through any brickwork. See FIGS 7 and 8.

Environment protection is of paramount importance, where oil lines are to be buried, special care is needed to ensure that they can't be damaged or cut through.

Trenches must be a minimum of 300mm deep.

Oil lines laid in such trenches should have a substantial cover, strong enough to resist spade impact placed over them. For further advice phone our technical help line.

3. FUEL OIL STORAGE TANKS

Steel oil storage tanks to BS799 Part 5, if there is any doubt consult the tank manufacturer.

OFTEC requirements book T3 July 1995 rev.7.95

Minimum size storage tank should be 300 gals.

Where the tank will be fitted at a lower level than the stove a lift pump must be used with max head above the burner base of 3 metres, the max head of the lift pump over the oil supply tank must not exceed 5 metres.

4. FUEL FILTER

A suitable filter must be fitted.

5. FIRE AND ISOLATION VALVE

A remote acting fire valve such as a Teddington KBB C 150 deg F must be fitted with the phial bulb being mounted under the front fender and the valve being fitted at the point where the fuel line enters the property. See FIGS 7 and 8.

There must also be an isolation valve fitted in the same room as the appliance in a conveniently accessible place. See FIGS 7 and 8.

6. ENVIRONMENTAL PROTECTION OIL SPILLAGE

Environment protection is of paramount importance.

Where properties are prone to be at risk from flooding take great care when fitting oil storage tanks.

Make sure that they are supported on reinforced concrete walls, which are built high enough to keep the tank well above any potential flood level and strong enough to withstand swollen river current or flood tide conditions.

Make sure that the tank is firmly fixed to the supporting walls so as not to be washed away.

Tall, slim line plastic oil tanks must be secured to a substantial base to prevent them from being blown over when they are empty or have low oil content.

9.0 VENTILATION REQUIREMENTS

1. AIR SUPPLY TO THE APPLIANCE

See Building Regulations J1/2/3 section 4. and BS5410 part1.

2. AIR REQUIREMENT CALCS.

Calculate air requirements at 5.5 cm sq per kW of output.

It is most essential that a permanent free air supply be established, as the burner cannot function correctly without it.

Provision for an adequate FREE air supply in to the room and house where the appliance is fitted is required and can be established by multiplying the kW oil input of the appliance by 5.5cm sq.

The air supply will take the form of a purpose designed, NON hit or miss, air vent of correct cross sectional area.

3. EFFECTS OF EXTRACTOR FANS

If an extractor fan is fitted in the same room as the appliance or if there is an open fire in an adjoining room then extra compensatory air must also be made available for these extra requirements.

Minimum extra requirement for extractor fans is 55 sq cm and it is preferred if the extra air supply can be positioned in such a way as it can supply air to the extractor fan without the air stream passing the stove.

4. EFFECTS OF OPEN FIRES

Minimum ventilation requirement for open fires is 212 sq cm

5. TEST FOR ADEQUACY OF AIR SUPPLY

Test for adequacy of air supply is to:-

Set the oil fired appliance going, close all doors and windows in the room, turn on the extractor fan to its maximum capacity, light the open fire and let it get well established,

Test for adequate maintenance of chimney vacuum on the stove, the before and after the extractor fan is turned on, with the open fire going.

During the tests the flue vacuum of the oil-fired stove should be measured to see if there is any noticeable reduction beyond that called for in these instructions.

6. WARNING

Instructions on ventilation must be adhered to.

10.0 WATER HEATING

Bubble stoves are all high water content boilers and as such can easily replace solid fuel installations with the minimum of complication.

An equivalent size for size Bubble stove is capable of giving approximately twice the output of a similar solid fuel appliance over a 24 hr period.

1. COMPLIANCE WITH BRITISH STANDARDS

Before you start to install a water heating Bubble stove remember that the central heating system must comply with BS: 5449 part 1.

If a combined heating and domestic hot water system is to be used, then a double feed indirect hot water storage cylinder to BS: 1556 part 1 should be used.

2. WATER TREATMENT.

In order to prevent the build up of scale and corrosion a suitable inhibitor should be used.

3. SYSTEM REQUIREMENTS

The system must be correctly vented.

The height differential between the header tank and the appliance must not exceed 15.2 metres (50 feet)

Where a common return is used an injector tee must be incorporated into the system to ensure adequate primary circulation when the circulating pump is operating. (See detail in FIG 6)

4. GRAVITY HEAT LEAK REQUIREMENT

The system must incorporate a gravity circuit, which will normally heat the domestic hot water and un-valved radiators with a combined unvalved output of at least equal to the minimum water heating output of the stove, which is a minimum of 4kW.

When the appliance is not connected to a domestic hot water system a gravity system must still be used with the unvalved radiator(s) on the gravity circuit having an output of at least the minimum output of the stove (4kW), this is to prevent boiling in case of pump failure.

5. GRAVITY PIPE WORK

All pipe work in the primary circuit must be 28mm diameter and the gravity flow pipe must rise continuously from the boiler to the open vent. See fig 6.

Connect the heating system to the boiler ensuring that the primary flow pipe rises continuously from the appliance to the vent and make sure that adequate heat leak potential is provided.

6. SPACE HEATING CONSIDERATIONS.

If the appliance is used to heat a small central heating system then the heat output to the room from the fire will be reduced.

7. CHECK FOR LEAKS

Fill the system with water and check for leaks and air locks.

11.0 INSTALLATION AT A GLANCE

Make sure that you are fully aware of the heat leak requirements of the stove read section 3.20

1. FIRE - SURROUND

Before starting to fit the appliance you must take care and make sure that you are aware of the following important points.

WARNING

Take great care when using marble hearths or slips, although they may be classed as non combustible they are prone to cracking with the effects of either radiated or convected heat, always carefully consult the fireplace or marble supplier for advice on this matter.

2. PREPARE THE OPENING

Prepare the opening and hearth.

4. LINE THE CHIMNEY.

5. FIT VENTILATION.

7. RUN THE OIL SUPPLY.

Side or alternatively rear access is provided for oil line entry.

For rear entry lines use 2 x 22mm conduit pipes, one for the oil line and one for the KBB bulb, remember that the KBB may well need in service replacement and an allowance must be made for this to be easily carried out, should the need arise.

Install fuel tank in line with our instructions and run a fuel line up to the rear right hand side of the appliance, before fitting the appliance into the hearth it will be advisable to pipe up the oil feed to the valve to make connection of the oil feed to the appliance easier

Fit the remote fire valve phial under the lower fender, if it is located in a position where the temperature can exceed 150 deg F, it will trip and need to be reset on the fire valve body.

Fit the isolation valve see figs 7 and 8.

Flexible Hoses are not allowed for connections to vaporizing pot burner

8. TEMPORARILY FIT THE APPLIANCE.

1. Before attempting to fit the appliance make sure that it has not suffered any damage in transit particularly around the oil control valve area, you must ensure that when fitted it is levelled in such a way as to ensure that when oil runs into the pot it must always run slightly towards the bottom of the lighting port

To achieve this it may be necessary to pack up the back of the appliance, spill a small amount of fuel into the pot to check that it runs to the front of each pot.

If this is not done it will not be possible to light the stove in line with our instructions.

Undo the door.

3. Fit the lighting port plug.

4. Check that the heat shields are correctly fitted.

Take great care with hands inside the pot there may be some sharp edges.

5. Remove all the burner components, through the front door opening as follows -:

COAL KIT

CATALYSER AND RING

9. CHECK THE SWINGING DAMPERS.

Located in the rear of the stove, check that they are swinging freely and closing properly.

10. LEVEL THE APPLIANCE.

In the directions adjusting the level to make sure that the oil runs very slightly towards the bottom of the lighting tube. **(Pack up the back of the stove if required)**

11. CONNECT THE PLUMBING

12. CONNECT THE CHIMNEY.

13. CONNECT THE ELECTRICAL SUPPLY.

14. CONNECT THE OIL SUPPLY.

Make up the oil feed connection into the oil control valve, take care to make an accurate job of the pipe work so as not to transfer any undue pressure on to the valve.

The stove leaves the factory with the oil control valve correctly adjusted on the O.C.V. bracket clamping bolts.

Using a small spirit level, check the level of the Oil Control Valve; it should be made level in the directions before any adjustments are carried out.

15. FILL THE HEATING SYSTEM

Check for leaks.

16. BACKFILL AROUND THE LINER

If the flue is exposed backfill around it with loose fill vermiculite.

17. FIT ANTI DOWN DRAUGHT COWL

18. MAKE UP THE OIL SUPPLY

Purge the line and make sure that there are no leaks.

19. REFIT ALL THE INTERNALS

Except the coal kit and externals of the appliance.

Top flue stoves have a single internal baffle plate which slides over the top of the boiler cross tubes, back flue stoves do not have the top plate fitted but have two small circular baffle plates with legs which push into the two outlet tubes, they can be pushed in or pulled out to compensate for differing flue vacuum.

12.0 COMMISSIONING

NOTE

1. If during the lighting stage, excess oil is allowed to build up in the pot, the burner will race and generate quite loud audible vibrations, if this occurs don't panic, turn the oil off on the pot, and wait a few minutes until the burner flames reduce in size and eventually go out.

2. If the flame is allowed to get too large during the lighting stage, it is possible to damage or break the glass door panels.

3. Before lighting and adjusting the pot make sure that the coal effect kit has been removed, this will allow you to see the flame and the effects of any adjustments much better.

4. (Refit the coal effect kit after the flame has been correctly adjusted and then fine-tune the flow rates to achieve the desired effect)

5. Turn on the oil at the isolation valve and press the oil safety cut off lever on the oil control valve down to trip the oil on via an audible click.

6. Make sure that the stat is calling.

7. CHECK FOR OIL LEAKS.

1. Check that oil does not leak from the pot, valve, descaling device or pipe work.

8. LIGHTING

1. If there are no leaks proceed as follows -:

2. Turn the oil flow off.

3. Empty the pot of all oil.

4. Open the door and remove the front heat shield (lift off the two cap head allen screws)

8. Remove the lighting port plug and impale a small piece of fire lighter onto the spike.

9. Turn the oil on to the first position via the flow control knob and when oil can be seen to trickle into the pot turn it off so as not to allow an excessive build up.

10. Make sure that the oil is running towards the bottom of the lighting port tube,

11. (It should gather in a small pool, at the bottom of the lighting port tube, no bigger than a small biscuit.)

12. If it does not do this, pack the back of the stove up until it does.

13. Remember that there is a skill involved when lighting oil stoves, you must make sure that the pot stays alight during the lighting process and you must also carefully control the flow and build up of oil in the pot.

If there is a decent chimney vacuum as soon as the door on the stove is closed oxygen in air will be drawn into the pot to keep it alight, if there is no or very little chimney vacuum there is a possibility that the burner could rapidly go out by consumption of available oxygen in the pot and consequently extinguish itself.

14. If this occurs turn the oil off to the pot and start again after the pot has cooled down.

DO NOT ATTEMPT TO RE LIGHT A HOT STOVE.

15. Therefore the skill is -:

Make sure that there is a chimney vacuum.

Make sure that the oil is in the right place.

Make sure that there is not too much oil in the pot.

1. Turn the oil on to the first position via the flow control knob and when oil can be seen to trickle into the pot turn it off so as not to allow an excessive build up.

2. Make sure that the oil is running towards the bottom of the lighting port tube.

It should gather in a small pool, at the bottom of the lighting port tubes, no bigger than a small biscuit.

3. When the oil has formed the small pool, turn the oil **off**.

4. Fit a small piece of firelighter on to the lighting port plug spike, light it and push it down into the oil at the bottom of the lighting port tubes making sure that it drops into the oil.

5 Close the front door.

6. Look inside the pot and watch for signs of flames or burning, you should be able to see a small yellow flame in bottom of the pot.

7. When you are sure that the pot is alight, turn the fuel flow on again at the lowest setting for 30 seconds and turn it off again.

8. Allow another 30 seconds to elapse and when you are sure that the pot is alight turn the oil **on** to the pot and let the flame establish on low fire.

9. When the pot is running on low fire gradually turn the oil flow up to setting 3 and let the chimney warm up.

10. When the pot is running on setting 3 and the chimney has warmed up adjust the chimney vacuum via the counterweights on the dampers and make sure that it is set to a maximum of .07" W.G.

12. Always start by setting the low fire first.

9. LOW FIRE ADJUSTMENT

When the burner has been running for five minutes on position 1 LOW FIRE the lower

catalyser will be glowing dull red, with blue flame hovering above the catalyser, if this is not the case adjust the low fire screw accordingly.

Note the flue vacuum will effect the low fire settings.

The ideal flue vacuum is .03" W.G for low fire and .06" W.G. for high fire.

If the flue vacuum is excessive on low fire it will not be possible to run the stove at its low fire flow rate of between 7 and 8 cc's per minute.

10. HIGH FIRE ADJUSTMENT

When you are happy with the low fire running turn the burner slowly and progressively up to full fire, this should produce a conical wispy blue flame with just the odd touch of yellow. If there is excessive yellow reduce the high fire accordingly.

2. When you are happy with this procedure, turn the stove on to low fire and open the door and refit the coal kit.

3. Don't leave the door open for very long as this will cause excess fuel to build up in the pot, when you close the door the stove will flair up slightly until it re establishes equilibrium, recheck the flame picture allowing adequate time for the coals to get going (10 minutes)

4. On full output, after approximately ten minutes, the coals should begin to glow red and there should be wispy blue flames licking through them, to get the maximum effect the stove will need to be left for half an hour or so, if there are yellow flames reduce the high fire adjuster screw by quarter turn increments, allowing one minute for the burner to stabilize after each quarter turn adjustment.

5. When correctly adjusted, on maximum setting, the effect should be bright incandescence with wispy blue flames penetrating through the coals.

6. Excess oil flow, incorrect flue vacuum, and bad coal positioning will cause rapid sooting of the glass and coals.

The ideal flue vacuum is .03" W.G for low fire and .06" W.G. for high fire.

If the flue vacuum is low on high fire it will not be possible to run the stove at its high fire flow rate of 27 cc's per minute.

7. When you are happy with the flame picture on high and low fire you must then check the action of the APPLIANCE TEMPERATURE CONTROL mechanism

Check the appliance controls are working correctly

See section on -:

11. OPERATING STAT. ADJUSTMENT

12. SAFETY STAT. ADJUSTMENT

Make sure that the valve does not shut down when the appliance is working under the control of the boiler stat on gravity flow without the pump running.

NEVER TRY TO RELIGHT A HOT URNER.

MAKE SURE THAT THE BURNER IS COMPLETELY COOLED DOWN BEFORE RE LIGHTING.

13. EXTINGUISHING

Turn the oil flow control knob fully off.

After a few minutes, the flames will die down and eventually go out.

14. INSTRUCT THE USER

1. LIGHTING PROCEDURE

2. POSITION OF ALL OIL CUT OFF SAFETY DEVICES

3. ON THE PRINCIPLES OF CONTROL AND THE IMPORTANCE OF ADEQUATE HEAT LEAK REQUIREMENT.

4. THE IMPORTANCE OF REGULAR MAINTENANCE.

15. FILL IN THE WARRANTY FORM

The warranty covers PARTS ONLY for a period of ONE YEAR and is conditional upon all the requirements of our installation instructions being fully adhered to.

Labour, travelling or consequential loss or damage is not covered.

16. ARRANGE SERVICE REGIME

6 monthly.

NOTE-:

Once the installation is completed it should be inspected to make sure that the work is of a satisfactory standard.

13.0 COMMISSIONING SIGN OFF CHECKS

Commissioning should not be signed off unless the commissioning engineer is satisfied that all the work done complies with the relative standards and regulations detailed within this document.

Checks should be carried out on the following-:

1. FUEL TANK

Check for leaks-stability-height-position-vent.

2. FUEL

Fuel- check for correct grade

3. FILTER

Is it fitted?

Check for function and leaks.

4. SITE GLASS

Check for function and leaks

5. OIL LINE

Check for function, positioning, material suitability and leaks.

6. FIRE VALVE

Check for function and leaks.

7. THROUGH WALL SLEEPING

Check that it is fitted and sealed

8. ISOLATION VALVE

Check for function, convenience of positioning and leaks.

9. FLUSH OIL LINE

5 litres of oil through the line to check for contamination and to clear the oil line of installation debris and trapped air.

10. ELECTRICAL

Check for correct fusing, location and specification of any isolation devices.

11. VENTILATION

Make sure that ventilation is provided in line with O.F.T.E.C requirements.

12. WATER

The system should be pre-checked for leaks, satisfactory functioning and safety of all or any control devices.

13. HEAT LEAK GRAVITY CIRCUIT

Make sure that the heat leak circuit is adequate and unvalved. (This means that it must be equal to the minimum low fire output of the stove, which can be calculated by using the minimum flow rate of the appliance.

The valve flow rates are printed on the oil control valve aluminium cover plate.

All stove flow rates are stated on our price lists. To help with calculation there are 35,000 BTU's per litre (1000cc's) of oil and the appliance will be running at 80% efficiency.

14. CHIMNEY SYSTEM

Chimney system should be checked to make sure that it complies with the relative standards, regulations and all other instructions given.

15. CLEARANCE FROM COMBUSTIBLES

Check the appliance is fitted with adequate clearances from combustibles.

16. CHECK HIGH AND LOW FIRE

17. CHECK ACTION OF BAROMETRIC DAMPERS.

18. CHECK CONTROLS FUNCTION

Check correct hot condition functioning of water heating system and all controls.

19. INSTRUCT USER

Ensure that the customer is instructed on the basic use of the appliance, timers, controls and oil / electrical isolation devices if fitted.

20. FILL IN WARRANTY CARD

Ensure that the warranty registration documentation is returned to Harworth Heating Ltd.

14.0 FAULT FINDING

1. RACING

1. Audible vibrations generated by the flame caused by too much oil in the pot.

2. Turn off the oil flow until the burner has settled down to a steady burn rate and then turn the fuel on again but don't let the flame go out otherwise the burner MUST be allowed to cool down fully before a reignition is attempted.

2. FLUE VACUUM

1. The pot type burner is extremely sensitive to flue vacuum variations.

2. Good combustion will not be possible unless our instructions on chimneys and flue vacuum are followed.

3. If the burner does not burn with a blue flame, recheck the chimney vacuum and oil flow rate.

4. If the burner do not run well check that the seals in the stove are good and that there is no ingress of air into the appliance flue ways.

5. Check that the swinging dampers are not jammed open.

6. Check that the correct fuel oil is being used.

7. Check the levels of the oil valve to pot,

3. BURNER RUNS SOOTY.

If the problem has just started it may be

a. The fuel,

b. An unusual wind condition,

c. Dampers jammed or stuck open,

d. Obstruction in the chimney causing a loss of vacuum.

e. Burner to closure plate seal U.S.

f. Door not sealing.

g. Damaged door glass.

h. Burner carboned up.

j. Carbon deposits in the oil inlet pipe.

(Remove the feed pipe between the pot and the oil valve and clean it out.)

k. Excessive fuel flow on high fire

L. Inadequate fuel flow on low fire.

m. Inadequate air for blue flame combustion.

2. Check that the chimney is correctly lined and backfilled with vermiculite, particularly important on exposed gable end chimneys.

3. Check that the fuel is the correct type and quality.

4. Check that the flow rates are correct.

4a. Check the flue vacuum and all these potential problems, before carrying out any adjustments to the flow rates.

5. Where burner is run at high fuel flow rates on low chimney vacuums, long unsatisfactory yellow flame combustion and bad sooting will occur.

6. To rectify this problem reduce the high fire flow rate screw on the Oil Control Valve until blue flame combustion occurs.

7. Never switch from low settings to high settings, a longer burner life will be achieved if the regulator is moved only by one number at a time leaving approx one minute between each setting change.

4. BURNER DOES NOT LIGHT EASILY

1. Check the level of the bottom of the pot and make sure that the stove is levelled so that the oil flows very slightly towards the bottom of the lighting port tube.

2. Check the chimney vacuum cold.

3. Check that all the seals in the stove are sound.

4. Check that the swinging dampers are not jammed open.

5. Check that oil is flowing freely into the pot.

5. OIL WILL NOT ENTER THE POT

1. Check that the safety cut out lever has not been accidentally shut off.

1a. Check that the isolation valve has not been turned off.

1b. Check that the fire valve has not tripped off.

1c. Check that there is oil in the main tank

2. If it is not possible to reset the safety cut out lever phone us for advice. In case of failure of the first float the second one catches the excess oil and trips the safety cut out lever, making it impossible to reset.

3. Simulated failure can occur if a full oil control valve is disturbed causing the secondary float chamber to flood.

4. Disconnect the outlet from the valve and check for oil flow.

5. Disconnect the inlet to the descaling device and check for oil flow.

6. Remove the descaling spindle and check for obstructions

6. STOVE GOES OUT WHEN THE CENTRAL HEATING PUMP IS TURNED OFF.

1. Generally this is caused by the high stat bellows, shutting off the oil trip in the valve.

2. To check this out feel the trip lever to see if it has tripped off.

It can be caused by one of the following

a. The flow to the heat leak is inadequate.

b. The size of the heat leak is inadequate.

c. The safety stat set point needs increasing.

7. OPERATING FLOW RATES

Flow rates are shown in cc per minute.

	Min	max
B3x15kW	8cc	26cc

To achieve optimum burner performance at the stated flow rate, you will need to have a matching flue vacuum as stated.

If the chimney does not generate enough vacuum the flow rate will have to be adjusted so that the burner maintains equilibrium, i.e. blue flame combustion.

This will result in lower output from the appliance.

8. OIL SMELLS

Carry out a visual check on all joints for obvious leaks.

Check that the descaling lever packing gland nut is adjusted.

9. BURNER WILL NOT MODULATE

The thermostats situated on the oil control valve control the burner.

The action of the stats is detailed in section 4-0-4b and the thermostat phial bulbs and capillaries are illustrated in fig. 5.

15.0 SERVICING

Servicing should be carried out at six monthly intervals.

Service engineers should request a copy of the servicing schedule from our sales desk.

Schedules will also be available from our web site <http://www.bubble-stoves.co.uk>

16.0 FIGURES

Additional information follows in the form of illustrations.

© HARWORTH HEATING LTD 30.6.98

This publication may not be copied by any means, without written permission from the authors.

This product is subject to continuous development and improvement and it is consequently acknowledged that due to this process there may be some omissions and errors.

This publication is intended only to assist the reader in the use of this product and therefore Harworth Heating Ltd shall not be liable for any loss or damage whatsoever arising from the use of any information, error or omission found in this guide.

Only approved personnel, WHO HAVE BEEN SUITABLY TRAINED, must carry out maintenance on this product.

FIG 1

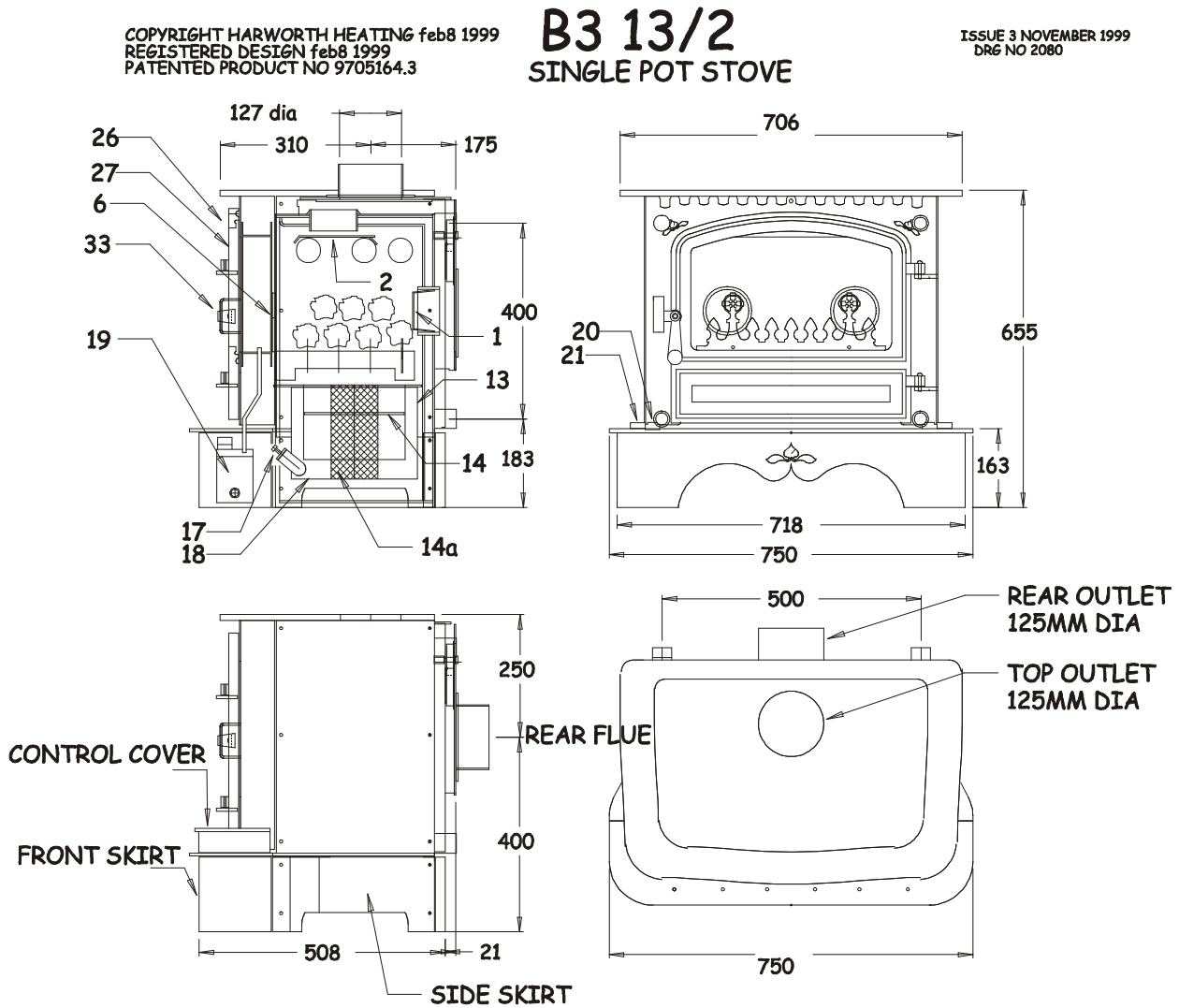

FIG 2 AND 3

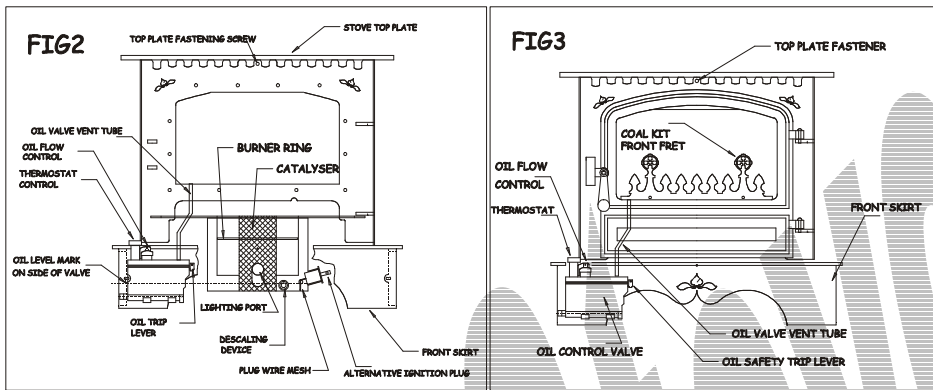

FIG 4 AND 5

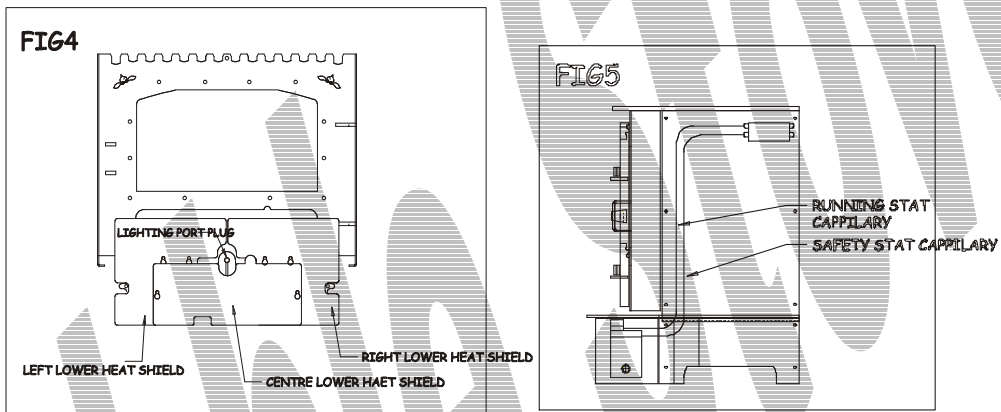

FIG 6

Typical Plumbing Installation

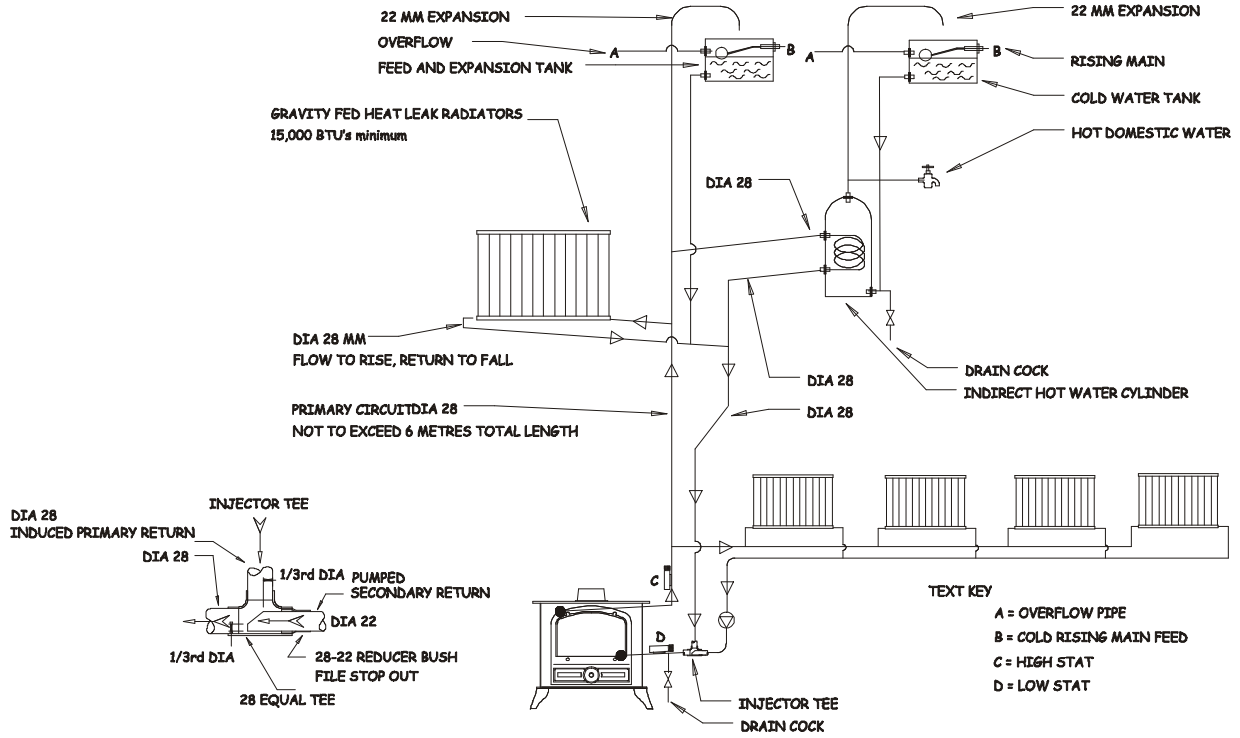

FIG 7 AND 8

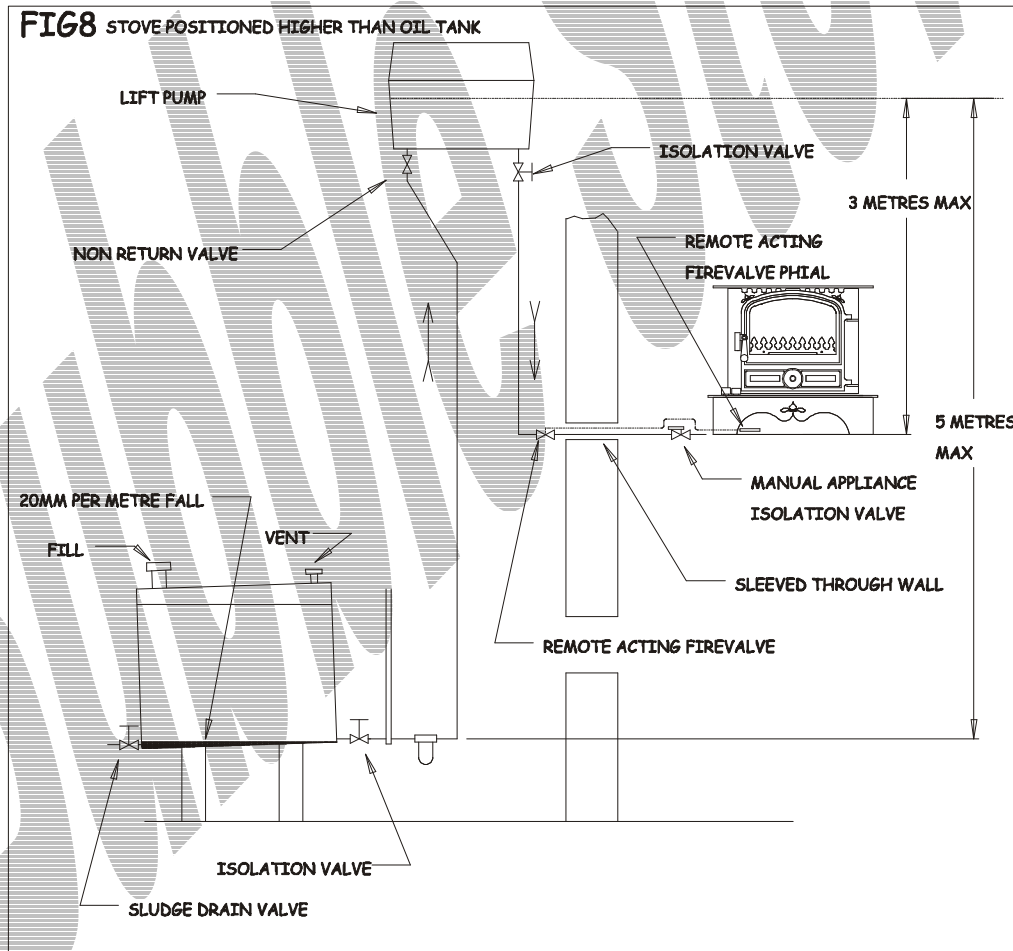
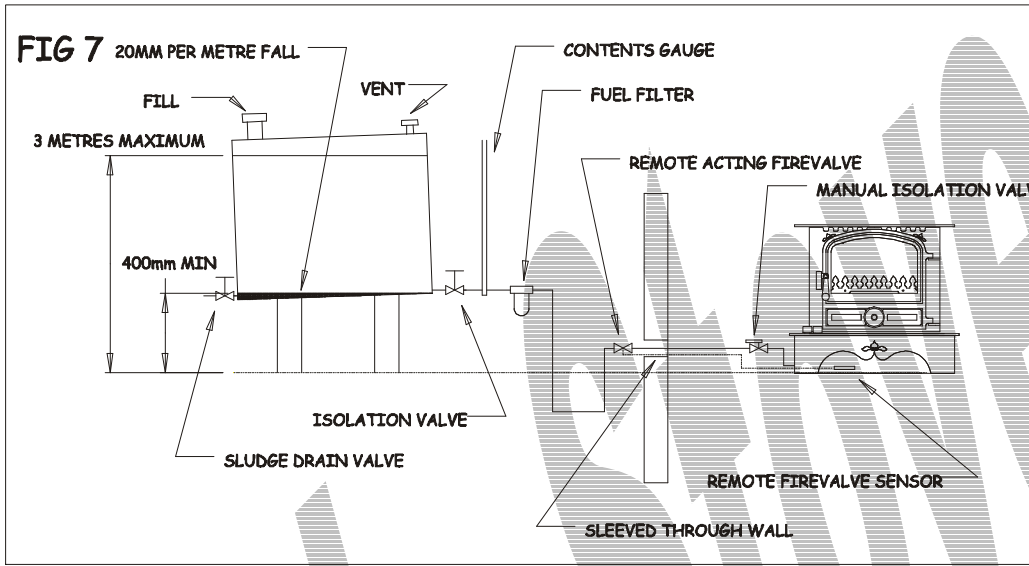

FIG 11 AND 12

