

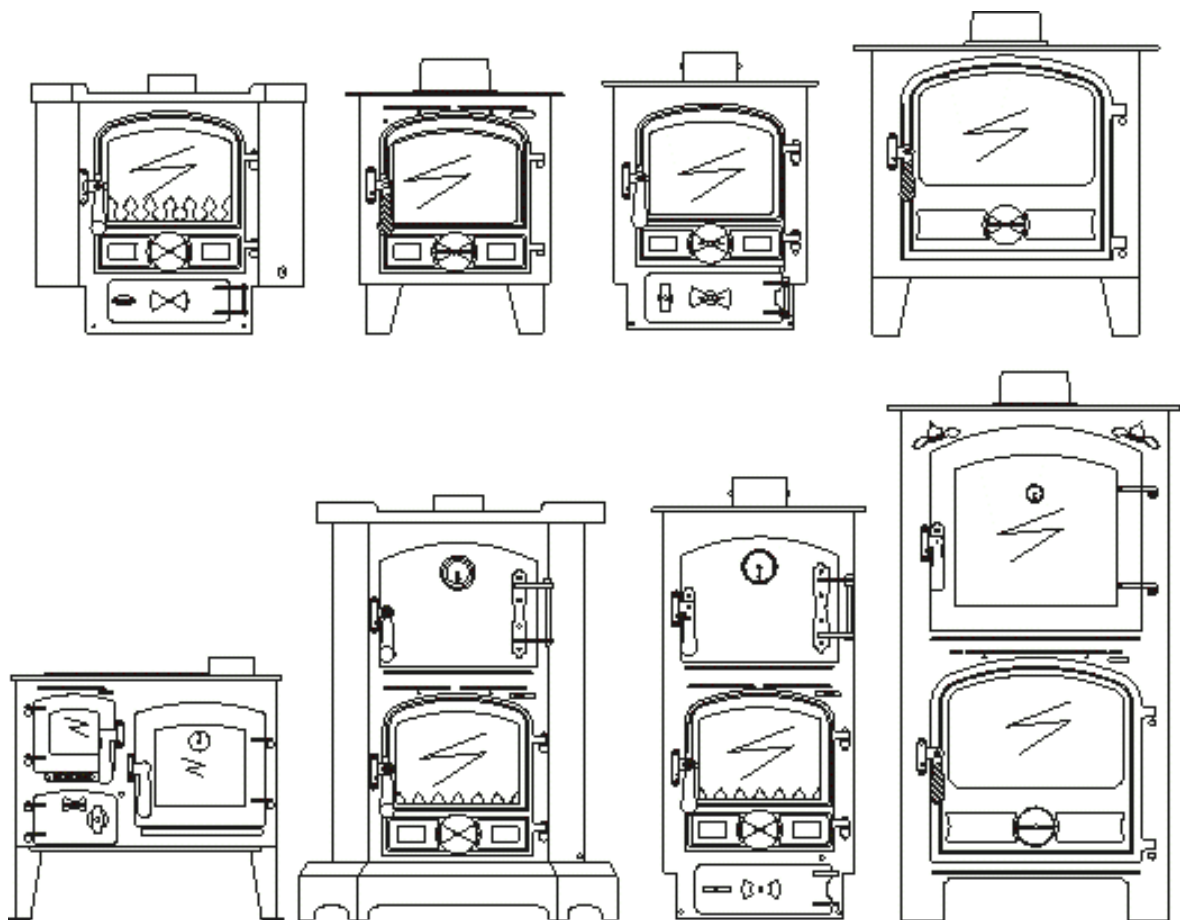

WOOD AND SOLID FUEL OVEN STOVES MARINE INSTALLER INSTRUCTIONS

ISSUE 18-02-15



Index

Health, Safety and Warnings.	3
Rules and Regulations.	4
C O Alarms.	4
Specifications.	5
Table 1	5
Dimensions Stoves.	6
3B Corner Multifuel Stove Fig 1	6
4B Multifuel Stove Fig 1	6
3B WOOD Stove Fig 1	7
7B WOOD Stove Fig 1	8
Dimensions Oven Stoves	9
3B Corner Multifuel Pod Fig 1	9
4B Multifuel Pod Fig 1	9
7B Wood Pod Fig 1	10
Pie Pod Mini, Back cabin Cooker	10
Hearth and Fireplace Requirements	10
Fig 2 Rectangular Appliances and Cookers Hearth Size Requirements	11
Distances From Combustible Materials	11
Fig 3 Corner Appliance Distance from combustibles	13
Chimney Systems.	13
Fig 4 General Layout of Typical Flue.	14
Fig 5 General Layout of MK3 Deck Flange Assembly.	15
Connection to Flues.	16
Ventilation.	16
Commissioning Dry Stoves.	17
Pre Firing Checks.	17
Post Firing Checks (Dry Stoves.)	17
Instruct The User (Dry Stoves.)	17
Warranty.	17
Commissioning Wet Stoves.	17
Instruct The User (Dry Stoves.)	18
Guarantee	18
How to proceed with a complaint.	18
Glossary Of Terms.	19
Bibliography	19
Specification	19

HEALTH, SAFETY AND WARNINGS.

Take great care when handling materials such as insulation boards, glass fibre ropes, ceramic wool, paints and silicones, they are all irritants and suitable protective clothing such as disposable gloves, dust masks and protective goggles must be worn. Wash off thoroughly after handling any of these materials.

Fire cement is caustic and must not come into contact with the skin, protective gloves and goggles must be worn, after use, wash hands thoroughly with plenty of water.

Carefully dispose of redundant or surplus materials and always vac up after installation or service work has been carried out.

There is no asbestos used in the manufacture of this product but where the installer is replacing an older heating appliance take great care. Asbestos was commonly used in sealing ropes, insulation and gasket materials if there is any possibility of disturbing old asbestos in the course of installation seek specialist guidance and use appropriate equipment, always damp down, always wear a breathing mask and always carefully vac up.

Take care when installing or servicing this product to avoid personal injury, all works must be carried out with care to meet the requirements of Health and Safety and comply with the Health and Safety rules and any new regulations introduced during the lifetime of these instructions.

Particular attention should be drawn to:-

The weight of the appliance detailed in Table 1.

Suitably adequate equipment must be available for loading, unloading and on site appliance movement.

Fireguard.

A suitable fire guard conforming to BS8423:2002 should be used with all Bubble solid fuel appliances.

Correct use of the appliance.

The appliance should not be used with the fire door open and where applicable the ashpit door open. These doors must be kept closed at all times except when re-fuelling or de-ashing.

The appliance is capable of intermittent operation.

Extractor fans.

Do not fit an extractor fan in the same room as the appliance as this can cause fumes to be drawn from the stove into the room.

Inflammable materials.

Do not use or store aerosols, sprays or any other flammable materials near to the appliance when it is in use.

Flues.

The appliance must not be connected to a shared flue.

Identification.

A serial number plate is fastened to the appliance and printed on the warranty document displaying information about the product.

When ordering consumables and spare parts it will be necessary to quote the serial number.

Consequential loss.

The manufacturer will not be responsible for any consequential or incidental loss or injury however caused.

RULES AND REGULATIONS.

When fitting a new or replacement, wood or solid fuel heating appliance, you are required by law to obtain Building Control Approval from your local authority OR the work must be carried out through a government approved, competent persons scheme such as that operated by HETAS who can be contacted on 0845 634 5626 www.hetas.co.uk.

In addition to these instructions the requirements of BS 8303 and BS EN 15287-1:2007 must be fulfilled.

A faulty installation can cause life threatening danger to the property and its occupants therefore it is very important to understand the requirements of the national Building Regulations and standards, along with any local regulations and good working practices that may apply.

Should any differences between these instructions and the Building Regulations then the Building Regulations must apply.

Your local Building Control Office can advise regarding the requirements of the regulations.

CO ALARMS.

The following alarm must be fitted in the same room as the appliance.

Carbon Monoxide Alarm to BS EN50291:2002

It is also advisable to fit an Optical Smoke Alarm to BS EN14604

SPECIFICATIONS.

TABLE 1

The following table shows the approximate outputs of each appliance based on a 45 minute re-fuelling cycle burning seasoned hardwood logs.

Note that the minimum chimney vacuum will allow the fire to be started, for full output use, the chimney vacuum will need to be at the max reading.

STOVES	WATER	SPACE	HEIGHT	WIDTH	DEPTH	FLUE DIA	FLUE OPTIONS	INS FLUE VACUUM	WEIGHT kg
CORNER		1-4KW	514	545	305	100	TOP ONLY	.03"MIN TO .08"MAX	50
WET VERSION	1-3KW	1-2KW	514	545	305	100	TOP ONLY	.03"MIN TO .08"MAX	60
4B		1-5KW	495	442	317	100	TOP-REAR	.03"MIN TO .08"MAX	60
WET VERSION	1-3KW	1-2KW	495	442	317	100	TOP-REAR	.03"MIN TO .08"MAX	70
3B		1-3KW	486	440	317	125	TOP-REAR	.03"MIN TO .08"MAX	50
WET VERSION	1-2KW	1KW	486	440	317	125	TOP-REAR	.03"MIN TO .08"MAX	50
7B		2-8KW	590	595	342	125	TOP-REAR	.1"MAX .03"MIN TO	80
SMALL BOILER	1-3KW	1-4KW	590	595	342	125	TOP-REAR	.1"MAX .03"MIN TO	90
LARGE BOILER	2-8KW	1-3KW	590	595	342	125	TOP-REAR	.1"MAX .03"MIN TO	120
OVEN STOVES									
CORNER POD		1-4KW	817	545	305	100	TOP ONLY	.03"MIN TO .08"MAX	90
WET VERSION	1-3KW	1-2KW	817	545	305	100	TOP ONLY	.03"MIN TO .08"MAX	105
4BPOD		1-5KW	850	442	317	100	TOP ONLY	.03"MIN TO .08"MAX	100
WET VERSION	1-2KW	1-3KW	850	442	317	100	TOP ONLY	.03"MIN TO .08"MAX	115
7BPOD		2-8KW	1050	595	480	125	TOP-REAR	.1"MAX .03"MIN TO	130
SMALL BOILER	1-3KW	1-4KW	1050	595	480	125	TOP-REAR	.1"MAX .03"MIN TO	140
LARGE BOILER	2-8KW	1-3KW	1050	595	480	125	TOP-REAR	.1"MAX .03"MIN TO	150
MINI COOKER		1-3KW	500	550	385	100	TOP ONLY	.08"MAX .03"MIN TO	120
WET VERSION	1KW	1-2KW	500	550	385	100	TOP ONLY	.08"MAX .03"MIN TO	125

DIMENSIONS STOVES.

3B CORNER MULTIFUEL STOVE FIG 1

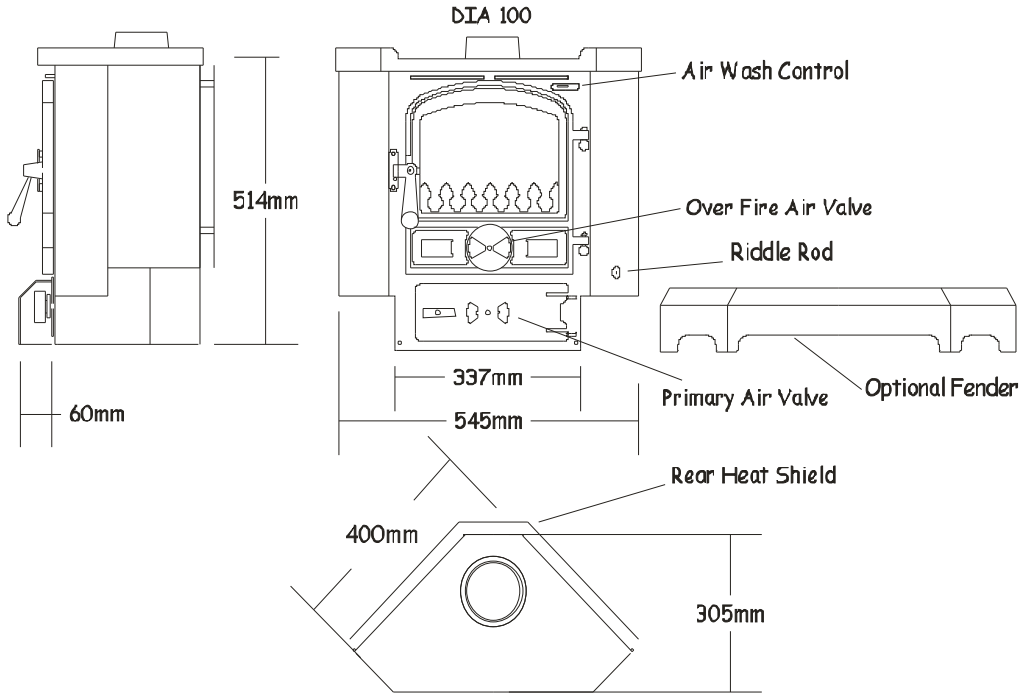

4B MULTIFUEL STOVE FIG 1

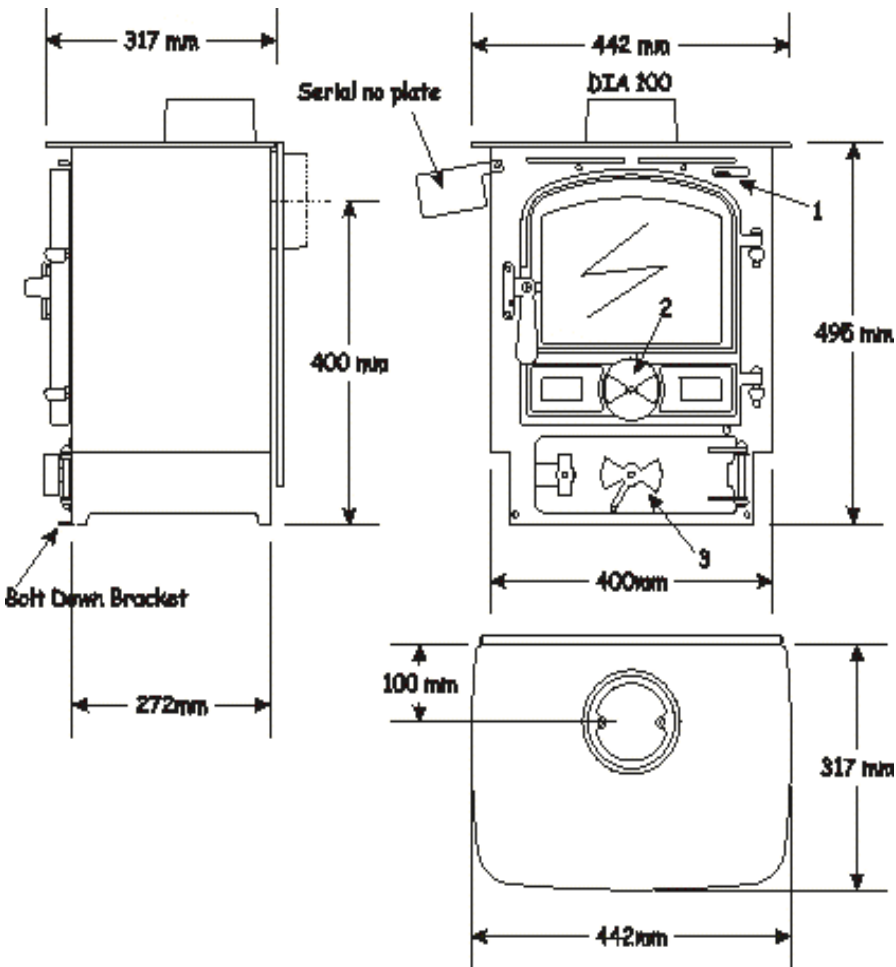

1 = airwash control, 2 = overfire air, 3 = underfire air

3B WOOD STOVE FIG 1

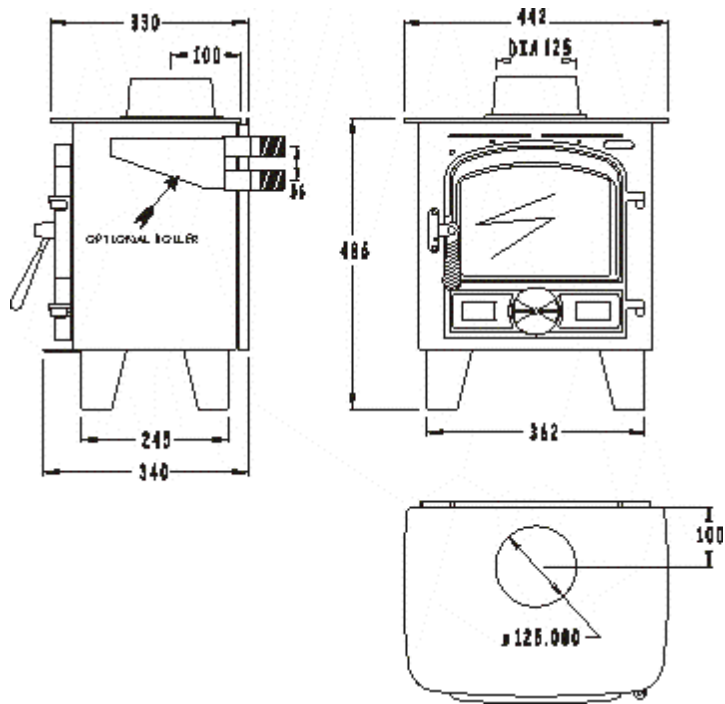

7B WOOD STOVE FIG 1

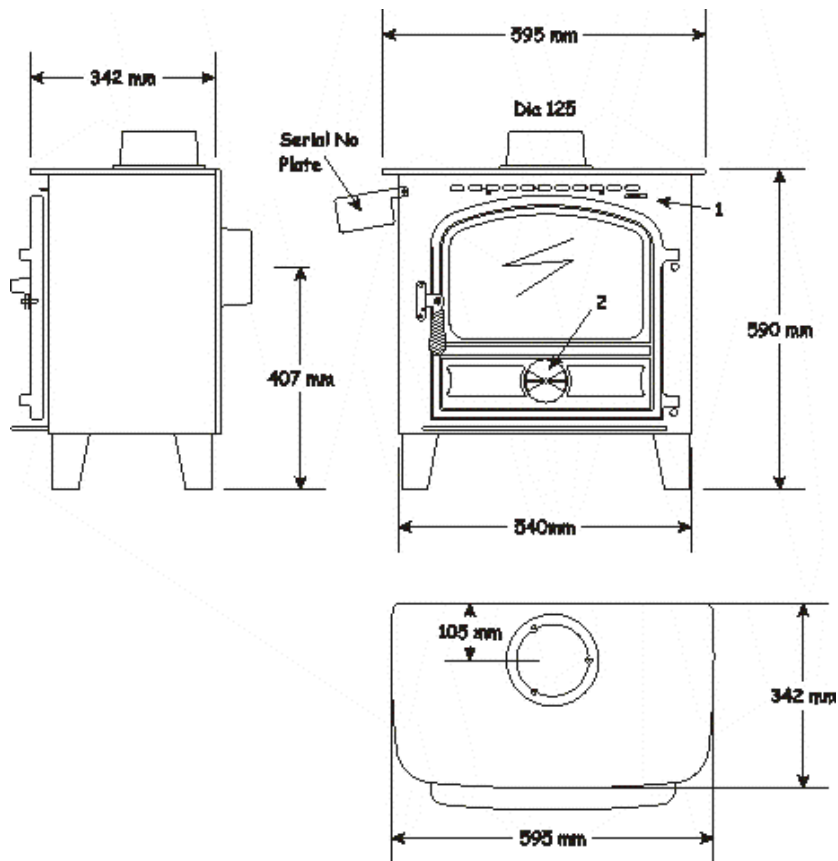

1 = airwash control, 2 = overfire air

DIMENSIONS OVEN STOVES

3B CORNER MULTIFUEL POD FIG 1

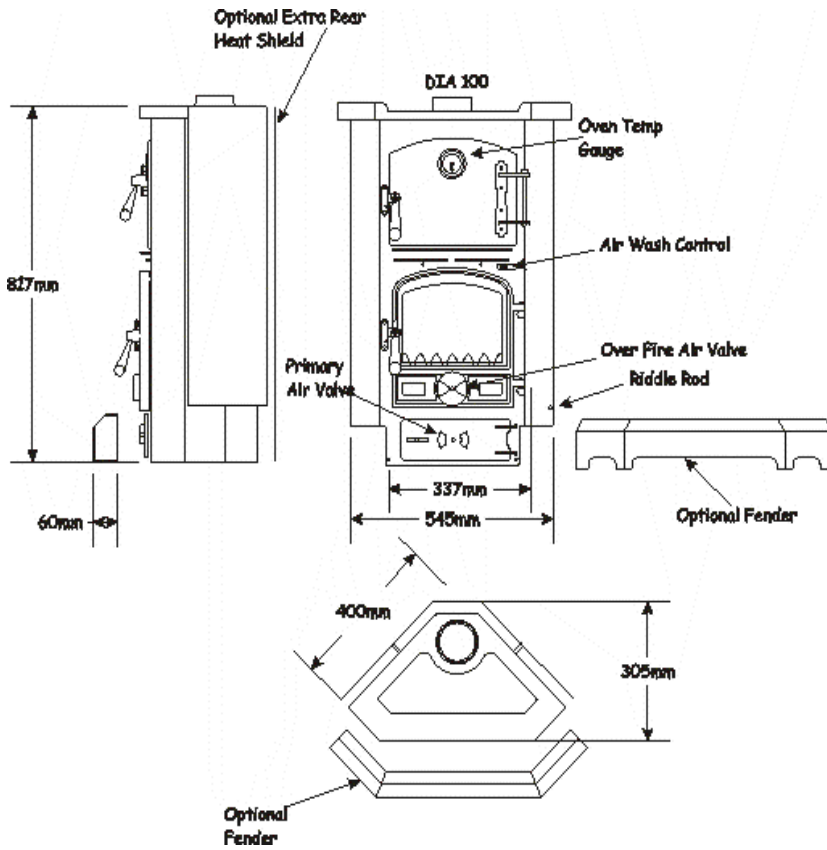

4B MULTIFUEL POD FIG 1

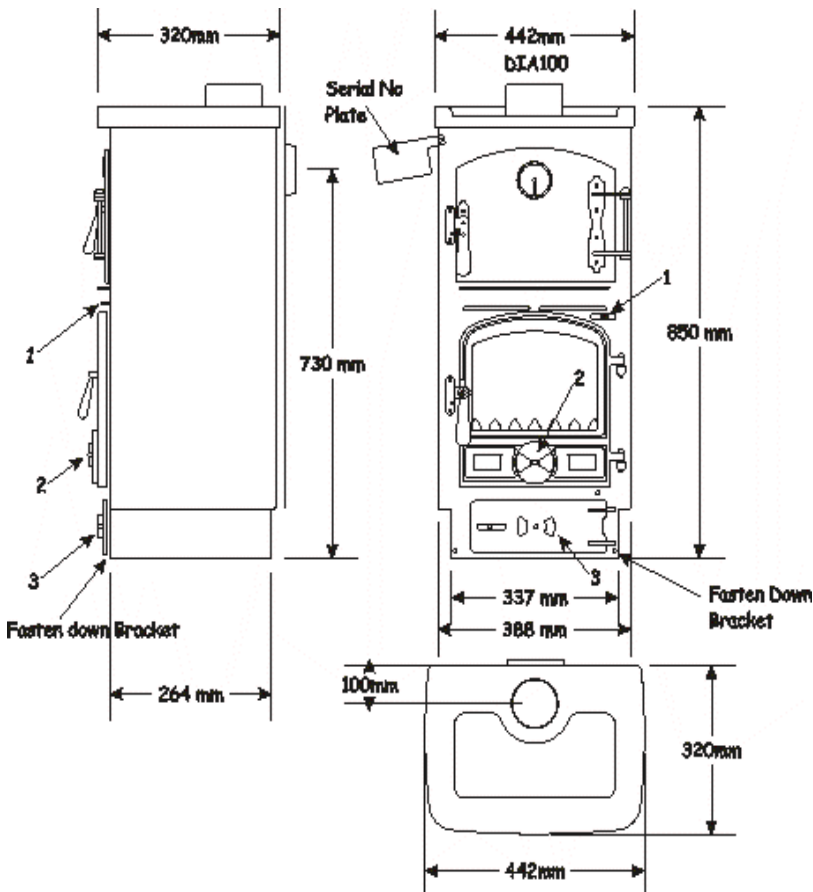

7B WOOD POD FIG 1

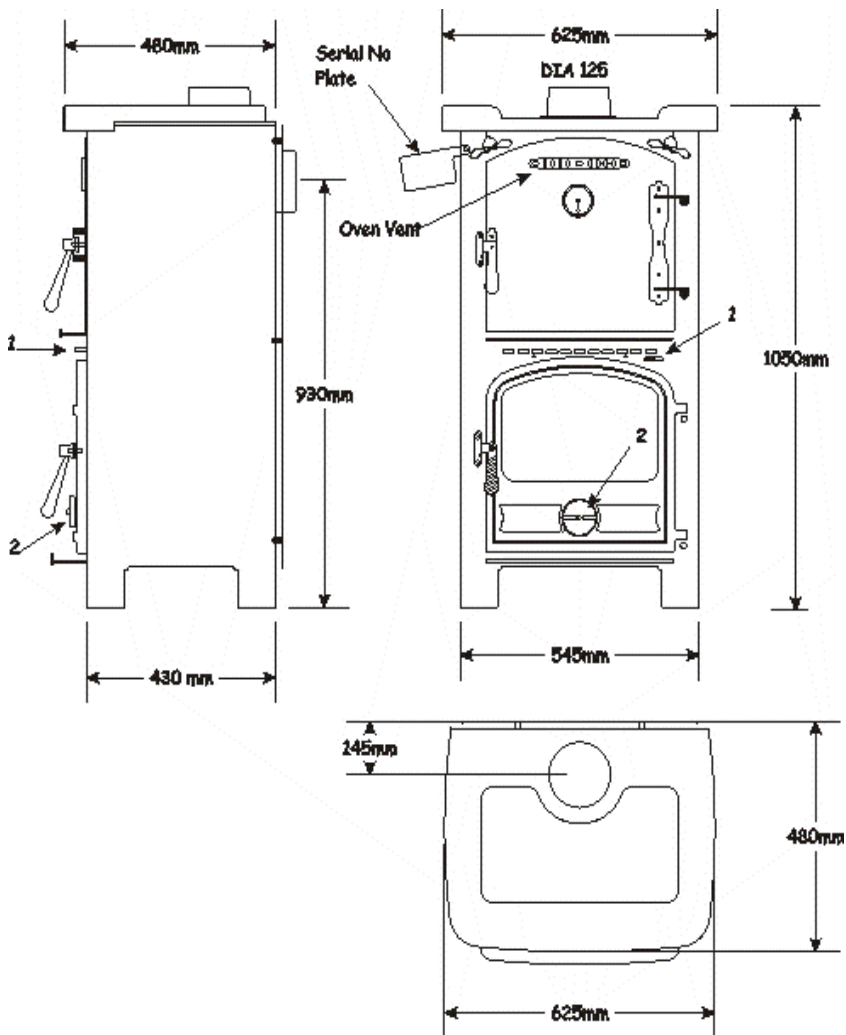

PIE POD MINI, BACK CABIN COOKER

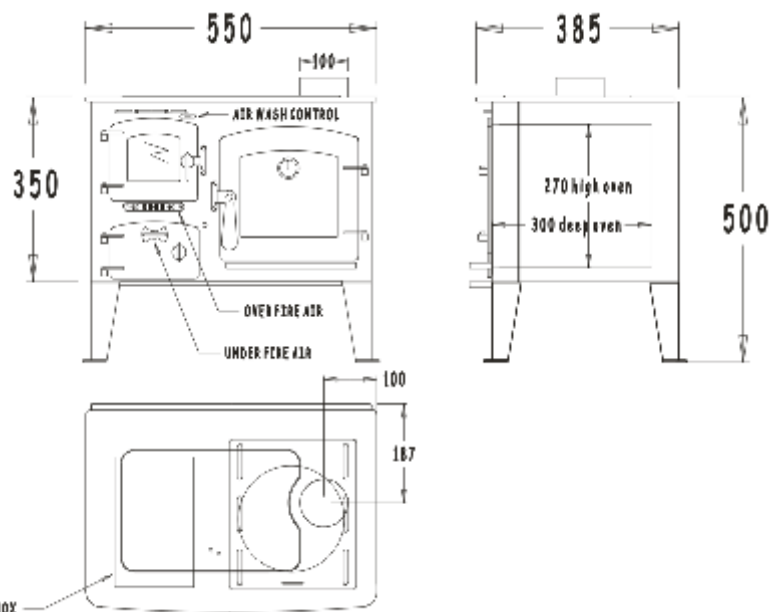

HEARTH AND FIREPLACE REQUIREMENTS

Hearth and fireplace construction are governed by Document J of the Building Regulations for Class 1 Appliances.

The stove must stand on a fireproof hearth and must not be situated too close to

combustible materials.

Details of minimum hearth sizes are set out in FIG1.

The fireplace must allow a good circulation of air around the appliance to ensure that maximum heat is transferred into the room and also to prevent the fireplace from overheating.

A gap of at least 6" either side, 18" above and 3" behind the appliance should allow sufficient air circulation but be aware that the Building Regs may well call for greater distances.

If a wooden mantelpiece or beam is used in the fireplace construction, it should be a minimum of 18 inches and preferably 24 inches from the appliance in both vertical and horizontal directions.

In some situations it may be necessary to shield the mantelpiece or beam with a suitable fireproof material.

FIG 2 RECTANGULAR APPLIANCES AND COOKERS HEARTH SIZE REQUIREMENTS

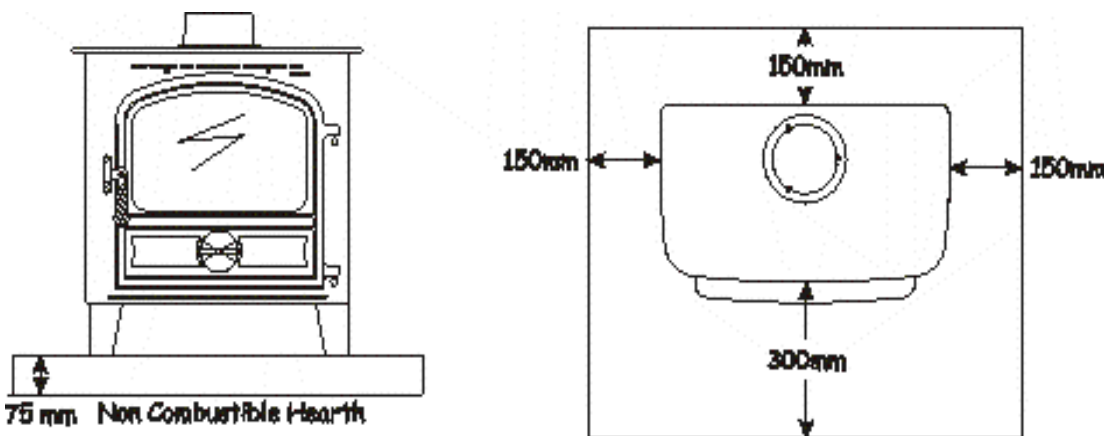

DISTANCES FROM COMBUSTIBLE MATERIALS

Dimensions shown in Table 2 are the minimum safe distances which combustible materials should be kept away from the wood or oven stove.

Note that on some appliances the rear clearance is reduced because of the rear heat shield or the rear face of the boiler, in both cases the radiated temperature is reduced.

Table 2

	FRONT	REAR	SIDES	ABOVE	HEARTH DEPTH
STOVES					
CORNER	600	300	600	600	75
WET VERSION	600	150	600	600	75
3B	600	300	600	600	75
WET VERSION	600	300	600	600	75
4B	600	300	600	600	75
WET VERSION	600	300	600	600	75
7B	600	300	600	600	75
SMALL BOILER	600	300	600	600	75
LARGE BOILER	600	300	600	600	75
OVEN STOVES					
CORNER POD	600	300	600	600	75

WET VERSION	600	300	600	600	75
4BPOD	600	300	600	600	75
WET VERSION	600	300	600	600	75
7BPOD	600	300	600	600	75
SMALL BOILER	600	300	600	600	75
LARGE BOILER	600	300	600	600	75
MINI COOKER	600	300	600	600	75

FIG 3 CORNER APPLIANCE DISTANCE FROM COMBUSTIBLES

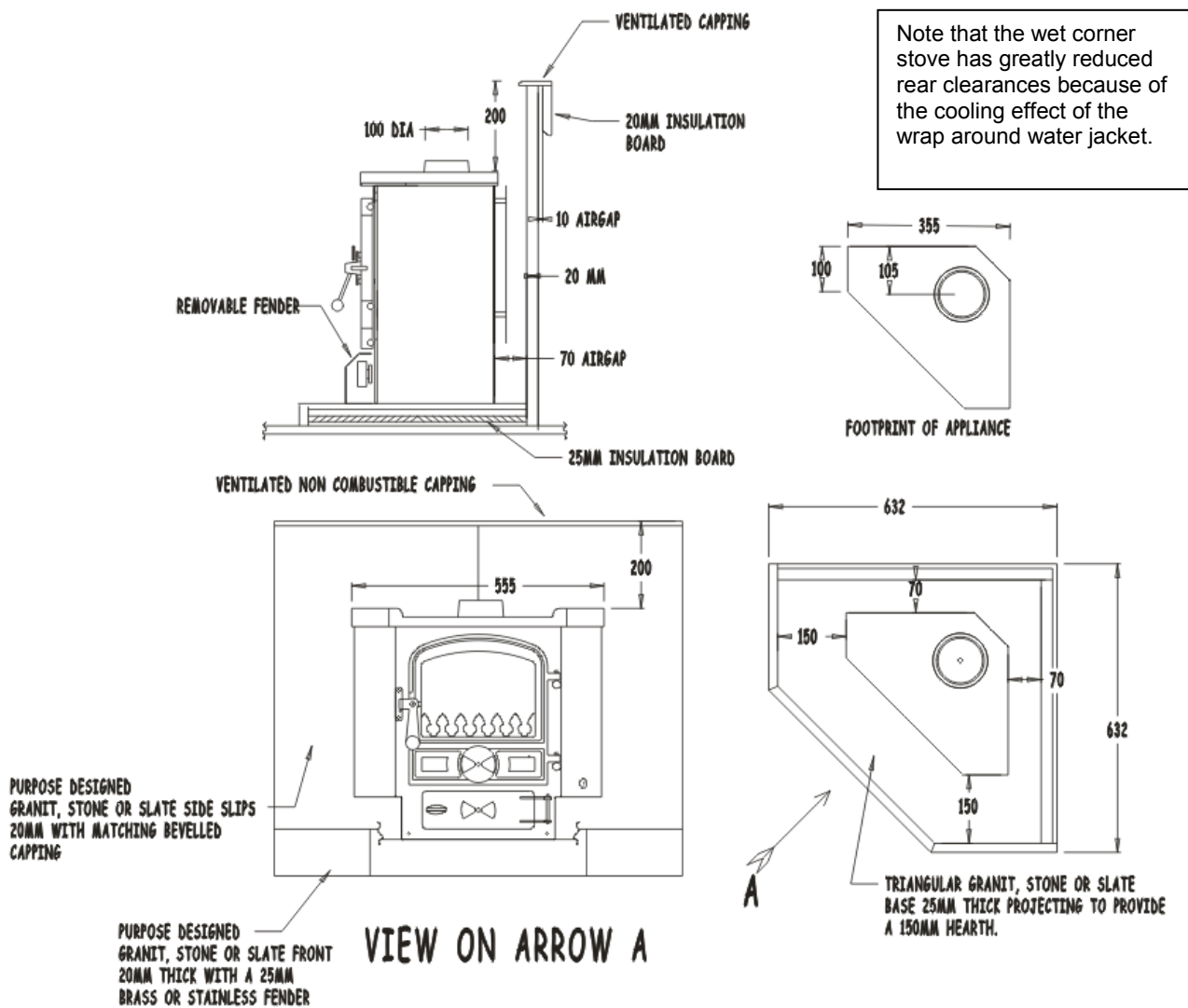
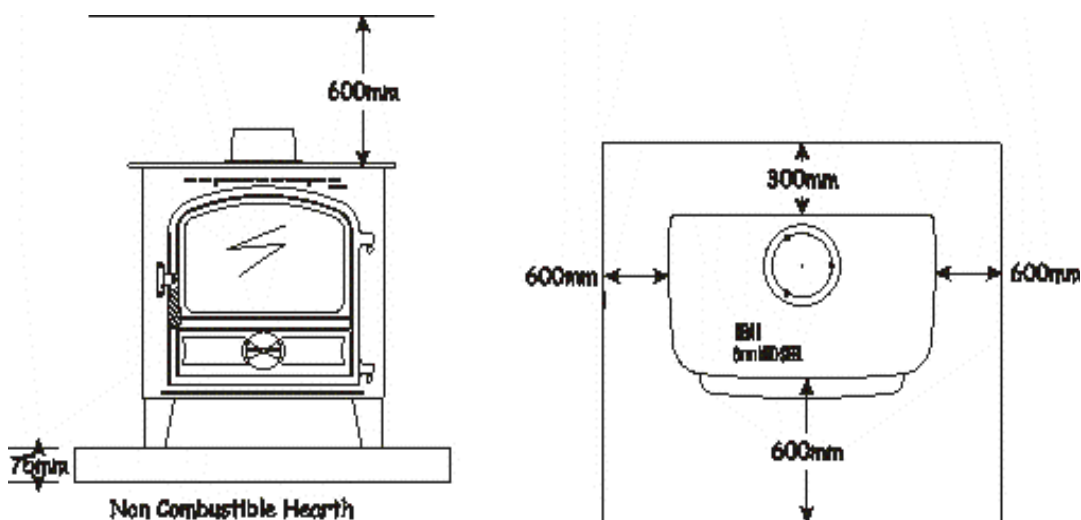

Fig 4 Rectangular Appliances and Cookers Distances from combustibles



CHIMNEY SYSTEMS.

The stove must be fitted with our MK3 flue system as illustrated in figs 4 & 5.

The primary flue pipe is fabricated from 4" O.D. tube with a minimum wall thickness of 3mm.

It must be fitted with a flue guard to cover the possibility of anyone touching it and to comply with the distance from combustibles requirement.

The flue pipe will normally run at a slight angle to allow it to terminate through the ceiling, in a suitable position. (*Max 8 deg from vertical.*)

It is important to make sure that the flue pipe fits concentrically at both the stove end and as it connects to the twin wall adaptor.

Always fit a rotary swinging cowl to the chimney terminal as illustrated in fig 4.

FIG 4 GENERAL LAYOUT OF TYPICAL FLUE.

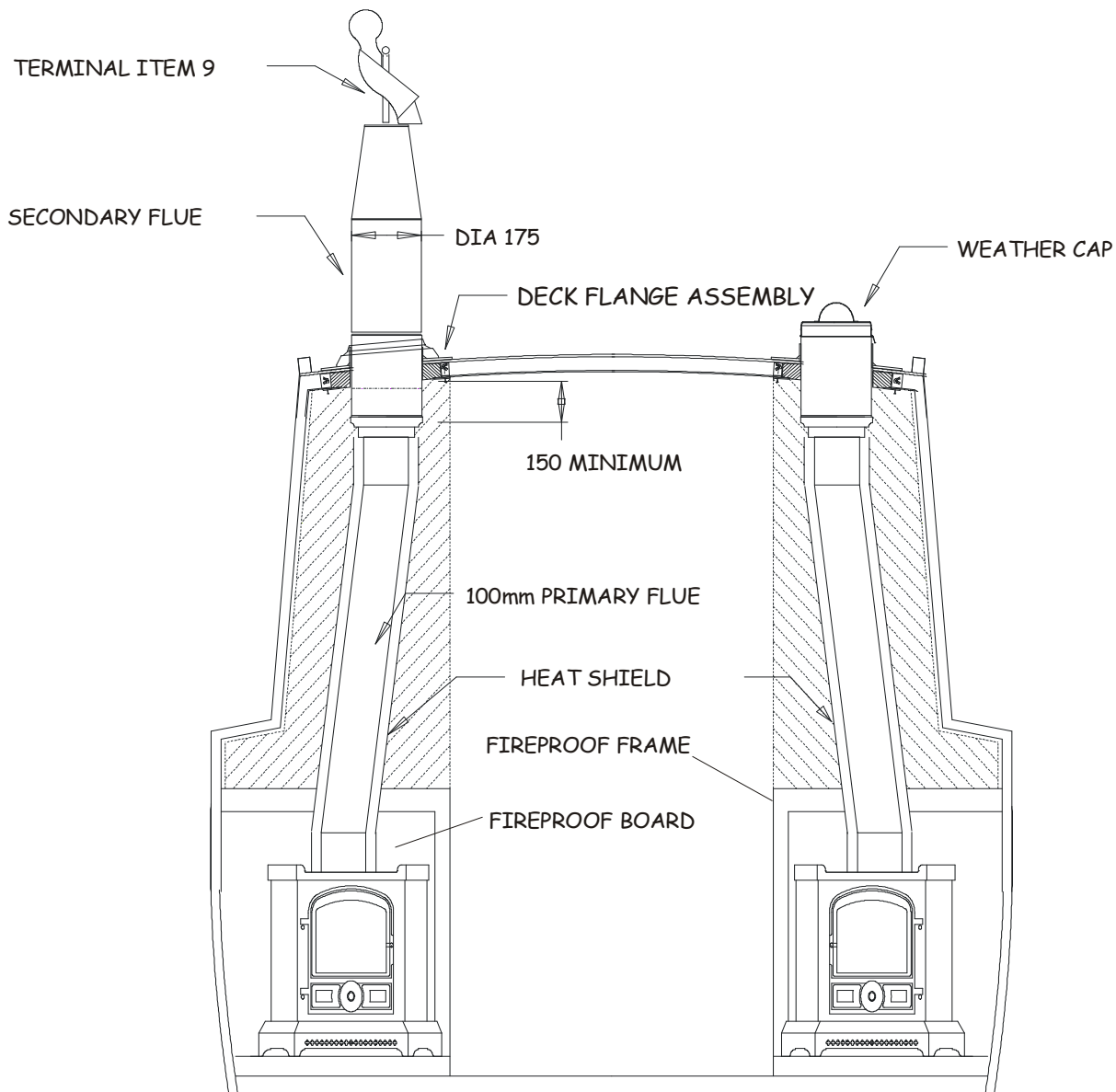
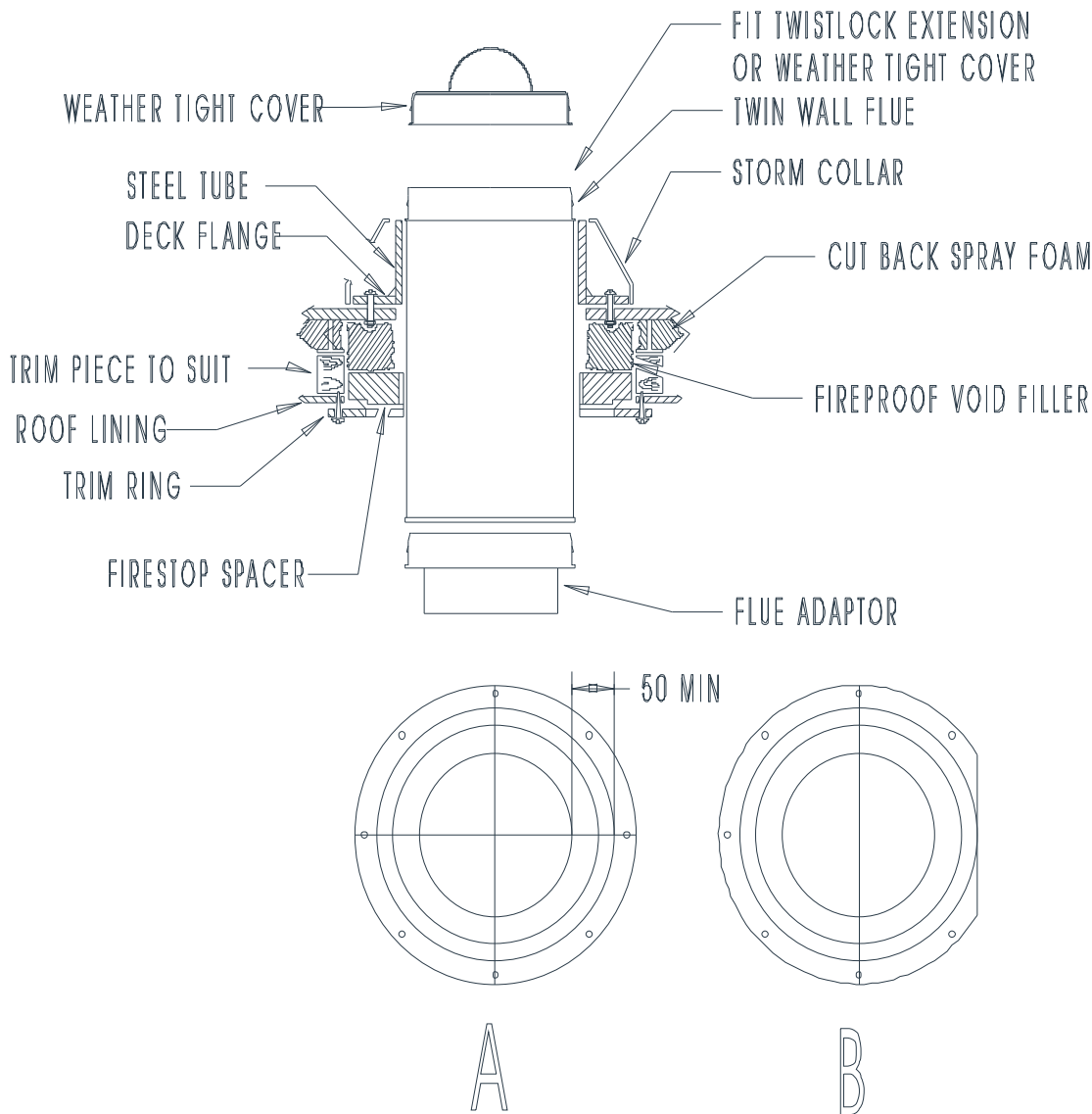

FIG 5 GENERAL LAYOUT OF MK3 DECK FLANGE ASSEMBLY.



These chimneys must be fitted in accordance with the manufactured instructions and current building regulations.

Avoid using bends greater than 45 deg to the vertical; all flue pipe sections should be as close as possible to the vertical.

Single wall flue pipe to BS 1344 part 3 is suitable for connecting from the appliance to the chimney but it is not suitable for using as a complete chimney.

When fitting single wall flues always make sure that they are fitted socket uppermost and spigot down. (Note that spigot is the reduced end.)

If it is found that there is an excessive draw in the chimney a draft stabiliser must be fitted.

It is important that there is sufficient draw in the chimney and that the chimney does not suffer from down drafts.

The flue draft test hole should be drilled into the chimney as close to the appliance as possible but before any flue draft stabiliser. After taking readings the test hole should be

plugged with a suitable bolt.

The flue draft readings should be taken when the appliance is at minimum firing rate and maximum firing rate.

When taking readings get the appliance up to the required temperature and then make sure that the primary air is closed and the air wash is open.

The chimney vacuum should be within the figures stated in TABLE1.

See fig7 for general guidance on flue heights and terminal positions.

If in doubt seek expert advice.

CONNECTION TO FLUES.

Stoves can be connected to flues using single wall flue pipe of suitable diameter, see TABLE 1 for relevant flue pipe diameters.

All connections must be correctly sealed to prevent any smoke or fume leakage.

If in doubt seek expert advice.

VENTILATION.

The provision of ventilation for this appliance is 550mm sq for each kilowatt of stove output.

STOVES	OUTPUT TO WATER IN KW	OUTPUT TO SPACE IN KW	TOTAL OUTPUT IN KW	VENTILATION IN CM SQ
CORNER MF		1-4KW	4KW	22
WET VERSION	1-3KW	1-2KW	5KW	27.5
3B WOOD		1-3KW	3KW	16.6
BOILER VERSION	1-2KW	1-3KW	3KW	16.5
B4 MF		1-5KW	5KW	27.5
WET VERSION	1-3KW	1-2KW	5KW	27.5
B7		2-7KW	7KW	38.5
SMALL BOILER	1-3KW	1-4KW	7KW	38.5
LARGE BOILER	2-8KW	1-3KW	11KW	60.5
OVEN STOVES				
CORNER MF POD		1-4KW	4KW	22
WET VERSION	1-3KW	1-2KW	5KW	27.5
B4 MF POD		1-5KW	5KW	27.5
WET VERSION	1-3KW	1-2KW	5KW	27.5
B7POD		2-8KW	7KW	38.5
SMALL BOILER	1-3KW	1-4KW	7KW	38.5
LARGE BOILER	2-8KW	1-3KW	11KW	60.5
MINI COOKER	1-3KW	3kW	3KW	16.6

If the appliance is fitted into a location which has an extractor fan fitted, additional ventilation will be required to compensate for the effects of the extractor unit.

Where air for ventilation is taken from another space and not directly from outside air, the ventilation allowance needs to be doubled.

Make sure that the appliance is fully and correctly assembled, and that the baffle plate is correctly fitted.

Make sure that the front fret is correctly fitted and that the door or doors are closed.

COMMISSIONING DRY STOVES.

PRE FIRING CHECKS.

Check the following, to make sure that they fully comply with the instructions given in these instructions.

1. Fireplace location, design and compliance with these instructions.
2. Fixing and fitting of the appliance and flue system.
3. Integrity of the flue system, after first pre heating the chimney system with a blow gun carry out a smoke test on the appliance and chimney system to make sure that there are no leaks from either the appliance or the chimney system.
4. Distances from combustibles.
5. Ventilation.
6. Open all the doors, windows and ventilators before firing the appliance to ventilate any first firing fumes.
7. Light the appliance.
8. Make sure that there is a suitable carbon monoxide alarm fitted in the same room as the appliance and make sure that it can be heard where the boat occupants normally sleep.

Make sure that the alarm is correctly functioning.

9. Make sure that a suitable fire guard is fitted.

POST FIRING CHECKS (DRY STOVES.)

When the appliance is going check that there are no fume leaks on the flue pipes and check that none of the surrounding combustible materials are overheating or showing signs of overheating.

INSTRUCT THE USER (DRY STOVES.)

Instruct the user on the principles of operation.

WARRANTY.

Fill in the warranty registration details to return to us.

COMMISSIONING WET STOVES.

Carry out all the checks as detailed in commissioning above and then, check that the heating system is adequately designed, complies with current good practice.

Check that the boiler is connected up correctly and suitably cross flowed.

Check that the cold feed and expansion are correctly sized for solid fuel applications.

Check that there is an adequate flow of water through the boiler.

Check that there is an adequate flow of water through the hot water cylinder.

Check that there is an adequate flow of water through the radiators.

Check that there is no over pumping.

Check that there are no air locks preventing all of the radiators and the hot water cylinder from heating up correctly.

Air locks can be caused by:-

Poor quality pipe runs which do not allow air to rise and vent trapped air off.

Check that when the water circulating pump is turned on it does not remove heat from the hot water cylinder. *This normally occurs if the pipework and pumping arrangement is not designed correctly.*

Check that the appliance is not fitted out of level allowing an air pocket to build up in the top of the boiler causing subsequent kettling.

Check that all safety devices such as the pressure relief valves are fitted and working correctly.

INSTRUCT THE USER (DRY STOVES.)

Instruct the user on the principles of operation.

GUARANTEE

Conditions of Guarantee

Your Bubble appliance is guaranteed against defects arising from faulty manufacture for a period of one year subject to the following express conditions.

Failure to comply with these conditions will invalidate the guarantee.

1. The Bubble appliance must be installed by a suitably qualified engineer.
2. Upon installation the receipt must be kept as proof of purchase.
3. The guarantee lasts for one year from the date of purchase.
4. The guarantee does not cover parts deemed to be replaceable in the normal use of the appliance, these parts are:-

Grates, Ash pan, Side and Back Bricks, Baffle Plates, Door Rope Seal and Door Glass.

HOW TO PROCEED WITH A COMPLAINT.

If you have cause for dissatisfaction with your Bubble appliance you should first contact the Bubble dealer or whoever you purchased the appliance from.

Your supplier should bring your concerns to our attention and we will assess the nature of the complaint.

We will either send replacement parts or nominate a regional engineer to inspect the appliance and carry out any remedial work that may be required.

If the fault or problem is not due to faulty manufacture but some other cause such as:- Misuse, failure to install correctly, failure to service at regular intervals, a charge will be made to cover the cost of the visit and any new parts required.

GLOSSARY OF TERMS.

Downdraught. A wind effect creating a situation where air is being either blown or sucked down the flue pipe.

Chimney vacuum. The negative pressure, which the chimney system is able to generate.

Class 1 Appliances. Wood and solid fuel burning appliances where the flue gas temperatures are expected to exceed 260 deg C.

Combustible materials. Any liquids, vapours or materials in close proximity to the appliance, which can easily ignite with the application of heat or flame.

Thermostat. A device for controlling temperature.

Multi fuel stove. A stove which can accommodate all the combustion and other technical requirements of wood, coal and smokeless fuel burning.

Volatiles. Combustible entrapped components of hydrocarbon fuel.

Kettling. Hissing noise like that issued from a kettle just before it reaches boiling point.

Gravity system. Term used to describe a central heating system through which hot water will flow, without the use of a circulating pump.

Pumped system. Term used to describe a central heating system through which hot water is forced to flow, by the action of an electrically operated circulating pump.

Pressure relief valve. A device designed to allow the release of pressure which may build up in the hydraulic circuitry due to excessive temperature.

BIBLIOGRAPHY

BS 5839-6, Fire detection and fire alarm systems for buildings - Part 6: Code of practice for the design, installation and maintenance of fire detection and fire alarm systems in dwellings

BS 8423, Fireguards for fires and heating appliances for domestic use

For approved fuels see www.uksmokecontrolareas.co.uk

For details of registered installers see www.hetas.co.uk

SPECIFICATION

BS EN 14604, Smoke alarm devices

BS EN 50291, Electrical apparatus for the detection of carbon monoxide in domestic premises - Test methods and performance requirements

BS EN 12828, Heating systems in buildings - Design for water-based heating

systems

BS EN 14336, Heating systems in buildings - Installation and commissioning of water based heating systems

Other publications

EUROPEAN COMMUNITY Recreational Craft (RC) Directive

94/25/EC amended by Directive 2003/44/EC (europa.eu.int)

© Euroship Services (UK) Ltd., Trading as Bubble Products ©

Copyright © Terry Hibbard

This publication must not be copied by any means without written permission from the authors.

This product is subject to continuous development and improvement and it is consequently acknowledged, that due to this process, there may be some omissions and errors.

This publication is intended only to assist the reader in the use of this product and therefore Bubble Products shall not be liable for any loss or damage whatsoever arising from the use of any information, error or omission found in this publication