

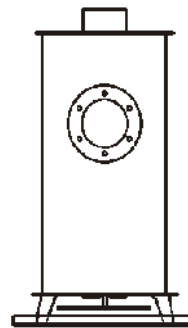

ALL MARINE OIL STOVES ©

COMMON INSTALLATION INSTRUCTIONS

ISSUE 6 @ 11-01-13

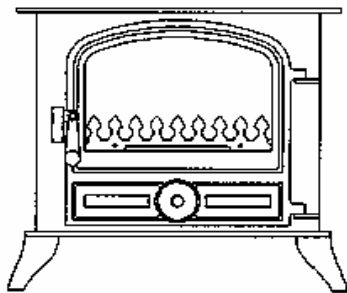
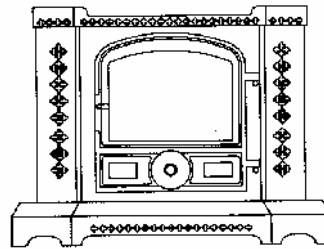
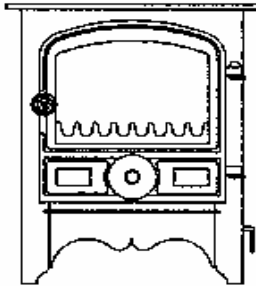

INDEX

1. BEFORE STARTING THE JOB	3
FITTING OPTIONS.....	3
ABOUT THE STOVES.....	3
2. SAFETY	4
FUMES.....	4
FIRE	4
BURNS.....	4
CLEARANCES FROM COMBUSTIBLES.....	5
CLEARANCES FROM COMBUSTIBLES-FLUE PIPES	5
VENTILATION.	5
FLOODED VAPOURIZING BURNER POTS.	5
SECURELY FIX THE APPLIANCE	5
3. CHIMNEY	5
THE HEIGHT.....	5
THE DIAMETER.....	5
THE TEMPERATURE OF THE GASSES IN IT.....	5
THE RESISTANCE OF THE INNER SURFACE OF THE FLUE PIPE OR PIPES.....	5
THE TYPE OF TERMINAL.....	5
THE PREVAILING ATMOSPHERIC CONDITIONS.....	5
THE CHIMNEY RULES.....	6
4. FUEL SUPPLY	6
WAXING.....	6
AIR LOCKS	6
TRIM.....	6
TANK.....	6
OIL LINE.....	6
WATER CONTAMINATION.....	7
REMOTE SENSING FIREVALVE	7
ISOLATION VALVES.....	7
SLEEVING.....	7
OVERBOIL OR OVERHEAT PROTECTION OF THE APPLIANCE.....	7
5. FIREPLACE	7
DISTANCES FROM COMBUSTIBLES (STOVES).....	8
DISTANCES FROM NON COMBUSTIBLES (STOVES).....	8
DISTANCES FROM COMBUSTIBLES (FLUE PIPES).....	9
FIG 1. STOVE DISTANCE FROM COMBUSTIBLES	9
FIG 2 HARWORTH FABRICATED DECK FLANGE LAYOUT.....	10
FIG 3 TYPICAL OIL FEED LAYOUT	10
FIG 4 TYPICAL PLUMBING CIRCUIT LAYOUTS.....	11
6. NORMATIVE REFERENCES	12

If you have any difficulties please phone our technical help line on:-

01302 742520 fax 01302 750573

e mail sales@oilstoves.co.uk.

www.oilstoves.co.uk

1. BEFORE STARTING THE JOB.

THE FOLLOWING NOTES PROVIDE INFORMATION FOR INSTALLATION OF THE FOLLOWING APPLIANCES.

Boat Bubble No 1, Dry Small and Large Boiler Stoves

Boat Bubble No 2 Dry Small and Large Boiler Stoves

Marine Corner Bubble Wet and Dry stoves

Marine Round Bubble Wet and Dry stoves

Marine Belfort Wet and Dry stoves

FITTING OPTIONS.

There are normally three different situations that the installer may be faced with:-

A new build installation.

An established boat installation, (which has not had a oil stove fitted).

A replacement installation, where there has been a solid fuel stove fitted previously.

Each of the situations will present differing problems which will be:-

- Where to locate the stove.
- How to deal with fireplace design.
- Where to locate the oil tank.
- How to get an oil supply to the stove.
- How to fit the chimney.
- How to connect water to the stove.
- How to disconnect and remove the stove, easily.

The new build situation should be the easiest.

The established boat situation will require careful attention to the sighting of the stove in relation to flue positions and existing fittings positions.

In replacement situations it may well be necessary to blank off the existing through roof flue position and cut a fresh one to suit the new location.

ABOUT THE STOVES

The stove is a space heater, which burns diesel oil in a controlled manner utilizing a chimney to discharge the products of combustion.

The stove generates heat from burning oil mixed with air in a vaporizing pot located in the bottom of the stove.

Once ignited, oil goes into the pot at a steady and controlled rate via gravity flow, metered by the OIL CONTROL VALVE the oil flow can be controlled from minimum to maximum or any setting in between determined by where you set the oil flow control knob.

Air is sucked into the pot by the natural action of the negative pressure in the chimney and to allow the chimney to work correctly it is essential that you have adequate, unrestricted ventilation into the area where the stove is situated.

The amount of oil that can be successfully burned is directly proportional to the amount of air that the chimney can draw into the pot and so to achieve adequate combustion a balanced and appropriate flow of both oil and air is required.

The stove will provide space or combined space and water heating.

There are three versions of the stove

Space heating only.

Space heating and a small boiler

Space heating and a large boiler.

On the boiler versions there are 2 x 1" BSP female sockets for water connections to be made.

Both boilers are high water content and suitable for pumped or gravity systems, pressurised or open vented, provided that they are correctly designed.

The stove incorporates a removable front apron, which on manual ignition stoves is used to gain access for lighting.

On the right hand side of the stove is a small lever which should be rotated occasionally to descale the oil inlet pipe.

The stove must not be operated with the glass front door opened or cracked, or without the lighting port plug fitted.

The door glass may require light cleaning occasionally depending upon the continuous running time of the stove.

The stoves must be securely bolted down so that it can resist impact or collision and it must be level in both directions.

The top of the stoves can be used for warming and cooking.

Some stoves can also be supplied with or without a coal kit.

Just like a solid fuel stove, coal effect will only be available when the stove is running at maximum or near maximum performance which is 4kW OR 14,000 B.T.U, s PER HOUR.

Suitable deck flanges and flue systems must be used.

We strongly advise the use of a suitable anti downdraft terminal.

CONTROLS

The output of the stove is regulated by the amount of oil allowed to go into it and this function is controlled by the -:

OIL CONTROL VALVE (O.C.V.),

Turning the knob anti clockwise controls the oil flow. Controls for the stove will vary, depending on which valve is fitted to it.

The valve could be a ships valve or a Toby valve.

The control for the dry stove comprises-:

1. Oil flow control only. (Ships Valve)

The boiler version has extra controls which are-:

1. Oil flow control
2. Oil valve trip lever
3. Thermostat control
4. Overheat device with manual re-set.

The Toby oil control valve used on boiler stoves has a modulating thermostat control, which will put the fire on to low fire when the target temperature has been achieved.

In addition to this there is also a device which will shut the burner down, should the water exceed 90 deg C., the device can be reset should it trip off.

The Toby valve has to be tripped into action by lifting the trip button.

The flow of oil into the pot can be adjusted via the knob on top of extension rod rising up from the oil control valve.

2. SAFETY.

Take care to make sure that safety and ventilation issues are adequately addressed.

FUMES

Always fit a suitable Smoke and Carbon Monoxide alarm.

Make sure that the function is checked on regular basis.

Fit the alarms in such a position that in the event of an alarm being triggered the noise from it will wake you up should you be sleeping.

Here are the main causes of fume or smoke to leak from the stove.

- The chimney is blocked.
- There are too many bends in the chimney.
- The above deck chimney extension is not high enough.
- The boat is moored in a position near to high buildings or trees and downdraughting is occurring.
- The chimney is not airtight.
- There are unusually strong cross winds

If downdraughting occurs turn the appliance off until the winds subside.

FIRE

Fire can be caused by a variety of potential danger points and because of the space limitation on boats; this risk is ever present and must be adequately assessed.

The main danger is the effects of heat from the stove on combustible materials and boat occupants.

Make sure that all combustibles are adequately protected from the effects of heat radiation.

The stove must stand on a fireproof base of minimum thickness 30mm.

Floors in front of the stove must have suitable fire protection.

Built in stove heat shields should not be removed under any circumstances.

BURNS

During normal, day-to-day use, many parts of the stove, pipe work, and chimney will become too hot to touch.

These hot surfaces must be adequately protected to prevent anyone falling on to, or touching them.

Suitable fireguards for the appliance and chimney must be fitted.

Fireguards must comply with BS6539.

Always use heatproof gloves when working on or near to a hot stove.

CLEARANCES FROM COMBUSTIBLES

The stoves must be fitted in line with the distances specified in the table.

All hearths and fireplaces must be made from non-combustible materials.

CLEARANCES FROM COMBUSTIBLES-FLUE PIPES

Flue pipes must be fitted in line with the distances specified in the table.

Any combustible materials within the specified distances from the stoves must be protected by a suitable heat shield.

Protection can be gained by the use of -:

- Sheet metal heat shields and spacers.
- Heat resistant boards such as TAC board.

Combustible materials can be-:

- Wooden furniture.
- Curtains.
- Wooden panels or frames adjacent to the flue pipe or where it passes through the deck of the boat.
- Carpet or flooring close to the stove.
- Items near to the stove, which could fall onto it and ignite, should the boat suffer a slight impact or collision.

VENTILATION.

Ventilation plays a vital role in the fitting and sighting of any stove.

The provision of ventilation for these stoves is adequately covered by the requirements of the boat safety scheme.

25cm² minimum permanent ventilation, directly to outside air, must be provided.

FLOODED VAPOURIZING BURNER POTS.

When attempting to light a stove, make sure that the pot is not flooded with oil by looking into the base of the burner.

If it is flooded remove the excess oil as per instructions in the faultfinding manual.

Never try to relight a hot stove; wait until it has cooled down.

Hot oil vapour is explosive.

Never try to light a flooded pot.

SECURELY FIX THE APPLIANCE

The stove must be securely fastened down so that it can resist impact or collision and it must be level in both directions.

Level the stove in both directions when the vessel is midway between its maximum and minimum trim conditions.

Bubble stoves must not be fitted if the maximum angle of trim exceeds 1 deg forward to aft or port to starboard.

The stove must not be operated with the glass front door opened or cracked, or without the lighting port plug fitted.

Qualified persons can only install unvented plumbing systems.

A suitable and serviceable fire extinguisher should always be readily accessible.

3. CHIMNEY

This is the one of the most interesting problems the installer has to deal with and as the chimney affects most aspects of running the stove, we take time here to list the following information for your consideration.

The power, (*suck or vacuum the chimney can develop*) depends upon the following-:

THE HEIGHT.

THE DIAMETER.

THE TEMPERATURE OF THE GASSES IN IT.

THE RESISTANCE OF THE INNER SURFACE OF THE FLUE PIPE OR PIPES.

THE TYPE OF TERMINAL.

THE PREVAILING ATMOSPHERIC CONDITIONS.

It is obvious that on a boat all the above elements are in short supply.

Normally, we have low flues which are small in diameter and generally not very well insulated, coupled with all these problems we have another one, which is that the boat moves across constantly changing surroundings, through locks, into headwinds and crosswinds, all creating major opportunity for down draughting to occur.

Any bend in any part of the chimney or roughness on the internal chimney wall will slow down the velocity of rising gases and reduce the effectiveness of the chimney.

Any slight reduction in the flue gas temperature will reduce the chimney vacuum or pull, hence when the stove is slowed down for all night burning, as the flue gas cools down the chimney vacuum reduces and as the chimney vacuum drops, the stove may well start to burn sooty. This problem is highlighted even more during very cold weather when the chimney can cool down even faster. In these situations careful attention to servicing and low fire setting is essential.

THE CHIMNEY RULES.

1. Always use a top outlet for flue pipe take off.
2. Always try to get the stove as low as possible in the boat, this will allow installation of maximum length flue pipe.
3. Clean or have the chimney cleaned regularly. (Frequency depends upon type of fuel and length of time used).

4. FUEL SUPPLY.

There are several problems relating to diesel fuel supply, which need to be adequately addressed.

WAXING

Cold weather waxing or thickening alters the flow characteristics of diesel.

An adequate fuel feed supply can turn into an inadequate one when the temperature starts to fall.

The worst scenario is fuel feed pipe 50-60 feet long in 8mm dia pipe.

The best-case scenario is a fuel pipe 4 feet long in 10mm dia with insulated lagging.

AIR LOCKS

Air lock in oil feed pipework must be avoided.

The pipe work must slope down to the appliance and be clipped level at 500mm intervals to prevent sagging.

Any rises in the pipework will cause air locks on commissioning and after future oil run out situations, if it is not possible to run the pipework in a steady slope then where changes occur a vertical venting leg should be fitted.

TRIM

Bubble stoves must not be fitted if the maximum angle of trim exceeds 0.75 deg forward to aft or port to starboard.

Level the stove in both directions when the vessel is midway between its maximum and minimum trim conditions.

A minimum pressure head of 10" is required.

This head is measured from the base of the oil tank to the top of the oil control valve. In some cases this head can be affected by the ballast or trim of the boat.

Take great care to try out all the different ballast and trim possibilities to make sure that adequate oil feed is always available at the outlet end of the fuel pipe before it enters the oil control valve at the stove.

TANK

If the stove is fitted at the bow of the boat, a bow tank is recommended.

The tank should comply with the requirements of the boat safety scheme and have:-

- A conveniently sized filler
- A means of venting.
- A conveniently located, easily visible, contents gauge.
- An isolation valve
- An easily replaceable cartridge filter.
- A suitable and substantial water trap

Do not use glass filter bowls, they are not acceptable under the boat safety scheme.

Make sure that your fuel supplier supplies you with appropriate fuel for wintertime running.

OIL LINE

The oil feed line starts after the fuel filter and proceeds to the point of entry, which is where the oil line goes into the cab or saloon of the boat.

The diameter of the oil line is dependant upon the length of run. See 3-2 on waxing and make sure that you have suitably sized compression fittings available.

At this point it is necessary to fit a 60 DEG C, remote sensing fire valve, designed to shut off the oil supply, should a fire occur near to the stove.

If the bubble stove is fitted up to the first bulkhead it will be necessary to fit the isolation valve outside the cabin or saloon of the boat.

WATER CONTAMINATION

Because of the high risk of fuel contamination with water, we strongly recommend the fitting of a **high volume water trap**, in the oil supply line.

REMOTE SENSING FIREVALVE

The fire valve has a capillary tube on the end of which is a temperature sensitive phial, run the capillary tube with the oil line up to the stove and carefully fit the sensing phial 15mm pipe clips in front of the drip tray on the fireplace hearth, directly in front of the combustion air restrictor.

Before it is fitted try the fender on the stove to make sure that the fender does not foul the sensing phial.

The sensing phial may be visible through the bottom of the fender, to mask it, paint it with matt black paint available from our sales desk.

When fitting the fire valve make sure that where the capillary and oil line go through the bulkhead in separate sleeved tubes, so that the capillary can be withdrawn separately should it ever need replacing.

For fitting of long oil feed lines which pass through bulkheads and various other parts of the boat it may well be necessary to fit more than one fire valve, especially where the oil line passes through an area where a fire could occur i.e. kitchen area etc.

ISOLATION VALVES.

Two isolation valves are required, one fitted directly into or close to the oil control valve to allow you or the service man to turn the oil off should the need arise, and one fitted directly into the oil tank before the fuel filter.

Always turn off the oil isolation valve serving the appliance before leaving the vessel unattended.

SLEEVING.

Where the oil line goes through the boat superstructure a suitable bulkhead fitting must be used.

OVERBOIL OR OVERHEAT PROTECTION OF THE APPLIANCE.

Where Toby aquastats have not been fitted to the oil control valve, an additional 90 DEG C, remote sensing fire valve fitted either into, or close to the oil control valve may be fitted.

The sensor from this valve has to be attached to the water jacket or the hot outlet pipe from the boiler.

The valve is calibrated to shut the oil supply down should the water temperature exceed 90 Deg C.

There is a re set button which needs to be pressed in to re set the valve after it has tripped off.

5. FIREPLACE.

Always fit the stove on a suitable drip tray.

The possibility of oil drops leaking from the stove must be considered, a suitable oil drip tray must be fitted and designed in such a way, as it will contain any oil leaks or drips.

Normally the tray will cover the footprint of the stove, the oil valve and isolation device.

It will be oil tight and have a vertical upstand of at least 30mm. This should give a minimum containment volume of 2 litres.

It will be securely fastened down to the vessel and the appliance must be securely fastened down to the oil drip tray.

Make sure that drip trays are tested to ensure that they do not leak when filled with oil.

Use materials, which are easy to keep clean and fireproof such as tiles, asbestolux or vermiculite boarding.

The hearth must be-:

FLAT - SECURE - FIREPROOF AND LEVEL IN BOTH DIRECTIONS.

The vertical walls of the fireplace must be made from fireproof materials.

Use fireproof, rockwool infill behind the fireplace panels to protect any combustible insulation materials such as spray foam.

DISTANCES FROM COMBUSTIBLES (STOVES)

Stove Type	ABOVE	SIDES.	BACK	FRONT	HEARTH Non Combustible Material
BOAT B1	500	300	150 FROM HEAT SHIELD	300 to allow door opening.	30MM THICK x 100 projection at the front and sides
BOAT B2	600	300	150 FROM HEAT SHIELD	300 to allow door opening.	30MM THICK x 100 projection at the front and sides
BELFORT	500	300	150 FROM HEAT SHIELD	300 to allow door opening.	30MM THICK x 100 projection at the front and sides
CORNER	500	75	75 FROM HEAT SHIELD	300 to allow door opening.	30MM THICK x 100 projection at the front.

ROUND	200	ALLOW 300 ALL AROUND THE STOVE			30MM THICK x 100 projection all round
--------------	-----	--------------------------------	--	--	---------------------------------------

DISTANCES FROM NON COMBUSTIBLES (STOVES)

Stove Type	ABOVE	SIDES.	BACK	FRONT	HEARTH Non Combustible Material
BOAT B1	300	150	150 FROM HEAT SHIELD	300 to allow door opening.	30MM THICK x 100 projection at the front and sides.
BOAT B2	300	150	150 FROM HEAT SHIELD	300 to allow door opening.	30MM THICK x 100 projection at the front and sides.
BELFORT	300	150	150 FROM HEAT SHIELD	300 to allow door opening.	30MM THICK x 100 projection at the front and sides.
CORNER	200	150	25 FROM HEAT SHIELD	300 to allow door opening.	30MM THICK x 100 projection at the front and sides.

ROUND	200	ALLOW 150 ALL AROUND THE STOVE			30MM THICK x 100 projection
--------------	-----	--------------------------------	--	--	-----------------------------

DISTANCES FROM COMBUSTIBLES (FLUE PIPES)

For all stoves-:

1. Horizontal Distance = 50 for single skin pipes when fitted in the deck flange at the top of the chimney system, protected by the fire stop spacer.
2. Horizontal Distance = 150 when exposed in the saloon or living space.
3. Horizontal Distance = 30 mm for insulated flue pipe systems.

FIG 1. STOVE DISTANCE FROM COMBUSTIBLES

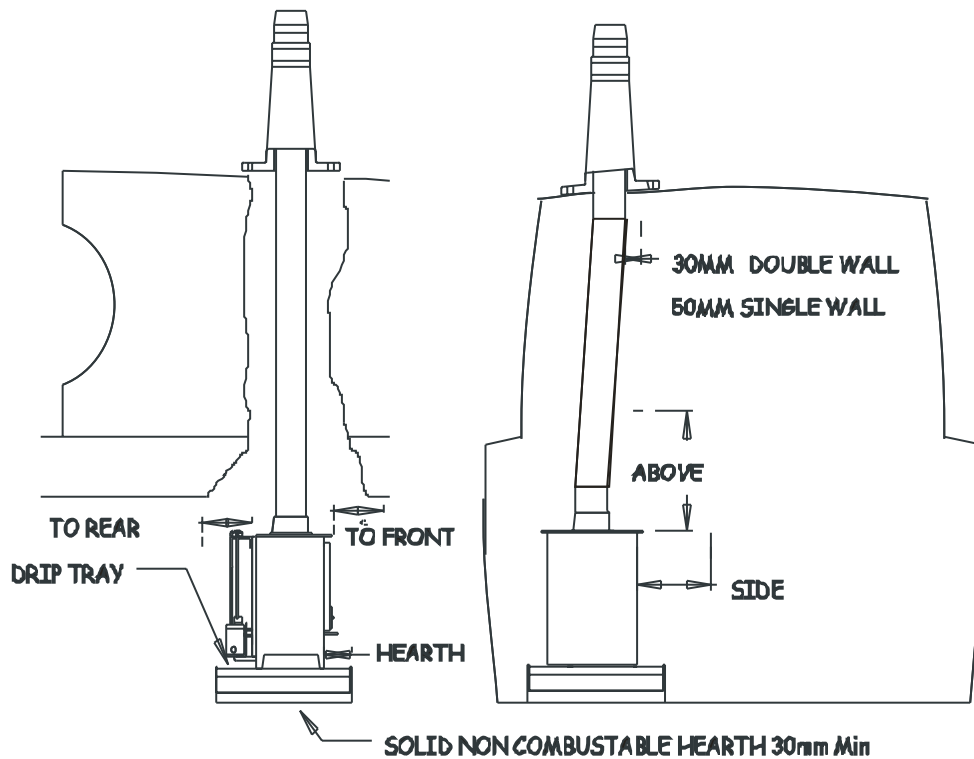

FIG 2 BUBBLE FABRICATED DECK FLANGE LAYOUT

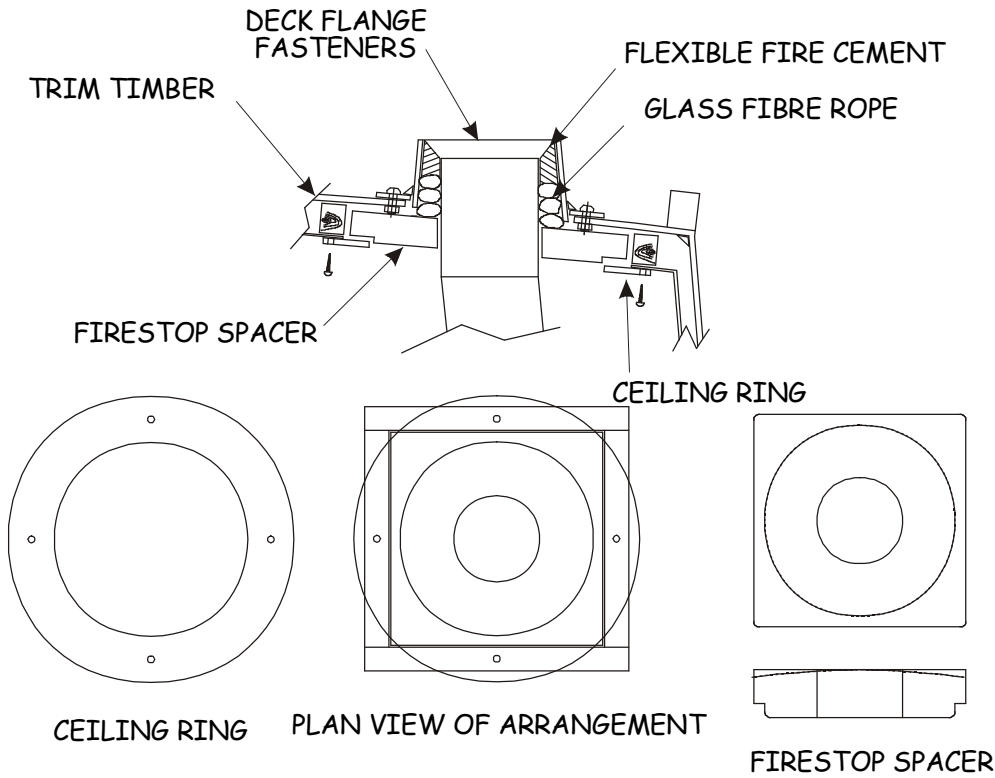

FIG 3 TYPICAL OIL FEED LAYOUT

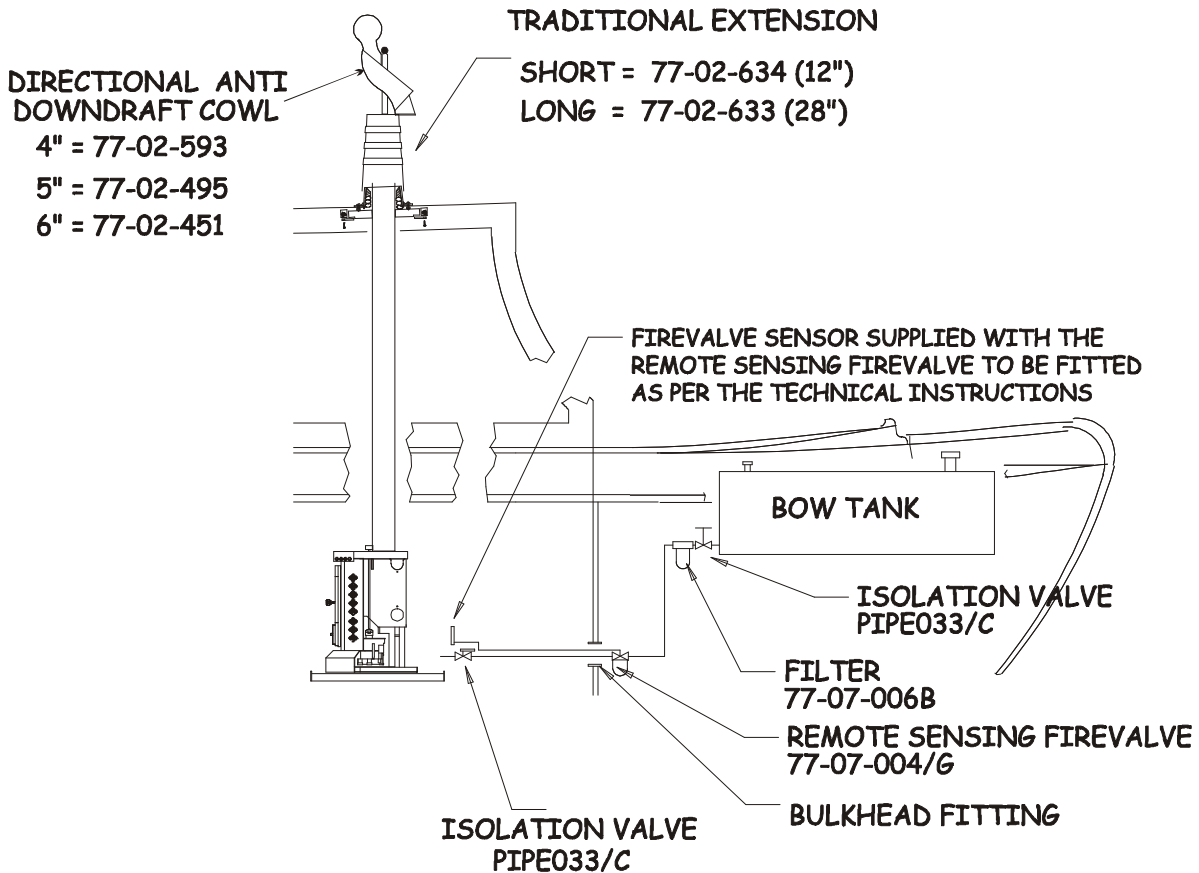
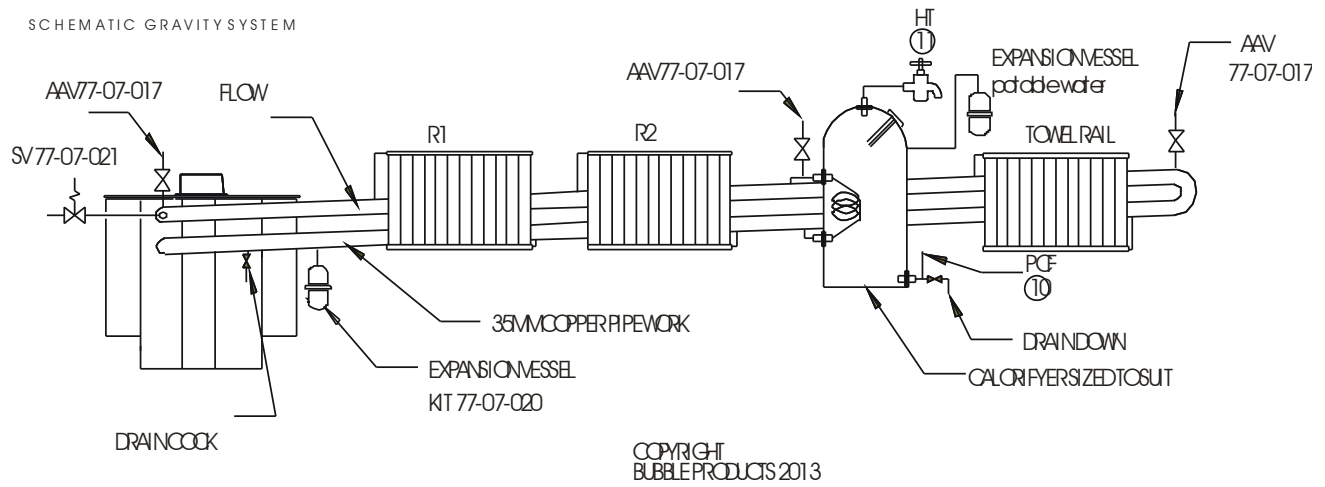
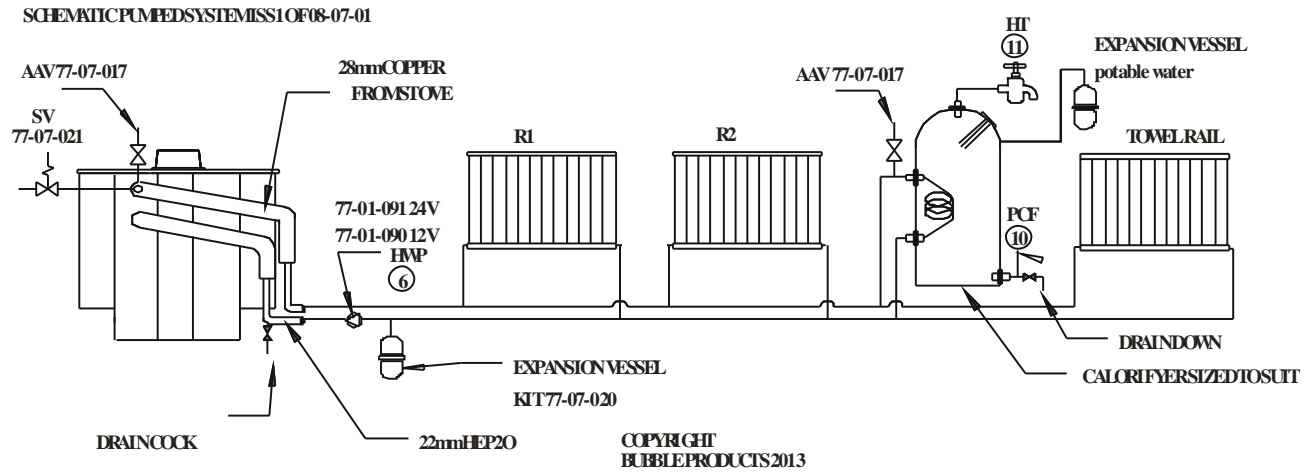

FIG 4 TYPICAL PUMBING LAYOUTS

Drq 1



Drq 2



Drq 3

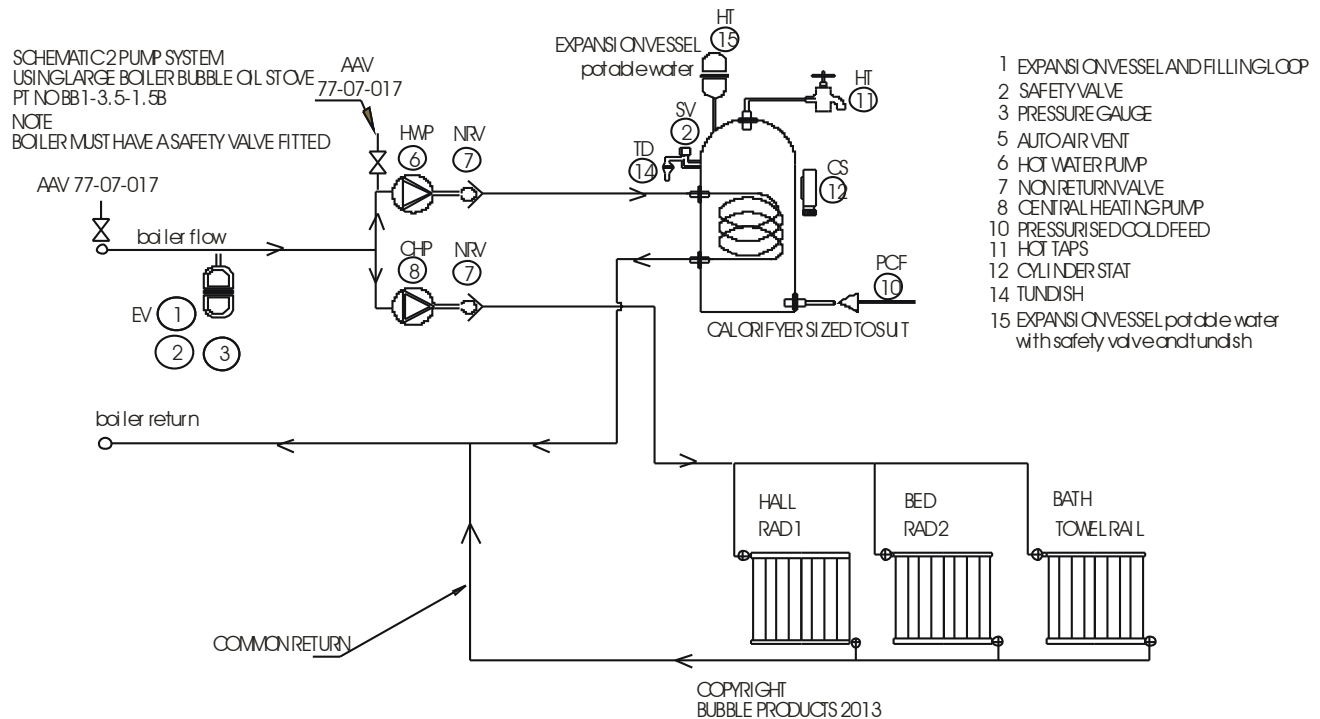

© HARWORTH HEATING LTD 30.6.98

This publication may not be copied by any means, without written permission from the authors.

These products are subject to continuous development and improvement and it is consequently acknowledged that due to this process there may be some omissions and errors.

This publication is intended only to assist the reader in the use of this product and therefore Harworth Heating Ltd shall not be liable for any loss or damage whatsoever arising from the use of any information, error or omission found in this publication.

The appliances mentioned in this publication can only be installed and serviced by approved personnel.

Approved personnel means that they must HAVE BEEN SUITABLY TRAINED.

For details of suitable training courses contact :-
www.oftec.org

6. NORMATIVE REFERENCES

Boat installation work comes under the control of:-

The Boat Safety Scheme.

This scheme provides statutory requirements and associated EN / BS Standards for most aspects of installation work on boats.

Further information and a copy of the requirements can be obtained from:-

www.boatsafetyscheme.com

Where guidance for oil fired appliances is not readily available from the Boat safety Scheme publication, we then point out a list of standards which pertain to domestic installations and which are generally covered by the latest version of the English Building Regulations Doc J.

When read in conjunction with :-

1. Our installation instructions.
2. The Boat Safety Scheme rules.
3. The other standards detailed, enough information should be provided to allow for a safe installation.

BS 5440	Flues.
BS 6999	Flues
BS 7840	Fuel Hoses.
BS EN1057	Copper Tubes.
BS1344 Part 3 1988 ISO8290 1987	Flues.
BS EN 1443:2003	Chimneys - General requirements.
BS EN1856 part 1 replacing BS 4543	Flues.
BS EN1856 part 2 & BS 715 1993	Flues.

BS 1945: 1971	Stove door
BS EN 10296-1	Steel tubes
BS ISO 10088:2001	
BS EN ISO 9094-2003	
BS EN 10297-1	Steel tubes
BS EN 13384-1	Chimneys
BS EN 10088-1:2005	Stainless steels - Part 1: List of stainless steels

http://www.oilstoves.co.uk/webdocs/articles/Boat_Flue_Systems.pdf

http://www.oilstoves.co.uk/webdocs/technical/Bubble/Bubble_Corner_Oil_Installation_Instructions.pdf