

INSTALLATION & GENERAL INSTRUCTIONS



Silent Simplicity just for you!

MARINE OIL STOVES ©

ISSUE 15 @ 22-06-18

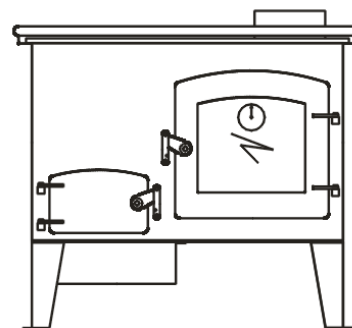
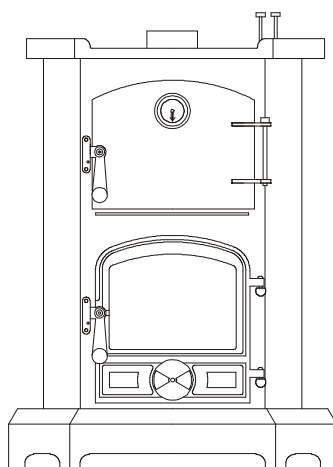
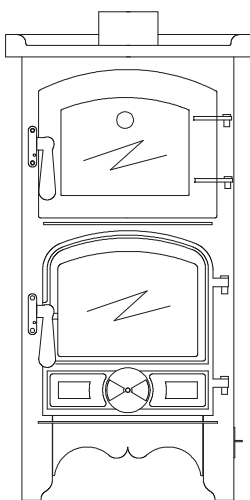
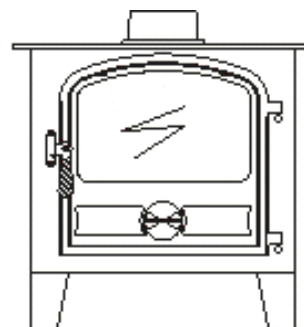
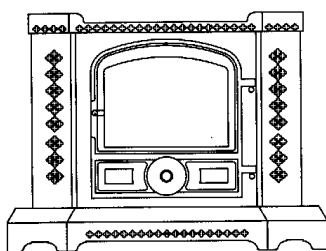
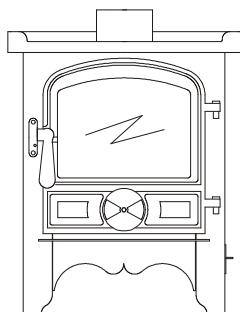

www.harworthheating.co.uk

INDEX

1. BEFORE STARTING THE JOB.	3
FITTING OPTIONS.	3
ABOUT THE APPLIANCES	3
2. SAFETY.	4
FUMES	4
FIRE	4
BURNS	4
CLEARANCES FROM COMBUSTIBLES	4
CLEARANCES FROM COMBUSTIBLES-FLUE PIPES	5
VENTILATION.	5
FLOODED VAPOURIZING BURNER POTS.	5
SECURELY FIX THE APPLIANCE	5
3. CHIMNEY	5
THE HEIGHT.	5
THE DIAMETER.	5
THE TEMPERATURE OF THE GASSES IN IT.	5
THE RESISTANCE OF THE INNER SURFACE OF THE FLUE PIPE OR PIPES.	5
THE TYPE OF TERMINAL.	5
THE PREVAILING ATMOSPHERIC CONDITIONS.	5
THE CHIMNEY RULES.	6
4. FUEL SUPPLY.	6
WAXING	6
AIR LOCKS	6
TRIM	6
TANK	6
OIL LINE	6
WATER CONTAMINATION	6
REMOTE SENSING FIREVALVES	7
ISOLATION VALVES.	7
SLEEVING.	7
OVERBOIL OR OVERHEAT PROTECTION OF THE APPLIANCE.	7
4A LIGHTING & COMMISSIONING	7
1. LIGHTING B1 HALF POD, B1 PIE POD AND B2	7
COMMISSIONING THE HIGH & LOW FIRE, CHRYSTAL SERIES	8
4B LIGHTING & COMMISSIONING THE BURNER SOCOMEF SERIES	9
1. LIGHTING CORNER STOVE, CORNER POD AND BACK CABIN COOKER.	9
COMMISSIONING THE HIGH AND LOW FIRE SOCOMEF BURNERS.	10
5. FIREPLACE.	10
6. DISTANCES FROM COMBUSTIBLES (APPLIANCES)	11
7. DISTANCES FROM NON COMBUSTIBLES (APPLIANCES)	11
8. DISTANCES FROM COMBUSTIBLES (FLUE PIPES)	11
9. ILLUSTRATIONS	12
FIG 1. STOVE DISTANCE FROM COMBUSTIBLES	12
FIG 2 BUBBLE MK1 FABRICATED DECK FLANGE LAYOUT	12
FIG 3 TYPICAL OIL FEED LAYOUT	13
FIG 4 TYPICAL PUMBING LAYOUTS	13
10. STOVE DIMENSIONS	14
10-1 BB1 HALF POD AND PIE POD DIMENSIONS	14
10-2 CORNER STOVE AND CORNER PIE POD DIMENSIONS	15
10-3 B2 STOVE DIMENSIONS	15
10-4 BACK CABIN COOKER DIMENSIONS	16
12. NORMATIVE REFERENCES	18

If you have any difficulties please phone our technical help line on-:

01302 742520 fax 01302 750573

e-mail contact@bubbleproducts.co.uk

<http://www.bubbleproducts.co.uk>

1. BEFORE STARTING THE JOB.

THE FOLLOWING NOTES PROVIDE INFORMATION FOR INSTALLATION OF THE FOLLOWING APPLIANCES.

Boat Bubble No 1 AND HALF POD, Dry Small and Large Boiler Appliances

Boat Bubble No 2 Dry Small and Large Boiler Appliances

Marine Corner Bubble Wet and Dry appliances

Bubble No 1 Cooking Stove plus boiler options.

Corner Cooking Stove plus boiler options.

Back Cabin Oil Fired Cooker.

FITTING OPTIONS.

There are normally two different situations that the installer may be faced with:-

1. A new build installation.

An established boat installation, (which has not had oil stove fitted).

2. A replacement installation, where there has been a solid fuel stove fitted previously.

Each of the situations will present differing problems which will be:-

- Where to locate the stove.
- How to deal with fireplace design.
- Where to locate the oil tank.
- How to get an oil supply to the stove.
- How to fit the chimney.
- How to connect water to the stove.
- How to disconnect and remove the stove, easily.

The new build situation should be the easiest.

The established boat situation will require careful attention to the sighting of the stove in relation to flue positions and existing fittings positions.

In replacement situations it may well be necessary to blank off the existing through roof flue position and cut a fresh one to suit the new location and comply with our instructions on flue design.

ABOUT THE APPLIANCES

Generally described as a space heater or space heater and cooker, which burns diesel oil in a controlled

manner utilizing a chimney to discharge the products of combustion.

The appliance generates heat from burning oil mixed with air in a vaporizing pot located in the bottom of the stove.

Once the appliance has been ignited, oil goes into the pot at a steady and controlled rate via a gravity feed which is metered by the OIL CONTROL VALVE; the oil flow can be controlled from minimum to maximum or any setting in between determined by the set position of the oil flow control knob.

Air is sucked into the pot by the natural action of the negative pressure in the chimney.

To allow the chimney to work correctly it is essential that you have adequate, unrestricted ventilation into the area where the stove is situated.

The amount of oil that can be successfully burned is directly proportional to the amount of air that the chimney can draw into the pot and so to achieve adequate combustion a balanced and appropriate flow of both oil and air is required.

The stove will provide space or combined space and water heating and in some cases cooking as well.

Where cooking and water heating are combined one feature will inevitably effect the other.

There are different versions of each appliance within the total range.

Some of the appliances are supplied as Dry, Small Boiler and Large Boiler versions namely B1 Half Pod, B1 Oven and B2.

Some of the appliances are supplied just as Dry and Large Boiler versions namely Corner Stove and Corner Oven Stove.

The Back Cabin Cooker can be supplied with or without a small boiler for domestic hot water heating only.(1kw)

All of the boilers are high water content and suitable for pumped or gravity systems and pressurised or open vented systems ASSUMING THAT THEY ARE INSTALLED BY SUITABLY QUALIFIED PERSONS.

All the appliances are fitted with a descaling device which should be rotated on a two weekly cycle to descale the oil inlet pipe.

Where applicable, appliances must not be operated with the glass front door opened or cracked, or without the lighting port plug fitted.

Where applicable, the door glass may require light cleaning occasionally depending upon the continuous running time of the stove.

Appliances must be securely bolted down to resist impact or collision and must be level in both directions.

All the appliances are supplied with clamp down brackets except the Back Cabin Cooker which must be fastened down through the foot plates.

The top of the appliances can be used for warming and cooking.

The oven appliances have a comprehensive range of cooking facilities with both oven and hot plate cooking available.

Some appliances can also be supplied with a coal kit, which just like a solid fuel stove, coal effect will only be available when the stove is running at maximum or near maximum performance.

Suitable deck flanges, flue systems and anti-downdraft cowls must be used.

CONTROLS

The output of the stove is regulated by the amount of oil allowed to go into it and this function is controlled by the -:

OIL CONTROL VALVE (O.C.V.), Turning the knob anti clockwise controls the oil flow.

2. SAFETY.

Take care to make sure that all safety and ventilation issues are adequately addressed.

FUMES

Always fit a suitable Smoke and Carbon Monoxide alarm within 1.5meters of the appliance.

Make sure that the function is checked on regular basis. (weekly)

Make sure that the alarm can be heard in the sleeping quarters.

Here are the main causes of fume or smoke to leak from the stove.

- The chimney is blocked.
- There are too many bends in the chimney.
- The above deck chimney extension is not high enough.
- The boat is moored in a position near to high buildings or trees and downdraughting is occurring.
- The chimney or parts of it are not airtight.

- There are unusually strong cross winds.

If down draughting occurs turn the appliance off until the winds subside and do not attempt to re-ignite the appliance until it has completely cooled down.

When it has cooled down, before attempting to ignite the appliance remove the catalyser and examine the base of the pot to make sure that there is no oil left in the pot, if there are signs of oil in the pot do not attempt to ignite the appliance until it has been completely dried out.

FIRE

Fire can be caused by a variety of potential danger points and because of the space limitation on boats; this risk is ever present and must be adequately assessed.

The main danger is the effects of heat from the stove on combustible materials and boat occupants.

Make sure that all combustibles are adequately protected from the effects of heat radiation.

Appliances must stand on a fireproof base of minimum thickness 30mm or a purpose made stand.

Floors in front of the stove must have suitable fire protection.

Built in stove heat shields should not be removed under any circumstances.

BURNS

During normal, day-to-day use, many parts of the stove, pipe work, and chimney will become too hot to touch.

Hot surfaces must be adequately protected to prevent anyone falling on to, or touching them.

Suitable fireguards for the appliance and chimney must be fitted.

Fireguards must comply with BS6539.

Always use heatproof gloves when working on or near to a hot stove.

CLEARANCES FROM COMBUSTIBLES

The appliances must be fitted in line with the distances specified in the tables.

All hearths and fireplaces must be made from non-combustible materials and adequately designed for the job.

CLEARANCES FROM COMBUSTIBLES-FLUE PIPES

Flue pipes must be fitted in line with the distances specified in the table and must be suitable for the individual application.

Any combustible materials within the specified distances from the appliances must be protected by a suitable heat shield.

Protection can be gained by the use of -:

- Sheet metal heat shields and spacers.
- Heat resistant boards such as TAC board.
Combustible materials can be-:
- Wooden furniture.
- Curtains.
- Wooden panels or frames adjacent to the flue pipe or where it passes through the deck of the boat.
- Carpet or flooring close to the stove.
- Items near to the stove, which could fall onto it and ignite, should the boat suffer a slight impact or collision.

VENTILATION.

Ventilation plays a vital role in the fitting and sighting of any stove.

The provision of ventilation for these appliances is adequately covered by the requirements of the boat safety scheme.

25cm sq. minimum permanent ventilation, directly to outside air, must be provided.

FLOODED VAPOURIZING BURNER POTS.

When attempting to light any of the appliances, make sure that the pot is not flooded with oil by looking into the base of the burner.

If it is flooded remove the excess oil.

Never try to relight a hot stove; wait until it has cooled down.

Hot oil vapour is explosive.

Never try to light a flooded pot.

SECURELY FIX THE APPLIANCE

The stove must be securely fastened down so that it can resist impact or collision and it must be level in both directions.

Level the stove in both directions when the vessel is midway between its maximum and minimum trim conditions.

Bubble appliances must not be fitted if the maximum angle of trim exceeds 0.75 deg forward to aft or port to starboard.

Only suitably qualified persons can install unvented plumbing systems.

A suitable and serviceable fire extinguisher should always be readily accessible.

3. CHIMNEY

This is the one of the most interesting problems the installer has to deal with and as the chimney affects most aspects of running the stove, we take time here to list the following information for your consideration.

The power, (*suck or vacuum the chimney can develop*) depends upon the following-:

THE HEIGHT.

THE DIAMETER.

THE TEMPERATURE OF THE GASSES IN IT.

THE RESISTANCE OF THE INNER SURFACE OF THE FLUE PIPE OR PIPES.

THE TYPE OF TERMINAL.

THE PREVAILING ATMOSPHERIC CONDITIONS.

It is obvious that on a boat all the above elements are in short supply.

Normally, we have low flues which are small in diameter and generally not very well insulated, coupled with all these problems we have another one, which is that the boat moves across constantly changing surroundings, through locks, into headwinds and crosswinds, all creating major opportunity for down draughting to occur.

Any bend in any part of the chimney or roughness on the internal chimney wall will slow down the velocity of rising gases and reduce the effectiveness of the chimney.

Any slight reduction in the flue gas temperature will reduce the chimney vacuum or pull, hence when the stove is slowed down for all night burning, as the flue gas cools down the chimney vacuum reduces and as the chimney vacuum drops, the stove may well start to burn sooty. This problem is highlighted even more during very cold weather when the chimney can cool down even faster. In these situations careful attention to servicing and low fire setting is essential.

THE CHIMNEY RULES.

1. Always use a top outlet for flue pipe take off.
2. Always try to get the stove as low as possible in the boat, this will allow installation of maximum length flue pipe.
3. Clean or have the chimney cleaned regularly. (Frequency depends upon type of fuel and length of time used).

4. FUEL SUPPLY.

There are several problems relating to diesel fuel supply, which need be adequately addressed.

WAXING

Cold weather waxing or thickening alters the flow characteristics of diesel.

An adequate fuel feed supply can turn into an inadequate one when the temperature starts to fall.

The worst scenario is fuel feed pipe 50-60 feet long in 8mm dia pipe.

The best-case scenario is a fuel pipe 4 feet long in 10mm dia with insulated lagging.

AIR LOCKS

Air lock in oil feed pipe work must be avoided.

The pipe work must slope down to the appliance and be clipped level at 500mm intervals to prevent sagging.

Any rises in the pipe work will cause air locks on commissioning and after future oil run out situations, if it is not possible to run the pipe work in a steady slope then where changes occur a vertical venting leg should be fitted.

TRIM

Bubble appliances must not be fitted if the maximum angle of trim exceeds 0.75 deg forward to aft or port to starboard.

Level the stove in both directions when the vessel is midway between its maximum and minimum trim conditions.

A minimum pressure head of 254mm (10") is required.

This head is measured from the base of the oil tank to the top of the oil control valve. In some cases this head can be affected by the ballast or trim of the boat.

Take great care to try out all the different ballast and trim possibilities to make sure that adequate oil feed is always available at the outlet end of the fuel pipe before it enters the oil control valve at the stove.

TANK

If the stove is fitted at the bow of the boat, a bow tank is recommended.

The tank should comply with the requirements of the boat safety scheme and have:-

- A conveniently sized filler
- A means of venting.
- A conveniently located, easily visible, contents gauge.
- An isolation valve
- An easily replaceable cartridge filter.
- A suitable and substantial water trap

Do not use glass filter bowls, they are not acceptable under the boat safety scheme.

Make sure that your fuel supplier supplies you with appropriate fuel for wintertime running.

OIL LINE

The oil feed line starts after the fuel filter and proceeds to the point of entry, which is where the oil line goes into the cab or saloon of the boat.

The diameter of the oil line is dependent upon the length of run. See 3-2 on waxing and make sure that you have suitably sized compression fittings available.

At this point it is necessary to fit a 60 DEG C, remote sensing fire valve, designed to shut off the oil supply, should a fire occur near to the stove.

If the bubble stove is fitted up to the first bulkhead it will be necessary to fit the isolation valve outside the cabin or saloon of the boat. 5. Make sure that you have purged the oil feed line of all air and there is a steady and constant flow of oil available at the inlet to the oil valve. Make sure that all or any oil isolation devices are turned to the on position. Remember that the oil valve needs a min head of 300mm for gravity feed. When feeding from rear tanks with appliances fitted forward always be aware of the forward - aft trim of the vessel.

Do not use syphonic oil feeds to Bubble Appliances, oil should be fed by gravity or pumped via an appropriate pressure pump = head pressure less than 99mbar.

WATER CONTAMINATION

Because of the high risk of fuel contamination with water, we strongly recommend the fitting of a **high volume water trap**, in the oil supply line.

REMOTE SENSING FIREVALVES

There are two situations where a remote sensing firevalve should be fitted.

1. For fire protection fit a 60 deg C valve.
2. For over boil protection fit an additional 90 deg C valve.

For fire protection a remote sensing fire valve should be fitted as detailed in fig 3.

Run the capillary tube with the oil line up to the stove and carefully fit the sensing phial as follows

B1 Half Pod, B1 Oven and B2 at a low level fitted on two 15mm pipe clips.

Corner Stove and Corner Oven Stove on 15mm pipe clips in front of the drip tray on the fireplace hearth, directly in front of the combustion air restrictor.

Before it is fitted try the fender on the stove to make sure that the fender does not foul the sensing phial.

The sensing phial may be visible through the bottom of the fender, to mask it, paint it with matt black paint available from our sales desk.

When fitting the fire valve make sure that where the capillary and oil line go through the bulkhead in separate sleeved tubes, so that the capillary can be withdrawn separately should it ever need replacing.

For fitting of long oil feed lines which pass through bulkheads and various other parts of the boat it may well be necessary to fit more than one fire valve, especially where the oil line passes through an area where a fire could occur i.e. kitchen area etc.

ISOLATION VALVES.

Two isolation valves are required, one fitted directly into or close to the oil control valve to allow you or the service man to turn the oil off should the need arise, and one fitted directly into the oil tank before the fuel filter.

Always turn off the oil isolation valve serving the appliance before leaving the vessel unattended.

SLEEVING.

Where the oil line goes through the boat superstructure a suitable bulkhead fitting must be used.

OVERBOIL OR OVERHEAT PROTECTION OF THE APPLIANCE.

Where appliances are not fitted with an automatic thermostat an additional 90 DEG C, remote sensing

fire valve must be fitted directly in front of the oil control valve and the sensor from this valve has to be attached to the water jacket or the hot outlet pipe from the boiler.

The valve is calibrated to shut the oil supply down should the water temperature exceed 90 Deg C.

There is a re set button on the remote sensing fire valve which needs to be pressed in to re set the valve after it has tripped off.

4A LIGHTING & COMMISSIONING

A relevant oil control valve catalogue is supplied with each appliance and details of high and low fire adjusting screws are illustrated.

On the Toby valve the low fire screw is clearly visible as per TOBY MANUAL FIG 2

Before trying to light the burner in cold weather it is advisable to pre heat the flue pipe before lighting.

There are two different types of burner fitted to Bubble appliances.

The FB style burner fitted to the **B1 Half Pod, B1 Pie Pod and B2.**

The Socomef burner fitted to the **Corner Stove, Corner Oven Stove** and the **Back Cabin Cooker see sec 4B for lighting Socomef burners.**

1. LIGHTING B1 HALF POD, B1 PIE POD AND B2

When attempting to light the stove these are the rules, which must be followed.

1. Always make sure that the pot is **not** flooded with oil by looking down into the base of the pot.
2. Never try to light the stove if it is flooded with oil.
3. Always check that oil has not leaked from the appliance.
4. Do not light the stove and leave it unattended until it is settled down and stabilized into constant blue flame combustion on low fire. (This could take 10 to 20 minutes.)

On first light up it is advisable to warm the flue pipe up to try and create chimney draft.

Two Ways to Light the Stove

1. Through the lighting port B1 and B2 appliances only,
or
2. Directly into the base of the pot by removing the catalyser.

Lighting into the base of the Pot

On the first light up you may find this option better, as it is possible to see the oil trickle in to the pot more easily.

Use a heatproof glove when putting the catalysers back into the pot and it is important to replace them quickly whilst the flame is small.

Make sure that the oil is turned off.

Open the front door.

Remove the optional coal kit if fitted.

Remove the catalyser.

Turn the oil on and allow a small pool of oil to flow into the pot about the size of a small biscuit, **then turn the oil off.**

Note that on first light up it may take a few minutes for the oil to reach the pot as it has to fill the pipework before reaching the pot, take care not to allow excess oil to flow into the pot.

Light a small piece of firelighter and drop it into the oil, allow a few seconds for it to get going and then replace the catalyser and coal kit if fitted, and close the door.

Wait for approx. 1 minute until the pool of oil is alight and then **turn the oil on** to minimum setting no 1.

Watch the appliance for a few minutes and you will see the flame establish and settle down into blue flame combustion.

Allow the burner to run for a further 10 minutes before turning the appliance up to the higher settings.

If at any time during the ignition process large amounts of flame can be seen, turn the oil off immediately and wait until the flames die down before putting the oil on again at minimum setting.

Manual Lighting through the Lighting Port B1 and B2 appliances.

Check that the isolation valve is turned on.

Open the front door.

Remove the front apron on B1 Half Pod and B1 pie Pod.

Remove the lighting port plug by pulling it out of its tubular socket.

Turn the oil on to the first position via the flow control knob and allow a small pool of oil to flow into the pot about the size of a small biscuit.

Turn the oil off.

Cut a small piece of firelighter and stab it onto the spike.

Light it and push it into the lighting port tube, let the firelighter drop off the spike into the bottom of the pot.

Replace the lighting port plug back into the tube.

Close the front door.

Turn the fuel flow on again at the lowest setting

Watch the appliance for a few minutes until it settles down into blue flame combustion.

Allow the burner to run for a further 10 minutes before turning the appliance up to the higher settings.

If at any time during the ignition process large amounts of flame can be seen, turn the oil off immediately and wait until they die down before putting the oil on again.

Note there may be the occasional growl or audible vibration whilst the burner settles down into blue flame combustion.

COMMISSIONING THE HIGH & LOW FIRE, CHRYSTAL SERIES

Used in B1 Half Pod, B1 Pie Pod and B2

When the burner has established good blue flame combustion turn it up to half output. (Setting 3 on the fuel flow control knob) and let it stabilize.

Allow at least half an hour for the chimney to warm up thoroughly before making any adjustments to the high or low fire screws.

Turn the stove down onto minimum firing rate and let it stabilize.

After stabilization there should be a dull red glow in the lower catalyser with wispy blue flames flicking into and just over it.

If the flame falls into a dirty rolling yellow flame and the catalyser is not dull red then the low fire will need to be increased until it can support the required blue flame combustion.

To increase the low fire oil flow, screw the adjusting screw out by quarter turn increments.

When you are happy with the low fire, set the high fire.

Turn the oil flow knob up to setting 4, let the flame stabilize, and look at it, if it is stable and blue, turn it up slowly using the control knob, letting it stabilize after each movement, if the flame starts to go yellow with long flame combustion, it is running fuel rich and

the high fire screw needs adjusting to reduce the flow of oil. (Screw the adjuster screw in to reduce the high fire oil flow.)

Before adjusting the high fire screw, turn the flame down and let it stabilize in blue flame combustion, adjust the high fire screw by half a turn in and try turning the fuel flow up, if it is still fuel rich repeat the process until the high fire flame is running blue with just flicks of yellow in the tips.

To see a bubble stove running correctly see the following link

<https://www.youtube.com/watch?v=UqdQLFp3HkQ>

4B LIGHTING & COMMISSIONING THE BURNER SOCOMEF SERIES

1. LIGHTING CORNER STOVE, CORNER POD AND BACK CABIN COOKER.

When attempting to light the stove these are the rules, which must be followed.

1. Always make sure that the pot is not flooded with oil by looking down into the base of the pot.
2. Never try to light the stove if it is flooded with oil.
3. Always check that oil has not leaked from the appliance.
4. Do not light the stove and leave it unattended until it is settled down and stabilized into constant blue flame combustion on low fire. (This could take 10 to 20 minutes.)
5. Make sure that you have purged the oil feed line of all air and there is a steady and constant flow of oil available at the inlet to the oil valve. Make sure that all or any oil isolation devices are turned to the on position. Remember that the oil valve needs a min head of 300mm for gravity feed. When feeding from rear tanks with appliances fitted forward always be aware of the forward - aft trim of the vessel.
6. Do not use syphonic oil feeds to Bubble Appliances, oil should be fed by gravity or pumped via an appropriate pressure pump = head pressure less than 99mbar.

On first light up it is advisable to warm the flue pipe up to try and create chimney draft.

Lighting the Stove

Lighting the stove takes a little time and patience; the following procedure should be adopted.

In the case of the Corner appliances, open the front door and in the case of the Back Cabin Cooker remove the hot plate and top baffle to gain access to the

burner, note that the back cabin cooker has a lighting port fitted behind the lower ash pit door.

Remove the coal kit if it has been supplied with the stove.

Lift the inner mesh catalyser from the burner.



Look into the bottom of the pot and turn the oil on at full rate, allow oil to flow into the bottom of the pot to form a pool about the size of a small digestive biscuit and then turn the oil off.

Note that on first light up it may take a few minutes for the oil to reach the pot as it has to fill the pipework before reaching the pot.

Do not allow any depth of oil to build up.

Light a small piece of firelighter (about the size of a pineapple chunk) and place it into the centre of the oil pool.

Replace the mesh catalyser and the coal kit, if fitted and then leave the door slightly open whilst the firelighter gets the oil going.

After 30 to 40 seconds, you will notice the flame start to establish itself and spread around the bottom of the pot.

When this occurs, close the door or replace the baffle and top plate and then turn the oil on to its minimum setting.

After two or three minutes the flame should slowly change from yellow into blue flame combustion and settle down to a steady burn.

Note there may be the occasional growl or audible vibration whilst the burner settles down into blue flame combustion.

Allow the burner 10 - 15 minutes to stabilise and the increase the flow of oil as required, moving by one increment of the dial only.

Do not leave the appliance unattended during the lighting and stabilising procedure.

COMMISSIONING THE HIGH AND LOW FIRE SOCOMEF BURNERS.

Corner Stove, Corner Pod and Back Cabin Cooker.

Note that Back cabin Cookers are pre commissioned at the factory and do not need adjusting.

A relevant oil control valve catalogue is supplied with each appliance and details of high and low fire adjusting screws are illustrated.

On the Toby valve the low fire screw is clearly visible as per TOBY MANUAL FIG 2

When the burner has established good blue flame combustion turn it up to half output. (Setting 3 on the fuel flow control knob) and let it stabilize for a minute. Allow at least half an hour for the chimney to warm up thoroughly before making any adjustments to the high or low fire screws.

Turn the stove down onto minimum firing rate and again let it stabilize.

After stabilization there should be a dull red glow in the catalyser with wispy blue flames flickering just over the top of it, approximately level with the top of the pot.

If the flame falls into a dirty rolling yellow flame and the catalyser is not dull red then the low fire will need to be increased until the burner can support the required blue flame combustion.

When you are happy with the low fire, set the high fire.

Turn the oil flow knob up to setting 4, let the flame stabilize, and look at it, if it is stable and blue, turn it up slowly using the control knob, letting it stabilize after each movement, if the flame starts to go yellow with long flame combustion, it is running fuel rich and the high fire screw needs adjusting to reduce the flow of oil. (Screw the adjuster screw in to reduce the high fire oil flow.)

Before adjusting the high fire screw, turn the flame down and let it stabilize in blue flame combustion, adjust the high fire screw by half a turn in and try turning the fuel flow up, if it is still fuel rich repeat the process until the high fire flame is running blue with flicks of yellow in the tips.

On the Socomef pot, the high fire flame will be set approx. 40mm above the top of the pot.

NOTE THAT THIS PROCEDURE WILL NOT BE POSSIBLE IF THE CHIMNEY RULES HAVE NOT BEEN ADHERED TO.

THE HIGH FIRE SETTING WILL HAVE TO BE ADJUSTED IN LINE WITH THE AVAILABLE GENERATED CHIMNEY VACUUM IE

THE FLUE PIPE MUST BE A MINIMUM OF 1.8 METERS HIGH FOR LOW FIRE AND 2.1 METERS FOR HIGH FIRE.

INSTALLING ENGINEERS SHOULD NOT LEAVE THE APPLIANCE UNDER THE CONTROL OF THE CUSTOMER UNLESS THE APPLIANCE HAS BEEN CORRECTLY COMMISSIONED.

TO SEE HOW THE BURNER SHOULD OPERATE COMMISSIONING AND INSTALLING ENGINEERS SHOULD VISIT

<https://www.youtube.com/watch?v=UqdQLFp3HkQ>

This video shows a stove running from low to high fire and back to low fire. Note that this video is filmed on a normal house chimney and so it may not be possible to get exactly the same conditions on a typical boat flue as the fuel air ratio will not be exactly the same, hence the need for fine tuning the oil flow to the chimney air flow capability.

5. FIREPLACE.

Unless one is built into the appliance, always fit appliances on a suitable drip tray.

The possibility of oil drops leaking from the stove must be considered; a suitable oil drip tray must be fitted and designed in such a way, as it will contain any oil leaks or drips.

Normally the tray will cover the footprint of the stove, the oil valve and isolation device.

It will be oil tight and have a vertical up stand of at least 30mm. This should give a minimum containment volume of 2 litres.

It will be securely fastened down to the vessel and the appliance must be securely fastened down to the oil drip tray.

Make sure that drip trays are tested to ensure that they do not leak when filled with oil.

The hearth must be:-

FLAT - SECURE - FIREPROOF AND LEVEL IN BOTH DIRECTIONS.

Use materials, which are easy to keep clean and fireproof such as tiles, asbestolux or vermiculite boarding with a suitable weight resistant liner.

The vertical walls of the fireplace must also be made from fireproof materials.

Use fireproof, rockwool infill behind the fireplace panels to protect any combustible insulation materials

such as spray foam.

6. DISTANCES FROM COMBUSTIBLES (APPLIANCES)

Stove Type	ABOVE	SIDES.	BACK	FRONT	HEARTH Non Combustible Material
B1 HALF POD and OVEN VERSION	500	300	150 FROM HEAT SHIELD	300 to allow door opening.	30MM THICK x 100 projection at the front and sides
BOAT B2	600	300	150 FROM HEAT SHIELD	300 to allow door opening.	30MM THICK x 100 projection at the front and sides
CORNER and OVEN VERSION	500	75	100 FROM HEAT SHIELD	300 to allow door opening.	30MM THICK x 100 projection at the front.
BACK CABIN COOKER	500	150	100 FROM HEAT SHIELD	300 to allow door opening.	25MM THICK x 150 projection at sides

7. DISTANCES FROM NON COMBUSTIBLES (APPLIANCES)

Stove Type	ABOVE	SIDES.	BACK	FRONT	HEARTH Non Combustible Material
B1 HALF POD and OVEN VERSION	300	150	150 FROM HEAT SHIELD	300 to allow door opening.	30MM THICK x 100 projection at the front and sides.
BOAT B2	300	150	150 FROM HEAT SHIELD	300 to allow door opening.	30MM THICK x 100 projection at the front and sides.
CORNER and OVEN VERSION	200	150	25 FROM HEAT SHIELD	300 to allow door opening.	30MM THICK x 100 projection at the front and sides.
BACK CABIN COOKER	500	75	50 FROM HEAT SHIELD	300 to allow door opening.	25MM THICK x 75 projection at sides

Note that the back cabin cooker can have the oil control valve fitted to the rear or the left hand side in each case the positioning of the valve will affect the fireplace and spacing considerations, see sizes of cooker to establish requirements.

8. DISTANCES FROM COMBUSTIBLES (FLUE PIPES)

For all appliances-:

1. Single skin flue pipes. Horizontal Distance = 50mm **when fitted within the deck flange** at the top of the chimney system, protected by the fire stop spacer.
2. Single skin flue pipes. Horizontal Distance = 150mm **when exposed in the saloon or living space.**
3. Twin Wall Insulated flue pipes. Horizontal Distance = 30 mm for insulated flue pipe systems.

9. ILLUSTRATIONS

FIG 1. STOVE DISTANCE FROM COMBUSTIBLES

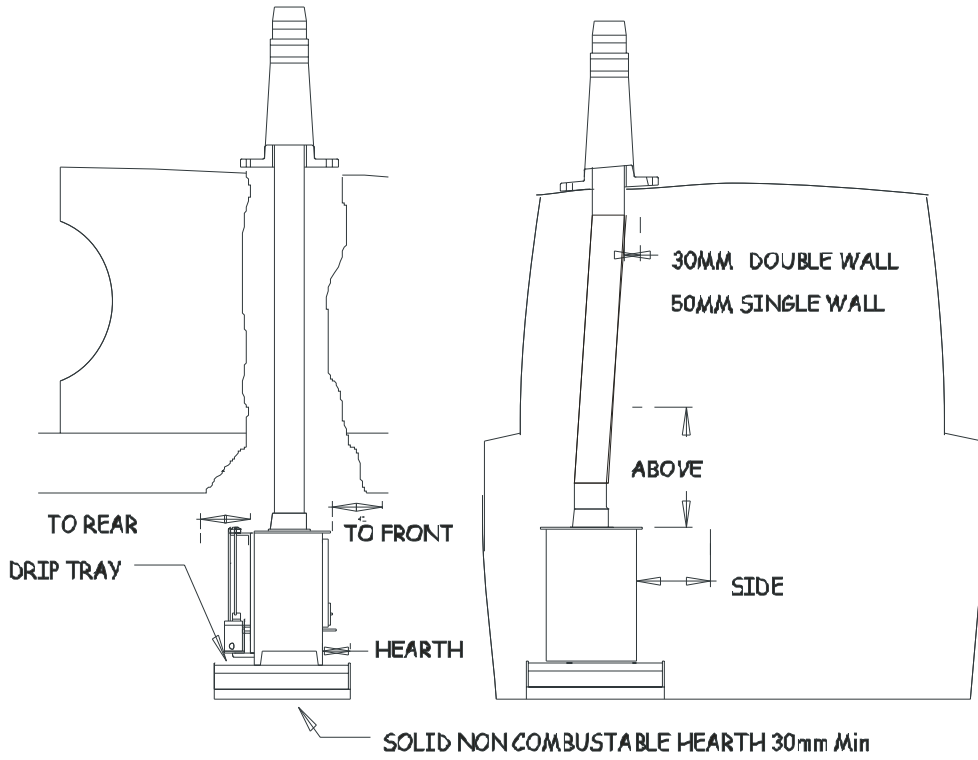

FIG 2 BUBBLE MK1 FABRICATED DECK FLANGE LAYOUT

Note that there is mk3 system which is now available and detailed on our web site.

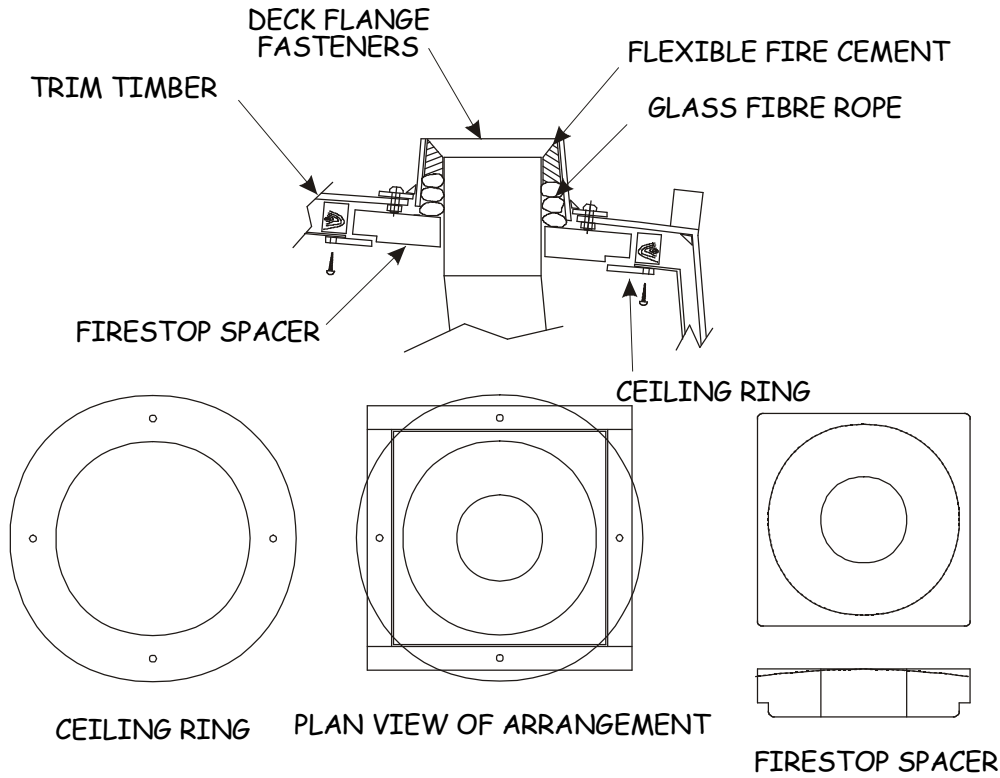
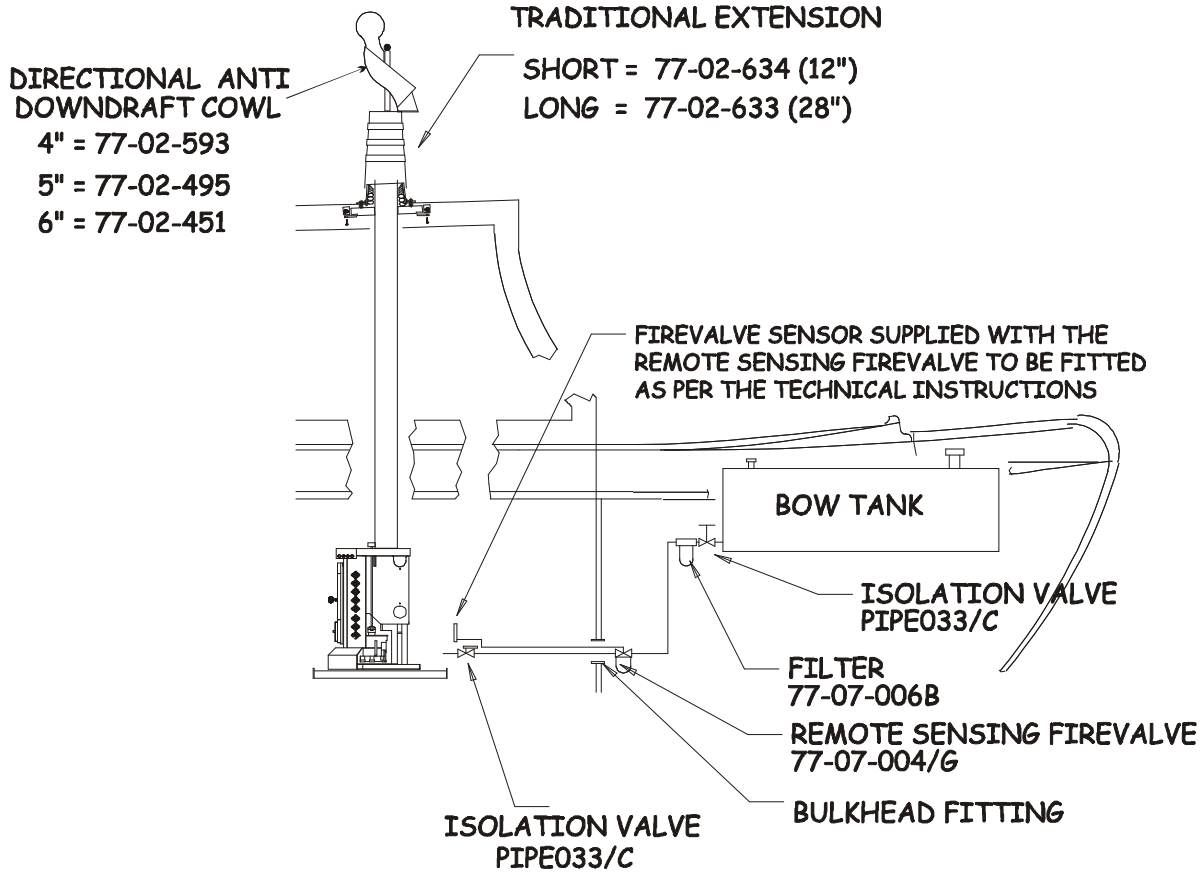

FIG 3 TYPICAL OIL FEED LAYOUT



COPYRIGHT HARWORTH HEATING LTD 080800

FIG 4 TYPICAL PUMING LAYOUTS

Drq 1

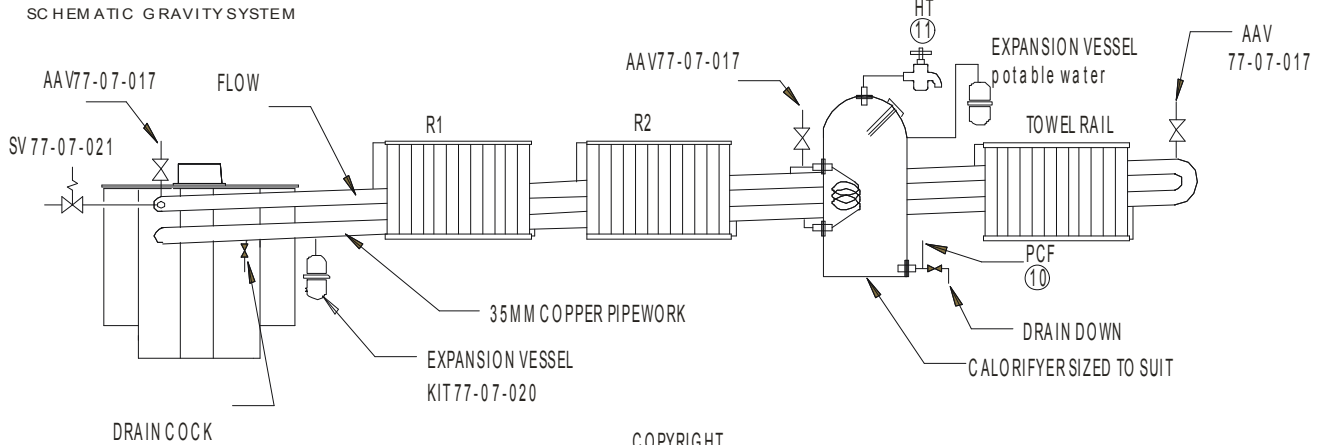

COPYRIGHT BUBBLE PRODUCTS 2013

Drg 2

SCHEMATIC PUMPED SYSTEM ISS 2 OF 28-10-17

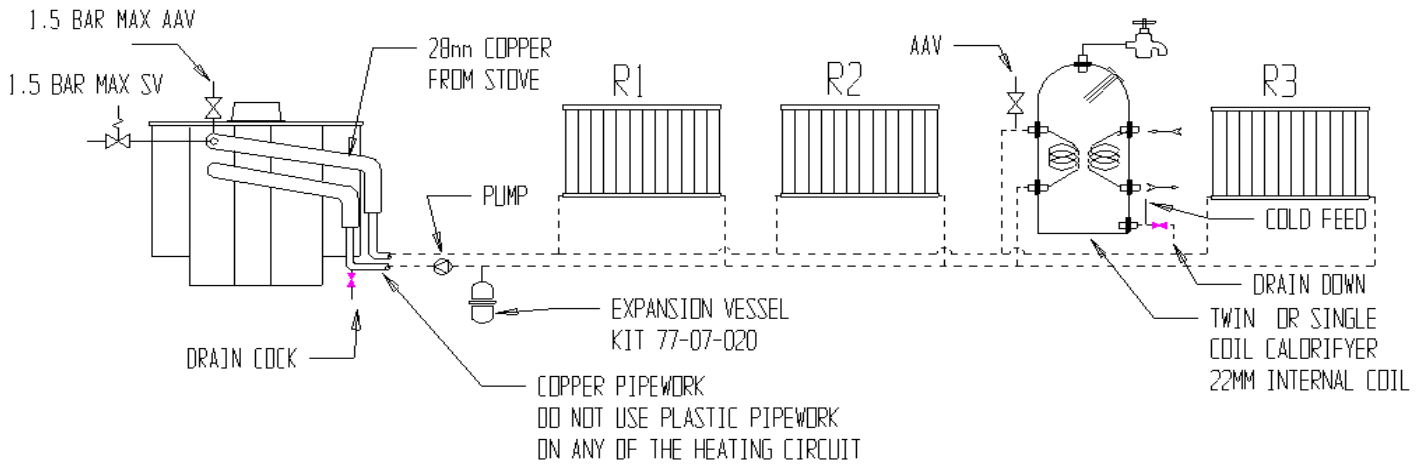

Drg 3

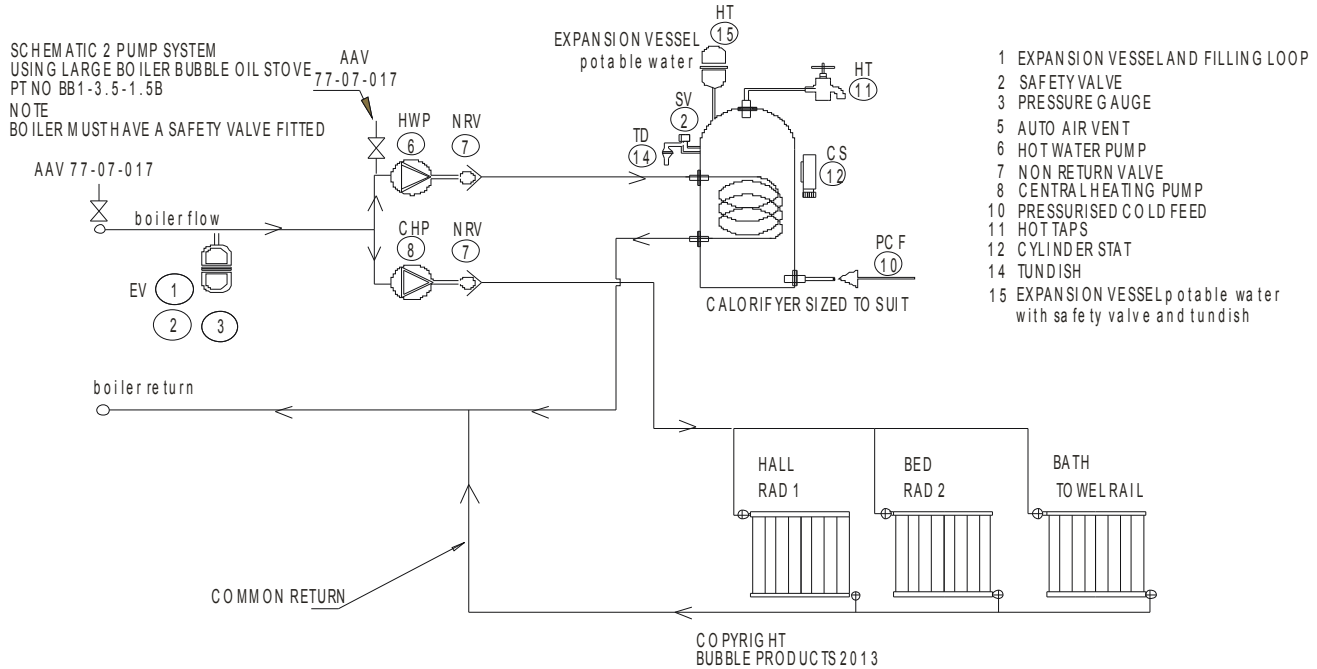

10. STOVE DIMENSIONS

10-1 BB1 HALF POD AND PIE POD DIMENSIONS

Note that the B1 Pie Pod has the same footprint dimensions but the vertical height is 830mm.

**B1 HALF OIL POD OF 12-02-15
OVERALL DIMENSIONS
BOILER AND NON BOILER VERSIONS**

**.WEIGHT 35 KG NON BOILER
.WEIGHT 45 KG SMALL BOILER
.WEIGHT 50 KG LARGE BOILER**

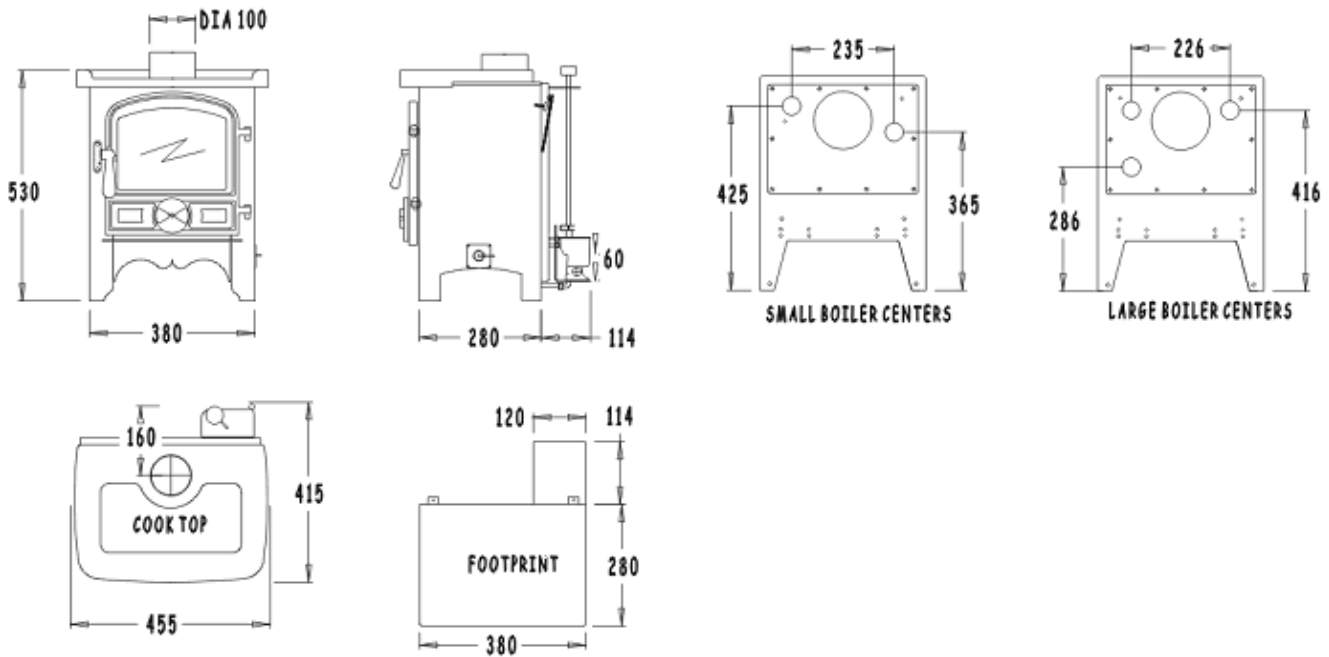

10-2 CORNER STOVE AND CORNER PIE POD DIMENSIONS

Note that the Corner Pie Pod has the same footprint dimensions but the vertical height is 840mm.

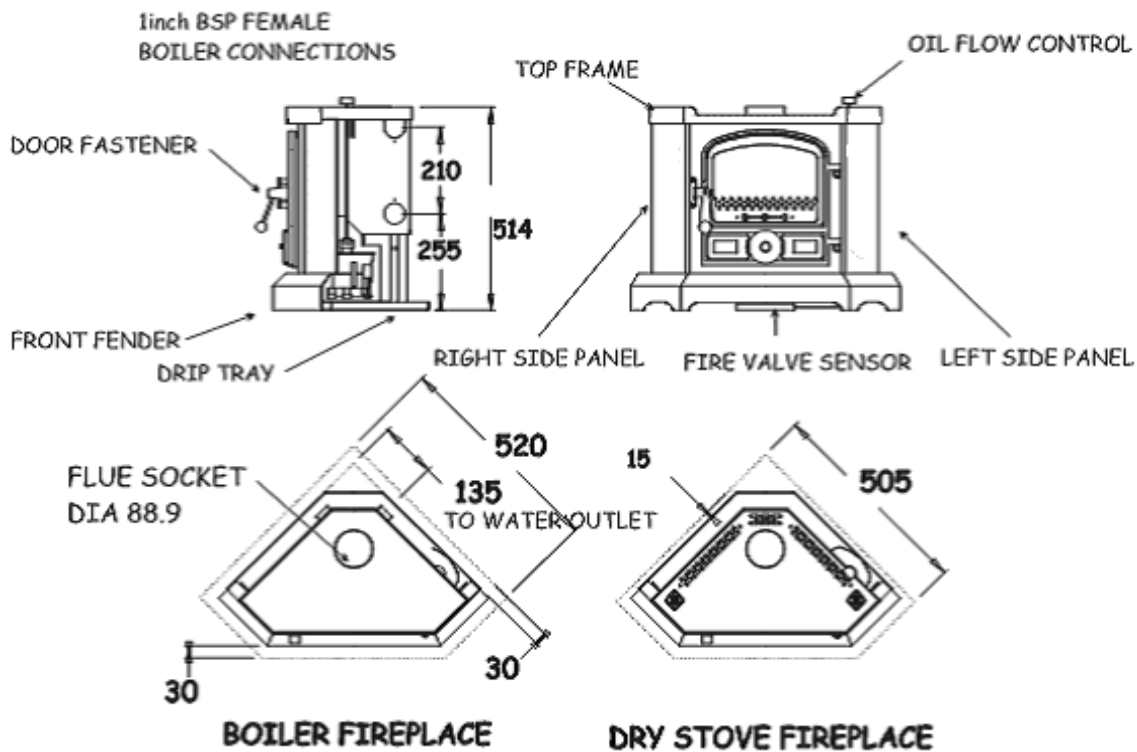

10-3 B2 STOVE DIMENSIONS

Note that the B2 Pie Pod has the same footprint dimensions but the vertical height is 830mm.

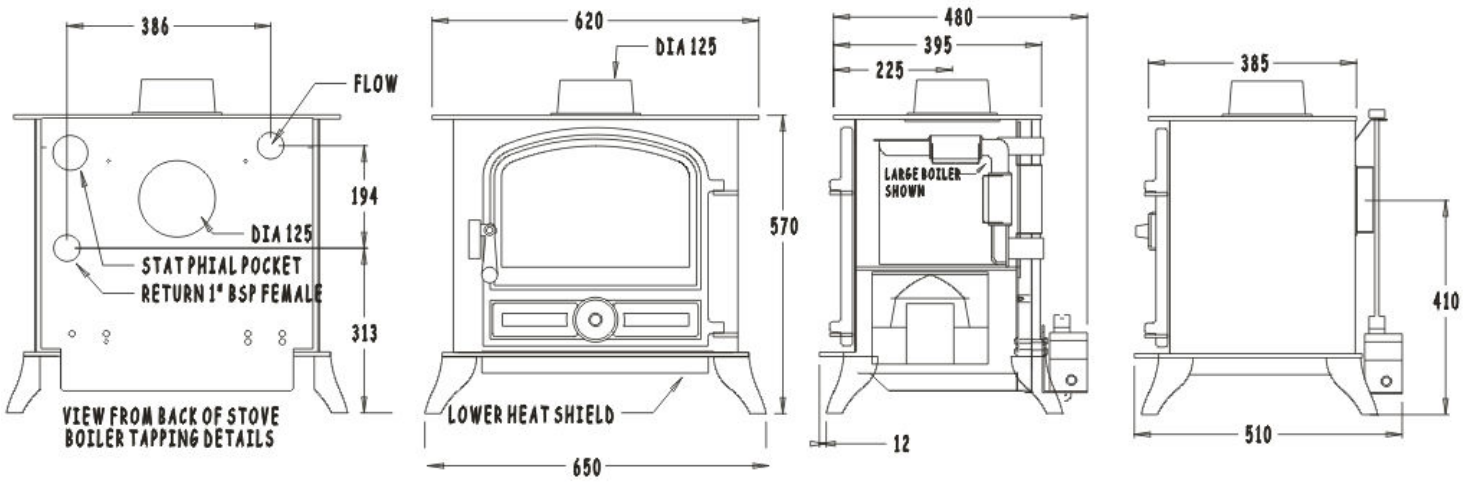

10-4 BACK CABIN COOKER DIMENSIONS

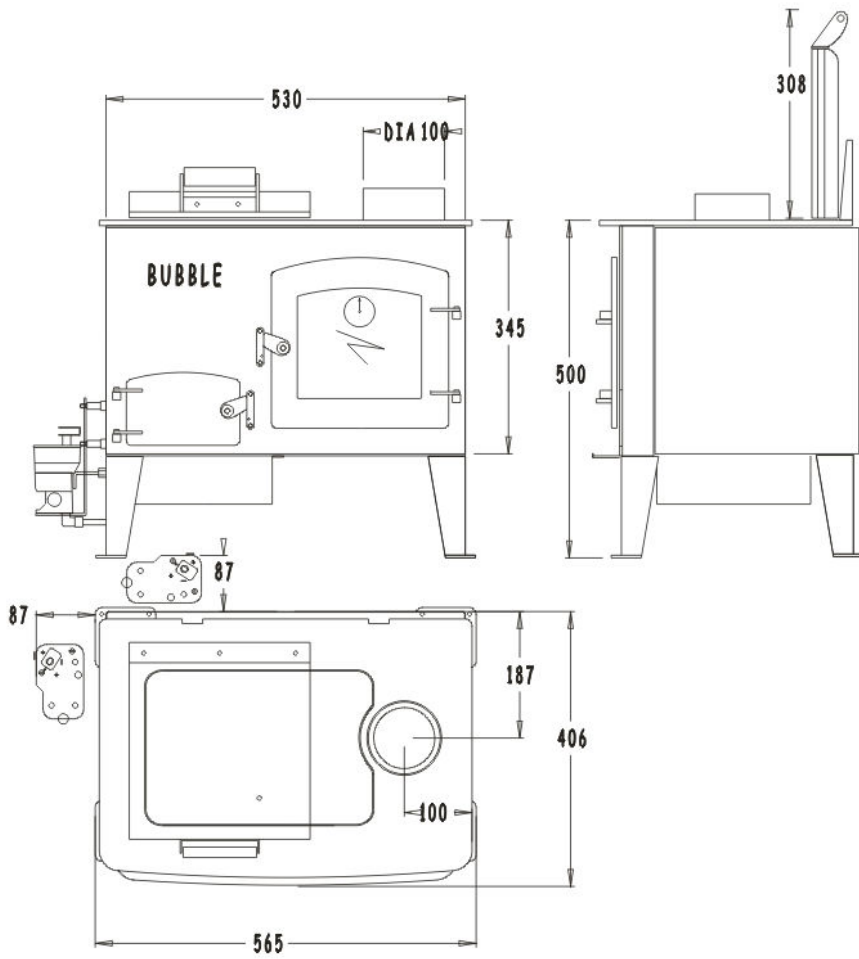

11. OIL CONSUMPTION RATES

		MAX HEAT OUTPUT TO WATER	MAX HEAT OUTPUT TO SPACE	MINIMUM OIL FLOW CC'S PER MIN	MAXIMUM OIL FLOW CC'S PER MINUTE
--	--	--------------------------	--------------------------	-------------------------------	----------------------------------

B1 HALF POD & OVEN DERIVATIVE

Free Standing	From 1.6kW to 5kW		5kW	4 = (1.6kW)	12 = (5kW)
Free Standing	From 1.6kW to 5kW	2kW	3kW	4 = (1.6kW)	12 = (5kW)
Free Standing	From 1.6kW to 6kW	5kW	2kW	4 = (1.6kW)	13 = (6kW)

CORNER STOVE & OVEN DERIVATIVE

Free Standing	From 1kW to 4kW		4kW	3 = (1kW)	10 = (4kW)
Free Standing	From 1kW to 4kW	3kW	1kW	3 = (1kW)	10 = (4kW)

BUBBLE 2

Free Standing	From 1.6kW to 5kW		5kW	4 = (1.6kW)	13 = (5kW)
Free Standing	From 1.6kW to 8kW		8kW	4 = (1.6kW)	16 = (8kW)
Free Standing	From 1.6kW to 8kW	3kW	5kW	4 = (1.6kW)	16 = (8kW)
Free Standing	From 1.6kW to 8kW	9kW	2kW	4 = (1.6kW)	22 = (11kW)

BACK CABIN COOKER

Free Standing	From 1.6kW to 5kW		3kW	4 = (1.6kW)	7 = (3kW)
Free Standing	From 1.6kW to 5kW	1kW	2kW	4 = (1.6kW)	7 = (3kW)

© HARWORTH HEATING LTD 30.6.98

This publication may not be copied by any means, without written permission from the authors.

These products are subject to continuous development and improvement and it is consequently acknowledged that due to this process there may be some omissions and errors.

This publication is intended only to assist the reader in the use of this product and therefore Harworth Heating Ltd shall not be liable for any loss or damage whatsoever arising from the use of any information, error or omission found in this publication.

The appliances mentioned in this publication can only be installed and serviced by approved personnel.

Approved personnel means that they must HAVE BEEN SUITABLY TRAINED, if there are any

reliability issues reported back to **Harworth Heating** or **Bubble Products**, the installing engineer will be responsible for carrying out any rectification work.

For details of suitable training courses contact: - www.oftec.org

12. NORMATIVE REFERENCES

Boat installation work comes under the control of: -
The Boat Safety Scheme.

This scheme provides statutory requirements and associated EN / BS Standards for most aspects of installation work on boats.

Further information and a copy of the requirements can be obtained from:-

www.boatsafetyScheme.com

Where guidance for oil fired appliances is not readily available from the Boat safety Scheme publication, we then point out a list of standards which pertain to domestic installations and which are generally covered by the latest version of the English Building Regulations Doc J.

When read in conjunction with:-

1. Our installation instructions.
2. The Boat Safety Scheme rules.
3. The other standards detailed, enough information should be provided to allow for a safe installation.

BS 5440	Flues.
BS 6999	Flues
BS 7840	Fuel Hoses.
BS EN1057	Copper Tubes.
BS1344 Part 3 1988 ISO8290 1987	Flues.
BS EN 1443:2003	Chimneys - General requirements.
BS EN1856 part 1 replacing BS 4543	Flues.
BS EN1856 part 2 & BS 715 1993	Flues.
BS 1945: 1971	Stove door
BS EN 10296-1	Steel tubes
BS ISO 10088:2001	
BS EN ISO 9094-2003	
BS EN 10297-1	Steel tubes
BS EN 13384-1	Chimneys
BS EN 10088-1:2005	Stainless steels - Part 1: List of stainless steels

INSTALLATION & GENERAL INSTRUCTIONS



Silent Simplicity just for you!

MARINE OIL STOVES ©

ISSUE 15 @ 22-06-18

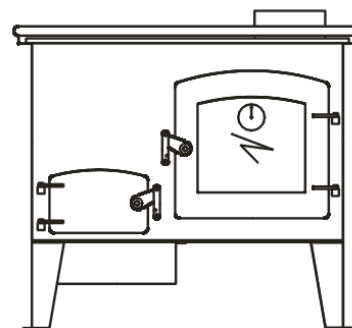
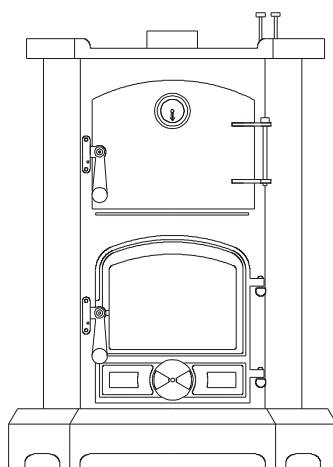
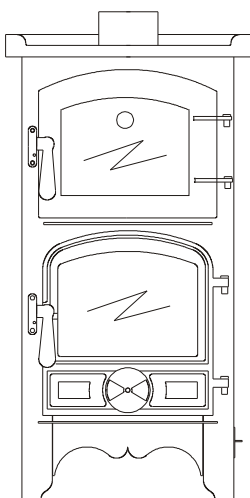
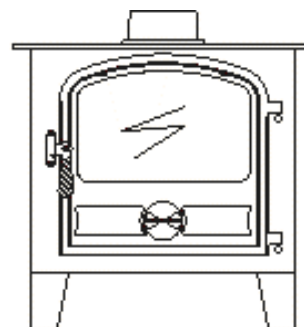
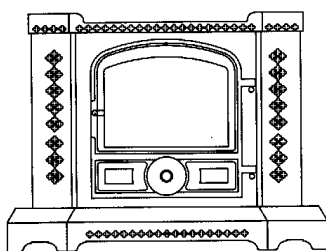
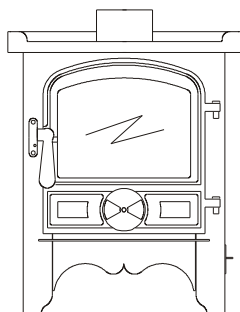

www.harworthheating.co.uk

INDEX

1. BEFORE STARTING THE JOB.	3
FITTING OPTIONS.	3
ABOUT THE APPLIANCES	3
2. SAFETY.	4
FUMES	4
FIRE	4
BURNS	4
CLEARANCES FROM COMBUSTIBLES	4
CLEARANCES FROM COMBUSTIBLES-FLUE PIPES	5
VENTILATION.	5
FLOODED VAPOURIZING BURNER POTS.	5
SECURELY FIX THE APPLIANCE	5
3. CHIMNEY	5
THE HEIGHT.	5
THE DIAMETER.	5
THE TEMPERATURE OF THE GASSES IN IT.	5
THE RESISTANCE OF THE INNER SURFACE OF THE FLUE PIPE OR PIPES.	5
THE TYPE OF TERMINAL.	5
THE PREVAILING ATMOSPHERIC CONDITIONS.	5
THE CHIMNEY RULES.	6
4. FUEL SUPPLY.	6
WAXING	6
AIR LOCKS	6
TRIM	6
TANK	6
OIL LINE	6
WATER CONTAMINATION	6
REMOTE SENSING FIREVALVES	7
ISOLATION VALVES.	7
SLEEVING.	7
OVERBOIL OR OVERHEAT PROTECTION OF THE APPLIANCE.	7
4A LIGHTING & COMMISSIONING	7
1. LIGHTING B1 HALF POD, B1 PIE POD AND B2	7
COMMISSIONING THE HIGH & LOW FIRE, CHRYSTAL SERIES	8
4B LIGHTING & COMMISSIONING THE BURNER SOCOMEF SERIES	9
1. LIGHTING CORNER STOVE, CORNER POD AND BACK CABIN COOKER.	9
COMMISSIONING THE HIGH AND LOW FIRE SOCOMEF BURNERS.	10
5. FIREPLACE.	10
6. DISTANCES FROM COMBUSTIBLES (APPLIANCES)	11
7. DISTANCES FROM NON COMBUSTIBLES (APPLIANCES)	11
8. DISTANCES FROM COMBUSTIBLES (FLUE PIPES)	11
9. ILLUSTRATIONS	12
FIG 1. STOVE DISTANCE FROM COMBUSTIBLES	12
FIG 2 BUBBLE MK1 FABRICATED DECK FLANGE LAYOUT	12
FIG 3 TYPICAL OIL FEED LAYOUT	13
FIG 4 TYPICAL PUMBING LAYOUTS	13
10. STOVE DIMENSIONS	14
10-1 BB1 HALF POD AND PIE POD DIMENSIONS	14
10-2 CORNER STOVE AND CORNER PIE POD DIMENSIONS	15
10-3 B2 STOVE DIMENSIONS	15
10-4 BACK CABIN COOKER DIMENSIONS	16
12. NORMATIVE REFERENCES	18

If you have any difficulties please phone our technical help line on-:

01302 742520 fax 01302 750573

e-mail contact@bubbleproducts.co.uk

<http://www.bubbleproducts.co.uk>

1. BEFORE STARTING THE JOB.

THE FOLLOWING NOTES PROVIDE INFORMATION FOR INSTALLATION OF THE FOLLOWING APPLIANCES.

Boat Bubble No 1 AND HALF POD, Dry Small and Large Boiler Appliances

Boat Bubble No 2 Dry Small and Large Boiler Appliances

Marine Corner Bubble Wet and Dry appliances

Bubble No 1 Cooking Stove plus boiler options.

Corner Cooking Stove plus boiler options.

Back Cabin Oil Fired Cooker.

FITTING OPTIONS.

There are normally two different situations that the installer may be faced with:-

1. A new build installation.

An established boat installation, (which has not had oil stove fitted).

2. A replacement installation, where there has been a solid fuel stove fitted previously.

Each of the situations will present differing problems which will be:-

- Where to locate the stove.
- How to deal with fireplace design.
- Where to locate the oil tank.
- How to get an oil supply to the stove.
- How to fit the chimney.
- How to connect water to the stove.
- How to disconnect and remove the stove, easily.

The new build situation should be the easiest.

The established boat situation will require careful attention to the sighting of the stove in relation to flue positions and existing fittings positions.

In replacement situations it may well be necessary to blank off the existing through roof flue position and cut a fresh one to suit the new location and comply with our instructions on flue design.

ABOUT THE APPLIANCES

Generally described as a space heater or space heater and cooker, which burns diesel oil in a controlled

manner utilizing a chimney to discharge the products of combustion.

The appliance generates heat from burning oil mixed with air in a vaporizing pot located in the bottom of the stove.

Once the appliance has been ignited, oil goes into the pot at a steady and controlled rate via a gravity feed which is metered by the OIL CONTROL VALVE; the oil flow can be controlled from minimum to maximum or any setting in between determined by the set position of the oil flow control knob.

Air is sucked into the pot by the natural action of the negative pressure in the chimney.

To allow the chimney to work correctly it is essential that you have adequate, unrestricted ventilation into the area where the stove is situated.

The amount of oil that can be successfully burned is directly proportional to the amount of air that the chimney can draw into the pot and so to achieve adequate combustion a balanced and appropriate flow of both oil and air is required.

The stove will provide space or combined space and water heating and in some cases cooking as well.

Where cooking and water heating are combined one feature will inevitably effect the other.

There are different versions of each appliance within the total range.

Some of the appliances are supplied as Dry, Small Boiler and Large Boiler versions namely B1 Half Pod, B1 Oven and B2.

Some of the appliances are supplied just as Dry and Large Boiler versions namely Corner Stove and Corner Oven Stove.

The Back Cabin Cooker can be supplied with or without a small boiler for domestic hot water heating only.(1kw)

All of the boilers are high water content and suitable for pumped or gravity systems and pressurised or open vented systems ASSUMING THAT THEY ARE INSTALLED BY SUITABLY QUALIFIED PERSONS.

All the appliances are fitted with a descaling device which should be rotated on a two weekly cycle to descale the oil inlet pipe.

Where applicable, appliances must not be operated with the glass front door opened or cracked, or without the lighting port plug fitted.

Where applicable, the door glass may require light cleaning occasionally depending upon the continuous running time of the stove.

Appliances must be securely bolted down to resist impact or collision and must be level in both directions.

All the appliances are supplied with clamp down brackets except the Back Cabin Cooker which must be fastened down through the foot plates.

The top of the appliances can be used for warming and cooking.

The oven appliances have a comprehensive range of cooking facilities with both oven and hot plate cooking available.

Some appliances can also be supplied with a coal kit, which just like a solid fuel stove, coal effect will only be available when the stove is running at maximum or near maximum performance.

Suitable deck flanges, flue systems and anti-downdraft cowls must be used.

CONTROLS

The output of the stove is regulated by the amount of oil allowed to go into it and this function is controlled by the -:

OIL CONTROL VALVE (O.C.V.), Turning the knob anti clockwise controls the oil flow.

2. SAFETY.

Take care to make sure that all safety and ventilation issues are adequately addressed.

FUMES

Always fit a suitable Smoke and Carbon Monoxide alarm within 1.5meters of the appliance.

Make sure that the function is checked on regular basis. (weekly)

Make sure that the alarm can be heard in the sleeping quarters.

Here are the main causes of fume or smoke to leak from the stove.

- The chimney is blocked.
- There are too many bends in the chimney.
- The above deck chimney extension is not high enough.
- The boat is moored in a position near to high buildings or trees and downdraughting is occurring.
- The chimney or parts of it are not airtight.

- There are unusually strong cross winds.

If down draughting occurs turn the appliance off until the winds subside and do not attempt to re-ignite the appliance until it has completely cooled down.

When it has cooled down, before attempting to ignite the appliance remove the catalyser and examine the base of the pot to make sure that there is no oil left in the pot, if there are signs of oil in the pot do not attempt to ignite the appliance until it has been completely dried out.

FIRE

Fire can be caused by a variety of potential danger points and because of the space limitation on boats; this risk is ever present and must be adequately assessed.

The main danger is the effects of heat from the stove on combustible materials and boat occupants.

Make sure that all combustibles are adequately protected from the effects of heat radiation.

Appliances must stand on a fireproof base of minimum thickness 30mm or a purpose made stand.

Floors in front of the stove must have suitable fire protection.

Built in stove heat shields should not be removed under any circumstances.

BURNS

During normal, day-to-day use, many parts of the stove, pipe work, and chimney will become too hot to touch.

Hot surfaces must be adequately protected to prevent anyone falling on to, or touching them.

Suitable fireguards for the appliance and chimney must be fitted.

Fireguards must comply with BS6539.

Always use heatproof gloves when working on or near to a hot stove.

CLEARANCES FROM COMBUSTIBLES

The appliances must be fitted in line with the distances specified in the tables.

All hearths and fireplaces must be made from non-combustible materials and adequately designed for the job.

CLEARANCES FROM COMBUSTIBLES-FLUE PIPES

Flue pipes must be fitted in line with the distances specified in the table and must be suitable for the individual application.

Any combustible materials within the specified distances from the appliances must be protected by a suitable heat shield.

Protection can be gained by the use of -:

- Sheet metal heat shields and spacers.
- Heat resistant boards such as TAC board.
Combustible materials can be-:
- Wooden furniture.
- Curtains.
- Wooden panels or frames adjacent to the flue pipe or where it passes through the deck of the boat.
- Carpet or flooring close to the stove.
- Items near to the stove, which could fall onto it and ignite, should the boat suffer a slight impact or collision.

VENTILATION.

Ventilation plays a vital role in the fitting and sighting of any stove.

The provision of ventilation for these appliances is adequately covered by the requirements of the boat safety scheme.

25cm sq. minimum permanent ventilation, directly to outside air, must be provided.

FLOODED VAPOURIZING BURNER POTS.

When attempting to light any of the appliances, make sure that the pot is not flooded with oil by looking into the base of the burner.

If it is flooded remove the excess oil.

Never try to relight a hot stove; wait until it has cooled down.

Hot oil vapour is explosive.

Never try to light a flooded pot.

SECURELY FIX THE APPLIANCE

The stove must be securely fastened down so that it can resist impact or collision and it must be level in both directions.

Level the stove in both directions when the vessel is midway between its maximum and minimum trim conditions.

Bubble appliances must not be fitted if the maximum angle of trim exceeds 0.75 deg forward to aft or port to starboard.

Only suitably qualified persons can install unvented plumbing systems.

A suitable and serviceable fire extinguisher should always be readily accessible.

3. CHIMNEY

This is the one of the most interesting problems the installer has to deal with and as the chimney affects most aspects of running the stove, we take time here to list the following information for your consideration.

The power, (*suck or vacuum the chimney can develop*) depends upon the following-:

THE HEIGHT.

THE DIAMETER.

THE TEMPERATURE OF THE GASSES IN IT.

THE RESISTANCE OF THE INNER SURFACE OF THE FLUE PIPE OR PIPES.

THE TYPE OF TERMINAL.

THE PREVAILING ATMOSPHERIC CONDITIONS.

It is obvious that on a boat all the above elements are in short supply.

Normally, we have low flues which are small in diameter and generally not very well insulated, coupled with all these problems we have another one, which is that the boat moves across constantly changing surroundings, through locks, into headwinds and crosswinds, all creating major opportunity for down draughting to occur.

Any bend in any part of the chimney or roughness on the internal chimney wall will slow down the velocity of rising gases and reduce the effectiveness of the chimney.

Any slight reduction in the flue gas temperature will reduce the chimney vacuum or pull, hence when the stove is slowed down for all night burning, as the flue gas cools down the chimney vacuum reduces and as the chimney vacuum drops, the stove may well start to burn sooty. This problem is highlighted even more during very cold weather when the chimney can cool down even faster. In these situations careful attention to servicing and low fire setting is essential.

THE CHIMNEY RULES.

1. Always use a top outlet for flue pipe take off.
2. Always try to get the stove as low as possible in the boat, this will allow installation of maximum length flue pipe.
3. Clean or have the chimney cleaned regularly. (Frequency depends upon type of fuel and length of time used).

4. FUEL SUPPLY.

There are several problems relating to diesel fuel supply, which need be adequately addressed.

WAXING

Cold weather waxing or thickening alters the flow characteristics of diesel.

An adequate fuel feed supply can turn into an inadequate one when the temperature starts to fall.

The worst scenario is fuel feed pipe 50-60 feet long in 8mm dia pipe.

The best-case scenario is a fuel pipe 4 feet long in 10mm dia with insulated lagging.

AIR LOCKS

Air lock in oil feed pipe work must be avoided.

The pipe work must slope down to the appliance and be clipped level at 500mm intervals to prevent sagging.

Any rises in the pipe work will cause air locks on commissioning and after future oil run out situations, if it is not possible to run the pipe work in a steady slope then where changes occur a vertical venting leg should be fitted.

TRIM

Bubble appliances must not be fitted if the maximum angle of trim exceeds 0.75 deg forward to aft or port to starboard.

Level the stove in both directions when the vessel is midway between its maximum and minimum trim conditions.

A minimum pressure head of 254mm (10") is required.

This head is measured from the base of the oil tank to the top of the oil control valve. In some cases this head can be affected by the ballast or trim of the boat.

Take great care to try out all the different ballast and trim possibilities to make sure that adequate oil feed is always available at the outlet end of the fuel pipe before it enters the oil control valve at the stove.

TANK

If the stove is fitted at the bow of the boat, a bow tank is recommended.

The tank should comply with the requirements of the boat safety scheme and have:-

- A conveniently sized filler
- A means of venting.
- A conveniently located, easily visible, contents gauge.
- An isolation valve
- An easily replaceable cartridge filter.
- A suitable and substantial water trap

Do not use glass filter bowls, they are not acceptable under the boat safety scheme.

Make sure that your fuel supplier supplies you with appropriate fuel for wintertime running.

OIL LINE

The oil feed line starts after the fuel filter and proceeds to the point of entry, which is where the oil line goes into the cab or saloon of the boat.

The diameter of the oil line is dependent upon the length of run. See 3-2 on waxing and make sure that you have suitably sized compression fittings available.

At this point it is necessary to fit a 60 DEG C, remote sensing fire valve, designed to shut off the oil supply, should a fire occur near to the stove.

If the bubble stove is fitted up to the first bulkhead it will be necessary to fit the isolation valve outside the cabin or saloon of the boat. 5. Make sure that you have purged the oil feed line of all air and there is a steady and constant flow of oil available at the inlet to the oil valve. Make sure that all or any oil isolation devices are turned to the on position. Remember that the oil valve needs a min head of 300mm for gravity feed. When feeding from rear tanks with appliances fitted forward always be aware of the forward - aft trim of the vessel.

Do not use syphonic oil feeds to Bubble Appliances, oil should be fed by gravity or pumped via an appropriate pressure pump = head pressure less than 99mbar.

WATER CONTAMINATION

Because of the high risk of fuel contamination with water, we strongly recommend the fitting of a **high volume water trap**, in the oil supply line.

REMOTE SENSING FIREVALVES

There are two situations where a remote sensing firevalve should be fitted.

1. For fire protection fit a 60 deg C valve.
2. For over boil protection fit an additional 90 deg C valve.

For fire protection a remote sensing fire valve should be fitted as detailed in fig 3.

Run the capillary tube with the oil line up to the stove and carefully fit the sensing phial as follows

B1 Half Pod, B1 Oven and B2 at a low level fitted on two 15mm pipe clips.

Corner Stove and Corner Oven Stove on 15mm pipe clips in front of the drip tray on the fireplace hearth, directly in front of the combustion air restrictor.

Before it is fitted try the fender on the stove to make sure that the fender does not foul the sensing phial.

The sensing phial may be visible through the bottom of the fender, to mask it, paint it with matt black paint available from our sales desk.

When fitting the fire valve make sure that where the capillary and oil line go through the bulkhead in separate sleeved tubes, so that the capillary can be withdrawn separately should it ever need replacing.

For fitting of long oil feed lines which pass through bulkheads and various other parts of the boat it may well be necessary to fit more than one fire valve, especially where the oil line passes through an area where a fire could occur i.e. kitchen area etc.

ISOLATION VALVES.

Two isolation valves are required, one fitted directly into or close to the oil control valve to allow you or the service man to turn the oil off should the need arise, and one fitted directly into the oil tank before the fuel filter.

Always turn off the oil isolation valve serving the appliance before leaving the vessel unattended.

SLEEVING.

Where the oil line goes through the boat superstructure a suitable bulkhead fitting must be used.

OVERBOIL OR OVERHEAT PROTECTION OF THE APPLIANCE.

Where appliances are not fitted with an automatic thermostat an additional 90 DEG C, remote sensing

fire valve must be fitted directly in front of the oil control valve and the sensor from this valve has to be attached to the water jacket or the hot outlet pipe from the boiler.

The valve is calibrated to shut the oil supply down should the water temperature exceed 90 Deg C.

There is a re set button on the remote sensing fire valve which needs to be pressed in to re set the valve after it has tripped off.

4A LIGHTING & COMMISSIONING

A relevant oil control valve catalogue is supplied with each appliance and details of high and low fire adjusting screws are illustrated.

On the Toby valve the low fire screw is clearly visible as per TOBY MANUAL FIG 2

Before trying to light the burner in cold weather it is advisable to pre heat the flue pipe before lighting.

There are two different types of burner fitted to Bubble appliances.

The FB style burner fitted to the **B1 Half Pod, B1 Pie Pod and B2.**

The Socomef burner fitted to the **Corner Stove, Corner Oven Stove** and the **Back Cabin Cooker see sec 4B for lighting Socomef burners.**

1. LIGHTING B1 HALF POD, B1 PIE POD AND B2

When attempting to light the stove these are the rules, which must be followed.

1. Always make sure that the pot is **not** flooded with oil by looking down into the base of the pot.
2. Never try to light the stove if it is flooded with oil.
3. Always check that oil has not leaked from the appliance.
4. Do not light the stove and leave it unattended until it is settled down and stabilized into constant blue flame combustion on low fire. (This could take 10 to 20 minutes.)

On first light up it is advisable to warm the flue pipe up to try and create chimney draft.

Two Ways to Light the Stove

1. Through the lighting port B1 and B2 appliances only,
or
2. Directly into the base of the pot by removing the catalyser.

Lighting into the base of the Pot

On the first light up you may find this option better, as it is possible to see the oil trickle in to the pot more easily.

Use a heatproof glove when putting the catalysers back into the pot and it is important to replace them quickly whilst the flame is small.

Make sure that the oil is turned off.

Open the front door.

Remove the optional coal kit if fitted.

Remove the catalyser.

Turn the oil on and allow a small pool of oil to flow into the pot about the size of a small biscuit, **then turn the oil off.**

Note that on first light up it may take a few minutes for the oil to reach the pot as it has to fill the pipework before reaching the pot, take care not to allow excess oil to flow into the pot.

Light a small piece of firelighter and drop it into the oil, allow a few seconds for it to get going and then replace the catalyser and coal kit if fitted, and close the door.

Wait for approx. 1 minute until the pool of oil is alight and then **turn the oil on** to minimum setting no 1.

Watch the appliance for a few minutes and you will see the flame establish and settle down into blue flame combustion.

Allow the burner to run for a further 10 minutes before turning the appliance up to the higher settings.

If at any time during the ignition process large amounts of flame can be seen, turn the oil off immediately and wait until the flames die down before putting the oil on again at minimum setting.

Manual Lighting through the Lighting Port B1 and B2 appliances.

Check that the isolation valve is turned on.

Open the front door.

Remove the front apron on B1 Half Pod and B1 pie Pod.

Remove the lighting port plug by pulling it out of its tubular socket.

Turn the oil on to the first position via the flow control knob and allow a small pool of oil to flow into the pot about the size of a small biscuit.

Turn the oil off.

Cut a small piece of firelighter and stab it onto the spike.

Light it and push it into the lighting port tube, let the firelighter drop off the spike into the bottom of the pot.

Replace the lighting port plug back into the tube.

Close the front door.

Turn the fuel flow on again at the lowest setting

Watch the appliance for a few minutes until it settles down into blue flame combustion.

Allow the burner to run for a further 10 minutes before turning the appliance up to the higher settings.

If at any time during the ignition process large amounts of flame can be seen, turn the oil off immediately and wait until they die down before putting the oil on again.

Note there may be the occasional growl or audible vibration whilst the burner settles down into blue flame combustion.

COMMISSIONING THE HIGH & LOW FIRE, CHRYSTAL SERIES

Used in B1 Half Pod, B1 Pie Pod and B2

When the burner has established good blue flame combustion turn it up to half output. (Setting 3 on the fuel flow control knob) and let it stabilize.

Allow at least half an hour for the chimney to warm up thoroughly before making any adjustments to the high or low fire screws.

Turn the stove down onto minimum firing rate and let it stabilize.

After stabilization there should be a dull red glow in the lower catalyser with wispy blue flames flicking into and just over it.

If the flame falls into a dirty rolling yellow flame and the catalyser is not dull red then the low fire will need to be increased until it can support the required blue flame combustion.

To increase the low fire oil flow, screw the adjusting screw out by quarter turn increments.

When you are happy with the low fire, set the high fire.

Turn the oil flow knob up to setting 4, let the flame stabilize, and look at it, if it is stable and blue, turn it up slowly using the control knob, letting it stabilize after each movement, if the flame starts to go yellow with long flame combustion, it is running fuel rich and

the high fire screw needs adjusting to reduce the flow of oil. (Screw the adjuster screw in to reduce the high fire oil flow.)

Before adjusting the high fire screw, turn the flame down and let it stabilize in blue flame combustion, adjust the high fire screw by half a turn in and try turning the fuel flow up, if it is still fuel rich repeat the process until the high fire flame is running blue with just flicks of yellow in the tips.

To see a bubble stove running correctly see the following link

<https://www.youtube.com/watch?v=UqdQLFp3HkQ>

4B LIGHTING & COMMISSIONING THE BURNER SOCOMEF SERIES

1. LIGHTING CORNER STOVE, CORNER POD AND BACK CABIN COOKER.

When attempting to light the stove these are the rules, which must be followed.

1. Always make sure that the pot is not flooded with oil by looking down into the base of the pot.
2. Never try to light the stove if it is flooded with oil.
3. Always check that oil has not leaked from the appliance.
4. Do not light the stove and leave it unattended until it is settled down and stabilized into constant blue flame combustion on low fire. (This could take 10 to 20 minutes.)
5. Make sure that you have purged the oil feed line of all air and there is a steady and constant flow of oil available at the inlet to the oil valve. Make sure that all or any oil isolation devices are turned to the on position. Remember that the oil valve needs a min head of 300mm for gravity feed. When feeding from rear tanks with appliances fitted forward always be aware of the forward - aft trim of the vessel.
6. Do not use syphonic oil feeds to Bubble Appliances, oil should be fed by gravity or pumped via an appropriate pressure pump = head pressure less than 99mbar.

On first light up it is advisable to warm the flue pipe up to try and create chimney draft.

Lighting the Stove

Lighting the stove takes a little time and patience; the following procedure should be adopted.

In the case of the Corner appliances, open the front door and in the case of the Back Cabin Cooker remove the hot plate and top baffle to gain access to the

burner, note that the back cabin cooker has a lighting port fitted behind the lower ash pit door.

Remove the coal kit if it has been supplied with the stove.

Lift the inner mesh catalyser from the burner.



Look into the bottom of the pot and turn the oil on at full rate, allow oil to flow into the bottom of the pot to form a pool about the size of a small digestive biscuit and then turn the oil off.

Note that on first light up it may take a few minutes for the oil to reach the pot as it has to fill the pipework before reaching the pot.

Do not allow any depth of oil to build up.

Light a small piece of firelighter (about the size of a pineapple chunk) and place it into the centre of the oil pool.

Replace the mesh catalyser and the coal kit, if fitted and then leave the door slightly open whilst the firelighter gets the oil going.

After 30 to 40 seconds, you will notice the flame start to establish itself and spread around the bottom of the pot.

When this occurs, close the door or replace the baffle and top plate and then turn the oil on to its minimum setting.

After two or three minutes the flame should slowly change from yellow into blue flame combustion and settle down to a steady burn.

Note there may be the occasional growl or audible vibration whilst the burner settles down into blue flame combustion.

Allow the burner 10 - 15 minutes to stabilise and then increase the flow of oil as required, moving by one increment of the dial only.

Do not leave the appliance unattended during the lighting and stabilising procedure.

COMMISSIONING THE HIGH AND LOW FIRE SOCOMEF BURNERS.

Corner Stove, Corner Pod and Back Cabin Cooker.

Note that Back cabin Cookers are pre commissioned at the factory and do not need adjusting.

A relevant oil control valve catalogue is supplied with each appliance and details of high and low fire adjusting screws are illustrated.

On the Toby valve the low fire screw is clearly visible as per TOBY MANUAL FIG 2

When the burner has established good blue flame combustion turn it up to half output. (Setting 3 on the fuel flow control knob) and let it stabilize for a minute. Allow at least half an hour for the chimney to warm up thoroughly before making any adjustments to the high or low fire screws.

Turn the stove down onto minimum firing rate and again let it stabilize.

After stabilization there should be a dull red glow in the catalyser with wispy blue flames flickering just over the top of it, approximately level with the top of the pot.

If the flame falls into a dirty rolling yellow flame and the catalyser is not dull red then the low fire will need to be increased until the burner can support the required blue flame combustion.

When you are happy with the low fire, set the high fire.

Turn the oil flow knob up to setting 4, let the flame stabilize, and look at it, if it is stable and blue, turn it up slowly using the control knob, letting it stabilize after each movement, if the flame starts to go yellow with long flame combustion, it is running fuel rich and the high fire screw needs adjusting to reduce the flow of oil. (Screw the adjuster screw in to reduce the high fire oil flow.)

Before adjusting the high fire screw, turn the flame down and let it stabilize in blue flame combustion, adjust the high fire screw by half a turn in and try turning the fuel flow up, if it is still fuel rich repeat the process until the high fire flame is running blue with flicks of yellow in the tips.

On the Socomef pot, the high fire flame will be set approx. 40mm above the top of the pot.

NOTE THAT THIS PROCEDURE WILL NOT BE POSSIBLE IF THE CHIMNEY RULES HAVE NOT BEEN ADHERED TO.

THE HIGH FIRE SETTING WILL HAVE TO BE ADJUSTED IN LINE WITH THE AVAILABLE GENERATED CHIMNEY VACUUM IE

THE FLUE PIPE MUST BE A MINIMUM OF 1.8 METERS HIGH FOR LOW FIRE AND 2.1 METERS FOR HIGH FIRE.

INSTALLING ENGINEERS SHOULD NOT LEAVE THE APPLIANCE UNDER THE CONTROL OF THE CUSTOMER UNLESS THE APPLIANCE HAS BEEN CORRECTLY COMMISSIONED.

TO SEE HOW THE BURNER SHOULD OPERATE COMMISSIONING AND INSTALLING ENGINEERS SHOULD VISIT

<https://www.youtube.com/watch?v=UqdQLFp3HkQ>

This video shows a stove running from low to high fire and back to low fire. Note that this video is filmed on a normal house chimney and so it may not be possible to get exactly the same conditions on a typical boat flue as the fuel air ratio will not be exactly the same, hence the need for fine tuning the oil flow to the chimney air flow capability.

5. FIREPLACE.

Unless one is built into the appliance, always fit appliances on a suitable drip tray.

The possibility of oil drops leaking from the stove must be considered; a suitable oil drip tray must be fitted and designed in such a way, as it will contain any oil leaks or drips.

Normally the tray will cover the footprint of the stove, the oil valve and isolation device.

It will be oil tight and have a vertical up stand of at least 30mm. This should give a minimum containment volume of 2 litres.

It will be securely fastened down to the vessel and the appliance must be securely fastened down to the oil drip tray.

Make sure that drip trays are tested to ensure that they do not leak when filled with oil.

The hearth must be:-

FLAT - SECURE - FIREPROOF AND LEVEL IN BOTH DIRECTIONS.

Use materials, which are easy to keep clean and fireproof such as tiles, asbestolux or vermiculite boarding with a suitable weight resistant liner.

The vertical walls of the fireplace must also be made from fireproof materials.

Use fireproof, rockwool infill behind the fireplace panels to protect any combustible insulation materials

such as spray foam.

6. DISTANCES FROM COMBUSTIBLES (APPLIANCES)

Stove Type	ABOVE	SIDES.	BACK	FRONT	HEARTH Non Combustible Material
B1 HALF POD and OVEN VERSION	500	300	150 FROM HEAT SHIELD	300 to allow door opening.	30MM THICK x 100 projection at the front and sides
BOAT B2	600	300	150 FROM HEAT SHIELD	300 to allow door opening.	30MM THICK x 100 projection at the front and sides
CORNER and OVEN VERSION	500	75	100 FROM HEAT SHIELD	300 to allow door opening.	30MM THICK x 100 projection at the front.
BACK CABIN COOKER	500	150	100 FROM HEAT SHIELD	300 to allow door opening.	25MM THICK x 150 projection at sides

7. DISTANCES FROM NON COMBUSTIBLES (APPLIANCES)

Stove Type	ABOVE	SIDES.	BACK	FRONT	HEARTH Non Combustible Material
B1 HALF POD and OVEN VERSION	300	150	150 FROM HEAT SHIELD	300 to allow door opening.	30MM THICK x 100 projection at the front and sides.
BOAT B2	300	150	150 FROM HEAT SHIELD	300 to allow door opening.	30MM THICK x 100 projection at the front and sides.
CORNER and OVEN VERSION	200	150	25 FROM HEAT SHIELD	300 to allow door opening.	30MM THICK x 100 projection at the front and sides.
BACK CABIN COOKER	500	75	50 FROM HEAT SHIELD	300 to allow door opening.	25MM THICK x 75 projection at sides

Note that the back cabin cooker can have the oil control valve fitted to the rear or the left hand side in each case the positioning of the valve will affect the fireplace and spacing considerations, see sizes of cooker to establish requirements.

8. DISTANCES FROM COMBUSTIBLES (FLUE PIPES)

For all appliances-:

1. Single skin flue pipes. Horizontal Distance = 50mm **when fitted within the deck flange** at the top of the chimney system, protected by the fire stop spacer.
2. Single skin flue pipes. Horizontal Distance = 150mm **when exposed in the saloon or living space.**
3. Twin Wall Insulated flue pipes. Horizontal Distance = 30 mm for insulated flue pipe systems.

9. ILLUSTRATIONS

FIG 1. STOVE DISTANCE FROM COMBUSTIBLES

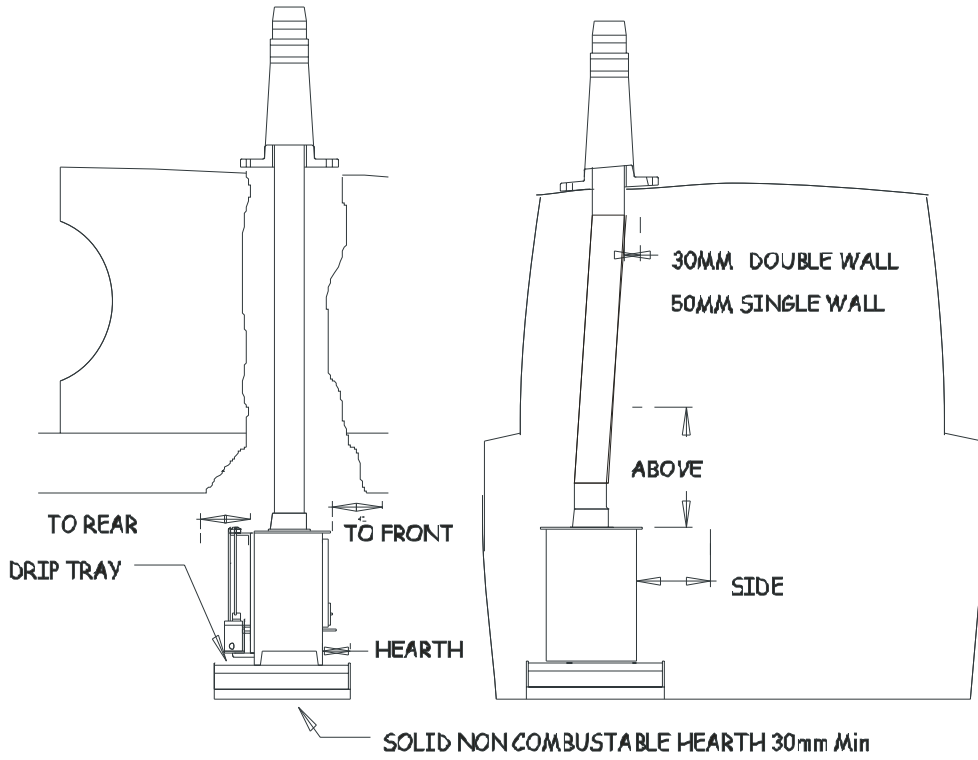

FIG 2 BUBBLE MK1 FABRICATED DECK FLANGE LAYOUT

Note that there is mk3 system which is now available and detailed on our web site.

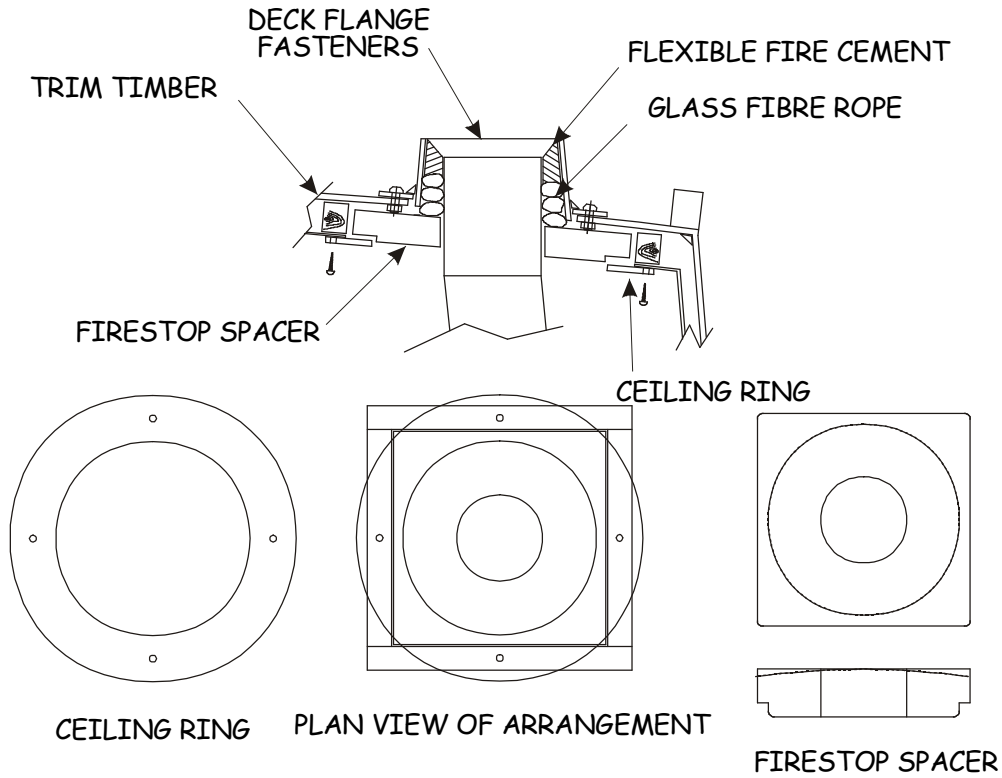
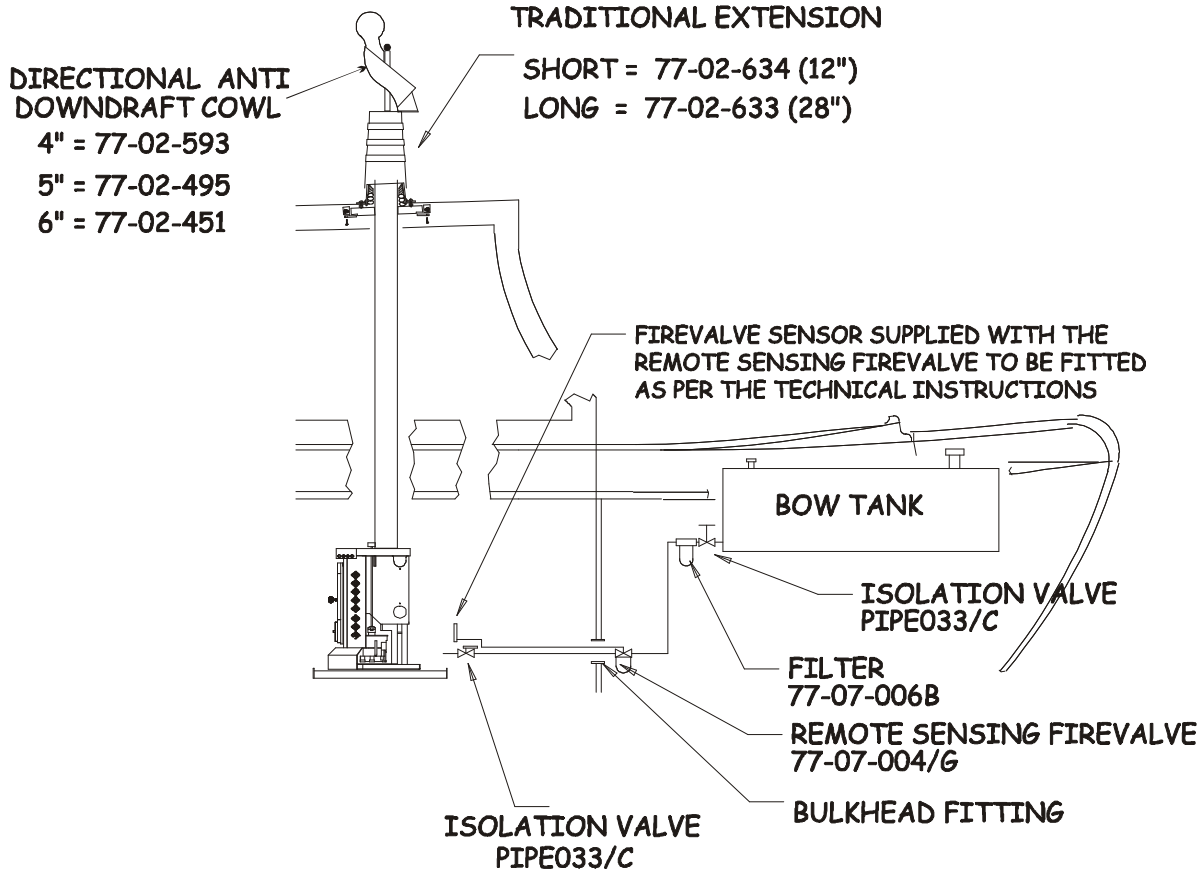

FIG 3 TYPICAL OIL FEED LAYOUT



COPYRIGHT HARWORTH HEATING LTD 080800

FIG 4 TYPICAL PUMING LAYOUTS

Drq 1

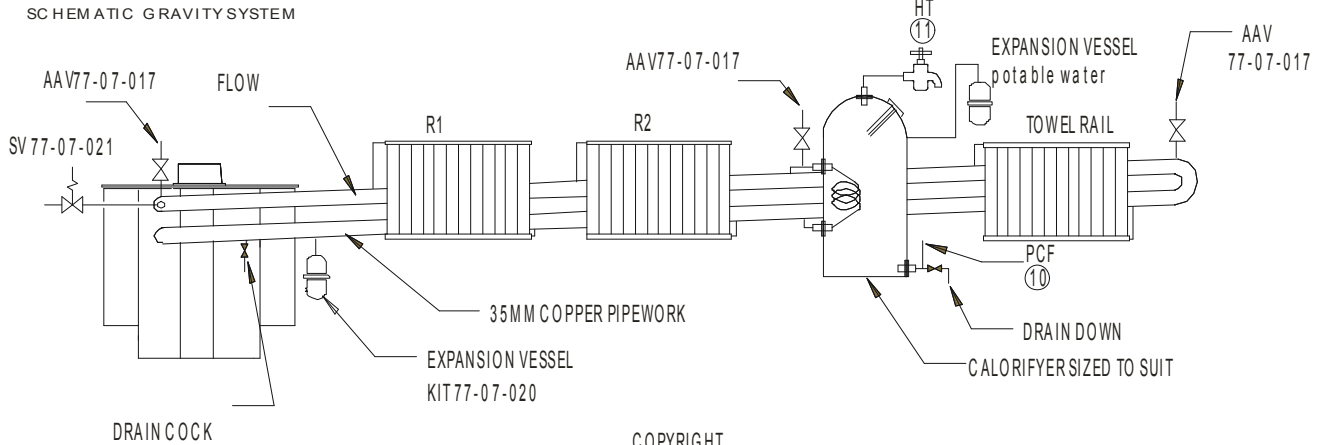

COPYRIGHT BUBBLE PRODUCTS 2013

Drg 2

SCHEMATIC PUMPED SYSTEM ISS 2 OF 28-10-17

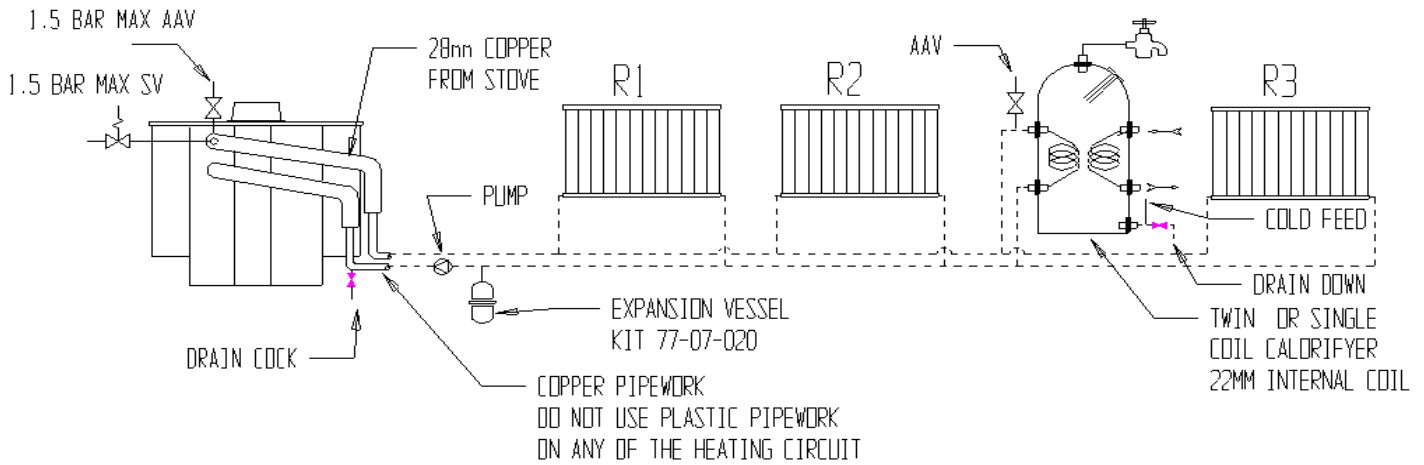

Drg 3

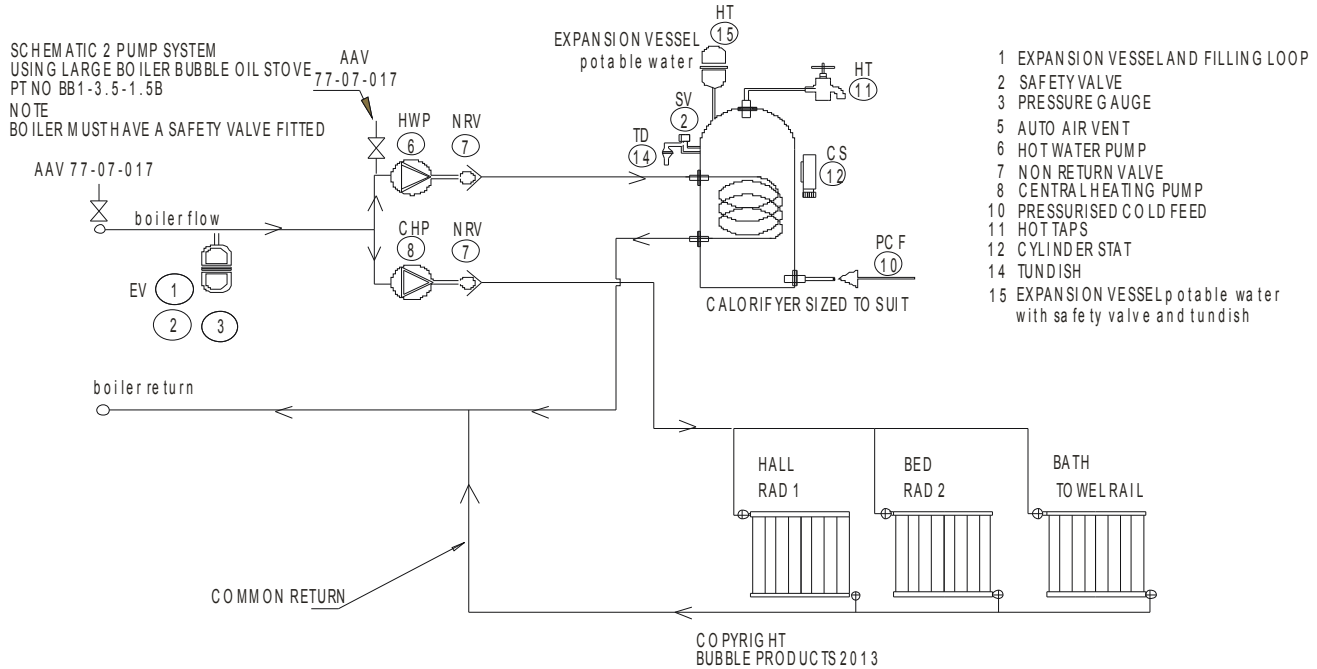

10. STOVE DIMENSIONS

10-1 BB1 HALF POD AND PIE POD DIMENSIONS

Note that the B1 Pie Pod has the same footprint dimensions but the vertical height is 830mm.

**B1 HALF OIL POD OF 12-02-15
OVERALL DIMENSIONS
BOILER AND NON BOILER VERSIONS**

**.WEIGHT 35.KG NON BOILER
.WEIGHT 45.KG SMALL BOILER
.WEIGHT 50.KG LARGE BOILER**

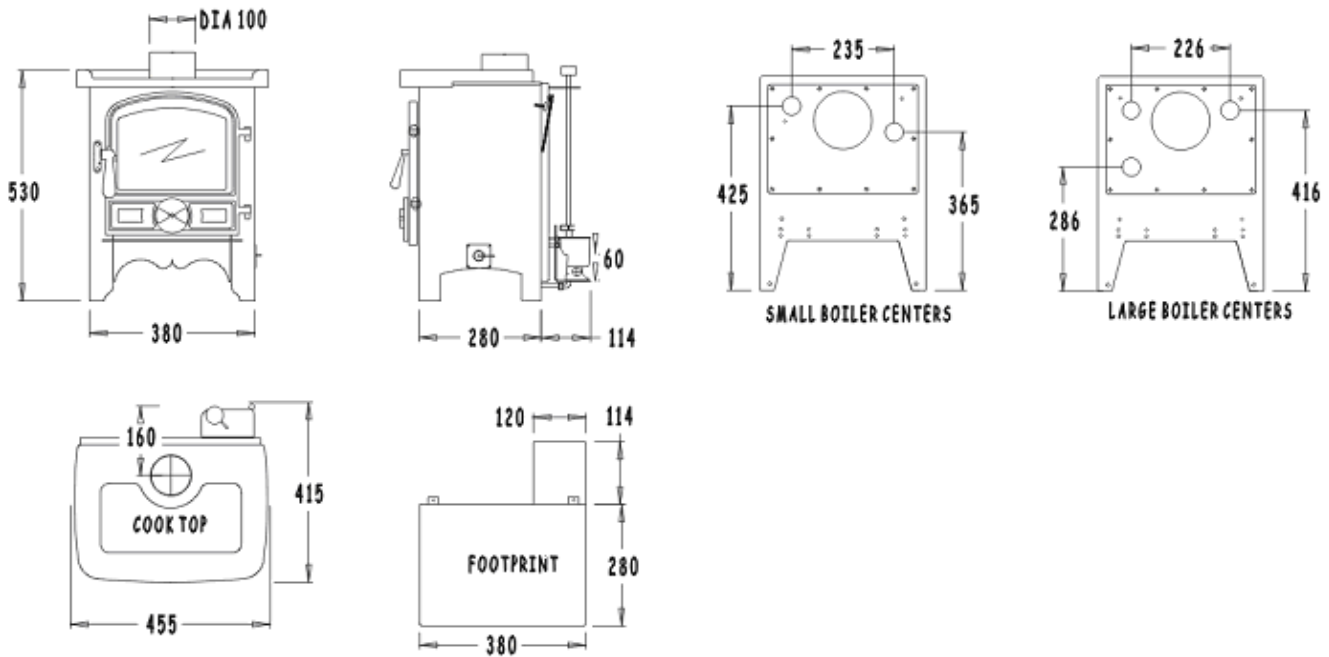

10-2 CORNER STOVE AND CORNER PIE POD DIMENSIONS

Note that the Corner Pie Pod has the same footprint dimensions but the vertical height is 840mm.

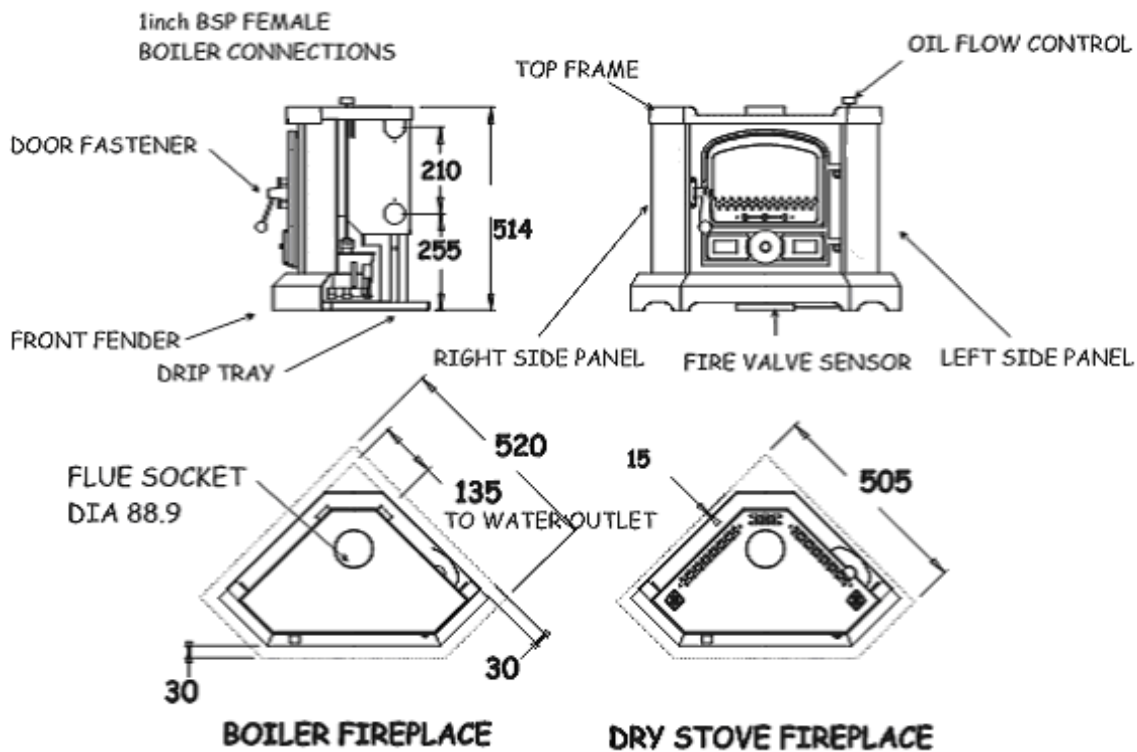

10-3 B2 STOVE DIMENSIONS

Note that the B2 Pie Pod has the same footprint dimensions but the vertical height is 830mm.

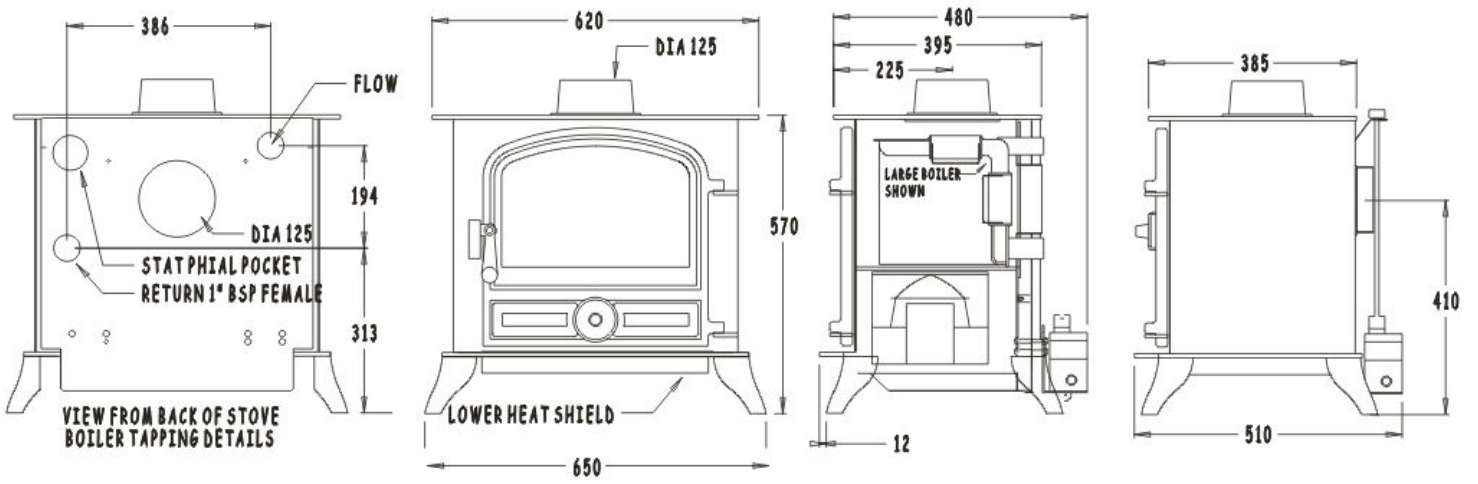

10-4 BACK CABIN COOKER DIMENSIONS

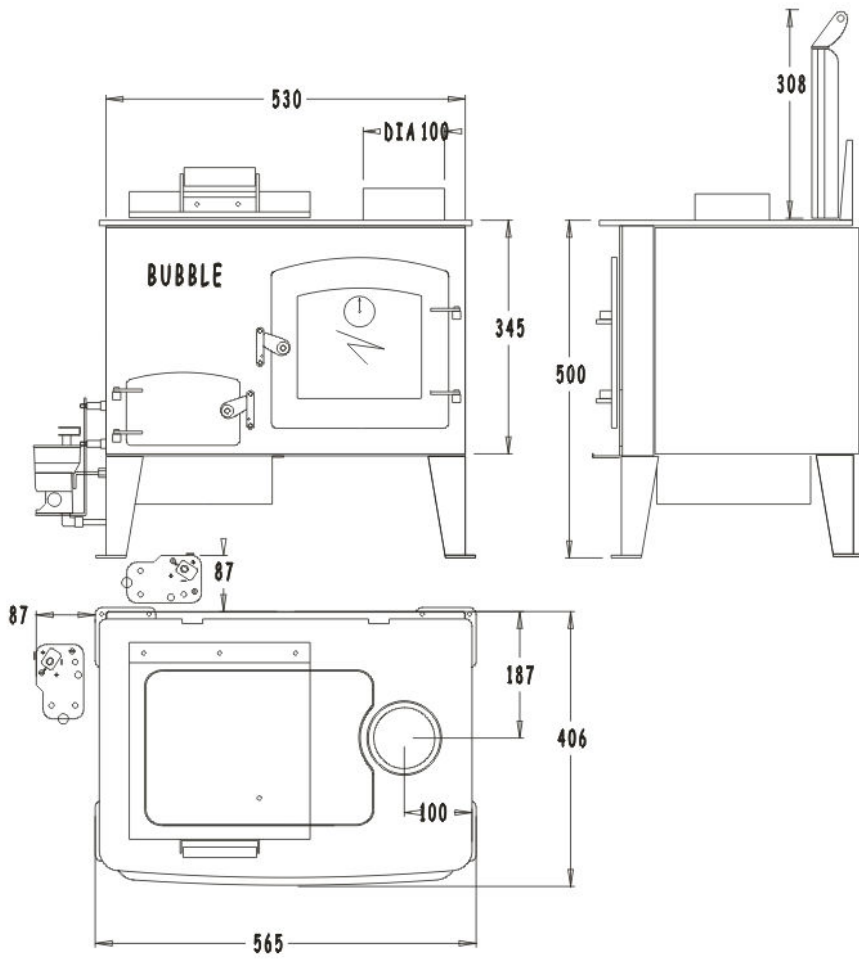

11. OIL CONSUMPTION RATES

		MAX HEAT OUTPUT TO WATER	MAX HEAT OUTPUT TO SPACE	MINIMUM OIL FLOW CC'S PER MIN	MAXIMUM OIL FLOW CC'S PER MINUTE
--	--	--------------------------	--------------------------	-------------------------------	----------------------------------

B1 HALF POD & OVEN DERIVATIVE

Free Standing	From 1.6kW to 5kW		5kW	4 = (1.6kW)	12 = (5kW)
Free Standing	From 1.6kW to 5kW	2kW	3kW	4 = (1.6kW)	12 = (5kW)
Free Standing	From 1.6kW to 6kW	5kW	2kW	4 = (1.6kW)	13 = (6kW)

CORNER STOVE & OVEN DERIVATIVE

Free Standing	From 1kW to 4kW		4kW	3 = (1kW)	10 = (4kW)
Free Standing	From 1kW to 4kW	3kW	1kW	3 = (1kW)	10 = (4kW)

BUBBLE 2

Free Standing	From 1.6kW to 5kW		5kW	4 = (1.6kW)	13 = (5kW)
Free Standing	From 1.6kW to 8kW		8kW	4 = (1.6kW)	16 = (8kW)
Free Standing	From 1.6kW to 8kW	3kW	5kW	4 = (1.6kW)	16 = (8kW)
Free Standing	From 1.6kW to 8kW	9kW	2kW	4 = (1.6kW)	22 = (11kW)

BACK CABIN COOKER

Free Standing	From 1.6kW to 5kW		3kW	4 = (1.6kW)	7 = (3kW)
Free Standing	From 1.6kW to 5kW	1kW	2kW	4 = (1.6kW)	7 = (3kW)

© HARWORTH HEATING LTD 30.6.98

This publication may not be copied by any means, without written permission from the authors.

These products are subject to continuous development and improvement and it is consequently acknowledged that due to this process there may be some omissions and errors.

This publication is intended only to assist the reader in the use of this product and therefore Harworth Heating Ltd shall not be liable for any loss or damage whatsoever arising from the use of any information, error or omission found in this publication.

The appliances mentioned in this publication can only be installed and serviced by approved personnel.

Approved personnel means that they must HAVE BEEN SUITABLY TRAINED, if there are any

reliability issues reported back to **Harworth Heating** or **Bubble Products**, the installing engineer will be responsible for carrying out any rectification work.

For details of suitable training courses contact: - www.oftec.org

12. NORMATIVE REFERENCES

Boat installation work comes under the control of: -
The Boat Safety Scheme.

This scheme provides statutory requirements and associated EN / BS Standards for most aspects of installation work on boats.

Further information and a copy of the requirements can be obtained from:-

www.boatsafetyscheme.com

Where guidance for oil fired appliances is not readily available from the Boat safety Scheme publication, we then point out a list of standards which pertain to domestic installations and which are generally covered by the latest version of the English Building Regulations Doc J.

When read in conjunction with:-

1. Our installation instructions.
2. The Boat Safety Scheme rules.
3. The other standards detailed, enough information should be provided to allow for a safe installation.

BS 5440	Flues.
BS 6999	Flues
BS 7840	Fuel Hoses.
BS EN1057	Copper Tubes.
BS1344 Part 3 1988 ISO8290 1987	Flues.
BS EN 1443:2003	Chimneys - General requirements.
BS EN1856 part 1 replacing BS 4543	Flues.
BS EN1856 part 2 & BS 715 1993	Flues.
BS 1945: 1971	Stove door
BS EN 10296-1	Steel tubes
BS ISO 10088:2001	
BS EN ISO 9094-2003	
BS EN 10297-1	Steel tubes
BS EN 13384-1	Chimneys
BS EN 10088-1:2005	Stainless steels - Part 1: List of stainless steels

INSTALLATION & GENERAL INSTRUCTIONS



Silent Simplicity just for you!

MARINE OIL STOVES ©

ISSUE 15 @ 22-06-18

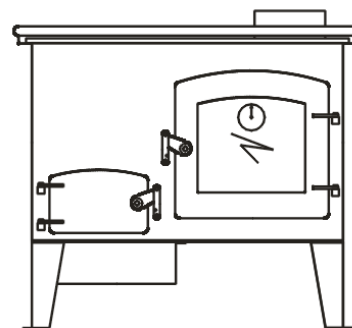
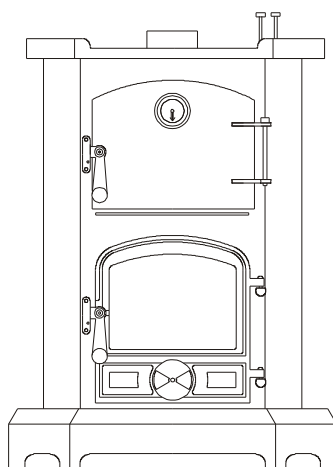
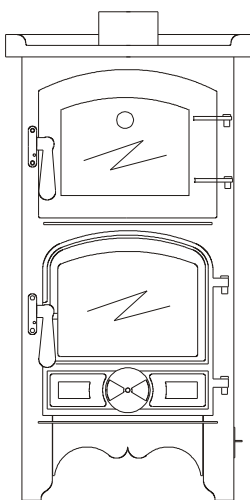
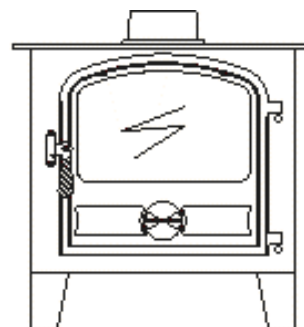
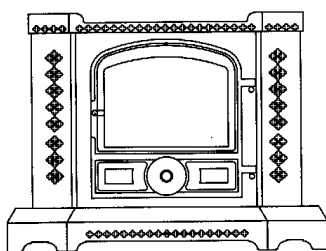
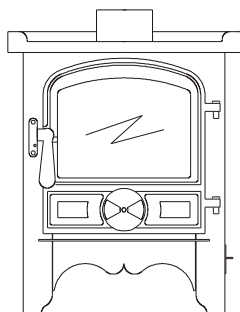

www.harworthheating.co.uk

INDEX

1. BEFORE STARTING THE JOB.	3
FITTING OPTIONS.	3
ABOUT THE APPLIANCES	3
2. SAFETY.	4
FUMES	4
FIRE	4
BURNS	4
CLEARANCES FROM COMBUSTIBLES	4
CLEARANCES FROM COMBUSTIBLES-FLUE PIPES	5
VENTILATION.	5
FLOODED VAPOURIZING BURNER POTS.	5
SECURELY FIX THE APPLIANCE	5
3. CHIMNEY	5
THE HEIGHT.	5
THE DIAMETER.	5
THE TEMPERATURE OF THE GASSES IN IT.	5
THE RESISTANCE OF THE INNER SURFACE OF THE FLUE PIPE OR PIPES.	5
THE TYPE OF TERMINAL.	5
THE PREVAILING ATMOSPHERIC CONDITIONS.	5
THE CHIMNEY RULES.	6
4. FUEL SUPPLY.	6
WAXING	6
AIR LOCKS	6
TRIM	6
TANK	6
OIL LINE	6
WATER CONTAMINATION	6
REMOTE SENSING FIREVALVES	7
ISOLATION VALVES.	7
SLEEVING.	7
OVERBOIL OR OVERHEAT PROTECTION OF THE APPLIANCE.	7
4A LIGHTING & COMMISSIONING	7
1. LIGHTING B1 HALF POD, B1 PIE POD AND B2	7
COMMISSIONING THE HIGH & LOW FIRE, CHRYSAL SERIES	8
4B LIGHTING & COMMISSIONING THE BURNER SOCOMEF SERIES	9
1. LIGHTING CORNER STOVE, CORNER POD AND BACK CABIN COOKER.	9
COMMISSIONING THE HIGH AND LOW FIRE SOCOMEF BURNERS.	10
5. FIREPLACE.	10
6. DISTANCES FROM COMBUSTIBLES (APPLIANCES)	11
7. DISTANCES FROM NON COMBUSTIBLES (APPLIANCES)	11
8. DISTANCES FROM COMBUSTIBLES (FLUE PIPES)	11
9. ILLUSTRATIONS	12
FIG 1. STOVE DISTANCE FROM COMBUSTIBLES	12
FIG 2 BUBBLE MK1 FABRICATED DECK FLANGE LAYOUT	12
FIG 3 TYPICAL OIL FEED LAYOUT	13
FIG 4 TYPICAL PUMBING LAYOUTS	13
10. STOVE DIMENSIONS	14
10-1 BB1 HALF POD AND PIE POD DIMENSIONS	14
10-2 CORNER STOVE AND CORNER PIE POD DIMENSIONS	15
10-3 B2 STOVE DIMENSIONS	15
10-4 BACK CABIN COOKER DIMENSIONS	16
12. NORMATIVE REFERENCES	18

If you have any difficulties please phone our technical help line on-:

01302 742520 fax 01302 750573

e-mail contact@bubbleproducts.co.uk

<http://www.bubbleproducts.co.uk>

1. BEFORE STARTING THE JOB.

THE FOLLOWING NOTES PROVIDE INFORMATION FOR INSTALLATION OF THE FOLLOWING APPLIANCES.

Boat Bubble No 1 AND HALF POD, Dry Small and Large Boiler Appliances

Boat Bubble No 2 Dry Small and Large Boiler Appliances

Marine Corner Bubble Wet and Dry appliances

Bubble No 1 Cooking Stove plus boiler options.

Corner Cooking Stove plus boiler options.

Back Cabin Oil Fired Cooker.

FITTING OPTIONS.

There are normally two different situations that the installer may be faced with:-

1. A new build installation.

An established boat installation, (which has not had oil stove fitted).

2. A replacement installation, where there has been a solid fuel stove fitted previously.

Each of the situations will present differing problems which will be:-

- Where to locate the stove.
- How to deal with fireplace design.
- Where to locate the oil tank.
- How to get an oil supply to the stove.
- How to fit the chimney.
- How to connect water to the stove.
- How to disconnect and remove the stove, easily.

The new build situation should be the easiest.

The established boat situation will require careful attention to the sighting of the stove in relation to flue positions and existing fittings positions.

In replacement situations it may well be necessary to blank off the existing through roof flue position and cut a fresh one to suit the new location and comply with our instructions on flue design.

ABOUT THE APPLIANCES

Generally described as a space heater or space heater and cooker, which burns diesel oil in a controlled

manner utilizing a chimney to discharge the products of combustion.

The appliance generates heat from burning oil mixed with air in a vaporizing pot located in the bottom of the stove.

Once the appliance has been ignited, oil goes into the pot at a steady and controlled rate via a gravity feed which is metered by the OIL CONTROL VALVE; the oil flow can be controlled from minimum to maximum or any setting in between determined by the set position of the oil flow control knob.

Air is sucked into the pot by the natural action of the negative pressure in the chimney.

To allow the chimney to work correctly it is essential that you have adequate, unrestricted ventilation into the area where the stove is situated.

The amount of oil that can be successfully burned is directly proportional to the amount of air that the chimney can draw into the pot and so to achieve adequate combustion a balanced and appropriate flow of both oil and air is required.

The stove will provide space or combined space and water heating and in some cases cooking as well.

Where cooking and water heating are combined one feature will inevitably effect the other.

There are different versions of each appliance within the total range.

Some of the appliances are supplied as Dry, Small Boiler and Large Boiler versions namely B1 Half Pod, B1 Oven and B2.

Some of the appliances are supplied just as Dry and Large Boiler versions namely Corner Stove and Corner Oven Stove.

The Back Cabin Cooker can be supplied with or without a small boiler for domestic hot water heating only.(1kw)

All of the boilers are high water content and suitable for pumped or gravity systems and pressurised or open vented systems ASSUMING THAT THEY ARE INSTALLED BY SUITABLY QUALIFIED PERSONS.

All the appliances are fitted with a descaling device which should be rotated on a two weekly cycle to descale the oil inlet pipe.

Where applicable, appliances must not be operated with the glass front door opened or cracked, or without the lighting port plug fitted.

Where applicable, the door glass may require light cleaning occasionally depending upon the continuous running time of the stove.

Appliances must be securely bolted down to resist impact or collision and must be level in both directions.

All the appliances are supplied with clamp down brackets except the Back Cabin Cooker which must be fastened down through the foot plates.

The top of the appliances can be used for warming and cooking.

The oven appliances have a comprehensive range of cooking facilities with both oven and hot plate cooking available.

Some appliances can also be supplied with a coal kit, which just like a solid fuel stove, coal effect will only be available when the stove is running at maximum or near maximum performance.

Suitable deck flanges, flue systems and anti-downdraft cowls must be used.

CONTROLS

The output of the stove is regulated by the amount of oil allowed to go into it and this function is controlled by the -:

OIL CONTROL VALVE (O.C.V.), Turning the knob anti clockwise controls the oil flow.

2. SAFETY.

Take care to make sure that all safety and ventilation issues are adequately addressed.

FUMES

Always fit a suitable Smoke and Carbon Monoxide alarm within 1.5meters of the appliance.

Make sure that the function is checked on regular basis. (weekly)

Make sure that the alarm can be heard in the sleeping quarters.

Here are the main causes of fume or smoke to leak from the stove.

- The chimney is blocked.
- There are too many bends in the chimney.
- The above deck chimney extension is not high enough.
- The boat is moored in a position near to high buildings or trees and downdraughting is occurring.
- The chimney or parts of it are not airtight.

- There are unusually strong cross winds.

If down draughting occurs turn the appliance off until the winds subside and do not attempt to re-ignite the appliance until it has completely cooled down.

When it has cooled down, before attempting to ignite the appliance remove the catalyser and examine the base of the pot to make sure that there is no oil left in the pot, if there are signs of oil in the pot do not attempt to ignite the appliance until it has been completely dried out.

FIRE

Fire can be caused by a variety of potential danger points and because of the space limitation on boats; this risk is ever present and must be adequately assessed.

The main danger is the effects of heat from the stove on combustible materials and boat occupants.

Make sure that all combustibles are adequately protected from the effects of heat radiation.

Appliances must stand on a fireproof base of minimum thickness 30mm or a purpose made stand.

Floors in front of the stove must have suitable fire protection.

Built in stove heat shields should not be removed under any circumstances.

BURNS

During normal, day-to-day use, many parts of the stove, pipe work, and chimney will become too hot to touch.

Hot surfaces must be adequately protected to prevent anyone falling on to, or touching them.

Suitable fireguards for the appliance and chimney must be fitted.

Fireguards must comply with BS6539.

Always use heatproof gloves when working on or near to a hot stove.

CLEARANCES FROM COMBUSTIBLES

The appliances must be fitted in line with the distances specified in the tables.

All hearths and fireplaces must be made from non-combustible materials and adequately designed for the job.

CLEARANCES FROM COMBUSTIBLES-FLUE PIPES

Flue pipes must be fitted in line with the distances specified in the table and must be suitable for the individual application.

Any combustible materials within the specified distances from the appliances must be protected by a suitable heat shield.

Protection can be gained by the use of -:

- Sheet metal heat shields and spacers.
- Heat resistant boards such as TAC board.
Combustible materials can be-:
- Wooden furniture.
- Curtains.
- Wooden panels or frames adjacent to the flue pipe or where it passes through the deck of the boat.
- Carpet or flooring close to the stove.
- Items near to the stove, which could fall onto it and ignite, should the boat suffer a slight impact or collision.

VENTILATION.

Ventilation plays a vital role in the fitting and sighting of any stove.

The provision of ventilation for these appliances is adequately covered by the requirements of the boat safety scheme.

25cm sq. minimum permanent ventilation, directly to outside air, must be provided.

FLOODED VAPOURIZING BURNER POTS.

When attempting to light any of the appliances, make sure that the pot is not flooded with oil by looking into the base of the burner.

If it is flooded remove the excess oil.

Never try to relight a hot stove; wait until it has cooled down.

Hot oil vapour is explosive.

Never try to light a flooded pot.

SECURELY FIX THE APPLIANCE

The stove must be securely fastened down so that it can resist impact or collision and it must be level in both directions.

Level the stove in both directions when the vessel is midway between its maximum and minimum trim conditions.

Bubble appliances must not be fitted if the maximum angle of trim exceeds 0.75 deg forward to aft or port to starboard.

Only suitably qualified persons can install unvented plumbing systems.

A suitable and serviceable fire extinguisher should always be readily accessible.

3. CHIMNEY

This is the one of the most interesting problems the installer has to deal with and as the chimney affects most aspects of running the stove, we take time here to list the following information for your consideration.

The power, (*suck or vacuum the chimney can develop*) depends upon the following-:

THE HEIGHT.

THE DIAMETER.

THE TEMPERATURE OF THE GASSES IN IT.

THE RESISTANCE OF THE INNER SURFACE OF THE FLUE PIPE OR PIPES.

THE TYPE OF TERMINAL.

THE PREVAILING ATMOSPHERIC CONDITIONS.

It is obvious that on a boat all the above elements are in short supply.

Normally, we have low flues which are small in diameter and generally not very well insulated, coupled with all these problems we have another one, which is that the boat moves across constantly changing surroundings, through locks, into headwinds and crosswinds, all creating major opportunity for down draughting to occur.

Any bend in any part of the chimney or roughness on the internal chimney wall will slow down the velocity of rising gases and reduce the effectiveness of the chimney.

Any slight reduction in the flue gas temperature will reduce the chimney vacuum or pull, hence when the stove is slowed down for all night burning, as the flue gas cools down the chimney vacuum reduces and as the chimney vacuum drops, the stove may well start to burn sooty. This problem is highlighted even more during very cold weather when the chimney can cool down even faster. In these situations careful attention to servicing and low fire setting is essential.

THE CHIMNEY RULES.

1. Always use a top outlet for flue pipe take off.
2. Always try to get the stove as low as possible in the boat, this will allow installation of maximum length flue pipe.
3. Clean or have the chimney cleaned regularly. (Frequency depends upon type of fuel and length of time used).

4. FUEL SUPPLY.

There are several problems relating to diesel fuel supply, which need be adequately addressed.

WAXING

Cold weather waxing or thickening alters the flow characteristics of diesel.

An adequate fuel feed supply can turn into an inadequate one when the temperature starts to fall.

The worst scenario is fuel feed pipe 50-60 feet long in 8mm dia pipe.

The best-case scenario is a fuel pipe 4 feet long in 10mm dia with insulated lagging.

AIR LOCKS

Air lock in oil feed pipe work must be avoided.

The pipe work must slope down to the appliance and be clipped level at 500mm intervals to prevent sagging.

Any rises in the pipe work will cause air locks on commissioning and after future oil run out situations, if it is not possible to run the pipe work in a steady slope then where changes occur a vertical venting leg should be fitted.

TRIM

Bubble appliances must not be fitted if the maximum angle of trim exceeds 0.75 deg forward to aft or port to starboard.

Level the stove in both directions when the vessel is midway between its maximum and minimum trim conditions.

A minimum pressure head of 254mm (10") is required.

This head is measured from the base of the oil tank to the top of the oil control valve. In some cases this head can be affected by the ballast or trim of the boat.

Take great care to try out all the different ballast and trim possibilities to make sure that adequate oil feed is always available at the outlet end of the fuel pipe before it enters the oil control valve at the stove.

TANK

If the stove is fitted at the bow of the boat, a bow tank is recommended.

The tank should comply with the requirements of the boat safety scheme and have:-

- A conveniently sized filler
- A means of venting.
- A conveniently located, easily visible, contents gauge.
- An isolation valve
- An easily replaceable cartridge filter.
- A suitable and substantial water trap

Do not use glass filter bowls, they are not acceptable under the boat safety scheme.

Make sure that your fuel supplier supplies you with appropriate fuel for wintertime running.

OIL LINE

The oil feed line starts after the fuel filter and proceeds to the point of entry, which is where the oil line goes into the cab or saloon of the boat.

The diameter of the oil line is dependent upon the length of run. See 3-2 on waxing and make sure that you have suitably sized compression fittings available.

At this point it is necessary to fit a 60 DEG C, remote sensing fire valve, designed to shut off the oil supply, should a fire occur near to the stove.

If the bubble stove is fitted up to the first bulkhead it will be necessary to fit the isolation valve outside the cabin or saloon of the boat. 5. Make sure that you have purged the oil feed line of all air and there is a steady and constant flow of oil available at the inlet to the oil valve. Make sure that all or any oil isolation devices are turned to the on position. Remember that the oil valve needs a min head of 300mm for gravity feed. When feeding from rear tanks with appliances fitted forward always be aware of the forward - aft trim of the vessel.

Do not use syphonic oil feeds to Bubble Appliances, oil should be fed by gravity or pumped via an appropriate pressure pump = head pressure less than 99mbar.

WATER CONTAMINATION

Because of the high risk of fuel contamination with water, we strongly recommend the fitting of a **high volume water trap**, in the oil supply line.

REMOTE SENSING FIREVALVES

There are two situations where a remote sensing firevalve should be fitted.

1. For fire protection fit a 60 deg C valve.
2. For over boil protection fit an additional 90 deg C valve.

For fire protection a remote sensing fire valve should be fitted as detailed in fig 3.

Run the capillary tube with the oil line up to the stove and carefully fit the sensing phial as follows

B1 Half Pod, B1 Oven and B2 at a low level fitted on two 15mm pipe clips.

Corner Stove and Corner Oven Stove on 15mm pipe clips in front of the drip tray on the fireplace hearth, directly in front of the combustion air restrictor.

Before it is fitted try the fender on the stove to make sure that the fender does not foul the sensing phial.

The sensing phial may be visible through the bottom of the fender, to mask it, paint it with matt black paint available from our sales desk.

When fitting the fire valve make sure that where the capillary and oil line go through the bulkhead in separate sleeved tubes, so that the capillary can be withdrawn separately should it ever need replacing.

For fitting of long oil feed lines which pass through bulkheads and various other parts of the boat it may well be necessary to fit more than one fire valve, especially where the oil line passes through an area where a fire could occur i.e. kitchen area etc.

ISOLATION VALVES.

Two isolation valves are required, one fitted directly into or close to the oil control valve to allow you or the service man to turn the oil off should the need arise, and one fitted directly into the oil tank before the fuel filter.

Always turn off the oil isolation valve serving the appliance before leaving the vessel unattended.

SLEEVING.

Where the oil line goes through the boat superstructure a suitable bulkhead fitting must be used.

OVERBOIL OR OVERHEAT PROTECTION OF THE APPLIANCE.

Where appliances are not fitted with an automatic thermostat an additional 90 DEG C, remote sensing

fire valve must be fitted directly in front of the oil control valve and the sensor from this valve has to be attached to the water jacket or the hot outlet pipe from the boiler.

The valve is calibrated to shut the oil supply down should the water temperature exceed 90 Deg C.

There is a re set button on the remote sensing fire valve which needs to be pressed in to re set the valve after it has tripped off.

4A LIGHTING & COMMISSIONING

A relevant oil control valve catalogue is supplied with each appliance and details of high and low fire adjusting screws are illustrated.

On the Toby valve the low fire screw is clearly visible as per TOBY MANUAL FIG 2

Before trying to light the burner in cold weather it is advisable to pre heat the flue pipe before lighting.

There are two different types of burner fitted to Bubble appliances.

The FB style burner fitted to the **B1 Half Pod, B1 Pie Pod and B2.**

The Socomef burner fitted to the **Corner Stove, Corner Oven Stove** and the **Back Cabin Cooker see sec 4B for lighting Socomef burners.**

1. LIGHTING B1 HALF POD, B1 PIE POD AND B2

When attempting to light the stove these are the rules, which must be followed.

1. Always make sure that the pot is **not** flooded with oil by looking down into the base of the pot.
2. Never try to light the stove if it is flooded with oil.
3. Always check that oil has not leaked from the appliance.
4. Do not light the stove and leave it unattended until it is settled down and stabilized into constant blue flame combustion on low fire. (This could take 10 to 20 minutes.)

On first light up it is advisable to warm the flue pipe up to try and create chimney draft.

Two Ways to Light the Stove

1. Through the lighting port B1 and B2 appliances only,
or
2. Directly into the base of the pot by removing the catalyser.

Lighting into the base of the Pot

On the first light up you may find this option better, as it is possible to see the oil trickle in to the pot more easily.

Use a heatproof glove when putting the catalysers back into the pot and it is important to replace them quickly whilst the flame is small.

Make sure that the oil is turned off.

Open the front door.

Remove the optional coal kit if fitted.

Remove the catalyser.

Turn the oil on and allow a small pool of oil to flow into the pot about the size of a small biscuit, **then turn the oil off.**

Note that on first light up it may take a few minutes for the oil to reach the pot as it has to fill the pipework before reaching the pot, take care not to allow excess oil to flow into the pot.

Light a small piece of firelighter and drop it into the oil, allow a few seconds for it to get going and then replace the catalyser and coal kit if fitted, and close the door.

Wait for approx. 1 minute until the pool of oil is alight and then **turn the oil on** to minimum setting no 1.

Watch the appliance for a few minutes and you will see the flame establish and settle down into blue flame combustion.

Allow the burner to run for a further 10 minutes before turning the appliance up to the higher settings.

If at any time during the ignition process large amounts of flame can be seen, turn the oil off immediately and wait until the flames die down before putting the oil on again at minimum setting.

Manual Lighting through the Lighting Port B1 and B2 appliances.

Check that the isolation valve is turned on.

Open the front door.

Remove the front apron on B1 Half Pod and B1 pie Pod.

Remove the lighting port plug by pulling it out of its tubular socket.

Turn the oil on to the first position via the flow control knob and allow a small pool of oil to flow into the pot about the size of a small biscuit.

Turn the oil off.

Cut a small piece of firelighter and stab it onto the spike.

Light it and push it into the lighting port tube, let the firelighter drop off the spike into the bottom of the pot.

Replace the lighting port plug back into the tube.

Close the front door.

Turn the fuel flow on again at the lowest setting

Watch the appliance for a few minutes until it settles down into blue flame combustion.

Allow the burner to run for a further 10 minutes before turning the appliance up to the higher settings.

If at any time during the ignition process large amounts of flame can be seen, turn the oil off immediately and wait until they die down before putting the oil on again.

Note there may be the occasional growl or audible vibration whilst the burner settles down into blue flame combustion.

COMMISSIONING THE HIGH & LOW FIRE, CHRYSTAL SERIES

Used in B1 Half Pod, B1 Pie Pod and B2

When the burner has established good blue flame combustion turn it up to half output. (Setting 3 on the fuel flow control knob) and let it stabilize.

Allow at least half an hour for the chimney to warm up thoroughly before making any adjustments to the high or low fire screws.

Turn the stove down onto minimum firing rate and let it stabilize.

After stabilization there should be a dull red glow in the lower catalyser with wispy blue flames flicking into and just over it.

If the flame falls into a dirty rolling yellow flame and the catalyser is not dull red then the low fire will need to be increased until it can support the required blue flame combustion.

To increase the low fire oil flow, screw the adjusting screw out by quarter turn increments.

When you are happy with the low fire, set the high fire.

Turn the oil flow knob up to setting 4, let the flame stabilize, and look at it, if it is stable and blue, turn it up slowly using the control knob, letting it stabilize after each movement, if the flame starts to go yellow with long flame combustion, it is running fuel rich and

the high fire screw needs adjusting to reduce the flow of oil. (Screw the adjuster screw in to reduce the high fire oil flow.)

Before adjusting the high fire screw, turn the flame down and let it stabilize in blue flame combustion, adjust the high fire screw by half a turn in and try turning the fuel flow up, if it is still fuel rich repeat the process until the high fire flame is running blue with just flicks of yellow in the tips.

To see a bubble stove running correctly see the following link

<https://www.youtube.com/watch?v=UqdQLFp3HkQ>

4B LIGHTING & COMMISSIONING THE BURNER SOCOMEF SERIES

1. LIGHTING CORNER STOVE, CORNER POD AND BACK CABIN COOKER.

When attempting to light the stove these are the rules, which must be followed.

1. Always make sure that the pot is not flooded with oil by looking down into the base of the pot.
2. Never try to light the stove if it is flooded with oil.
3. Always check that oil has not leaked from the appliance.
4. Do not light the stove and leave it unattended until it is settled down and stabilized into constant blue flame combustion on low fire. (This could take 10 to 20 minutes.)
5. Make sure that you have purged the oil feed line of all air and there is a steady and constant flow of oil available at the inlet to the oil valve. Make sure that all or any oil isolation devices are turned to the on position. Remember that the oil valve needs a min head of 300mm for gravity feed. When feeding from rear tanks with appliances fitted forward always be aware of the forward - aft trim of the vessel.
6. Do not use syphonic oil feeds to Bubble Appliances, oil should be fed by gravity or pumped via an appropriate pressure pump = head pressure less than 99mbar.

On first light up it is advisable to warm the flue pipe up to try and create chimney draft.

Lighting the Stove

Lighting the stove takes a little time and patience; the following procedure should be adopted.

In the case of the Corner appliances, open the front door and in the case of the Back Cabin Cooker remove the hot plate and top baffle to gain access to the

burner, note that the back cabin cooker has a lighting port fitted behind the lower ash pit door.

Remove the coal kit if it has been supplied with the stove.

Lift the inner mesh catalyser from the burner.



Look into the bottom of the pot and turn the oil on at full rate, allow oil to flow into the bottom of the pot to form a pool about the size of a small digestive biscuit and then turn the oil off.

Note that on first light up it may take a few minutes for the oil to reach the pot as it has to fill the pipework before reaching the pot.

Do not allow any depth of oil to build up.

Light a small piece of firelighter (about the size of a pineapple chunk) and place it into the centre of the oil pool.

Replace the mesh catalyser and the coal kit, if fitted and then leave the door slightly open whilst the firelighter gets the oil going.

After 30 to 40 seconds, you will notice the flame start to establish itself and spread around the bottom of the pot.

When this occurs, close the door or replace the baffle and top plate and then turn the oil on to its minimum setting.

After two or three minutes the flame should slowly change from yellow into blue flame combustion and settle down to a steady burn.

Note there may be the occasional growl or audible vibration whilst the burner settles down into blue flame combustion.

Allow the burner 10 - 15 minutes to stabilise and the increase the flow of oil as required, moving by one increment of the dial only.

Do not leave the appliance unattended during the lighting and stabilising procedure.

COMMISSIONING THE HIGH AND LOW FIRE SOCOMEF BURNERS.

Corner Stove, Corner Pod and Back Cabin Cooker.

Note that Back cabin Cookers are pre commissioned at the factory and do not need adjusting.

A relevant oil control valve catalogue is supplied with each appliance and details of high and low fire adjusting screws are illustrated.

On the Toby valve the low fire screw is clearly visible as per TOBY MANUAL FIG 2

When the burner has established good blue flame combustion turn it up to half output. (Setting 3 on the fuel flow control knob) and let it stabilize for a minute. Allow at least half an hour for the chimney to warm up thoroughly before making any adjustments to the high or low fire screws.

Turn the stove down onto minimum firing rate and again let it stabilize.

After stabilization there should be a dull red glow in the catalyser with wispy blue flames flickering just over the top of it, approximately level with the top of the pot.

If the flame falls into a dirty rolling yellow flame and the catalyser is not dull red then the low fire will need to be increased until the burner can support the required blue flame combustion.

When you are happy with the low fire, set the high fire.

Turn the oil flow knob up to setting 4, let the flame stabilize, and look at it, if it is stable and blue, turn it up slowly using the control knob, letting it stabilize after each movement, if the flame starts to go yellow with long flame combustion, it is running fuel rich and the high fire screw needs adjusting to reduce the flow of oil. (Screw the adjuster screw in to reduce the high fire oil flow.)

Before adjusting the high fire screw, turn the flame down and let it stabilize in blue flame combustion, adjust the high fire screw by half a turn in and try turning the fuel flow up, if it is still fuel rich repeat the process until the high fire flame is running blue with flicks of yellow in the tips.

On the Socomef pot, the high fire flame will be set approx. 40mm above the top of the pot.

NOTE THAT THIS PROCEDURE WILL NOT BE POSSIBLE IF THE CHIMNEY RULES HAVE NOT BEEN ADHERED TO.

THE HIGH FIRE SETTING WILL HAVE TO BE ADJUSTED IN LINE WITH THE AVAILABLE GENERATED CHIMNEY VACUUM IE

THE FLUE PIPE MUST BE A MINIMUM OF 1.8 METERS HIGH FOR LOW FIRE AND 2.1 METERS FOR HIGH FIRE.

INSTALLING ENGINEERS SHOULD NOT LEAVE THE APPLIANCE UNDER THE CONTROL OF THE CUSTOMER UNLESS THE APPLIANCE HAS BEEN CORRECTLY COMMISSIONED.

TO SEE HOW THE BURNER SHOULD OPERATE COMMISSIONING AND INSTALLING ENGINEERS SHOULD VISIT

<https://www.youtube.com/watch?v=UqdQLFp3HkQ>

This video shows a stove running from low to high fire and back to low fire. Note that this video is filmed on a normal house chimney and so it may not be possible to get exactly the same conditions on a typical boat flue as the fuel air ratio will not be exactly the same, hence the need for fine tuning the oil flow to the chimney air flow capability.

5. FIREPLACE.

Unless one is built into the appliance, always fit appliances on a suitable drip tray.

The possibility of oil drops leaking from the stove must be considered; a suitable oil drip tray must be fitted and designed in such a way, as it will contain any oil leaks or drips.

Normally the tray will cover the footprint of the stove, the oil valve and isolation device.

It will be oil tight and have a vertical up stand of at least 30mm. This should give a minimum containment volume of 2 litres.

It will be securely fastened down to the vessel and the appliance must be securely fastened down to the oil drip tray.

Make sure that drip trays are tested to ensure that they do not leak when filled with oil.

The hearth must be:-

FLAT - SECURE - FIREPROOF AND LEVEL IN BOTH DIRECTIONS.

Use materials, which are easy to keep clean and fireproof such as tiles, asbestolux or vermiculite boarding with a suitable weight resistant liner.

The vertical walls of the fireplace must also be made from fireproof materials.

Use fireproof, rockwool infill behind the fireplace panels to protect any combustible insulation materials

such as spray foam.

6. DISTANCES FROM COMBUSTIBLES (APPLIANCES)

Stove Type	ABOVE	SIDES.	BACK	FRONT	HEARTH Non Combustible Material
B1 HALF POD and OVEN VERSION	500	300	150 FROM HEAT SHIELD	300 to allow door opening.	30MM THICK x 100 projection at the front and sides
BOAT B2	600	300	150 FROM HEAT SHIELD	300 to allow door opening.	30MM THICK x 100 projection at the front and sides
CORNER and OVEN VERSION	500	75	100 FROM HEAT SHIELD	300 to allow door opening.	30MM THICK x 100 projection at the front.
BACK CABIN COOKER	500	150	100 FROM HEAT SHIELD	300 to allow door opening.	25MM THICK x 150 projection at sides

7. DISTANCES FROM NON COMBUSTIBLES (APPLIANCES)

Stove Type	ABOVE	SIDES.	BACK	FRONT	HEARTH Non Combustible Material
B1 HALF POD and OVEN VERSION	300	150	150 FROM HEAT SHIELD	300 to allow door opening.	30MM THICK x 100 projection at the front and sides.
BOAT B2	300	150	150 FROM HEAT SHIELD	300 to allow door opening.	30MM THICK x 100 projection at the front and sides.
CORNER and OVEN VERSION	200	150	25 FROM HEAT SHIELD	300 to allow door opening.	30MM THICK x 100 projection at the front and sides.
BACK CABIN COOKER	500	75	50 FROM HEAT SHIELD	300 to allow door opening.	25MM THICK x 75 projection at sides

Note that the back cabin cooker can have the oil control valve fitted to the rear or the left hand side in each case the positioning of the valve will affect the fireplace and spacing considerations, see sizes of cooker to establish requirements.

8. DISTANCES FROM COMBUSTIBLES (FLUE PIPES)

For all appliances-:

1. Single skin flue pipes. Horizontal Distance = 50mm **when fitted within the deck flange** at the top of the chimney system, protected by the fire stop spacer.
2. Single skin flue pipes. Horizontal Distance = 150mm **when exposed in the saloon or living space.**
3. Twin Wall Insulated flue pipes. Horizontal Distance = 30 mm for insulated flue pipe systems.

9. ILLUSTRATIONS

FIG 1. STOVE DISTANCE FROM COMBUSTIBLES

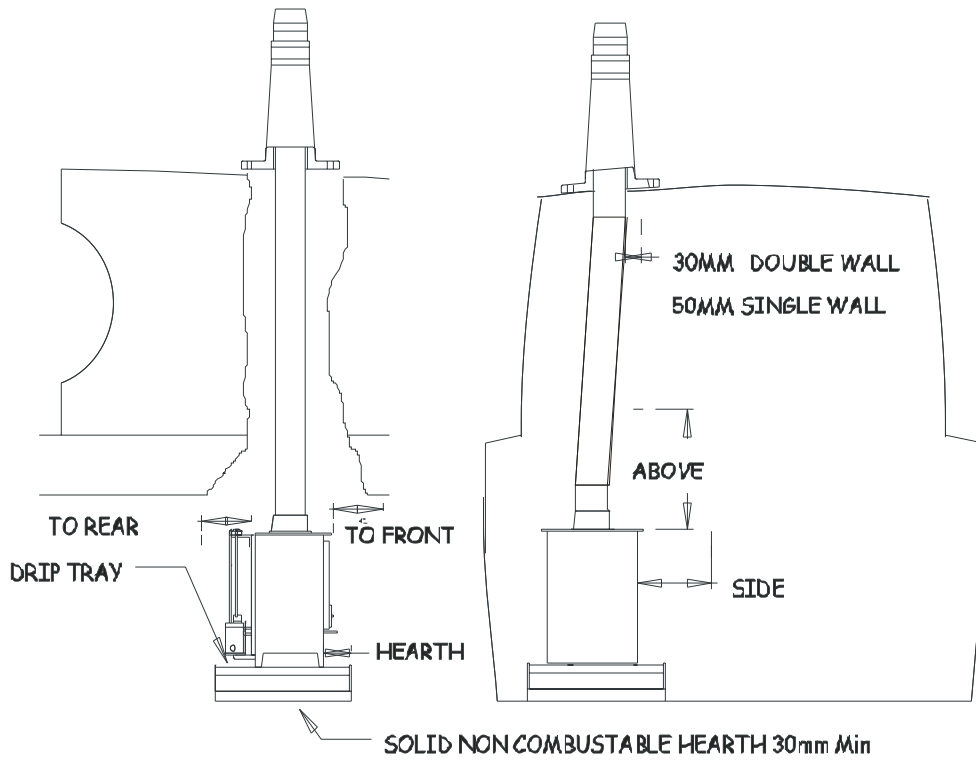

FIG 2 BUBBLE MK1 FABRICATED DECK FLANGE LAYOUT

Note that there is mk3 system which is now available and detailed on our web site.

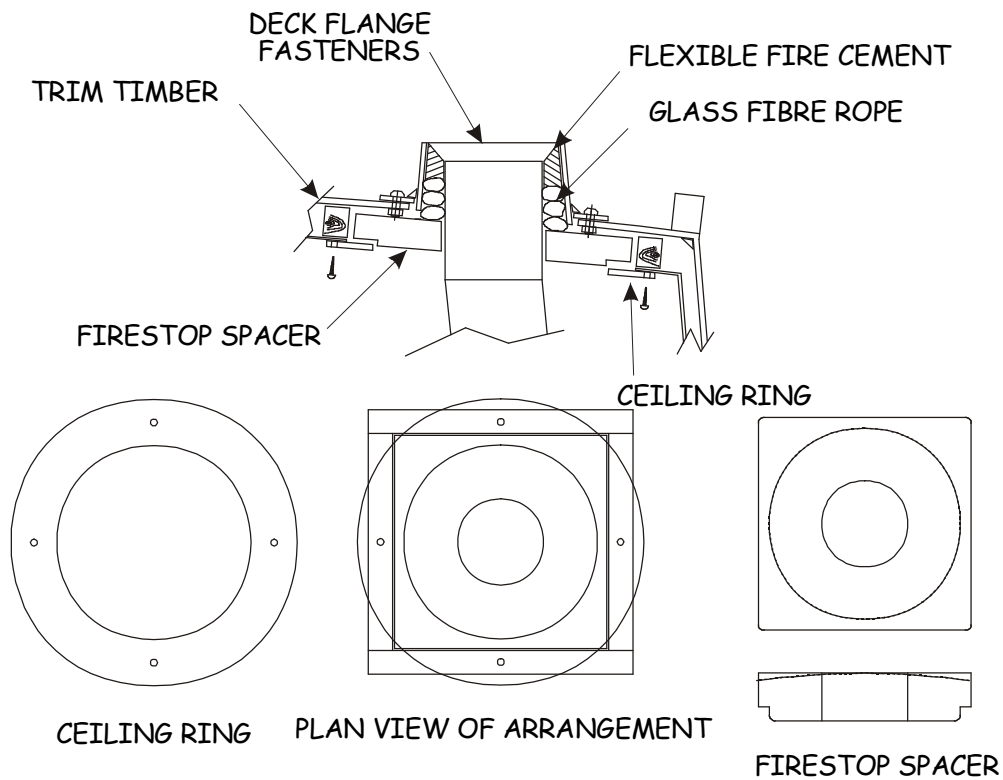
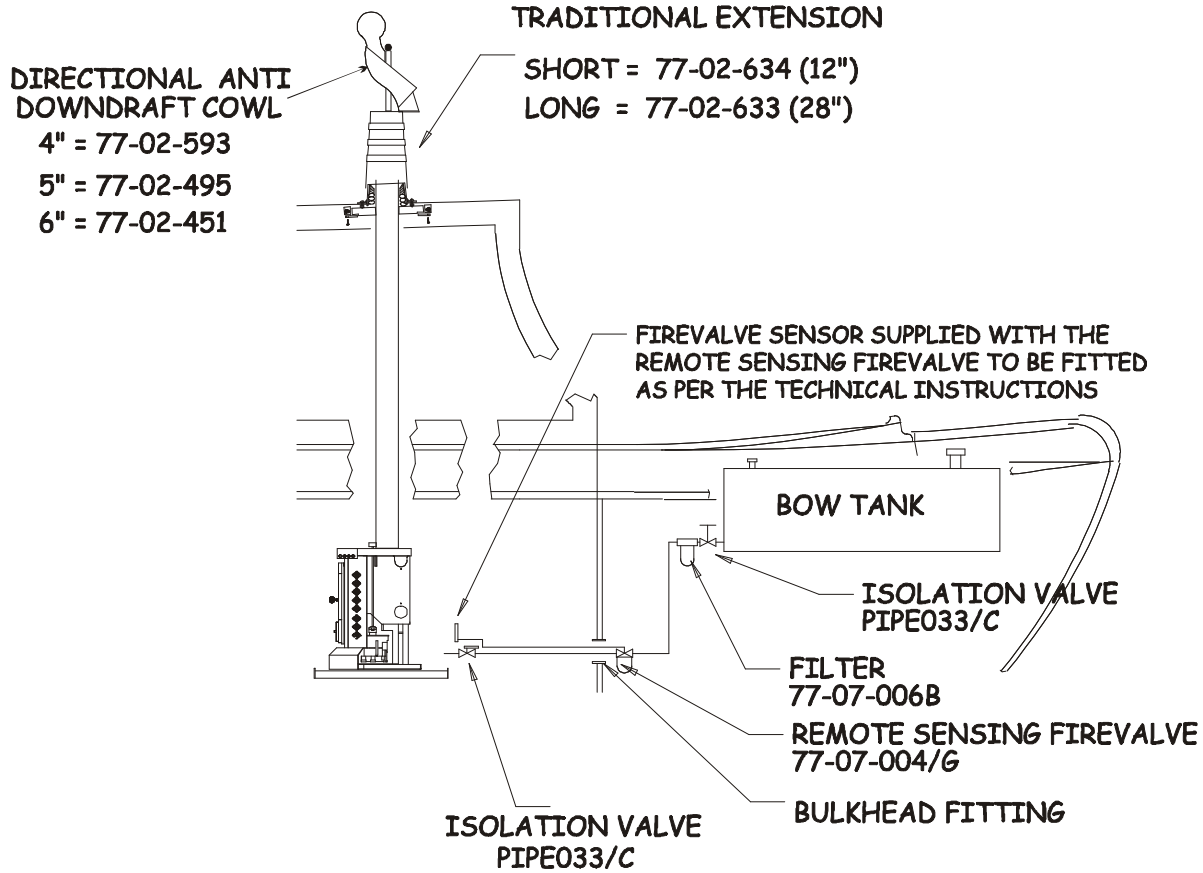

FIG 3 TYPICAL OIL FEED LAYOUT



COPYRIGHT HARWORTH HEATING LTD 080800

FIG 4 TYPICAL PUMING LAYOUTS

Drq 1

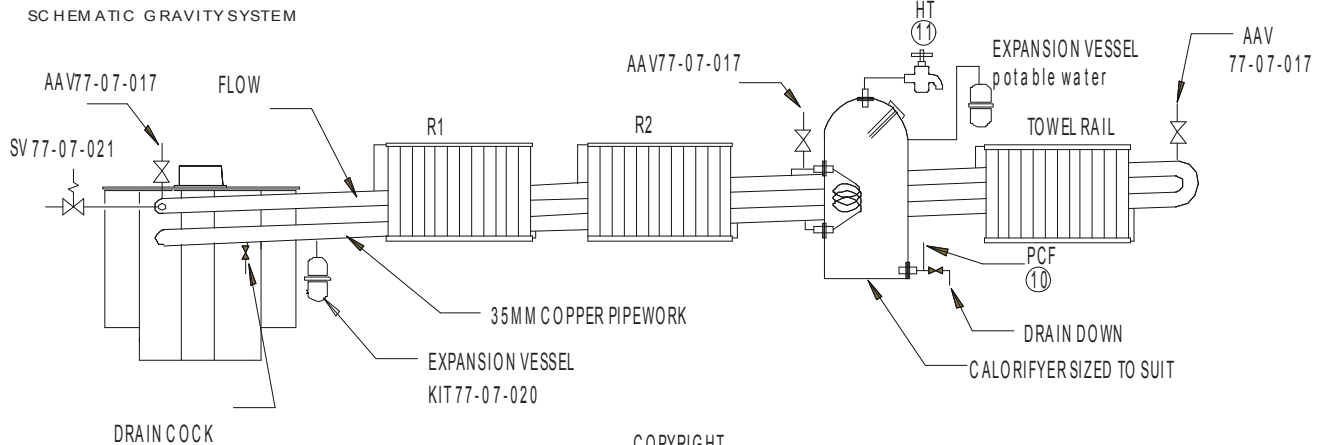

COPYRIGHT BUBBLE PRODUCTS 2013

Drg 2

SCHEMATIC PUMPED SYSTEM ISS 2 OF 28-10-17

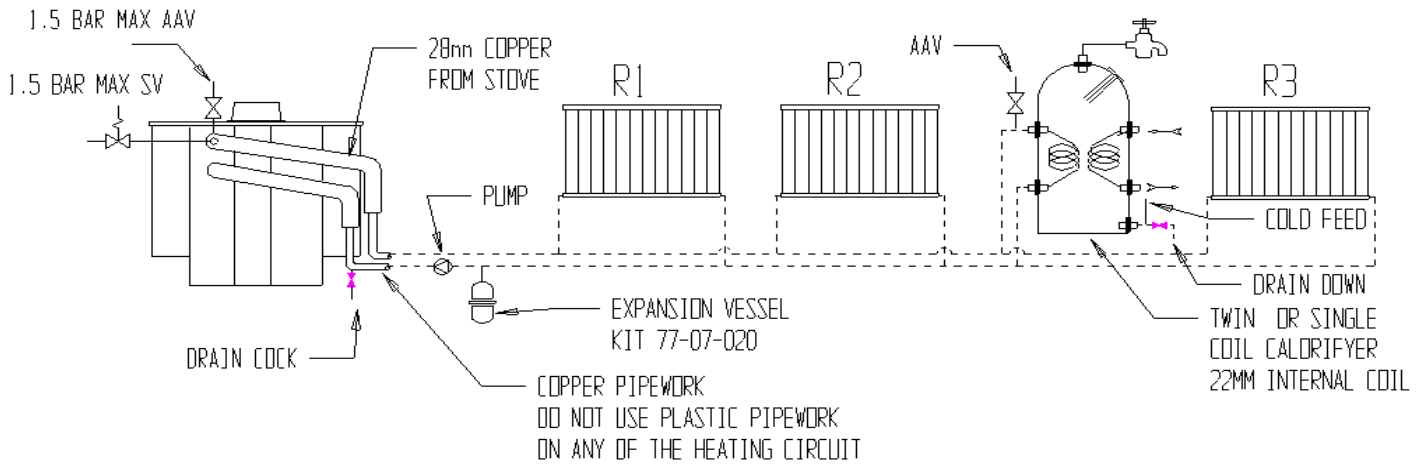

Drg 3

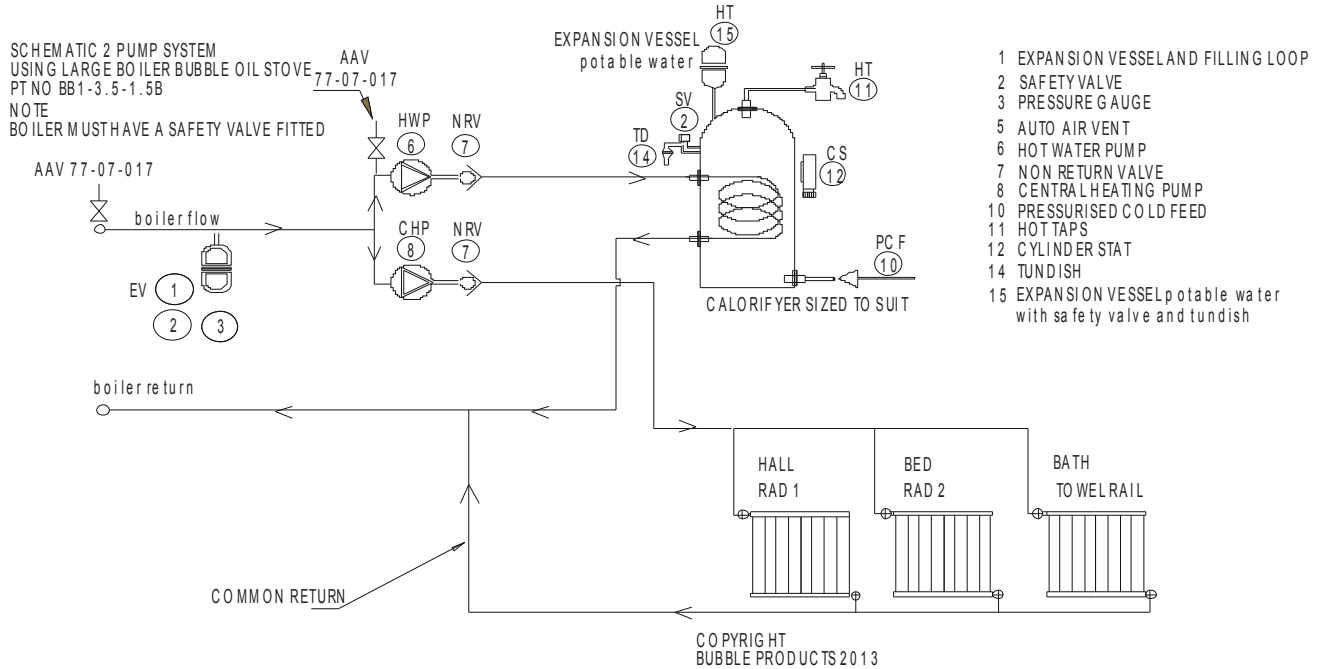

10. STOVE DIMENSIONS

10-1 BB1 HALF POD AND PIE POD DIMENSIONS

Note that the B1 Pie Pod has the same footprint dimensions but the vertical height is 830mm.

**B1 HALF OIL POD OF 12-02-15
OVERALL DIMENSIONS
BOILER AND NON BOILER VERSIONS**

**.WEIGHT 35.KG NON BOILER
.WEIGHT 45.KG SMALL BOILER
.WEIGHT 50.KG LARGE BOILER**

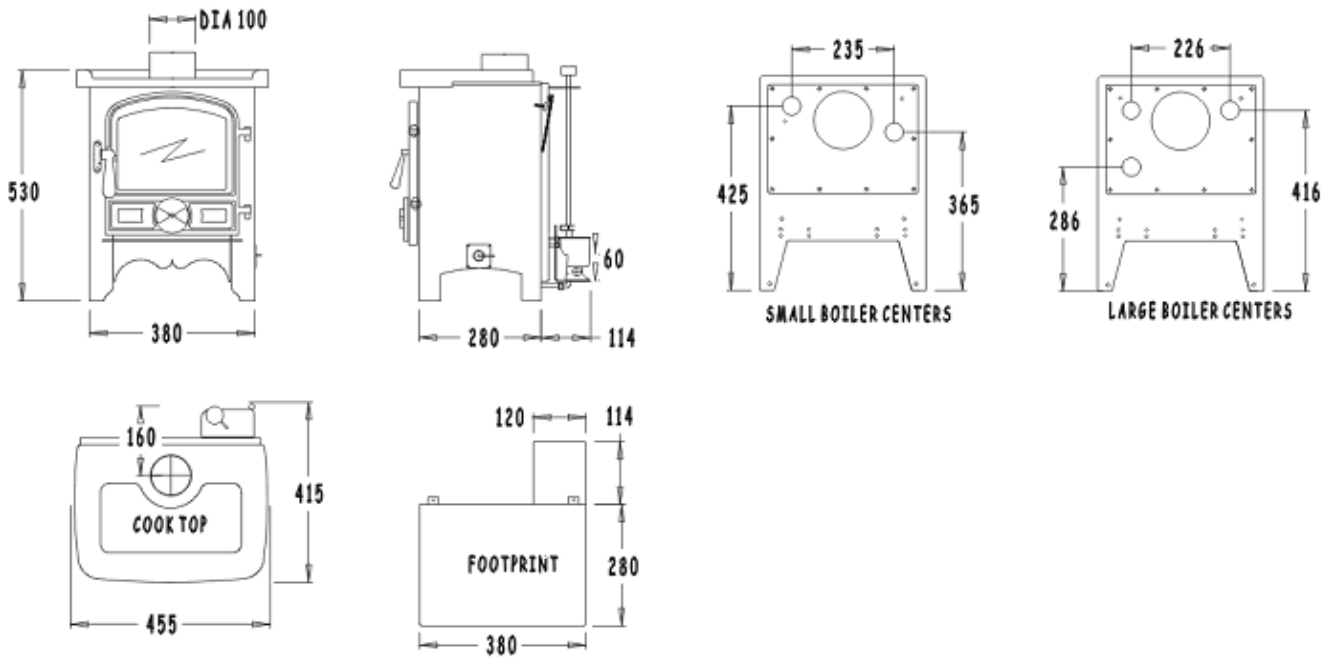

10-2 CORNER STOVE AND CORNER PIE POD DIMENSIONS

Note that the Corner Pie Pod has the same footprint dimensions but the vertical height is 840mm.

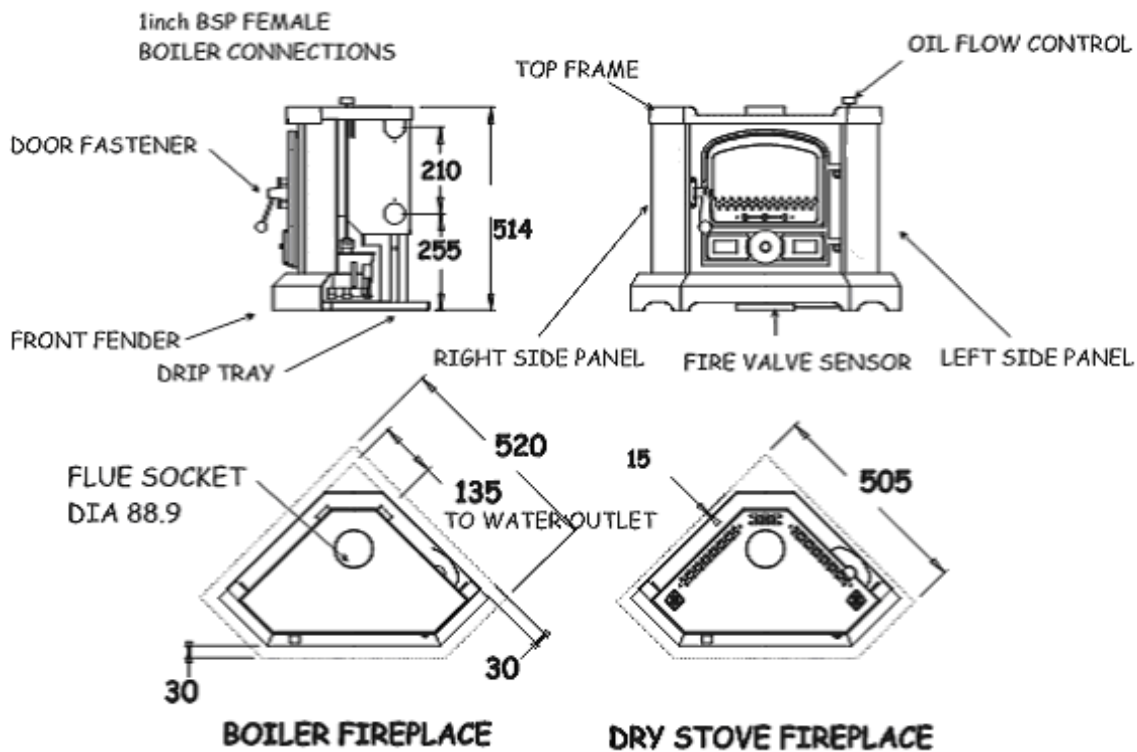

10-3 B2 STOVE DIMENSIONS

Note that the B2 Pie Pod has the same footprint dimensions but the vertical height is 830mm.

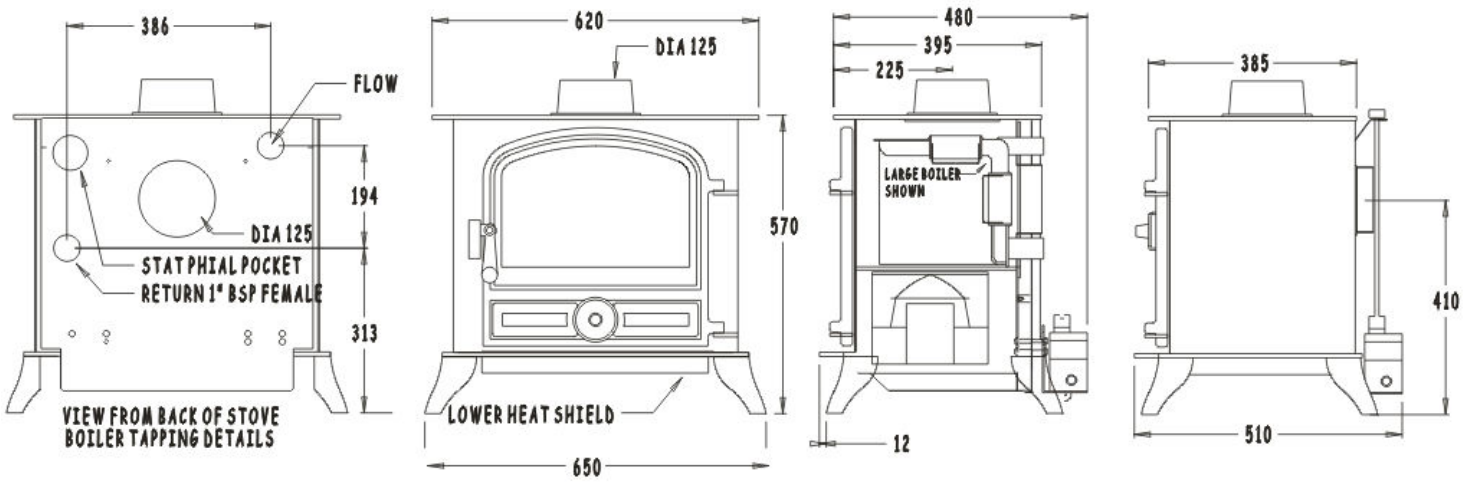

10-4 BACK CABIN COOKER DIMENSIONS

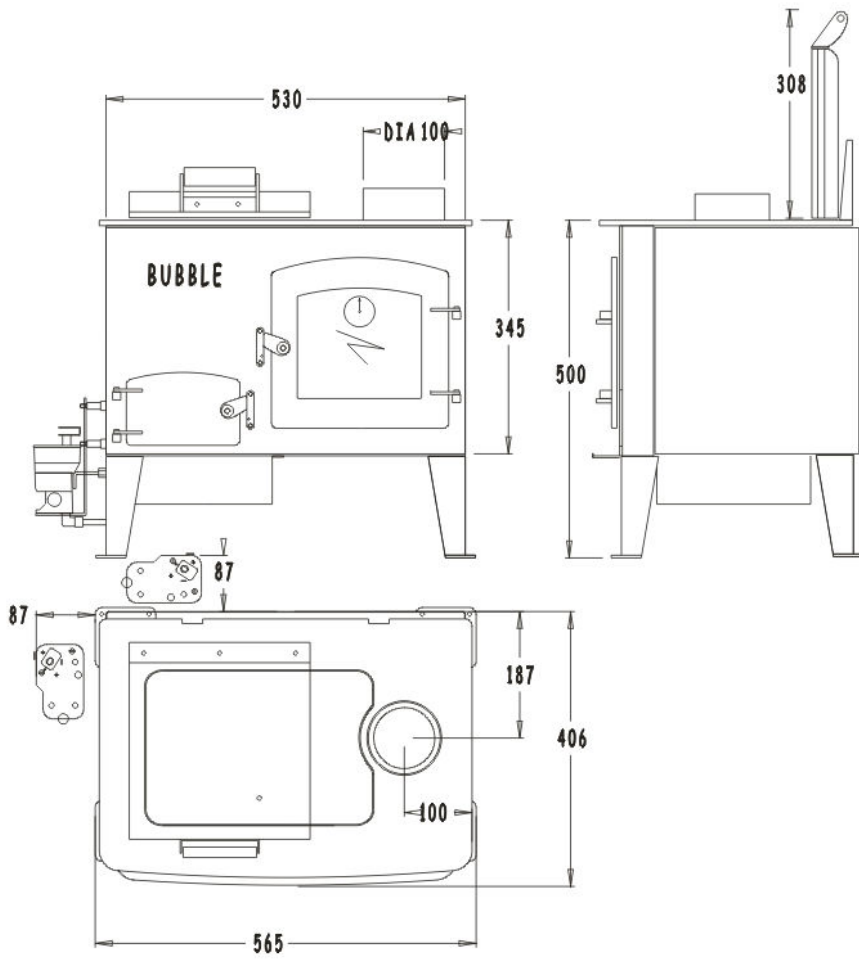

11. OIL CONSUMPTION RATES

		MAX HEAT OUTPUT TO WATER	MAX HEAT OUTPUT TO SPACE	MINIMUM OIL FLOW CC'S PER MIN	MAXIMUM OIL FLOW CC'S PER MINUTE
--	--	--------------------------	--------------------------	-------------------------------	----------------------------------

B1 HALF POD & OVEN DERIVATIVE					
Free Standing	From 1.6kW to 5kW		5kW	4 = (1.6kW)	12 = (5kW)
Free Standing	From 1.6kW to 5kW	2kW	3kW	4 = (1.6kW)	12 = (5kW)
Free Standing	From 1.6kW to 6kW	5kW	2kW	4 = (1.6kW)	13 = (6kW)

CORNER STOVE & OVEN DERIVATIVE					
Free Standing	From 1kW to 4kW		4kW	3 = (1kW)	10 = (4kW)
Free Standing	From 1kW to 4kW	3kW	1kW	3 = (1kW)	10 = (4kW)

BUBBLE 2					
Free Standing	From 1.6kW to 5kW		5kW	4 = (1.6kW)	13 = (5kW)
Free Standing	From 1.6kW to 8kW		8kW	4 = (1.6kW)	16 = (8kW)
Free Standing	From 1.6kW to 8kW	3kW	5kW	4 = (1.6kW)	16 = (8kW)
Free Standing	From 1.6kW to 8kW	9kW	2kW	4 = (1.6kW)	22 = (11kW)

BACK CABIN COOKER					
Free Standing	From 1.6kW to 5kW		3kW	4 = (1.6kW)	7 = (3kW)
Free Standing	From 1.6kW to 5kW	1kW	2kW	4 = (1.6kW)	7 = (3kW)

© HARWORTH HEATING LTD 30.6.98

This publication may not be copied by any means, without written permission from the authors.

These products are subject to continuous development and improvement and it is consequently acknowledged that due to this process there may be some omissions and errors.

This publication is intended only to assist the reader in the use of this product and therefore Harworth Heating Ltd shall not be liable for any loss or damage whatsoever arising from the use of any information, error or omission found in this publication.

The appliances mentioned in this publication can only be installed and serviced by approved personnel.

Approved personnel means that they must HAVE BEEN SUITABLY TRAINED, if there are any

reliability issues reported back to **Harworth Heating** or **Bubble Products**, the installing engineer will be responsible for carrying out any rectification work.

For details of suitable training courses contact: - www.oftec.org

12. NORMATIVE REFERENCES

Boat installation work comes under the control of: -
The Boat Safety Scheme.

This scheme provides statutory requirements and associated EN / BS Standards for most aspects of installation work on boats.

Further information and a copy of the requirements can be obtained from:-

www.boatsafetyscheme.com

Where guidance for oil fired appliances is not readily available from the Boat safety Scheme publication, we then point out a list of standards which pertain to domestic installations and which are generally covered by the latest version of the English Building Regulations Doc J.

When read in conjunction with:-

1. Our installation instructions.
2. The Boat Safety Scheme rules.
3. The other standards detailed, enough information should be provided to allow for a safe installation.

BS 5440	Flues.
BS 6999	Flues
BS 7840	Fuel Hoses.
BS EN1057	Copper Tubes.
BS1344 Part 3 1988 ISO8290 1987	Flues.
BS EN 1443:2003	Chimneys - General requirements.
BS EN1856 part 1 replacing BS 4543	Flues.
BS EN1856 part 2 & BS 715 1993	Flues.
BS 1945: 1971	Stove door
BS EN 10296-1	Steel tubes
BS ISO 10088:2001	
BS EN ISO 9094-2003	
BS EN 10297-1	Steel tubes
BS EN 13384-1	Chimneys
BS EN 10088-1:2005	Stainless steels - Part 1: List of stainless steels

INSTALLATION & GENERAL INSTRUCTIONS



Silent Simplicity just for you!

MARINE OIL STOVES ©

ISSUE 15 @ 22-06-18

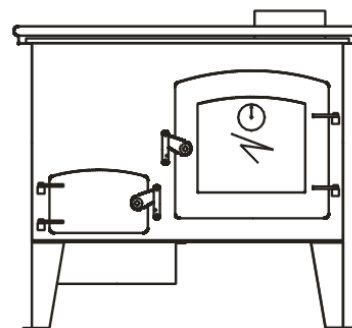
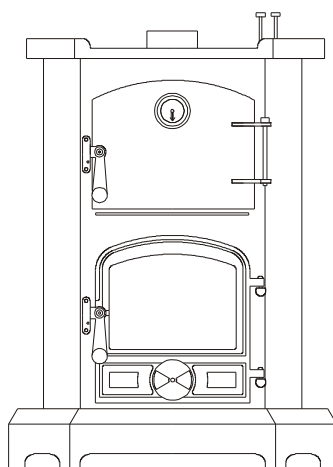
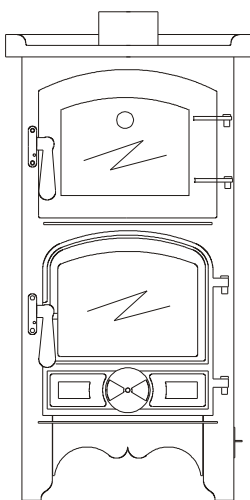
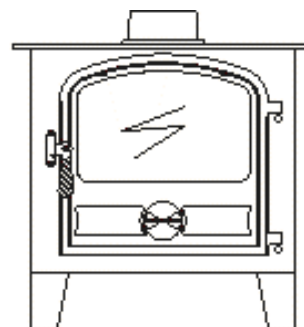
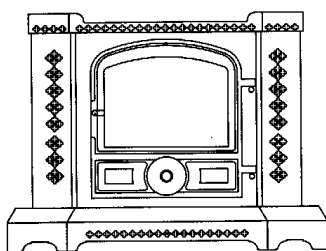
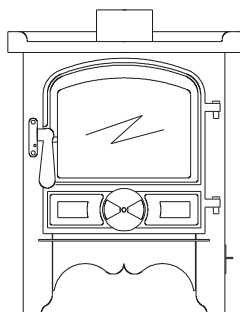

www.harworthheating.co.uk

INDEX

1. BEFORE STARTING THE JOB.	3
FITTING OPTIONS.	3
ABOUT THE APPLIANCES	3
2. SAFETY.	4
FUMES	4
FIRE	4
BURNS	4
CLEARANCES FROM COMBUSTIBLES	4
CLEARANCES FROM COMBUSTIBLES-FLUE PIPES	5
VENTILATION.	5
FLOODED VAPOURIZING BURNER POTS.	5
SECURELY FIX THE APPLIANCE	5
3. CHIMNEY	5
THE HEIGHT.	5
THE DIAMETER.	5
THE TEMPERATURE OF THE GASSES IN IT.	5
THE RESISTANCE OF THE INNER SURFACE OF THE FLUE PIPE OR PIPES.	5
THE TYPE OF TERMINAL.	5
THE PREVAILING ATMOSPHERIC CONDITIONS.	5
THE CHIMNEY RULES.	6
4. FUEL SUPPLY.	6
WAXING	6
AIR LOCKS	6
TRIM	6
TANK	6
OIL LINE	6
WATER CONTAMINATION	6
REMOTE SENSING FIREVALVES	7
ISOLATION VALVES.	7
SLEEVING.	7
OVERBOIL OR OVERHEAT PROTECTION OF THE APPLIANCE.	7
4A LIGHTING & COMMISSIONING	7
1. LIGHTING B1 HALF POD, B1 PIE POD AND B2	7
COMMISSIONING THE HIGH & LOW FIRE, CHRYSTAL SERIES	8
4B LIGHTING & COMMISSIONING THE BURNER SOCOMEF SERIES	9
1. LIGHTING CORNER STOVE, CORNER POD AND BACK CABIN COOKER.	9
COMMISSIONING THE HIGH AND LOW FIRE SOCOMEF BURNERS.	10
5. FIREPLACE.	10
6. DISTANCES FROM COMBUSTIBLES (APPLIANCES)	11
7. DISTANCES FROM NON COMBUSTIBLES (APPLIANCES)	11
8. DISTANCES FROM COMBUSTIBLES (FLUE PIPES)	11
9. ILLUSTRATIONS	12
FIG 1. STOVE DISTANCE FROM COMBUSTIBLES	12
FIG 2 BUBBLE MK1 FABRICATED DECK FLANGE LAYOUT	12
FIG 3 TYPICAL OIL FEED LAYOUT	13
FIG 4 TYPICAL PUMBING LAYOUTS	13
10. STOVE DIMENSIONS	14
10-1 BB1 HALF POD AND PIE POD DIMENSIONS	14
10-2 CORNER STOVE AND CORNER PIE POD DIMENSIONS	15
10-3 B2 STOVE DIMENSIONS	15
10-4 BACK CABIN COOKER DIMENSIONS	16
12. NORMATIVE REFERENCES	18

If you have any difficulties please phone our technical help line on-:

01302 742520 fax 01302 750573

e-mail contact@bubbleproducts.co.uk

<http://www.bubbleproducts.co.uk>

1. BEFORE STARTING THE JOB.

THE FOLLOWING NOTES PROVIDE INFORMATION FOR INSTALLATION OF THE FOLLOWING APPLIANCES.

Boat Bubble No 1 AND HALF POD, Dry Small and Large Boiler Appliances

Boat Bubble No 2 Dry Small and Large Boiler Appliances

Marine Corner Bubble Wet and Dry appliances

Bubble No 1 Cooking Stove plus boiler options.

Corner Cooking Stove plus boiler options.

Back Cabin Oil Fired Cooker.

FITTING OPTIONS.

There are normally two different situations that the installer may be faced with:-

1. A new build installation.

An established boat installation, (which has not had oil stove fitted).

2. A replacement installation, where there has been a solid fuel stove fitted previously.

Each of the situations will present differing problems which will be:-

- Where to locate the stove.
- How to deal with fireplace design.
- Where to locate the oil tank.
- How to get an oil supply to the stove.
- How to fit the chimney.
- How to connect water to the stove.
- How to disconnect and remove the stove, easily.

The new build situation should be the easiest.

The established boat situation will require careful attention to the sighting of the stove in relation to flue positions and existing fittings positions.

In replacement situations it may well be necessary to blank off the existing through roof flue position and cut a fresh one to suit the new location and comply with our instructions on flue design.

ABOUT THE APPLIANCES

Generally described as a space heater or space heater and cooker, which burns diesel oil in a controlled

manner utilizing a chimney to discharge the products of combustion.

The appliance generates heat from burning oil mixed with air in a vaporizing pot located in the bottom of the stove.

Once the appliance has been ignited, oil goes into the pot at a steady and controlled rate via a gravity feed which is metered by the OIL CONTROL VALVE; the oil flow can be controlled from minimum to maximum or any setting in between determined by the set position of the oil flow control knob.

Air is sucked into the pot by the natural action of the negative pressure in the chimney.

To allow the chimney to work correctly it is essential that you have adequate, unrestricted ventilation into the area where the stove is situated.

The amount of oil that can be successfully burned is directly proportional to the amount of air that the chimney can draw into the pot and so to achieve adequate combustion a balanced and appropriate flow of both oil and air is required.

The stove will provide space or combined space and water heating and in some cases cooking as well.

Where cooking and water heating are combined one feature will inevitably effect the other.

There are different versions of each appliance within the total range.

Some of the appliances are supplied as Dry, Small Boiler and Large Boiler versions namely B1 Half Pod, B1 Oven and B2.

Some of the appliances are supplied just as Dry and Large Boiler versions namely Corner Stove and Corner Oven Stove.

The Back Cabin Cooker can be supplied with or without a small boiler for domestic hot water heating only.(1kw)

All of the boilers are high water content and suitable for pumped or gravity systems and pressurised or open vented systems ASSUMING THAT THEY ARE INSTALLED BY SUITABLY QUALIFIED PERSONS.

All the appliances are fitted with a descaling device which should be rotated on a two weekly cycle to descale the oil inlet pipe.

Where applicable, appliances must not be operated with the glass front door opened or cracked, or without the lighting port plug fitted.

Where applicable, the door glass may require light cleaning occasionally depending upon the continuous running time of the stove.

Appliances must be securely bolted down to resist impact or collision and must be level in both directions.

All the appliances are supplied with clamp down brackets except the Back Cabin Cooker which must be fastened down through the foot plates.

The top of the appliances can be used for warming and cooking.

The oven appliances have a comprehensive range of cooking facilities with both oven and hot plate cooking available.

Some appliances can also be supplied with a coal kit, which just like a solid fuel stove, coal effect will only be available when the stove is running at maximum or near maximum performance.

Suitable deck flanges, flue systems and anti-downdraft cowls must be used.

CONTROLS

The output of the stove is regulated by the amount of oil allowed to go into it and this function is controlled by the -:

OIL CONTROL VALVE (O.C.V.), Turning the knob anti clockwise controls the oil flow.

2. SAFETY.

Take care to make sure that all safety and ventilation issues are adequately addressed.

FUMES

Always fit a suitable Smoke and Carbon Monoxide alarm within 1.5meters of the appliance.

Make sure that the function is checked on regular basis. (weekly)

Make sure that the alarm can be heard in the sleeping quarters.

Here are the main causes of fume or smoke to leak from the stove.

- The chimney is blocked.
- There are too many bends in the chimney.
- The above deck chimney extension is not high enough.
- The boat is moored in a position near to high buildings or trees and downdraughting is occurring.
- The chimney or parts of it are not airtight.

- There are unusually strong cross winds.

If down draughting occurs turn the appliance off until the winds subside and do not attempt to re-ignite the appliance until it has completely cooled down.

When it has cooled down, before attempting to ignite the appliance remove the catalyser and examine the base of the pot to make sure that there is no oil left in the pot, if there are signs of oil in the pot do not attempt to ignite the appliance until it has been completely dried out.

FIRE

Fire can be caused by a variety of potential danger points and because of the space limitation on boats; this risk is ever present and must be adequately assessed.

The main danger is the effects of heat from the stove on combustible materials and boat occupants.

Make sure that all combustibles are adequately protected from the effects of heat radiation.

Appliances must stand on a fireproof base of minimum thickness 30mm or a purpose made stand.

Floors in front of the stove must have suitable fire protection.

Built in stove heat shields should not be removed under any circumstances.

BURNS

During normal, day-to-day use, many parts of the stove, pipe work, and chimney will become too hot to touch.

Hot surfaces must be adequately protected to prevent anyone falling on to, or touching them.

Suitable fireguards for the appliance and chimney must be fitted.

Fireguards must comply with BS6539.

Always use heatproof gloves when working on or near to a hot stove.

CLEARANCES FROM COMBUSTIBLES

The appliances must be fitted in line with the distances specified in the tables.

All hearths and fireplaces must be made from non-combustible materials and adequately designed for the job.

CLEARANCES FROM COMBUSTIBLES-FLUE PIPES

Flue pipes must be fitted in line with the distances specified in the table and must be suitable for the individual application.

Any combustible materials within the specified distances from the appliances must be protected by a suitable heat shield.

Protection can be gained by the use of -:

- Sheet metal heat shields and spacers.
- Heat resistant boards such as TAC board.
Combustible materials can be-:
- Wooden furniture.
- Curtains.
- Wooden panels or frames adjacent to the flue pipe or where it passes through the deck of the boat.
- Carpet or flooring close to the stove.
- Items near to the stove, which could fall onto it and ignite, should the boat suffer a slight impact or collision.

VENTILATION.

Ventilation plays a vital role in the fitting and sighting of any stove.

The provision of ventilation for these appliances is adequately covered by the requirements of the boat safety scheme.

25cm sq. minimum permanent ventilation, directly to outside air, must be provided.

FLOODED VAPOURIZING BURNER POTS.

When attempting to light any of the appliances, make sure that the pot is not flooded with oil by looking into the base of the burner.

If it is flooded remove the excess oil.

Never try to relight a hot stove; wait until it has cooled down.

Hot oil vapour is explosive.

Never try to light a flooded pot.

SECURELY FIX THE APPLIANCE

The stove must be securely fastened down so that it can resist impact or collision and it must be level in both directions.

Level the stove in both directions when the vessel is midway between its maximum and minimum trim conditions.

Bubble appliances must not be fitted if the maximum angle of trim exceeds 0.75 deg forward to aft or port to starboard.

Only suitably qualified persons can install unvented plumbing systems.

A suitable and serviceable fire extinguisher should always be readily accessible.

3. CHIMNEY

This is the one of the most interesting problems the installer has to deal with and as the chimney affects most aspects of running the stove, we take time here to list the following information for your consideration.

The power, (*suck or vacuum the chimney can develop*) depends upon the following-:

THE HEIGHT.

THE DIAMETER.

THE TEMPERATURE OF THE GASSES IN IT.

THE RESISTANCE OF THE INNER SURFACE OF THE FLUE PIPE OR PIPES.

THE TYPE OF TERMINAL.

THE PREVAILING ATMOSPHERIC CONDITIONS.

It is obvious that on a boat all the above elements are in short supply.

Normally, we have low flues which are small in diameter and generally not very well insulated, coupled with all these problems we have another one, which is that the boat moves across constantly changing surroundings, through locks, into headwinds and crosswinds, all creating major opportunity for down draughting to occur.

Any bend in any part of the chimney or roughness on the internal chimney wall will slow down the velocity of rising gases and reduce the effectiveness of the chimney.

Any slight reduction in the flue gas temperature will reduce the chimney vacuum or pull, hence when the stove is slowed down for all night burning, as the flue gas cools down the chimney vacuum reduces and as the chimney vacuum drops, the stove may well start to burn sooty. This problem is highlighted even more during very cold weather when the chimney can cool down even faster. In these situations careful attention to servicing and low fire setting is essential.

THE CHIMNEY RULES.

1. Always use a top outlet for flue pipe take off.
2. Always try to get the stove as low as possible in the boat, this will allow installation of maximum length flue pipe.
3. Clean or have the chimney cleaned regularly. (Frequency depends upon type of fuel and length of time used).

4. FUEL SUPPLY.

There are several problems relating to diesel fuel supply, which need be adequately addressed.

WAXING

Cold weather waxing or thickening alters the flow characteristics of diesel.

An adequate fuel feed supply can turn into an inadequate one when the temperature starts to fall.

The worst scenario is fuel feed pipe 50-60 feet long in 8mm dia pipe.

The best-case scenario is a fuel pipe 4 feet long in 10mm dia with insulated lagging.

AIR LOCKS

Air lock in oil feed pipe work must be avoided.

The pipe work must slope down to the appliance and be clipped level at 500mm intervals to prevent sagging.

Any rises in the pipe work will cause air locks on commissioning and after future oil run out situations, if it is not possible to run the pipe work in a steady slope then where changes occur a vertical venting leg should be fitted.

TRIM

Bubble appliances must not be fitted if the maximum angle of trim exceeds 0.75 deg forward to aft or port to starboard.

Level the stove in both directions when the vessel is midway between its maximum and minimum trim conditions.

A minimum pressure head of 254mm (10") is required.

This head is measured from the base of the oil tank to the top of the oil control valve. In some cases this head can be affected by the ballast or trim of the boat.

Take great care to try out all the different ballast and trim possibilities to make sure that adequate oil feed is always available at the outlet end of the fuel pipe before it enters the oil control valve at the stove.

TANK

If the stove is fitted at the bow of the boat, a bow tank is recommended.

The tank should comply with the requirements of the boat safety scheme and have:-

- A conveniently sized filler
- A means of venting.
- A conveniently located, easily visible, contents gauge.
- An isolation valve
- An easily replaceable cartridge filter.
- A suitable and substantial water trap

Do not use glass filter bowls, they are not acceptable under the boat safety scheme.

Make sure that your fuel supplier supplies you with appropriate fuel for wintertime running.

OIL LINE

The oil feed line starts after the fuel filter and proceeds to the point of entry, which is where the oil line goes into the cab or saloon of the boat.

The diameter of the oil line is dependent upon the length of run. See 3-2 on waxing and make sure that you have suitably sized compression fittings available.

At this point it is necessary to fit a 60 DEG C, remote sensing fire valve, designed to shut off the oil supply, should a fire occur near to the stove.

If the bubble stove is fitted up to the first bulkhead it will be necessary to fit the isolation valve outside the cabin or saloon of the boat. 5. Make sure that you have purged the oil feed line of all air and there is a steady and constant flow of oil available at the inlet to the oil valve. Make sure that all or any oil isolation devices are turned to the on position. Remember that the oil valve needs a min head of 300mm for gravity feed. When feeding from rear tanks with appliances fitted forward always be aware of the forward - aft trim of the vessel.

Do not use syphonic oil feeds to Bubble Appliances, oil should be fed by gravity or pumped via an appropriate pressure pump = head pressure less than 99mbar.

WATER CONTAMINATION

Because of the high risk of fuel contamination with water, we strongly recommend the fitting of a **high volume water trap**, in the oil supply line.

REMOTE SENSING FIREVALVES

There are two situations where a remote sensing firevalve should be fitted.

1. For fire protection fit a 60 deg C valve.
2. For over boil protection fit an additional 90 deg C valve.

For fire protection a remote sensing fire valve should be fitted as detailed in fig 3.

Run the capillary tube with the oil line up to the stove and carefully fit the sensing phial as follows

B1 Half Pod, B1 Oven and B2 at a low level fitted on two 15mm pipe clips.

Corner Stove and Corner Oven Stove on 15mm pipe clips in front of the drip tray on the fireplace hearth, directly in front of the combustion air restrictor.

Before it is fitted try the fender on the stove to make sure that the fender does not foul the sensing phial.

The sensing phial may be visible through the bottom of the fender, to mask it, paint it with matt black paint available from our sales desk.

When fitting the fire valve make sure that where the capillary and oil line go through the bulkhead in separate sleeved tubes, so that the capillary can be withdrawn separately should it ever need replacing.

For fitting of long oil feed lines which pass through bulkheads and various other parts of the boat it may well be necessary to fit more than one fire valve, especially where the oil line passes through an area where a fire could occur i.e. kitchen area etc.

ISOLATION VALVES.

Two isolation valves are required, one fitted directly into or close to the oil control valve to allow you or the service man to turn the oil off should the need arise, and one fitted directly into the oil tank before the fuel filter.

Always turn off the oil isolation valve serving the appliance before leaving the vessel unattended.

SLEEVING.

Where the oil line goes through the boat superstructure a suitable bulkhead fitting must be used.

OVERBOIL OR OVERHEAT PROTECTION OF THE APPLIANCE.

Where appliances are not fitted with an automatic thermostat an additional 90 DEG C, remote sensing

fire valve must be fitted directly in front of the oil control valve and the sensor from this valve has to be attached to the water jacket or the hot outlet pipe from the boiler.

The valve is calibrated to shut the oil supply down should the water temperature exceed 90 Deg C.

There is a re set button on the remote sensing fire valve which needs to be pressed in to re set the valve after it has tripped off.

4A LIGHTING & COMMISSIONING

A relevant oil control valve catalogue is supplied with each appliance and details of high and low fire adjusting screws are illustrated.

On the Toby valve the low fire screw is clearly visible as per TOBY MANUAL FIG 2

Before trying to light the burner in cold weather it is advisable to pre heat the flue pipe before lighting.

There are two different types of burner fitted to Bubble appliances.

The FB style burner fitted to the **B1 Half Pod, B1 Pie Pod and B2.**

The Socomef burner fitted to the **Corner Stove, Corner Oven Stove** and the **Back Cabin Cooker see sec 4B for lighting Socomef burners.**

1. LIGHTING B1 HALF POD, B1 PIE POD AND B2

When attempting to light the stove these are the rules, which must be followed.

1. Always make sure that the pot is **not** flooded with oil by looking down into the base of the pot.
2. Never try to light the stove if it is flooded with oil.
3. Always check that oil has not leaked from the appliance.
4. Do not light the stove and leave it unattended until it is settled down and stabilized into constant blue flame combustion on low fire. (This could take 10 to 20 minutes.)

On first light up it is advisable to warm the flue pipe up to try and create chimney draft.

Two Ways to Light the Stove

1. Through the lighting port B1 and B2 appliances only,
or
2. Directly into the base of the pot by removing the catalyser.

Lighting into the base of the Pot

On the first light up you may find this option better, as it is possible to see the oil trickle in to the pot more easily.

Use a heatproof glove when putting the catalysers back into the pot and it is important to replace them quickly whilst the flame is small.

Make sure that the oil is turned off.

Open the front door.

Remove the optional coal kit if fitted.

Remove the catalyser.

Turn the oil on and allow a small pool of oil to flow into the pot about the size of a small biscuit, **then turn the oil off.**

Note that on first light up it may take a few minutes for the oil to reach the pot as it has to fill the pipework before reaching the pot, take care not to allow excess oil to flow into the pot.

Light a small piece of firelighter and drop it into the oil, allow a few seconds for it to get going and then replace the catalyser and coal kit if fitted, and close the door.

Wait for approx. 1 minute until the pool of oil is alight and then **turn the oil on** to minimum setting no 1.

Watch the appliance for a few minutes and you will see the flame establish and settle down into blue flame combustion.

Allow the burner to run for a further 10 minutes before turning the appliance up to the higher settings.

If at any time during the ignition process large amounts of flame can be seen, turn the oil off immediately and wait until the flames die down before putting the oil on again at minimum setting.

Manual Lighting through the Lighting Port B1 and B2 appliances.

Check that the isolation valve is turned on.

Open the front door.

Remove the front apron on B1 Half Pod and B1 pie Pod.

Remove the lighting port plug by pulling it out of its tubular socket.

Turn the oil on to the first position via the flow control knob and allow a small pool of oil to flow into the pot about the size of a small biscuit.

Turn the oil off.

Cut a small piece of firelighter and stab it onto the spike.

Light it and push it into the lighting port tube, let the firelighter drop off the spike into the bottom of the pot.

Replace the lighting port plug back into the tube.

Close the front door.

Turn the fuel flow on again at the lowest setting

Watch the appliance for a few minutes until it settles down into blue flame combustion.

Allow the burner to run for a further 10 minutes before turning the appliance up to the higher settings.

If at any time during the ignition process large amounts of flame can be seen, turn the oil off immediately and wait until they die down before putting the oil on again.

Note there may be the occasional growl or audible vibration whilst the burner settles down into blue flame combustion.

COMMISSIONING THE HIGH & LOW FIRE, CHRYSTAL SERIES

Used in B1 Half Pod, B1 Pie Pod and B2

When the burner has established good blue flame combustion turn it up to half output. (Setting 3 on the fuel flow control knob) and let it stabilize.

Allow at least half an hour for the chimney to warm up thoroughly before making any adjustments to the high or low fire screws.

Turn the stove down onto minimum firing rate and let it stabilize.

After stabilization there should be a dull red glow in the lower catalyser with wispy blue flames flicking into and just over it.

If the flame falls into a dirty rolling yellow flame and the catalyser is not dull red then the low fire will need to be increased until it can support the required blue flame combustion.

To increase the low fire oil flow, screw the adjusting screw out by quarter turn increments.

When you are happy with the low fire, set the high fire.

Turn the oil flow knob up to setting 4, let the flame stabilize, and look at it, if it is stable and blue, turn it up slowly using the control knob, letting it stabilize after each movement, if the flame starts to go yellow with long flame combustion, it is running fuel rich and

the high fire screw needs adjusting to reduce the flow of oil. (Screw the adjuster screw in to reduce the high fire oil flow.)

Before adjusting the high fire screw, turn the flame down and let it stabilize in blue flame combustion, adjust the high fire screw by half a turn in and try turning the fuel flow up, if it is still fuel rich repeat the process until the high fire flame is running blue with just flicks of yellow in the tips.

To see a bubble stove running correctly see the following link

<https://www.youtube.com/watch?v=UqdQLFp3HkQ>

4B LIGHTING & COMMISSIONING THE BURNER SOCOMEF SERIES

1. LIGHTING CORNER STOVE, CORNER POD AND BACK CABIN COOKER.

When attempting to light the stove these are the rules, which must be followed.

1. Always make sure that the pot is not flooded with oil by looking down into the base of the pot.
2. Never try to light the stove if it is flooded with oil.
3. Always check that oil has not leaked from the appliance.
4. Do not light the stove and leave it unattended until it is settled down and stabilized into constant blue flame combustion on low fire. (This could take 10 to 20 minutes.)
5. Make sure that you have purged the oil feed line of all air and there is a steady and constant flow of oil available at the inlet to the oil valve. Make sure that all or any oil isolation devices are turned to the on position. Remember that the oil valve needs a min head of 300mm for gravity feed. When feeding from rear tanks with appliances fitted forward always be aware of the forward - aft trim of the vessel.
6. Do not use syphonic oil feeds to Bubble Appliances, oil should be fed by gravity or pumped via an appropriate pressure pump = head pressure less than 99mbar.

On first light up it is advisable to warm the flue pipe up to try and create chimney draft.

Lighting the Stove

Lighting the stove takes a little time and patience; the following procedure should be adopted.

In the case of the Corner appliances, open the front door and in the case of the Back Cabin Cooker remove the hot plate and top baffle to gain access to the

burner, note that the back cabin cooker has a lighting port fitted behind the lower ash pit door.

Remove the coal kit if it has been supplied with the stove.

Lift the inner mesh catalyser from the burner.



Look into the bottom of the pot and turn the oil on at full rate, allow oil to flow into the bottom of the pot to form a pool about the size of a small digestive biscuit and then turn the oil off.

Note that on first light up it may take a few minutes for the oil to reach the pot as it has to fill the pipework before reaching the pot.

Do not allow any depth of oil to build up.

Light a small piece of firelighter (about the size of a pineapple chunk) and place it into the centre of the oil pool.

Replace the mesh catalyser and the coal kit, if fitted and then leave the door slightly open whilst the firelighter gets the oil going.

After 30 to 40 seconds, you will notice the flame start to establish itself and spread around the bottom of the pot.

When this occurs, close the door or replace the baffle and top plate and then turn the oil on to its minimum setting.

After two or three minutes the flame should slowly change from yellow into blue flame combustion and settle down to a steady burn.

Note there may be the occasional growl or audible vibration whilst the burner settles down into blue flame combustion.

Allow the burner 10 - 15 minutes to stabilise and the increase the flow of oil as required, moving by one increment of the dial only.

Do not leave the appliance unattended during the lighting and stabilising procedure.

COMMISSIONING THE HIGH AND LOW FIRE SOCOMEF BURNERS.

Corner Stove, Corner Pod and Back Cabin Cooker.

Note that Back cabin Cookers are pre commissioned at the factory and do not need adjusting.

A relevant oil control valve catalogue is supplied with each appliance and details of high and low fire adjusting screws are illustrated.

On the Toby valve the low fire screw is clearly visible as per TOBY MANUAL FIG 2

When the burner has established good blue flame combustion turn it up to half output. (Setting 3 on the fuel flow control knob) and let it stabilize for a minute. Allow at least half an hour for the chimney to warm up thoroughly before making any adjustments to the high or low fire screws.

Turn the stove down onto minimum firing rate and again let it stabilize.

After stabilization there should be a dull red glow in the catalyser with wispy blue flames flickering just over the top of it, approximately level with the top of the pot.

If the flame falls into a dirty rolling yellow flame and the catalyser is not dull red then the low fire will need to be increased until the burner can support the required blue flame combustion.

When you are happy with the low fire, set the high fire.

Turn the oil flow knob up to setting 4, let the flame stabilize, and look at it, if it is stable and blue, turn it up slowly using the control knob, letting it stabilize after each movement, if the flame starts to go yellow with long flame combustion, it is running fuel rich and the high fire screw needs adjusting to reduce the flow of oil. (Screw the adjuster screw in to reduce the high fire oil flow.)

Before adjusting the high fire screw, turn the flame down and let it stabilize in blue flame combustion, adjust the high fire screw by half a turn in and try turning the fuel flow up, if it is still fuel rich repeat the process until the high fire flame is running blue with flicks of yellow in the tips.

On the Socomef pot, the high fire flame will be set approx. 40mm above the top of the pot.

NOTE THAT THIS PROCEDURE WILL NOT BE POSSIBLE IF THE CHIMNEY RULES HAVE NOT BEEN ADHERED TO.

THE HIGH FIRE SETTING WILL HAVE TO BE ADJUSTED IN LINE WITH THE AVAILABLE GENERATED CHIMNEY VACUUM IE

THE FLUE PIPE MUST BE A MINIMUM OF 1.8 METERS HIGH FOR LOW FIRE AND 2.1 METERS FOR HIGH FIRE.

INSTALLING ENGINEERS SHOULD NOT LEAVE THE APPLIANCE UNDER THE CONTROL OF THE CUSTOMER UNLESS THE APPLIANCE HAS BEEN CORRECTLY COMMISSIONED.

TO SEE HOW THE BURNER SHOULD OPERATE COMMISSIONING AND INSTALLING ENGINEERS SHOULD VISIT

<https://www.youtube.com/watch?v=UqdQLFp3HkQ>

This video shows a stove running from low to high fire and back to low fire. Note that this video is filmed on a normal house chimney and so it may not be possible to get exactly the same conditions on a typical boat flue as the fuel air ratio will not be exactly the same, hence the need for fine tuning the oil flow to the chimney air flow capability.

5. FIREPLACE.

Unless one is built into the appliance, always fit appliances on a suitable drip tray.

The possibility of oil drops leaking from the stove must be considered; a suitable oil drip tray must be fitted and designed in such a way, as it will contain any oil leaks or drips.

Normally the tray will cover the footprint of the stove, the oil valve and isolation device.

It will be oil tight and have a vertical up stand of at least 30mm. This should give a minimum containment volume of 2 litres.

It will be securely fastened down to the vessel and the appliance must be securely fastened down to the oil drip tray.

Make sure that drip trays are tested to ensure that they do not leak when filled with oil.

The hearth must be:-

FLAT - SECURE - FIREPROOF AND LEVEL IN BOTH DIRECTIONS.

Use materials, which are easy to keep clean and fireproof such as tiles, asbestolux or vermiculite boarding with a suitable weight resistant liner.

The vertical walls of the fireplace must also be made from fireproof materials.

Use fireproof, rockwool infill behind the fireplace panels to protect any combustible insulation materials

such as spray foam.

6. DISTANCES FROM COMBUSTIBLES (APPLIANCES)

Stove Type	ABOVE	SIDES.	BACK	FRONT	HEARTH Non Combustible Material
B1 HALF POD and OVEN VERSION	500	300	150 FROM HEAT SHIELD	300 to allow door opening.	30MM THICK x 100 projection at the front and sides
BOAT B2	600	300	150 FROM HEAT SHIELD	300 to allow door opening.	30MM THICK x 100 projection at the front and sides
CORNER and OVEN VERSION	500	75	100 FROM HEAT SHIELD	300 to allow door opening.	30MM THICK x 100 projection at the front.
BACK CABIN COOKER	500	150	100 FROM HEAT SHIELD	300 to allow door opening.	25MM THICK x 150 projection at sides

7. DISTANCES FROM NON COMBUSTIBLES (APPLIANCES)

Stove Type	ABOVE	SIDES.	BACK	FRONT	HEARTH Non Combustible Material
B1 HALF POD and OVEN VERSION	300	150	150 FROM HEAT SHIELD	300 to allow door opening.	30MM THICK x 100 projection at the front and sides.
BOAT B2	300	150	150 FROM HEAT SHIELD	300 to allow door opening.	30MM THICK x 100 projection at the front and sides.
CORNER and OVEN VERSION	200	150	25 FROM HEAT SHIELD	300 to allow door opening.	30MM THICK x 100 projection at the front and sides.
BACK CABIN COOKER	500	75	50 FROM HEAT SHIELD	300 to allow door opening.	25MM THICK x 75 projection at sides

Note that the back cabin cooker can have the oil control valve fitted to the rear or the left hand side in each case the positioning of the valve will affect the fireplace and spacing considerations, see sizes of cooker to establish requirements.

8. DISTANCES FROM COMBUSTIBLES (FLUE PIPES)

For all appliances-:

1. Single skin flue pipes. Horizontal Distance = 50mm **when fitted within the deck flange** at the top of the chimney system, protected by the fire stop spacer.
2. Single skin flue pipes. Horizontal Distance = 150mm **when exposed in the saloon or living space.**
3. Twin Wall Insulated flue pipes. Horizontal Distance = 30 mm for insulated flue pipe systems.

9. ILLUSTRATIONS

FIG 1. STOVE DISTANCE FROM COMBUSTIBLES

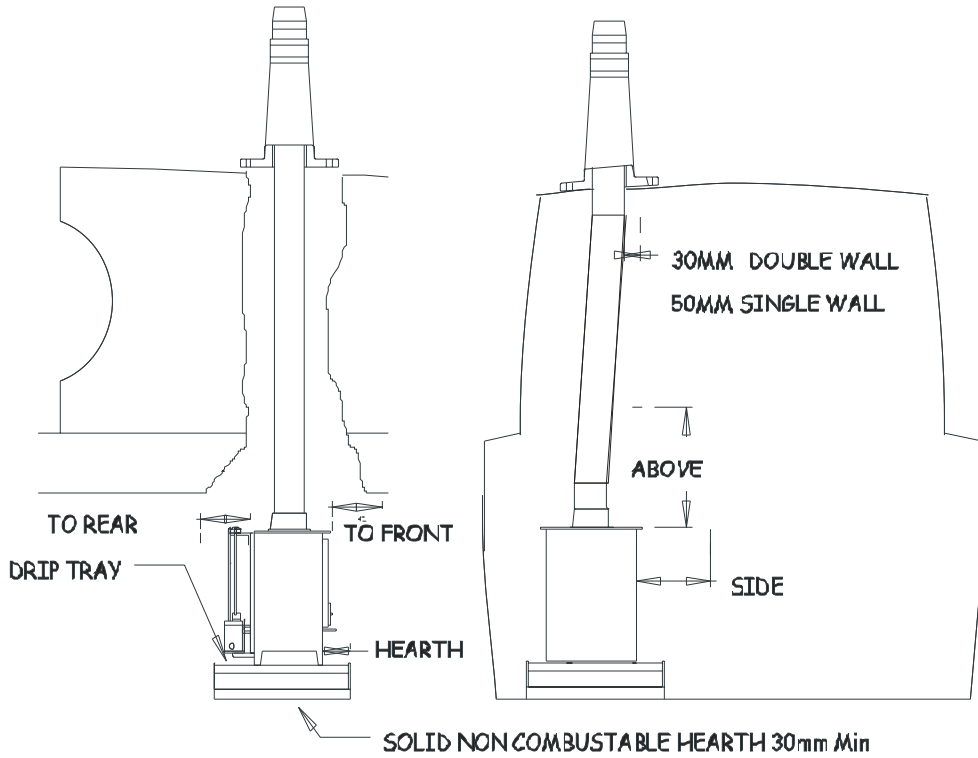

FIG 2 BUBBLE MK1 FABRICATED DECK FLANGE LAYOUT

Note that there is mk3 system which is now available and detailed on our web site.

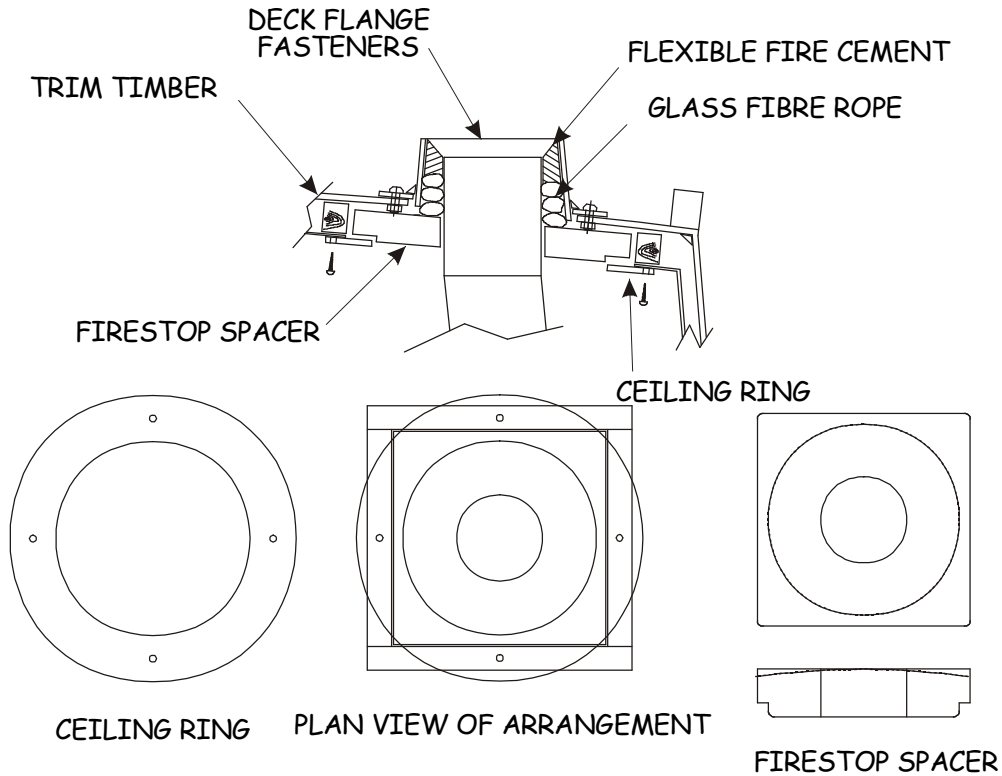
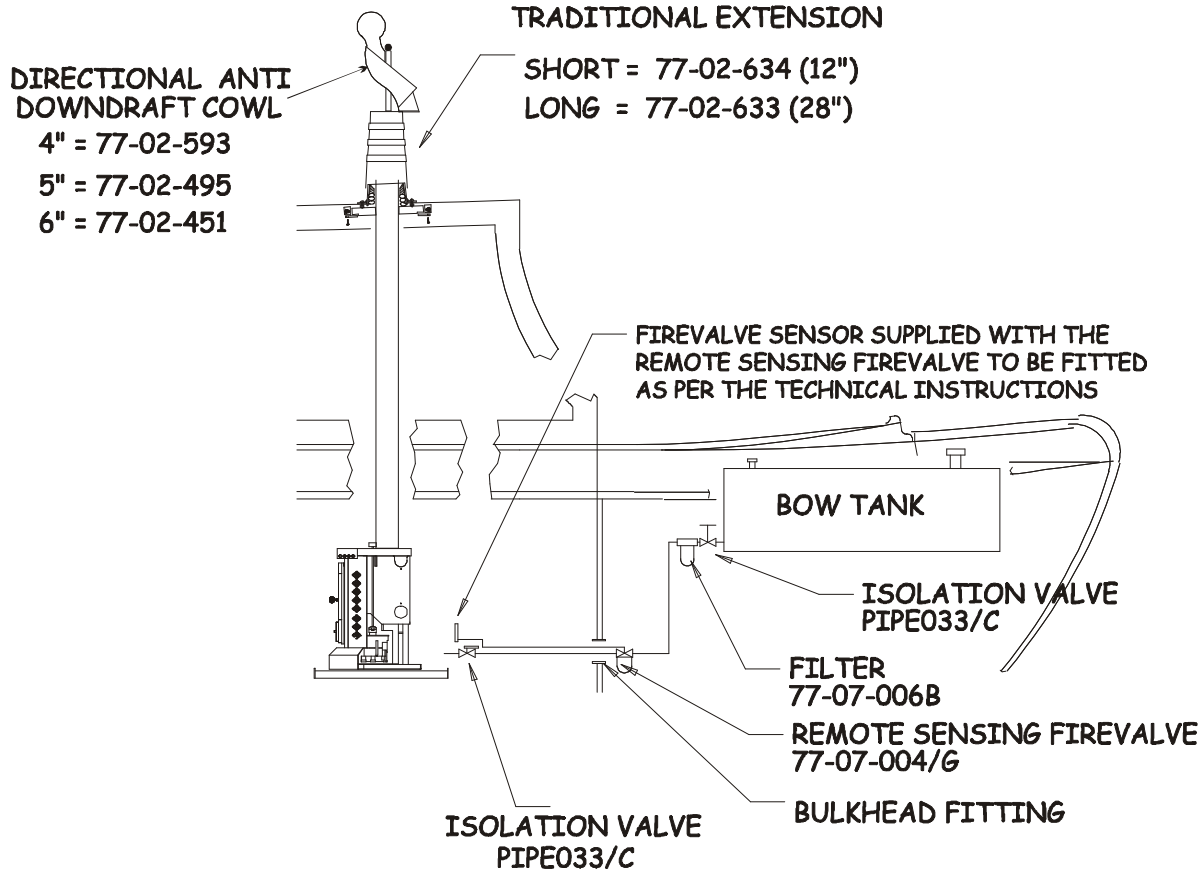

FIG 3 TYPICAL OIL FEED LAYOUT



COPYRIGHT HARWORTH HEATING LTD 080800

FIG 4 TYPICAL PUMING LAYOUTS

Drq 1

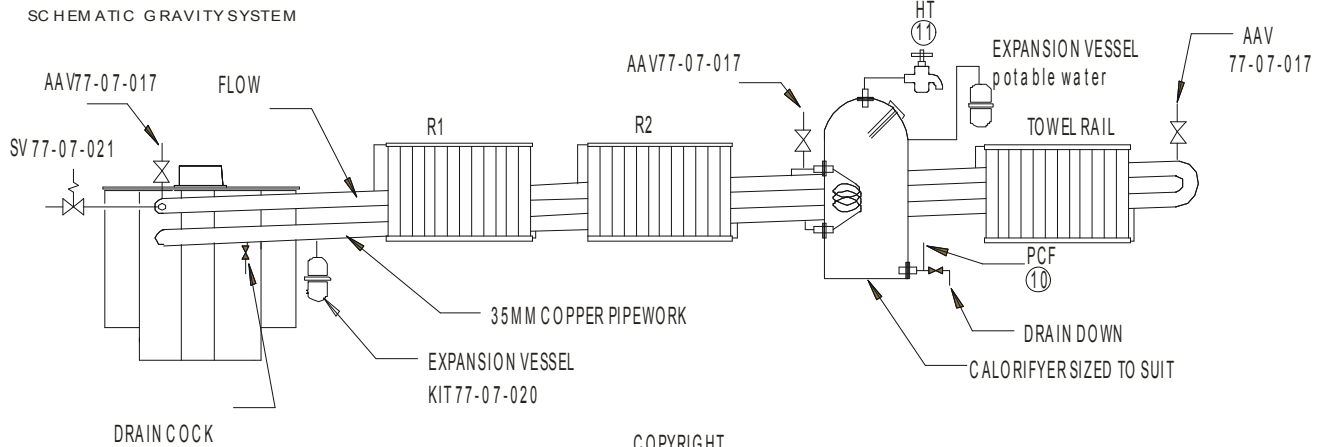

COPYRIGHT BUBBLE PRODUCTS 2013

Drg 2

SCHEMATIC PUMPED SYSTEM ISS 2 OF 28-10-17

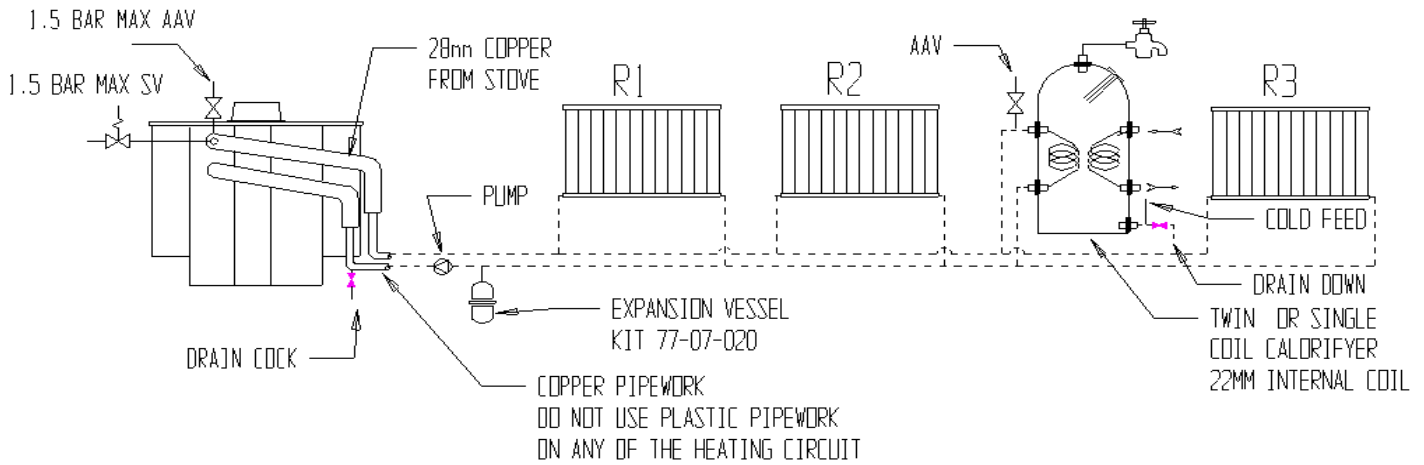

Drg 3

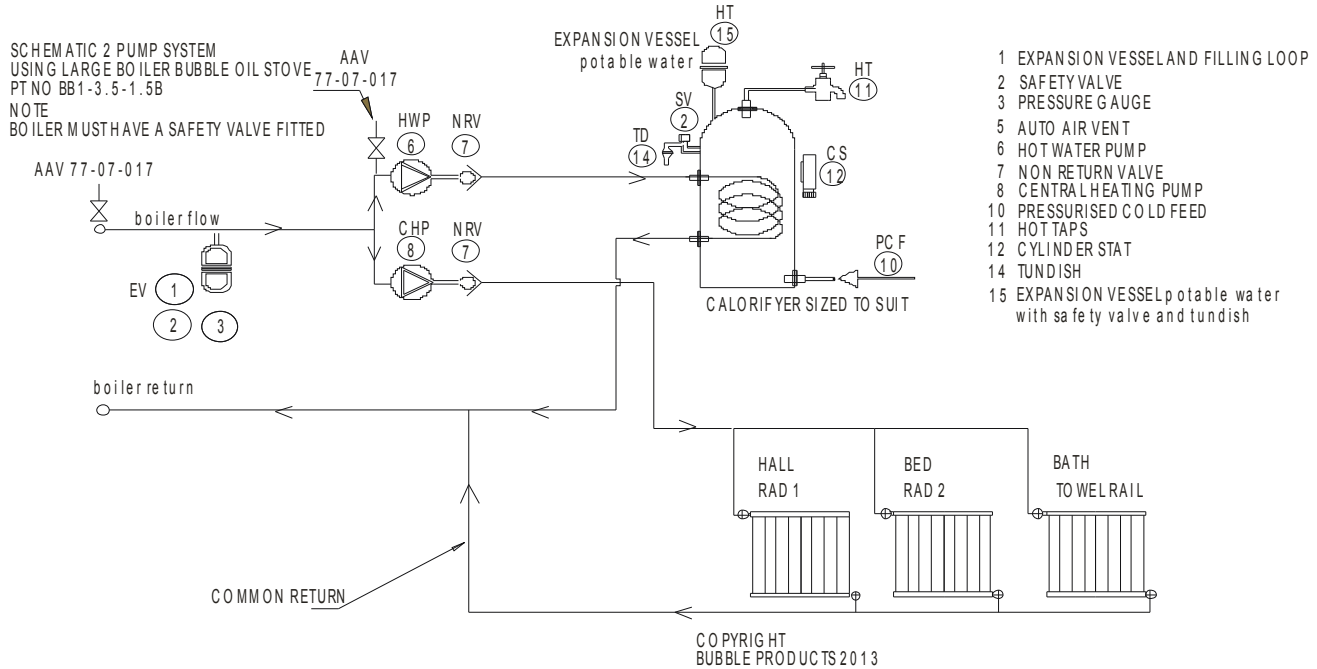

10. STOVE DIMENSIONS

10-1 BB1 HALF POD AND PIE POD DIMENSIONS

Note that the B1 Pie Pod has the same footprint dimensions but the vertical height is 830mm.

**B1 HALF OIL POD OF 12-02-15
OVERALL DIMENSIONS
BOILER AND NON BOILER VERSIONS**

**.WEIGHT 35.KG NON BOILER
WEIGHT 45.KG SMALL BOILER
.WEIGHT 50.KG LARGE BOILER**

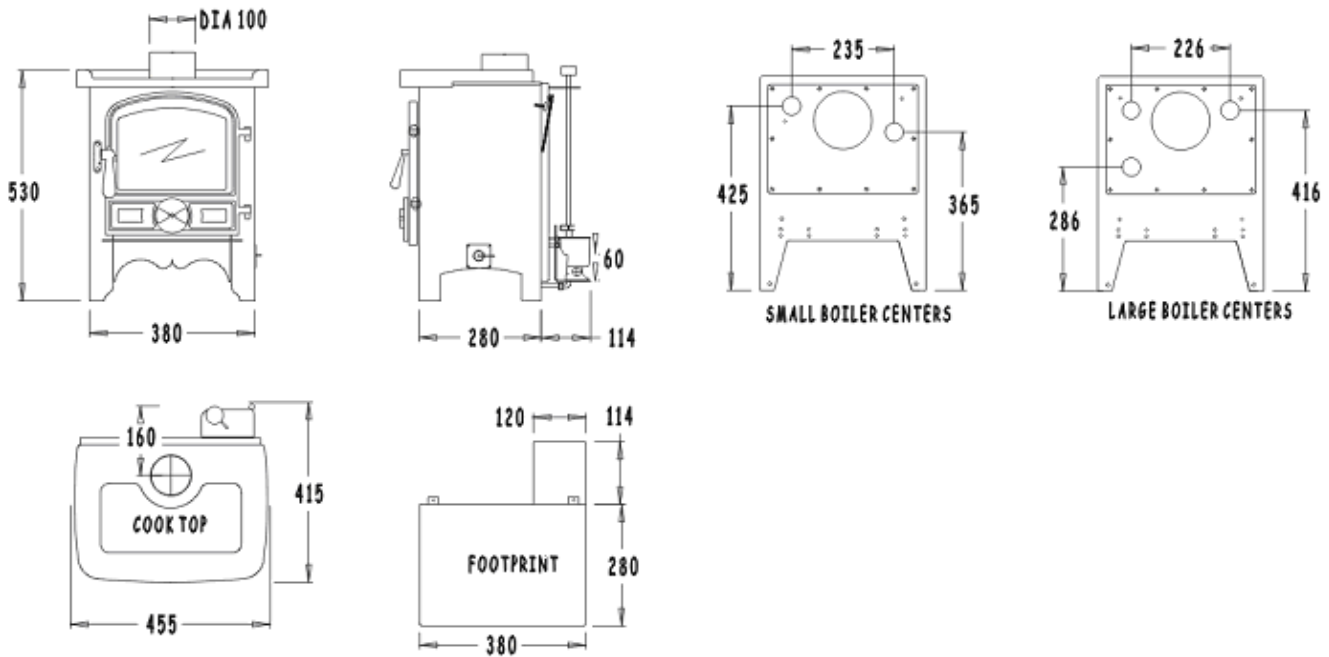

10-2 CORNER STOVE AND CORNER PIE POD DIMENSIONS

Note that the Corner Pie Pod has the same footprint dimensions but the vertical height is 840mm.

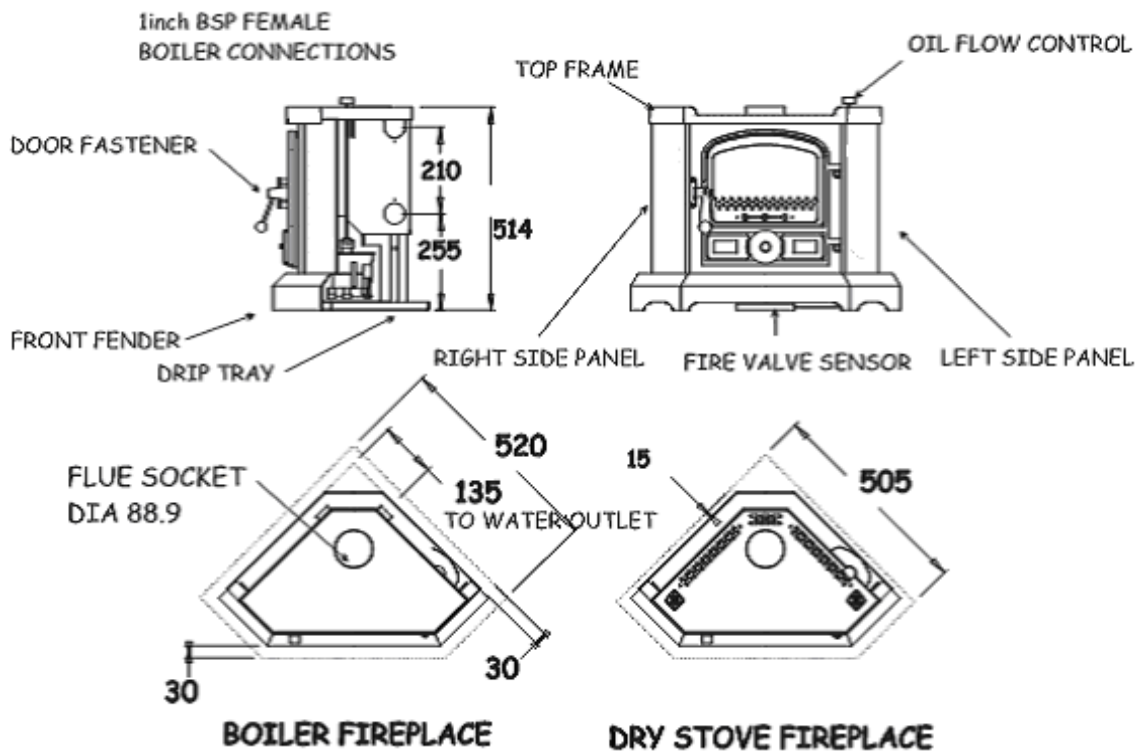

10-3 B2 STOVE DIMENSIONS

Note that the B2 Pie Pod has the same footprint dimensions but the vertical height is 830mm.

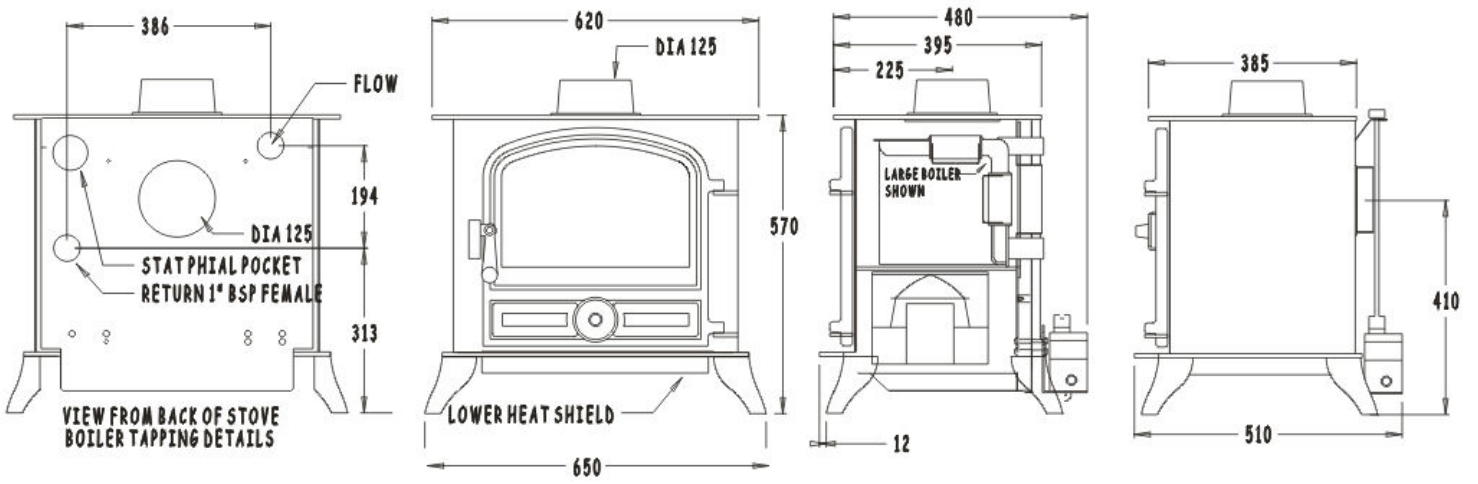

10-4 BACK CABIN COOKER DIMENSIONS

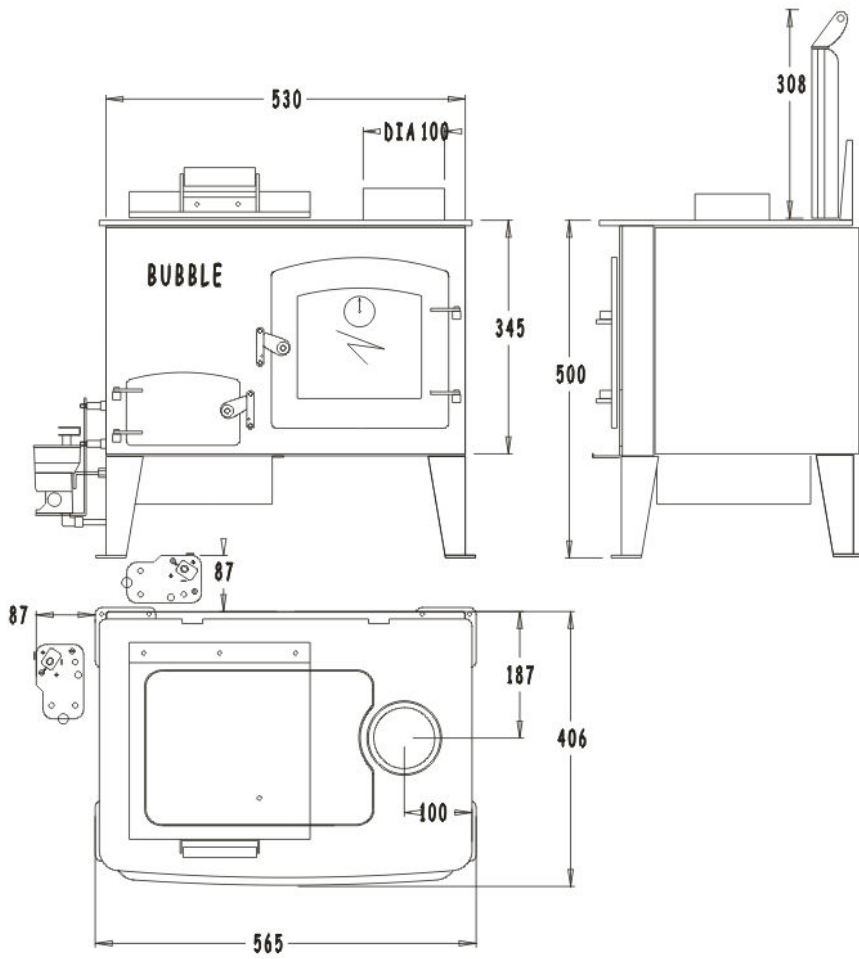

11. OIL CONSUMPTION RATES

		MAX HEAT OUTPUT TO WATER	MAX HEAT OUTPUT TO SPACE	MINIMUM OIL FLOW CC'S PER MIN	MAXIMUM OIL FLOW CC'S PER MINUTE
--	--	--------------------------	--------------------------	-------------------------------	----------------------------------

B1 HALF POD & OVEN DERIVATIVE

Free Standing	From 1.6kW to 5kW		5kW	4 = (1.6kW)	12 = (5kW)
Free Standing	From 1.6kW to 5kW	2kW	3kW	4 = (1.6kW)	12 = (5kW)
Free Standing	From 1.6kW to 6kW	5kW	2kW	4 = (1.6kW)	13 = (6kW)

CORNER STOVE & OVEN DERIVATIVE

Free Standing	From 1kW to 4kW		4kW	3 = (1kW)	10 = (4kW)
Free Standing	From 1kW to 4kW	3kW	1kW	3 = (1kW)	10 = (4kW)

BUBBLE 2

Free Standing	From 1.6kW to 5kW		5kW	4 = (1.6kW)	13 = (5kW)
Free Standing	From 1.6kW to 8kW		8kW	4 = (1.6kW)	16 = (8kW)
Free Standing	From 1.6kW to 8kW	3kW	5kW	4 = (1.6kW)	16 = (8kW)
Free Standing	From 1.6kW to 8kW	9kW	2kW	4 = (1.6kW)	22 = (11kW)

BACK CABIN COOKER

Free Standing	From 1.6kW to 5kW		3kW	4 = (1.6kW)	7 = (3kW)
Free Standing	From 1.6kW to 5kW	1kW	2kW	4 = (1.6kW)	7 = (3kW)

© HARWORTH HEATING LTD 30.6.98

This publication may not be copied by any means, without written permission from the authors.

These products are subject to continuous development and improvement and it is consequently acknowledged that due to this process there may be some omissions and errors.

This publication is intended only to assist the reader in the use of this product and therefore Harworth Heating Ltd shall not be liable for any loss or damage whatsoever arising from the use of any information, error or omission found in this publication.

The appliances mentioned in this publication can only be installed and serviced by approved personnel.

Approved personnel means that they must HAVE BEEN SUITABLY TRAINED, if there are any

reliability issues reported back to **Harworth Heating** or **Bubble Products**, the installing engineer will be responsible for carrying out any rectification work.

For details of suitable training courses contact: - www.oftec.org

12. NORMATIVE REFERENCES

Boat installation work comes under the control of: -
The Boat Safety Scheme.

This scheme provides statutory requirements and associated EN / BS Standards for most aspects of installation work on boats.

Further information and a copy of the requirements can be obtained from:-

www.boatsafetyscheme.com

Where guidance for oil fired appliances is not readily available from the Boat safety Scheme publication, we then point out a list of standards which pertain to domestic installations and which are generally covered by the latest version of the English Building Regulations Doc J.

When read in conjunction with:-

1. Our installation instructions.
2. The Boat Safety Scheme rules.
3. The other standards detailed, enough information should be provided to allow for a safe installation.

BS 5440	Flues.
BS 6999	Flues
BS 7840	Fuel Hoses.
BS EN1057	Copper Tubes.
BS1344 Part 3 1988 ISO8290 1987	Flues.
BS EN 1443:2003	Chimneys - General requirements.
BS EN1856 part 1 replacing BS 4543	Flues.
BS EN1856 part 2 & BS 715 1993	Flues.
BS 1945: 1971	Stove door
BS EN 10296-1	Steel tubes
BS ISO 10088:2001	
BS EN ISO 9094-2003	
BS EN 10297-1	Steel tubes
BS EN 13384-1	Chimneys
BS EN 10088-1:2005	Stainless steels - Part 1: List of stainless steels

INSTALLATION & GENERAL INSTRUCTIONS



Silent Simplicity just for you!

MARINE OIL STOVES ©

ISSUE 15 @ 22-06-18

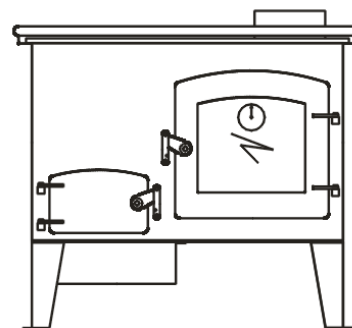
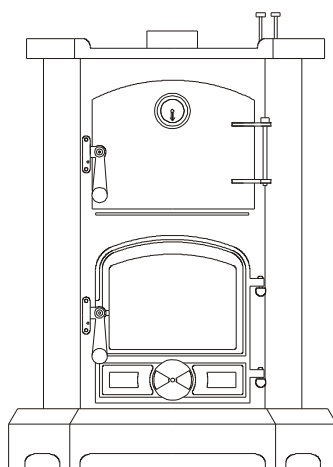
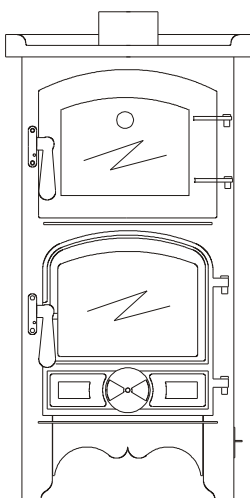
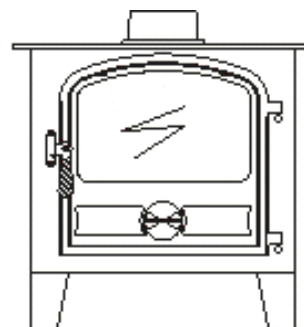
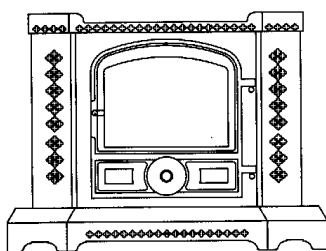
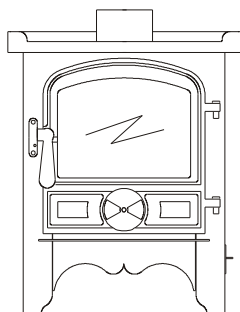

www.harworthheating.co.uk

INDEX

1. BEFORE STARTING THE JOB.	3
FITTING OPTIONS.	3
ABOUT THE APPLIANCES	3
2. SAFETY.	4
FUMES	4
FIRE	4
BURNS	4
CLEARANCES FROM COMBUSTIBLES	4
CLEARANCES FROM COMBUSTIBLES-FLUE PIPES	5
VENTILATION.	5
FLOODED VAPOURIZING BURNER POTS.	5
SECURELY FIX THE APPLIANCE	5
3. CHIMNEY	5
THE HEIGHT.	5
THE DIAMETER.	5
THE TEMPERATURE OF THE GASSES IN IT.	5
THE RESISTANCE OF THE INNER SURFACE OF THE FLUE PIPE OR PIPES.	5
THE TYPE OF TERMINAL.	5
THE PREVAILING ATMOSPHERIC CONDITIONS.	5
THE CHIMNEY RULES.	6
4. FUEL SUPPLY.	6
WAXING	6
AIR LOCKS	6
TRIM	6
TANK	6
OIL LINE	6
WATER CONTAMINATION	6
REMOTE SENSING FIREVALVES	7
ISOLATION VALVES.	7
SLEEVING.	7
OVERBOIL OR OVERHEAT PROTECTION OF THE APPLIANCE.	7
4A LIGHTING & COMMISSIONING	7
1. LIGHTING B1 HALF POD, B1 PIE POD AND B2	7
COMMISSIONING THE HIGH & LOW FIRE, CHRYSTAL SERIES	8
4B LIGHTING & COMMISSIONING THE BURNER SOCOMEF SERIES	9
1. LIGHTING CORNER STOVE, CORNER POD AND BACK CABIN COOKER.	9
COMMISSIONING THE HIGH AND LOW FIRE SOCOMEF BURNERS.	10
5. FIREPLACE.	10
6. DISTANCES FROM COMBUSTIBLES (APPLIANCES)	11
7. DISTANCES FROM NON COMBUSTIBLES (APPLIANCES)	11
8. DISTANCES FROM COMBUSTIBLES (FLUE PIPES)	11
9. ILLUSTRATIONS	12
FIG 1. STOVE DISTANCE FROM COMBUSTIBLES	12
FIG 2 BUBBLE MK1 FABRICATED DECK FLANGE LAYOUT	12
FIG 3 TYPICAL OIL FEED LAYOUT	13
FIG 4 TYPICAL PUMBING LAYOUTS	13
10. STOVE DIMENSIONS	14
10-1 BB1 HALF POD AND PIE POD DIMENSIONS	14
10-2 CORNER STOVE AND CORNER PIE POD DIMENSIONS	15
10-3 B2 STOVE DIMENSIONS	15
10-4 BACK CABIN COOKER DIMENSIONS	16
12. NORMATIVE REFERENCES	18

If you have any difficulties please phone our technical help line on-:

01302 742520 fax 01302 750573

e-mail contact@bubbleproducts.co.uk

<http://www.bubbleproducts.co.uk>

1. BEFORE STARTING THE JOB.

THE FOLLOWING NOTES PROVIDE INFORMATION FOR INSTALLATION OF THE FOLLOWING APPLIANCES.

Boat Bubble No 1 AND HALF POD, Dry Small and Large Boiler Appliances

Boat Bubble No 2 Dry Small and Large Boiler Appliances

Marine Corner Bubble Wet and Dry appliances

Bubble No 1 Cooking Stove plus boiler options.

Corner Cooking Stove plus boiler options.

Back Cabin Oil Fired Cooker.

FITTING OPTIONS.

There are normally two different situations that the installer may be faced with:-

1. A new build installation.

An established boat installation, (which has not had oil stove fitted).

2. A replacement installation, where there has been a solid fuel stove fitted previously.

Each of the situations will present differing problems which will be:-

- Where to locate the stove.
- How to deal with fireplace design.
- Where to locate the oil tank.
- How to get an oil supply to the stove.
- How to fit the chimney.
- How to connect water to the stove.
- How to disconnect and remove the stove, easily.

The new build situation should be the easiest.

The established boat situation will require careful attention to the sighting of the stove in relation to flue positions and existing fittings positions.

In replacement situations it may well be necessary to blank off the existing through roof flue position and cut a fresh one to suit the new location and comply with our instructions on flue design.

ABOUT THE APPLIANCES

Generally described as a space heater or space heater and cooker, which burns diesel oil in a controlled

manner utilizing a chimney to discharge the products of combustion.

The appliance generates heat from burning oil mixed with air in a vaporizing pot located in the bottom of the stove.

Once the appliance has been ignited, oil goes into the pot at a steady and controlled rate via a gravity feed which is metered by the OIL CONTROL VALVE; the oil flow can be controlled from minimum to maximum or any setting in between determined by the set position of the oil flow control knob.

Air is sucked into the pot by the natural action of the negative pressure in the chimney.

To allow the chimney to work correctly it is essential that you have adequate, unrestricted ventilation into the area where the stove is situated.

The amount of oil that can be successfully burned is directly proportional to the amount of air that the chimney can draw into the pot and so to achieve adequate combustion a balanced and appropriate flow of both oil and air is required.

The stove will provide space or combined space and water heating and in some cases cooking as well.

Where cooking and water heating are combined one feature will inevitably effect the other.

There are different versions of each appliance within the total range.

Some of the appliances are supplied as Dry, Small Boiler and Large Boiler versions namely B1 Half Pod, B1 Oven and B2.

Some of the appliances are supplied just as Dry and Large Boiler versions namely Corner Stove and Corner Oven Stove.

The Back Cabin Cooker can be supplied with or without a small boiler for domestic hot water heating only.(1kw)

All of the boilers are high water content and suitable for pumped or gravity systems and pressurised or open vented systems ASSUMING THAT THEY ARE INSTALLED BY SUITABLY QUALIFIED PERSONS.

All the appliances are fitted with a descaling device which should be rotated on a two weekly cycle to descale the oil inlet pipe.

Where applicable, appliances must not be operated with the glass front door opened or cracked, or without the lighting port plug fitted.

Where applicable, the door glass may require light cleaning occasionally depending upon the continuous running time of the stove.

Appliances must be securely bolted down to resist impact or collision and must be level in both directions.

All the appliances are supplied with clamp down brackets except the Back Cabin Cooker which must be fastened down through the foot plates.

The top of the appliances can be used for warming and cooking.

The oven appliances have a comprehensive range of cooking facilities with both oven and hot plate cooking available.

Some appliances can also be supplied with a coal kit, which just like a solid fuel stove, coal effect will only be available when the stove is running at maximum or near maximum performance.

Suitable deck flanges, flue systems and anti-downdraft cowls must be used.

CONTROLS

The output of the stove is regulated by the amount of oil allowed to go into it and this function is controlled by the -:

OIL CONTROL VALVE (O.C.V.), Turning the knob anti clockwise controls the oil flow.

2. SAFETY.

Take care to make sure that all safety and ventilation issues are adequately addressed.

FUMES

Always fit a suitable Smoke and Carbon Monoxide alarm within 1.5meters of the appliance.

Make sure that the function is checked on regular basis. (weekly)

Make sure that the alarm can be heard in the sleeping quarters.

Here are the main causes of fume or smoke to leak from the stove.

- The chimney is blocked.
- There are too many bends in the chimney.
- The above deck chimney extension is not high enough.
- The boat is moored in a position near to high buildings or trees and downdraughting is occurring.
- The chimney or parts of it are not airtight.

- There are unusually strong cross winds.

If down draughting occurs turn the appliance off until the winds subside and do not attempt to re-ignite the appliance until it has completely cooled down.

When it has cooled down, before attempting to ignite the appliance remove the catalyser and examine the base of the pot to make sure that there is no oil left in the pot, if there are signs of oil in the pot do not attempt to ignite the appliance until it has been completely dried out.

FIRE

Fire can be caused by a variety of potential danger points and because of the space limitation on boats; this risk is ever present and must be adequately assessed.

The main danger is the effects of heat from the stove on combustible materials and boat occupants.

Make sure that all combustibles are adequately protected from the effects of heat radiation.

Appliances must stand on a fireproof base of minimum thickness 30mm or a purpose made stand.

Floors in front of the stove must have suitable fire protection.

Built in stove heat shields should not be removed under any circumstances.

BURNS

During normal, day-to-day use, many parts of the stove, pipe work, and chimney will become too hot to touch.

Hot surfaces must be adequately protected to prevent anyone falling on to, or touching them.

Suitable fireguards for the appliance and chimney must be fitted.

Fireguards must comply with BS6539.

Always use heatproof gloves when working on or near to a hot stove.

CLEARANCES FROM COMBUSTIBLES

The appliances must be fitted in line with the distances specified in the tables.

All hearths and fireplaces must be made from non-combustible materials and adequately designed for the job.

CLEARANCES FROM COMBUSTIBLES-FLUE PIPES

Flue pipes must be fitted in line with the distances specified in the table and must be suitable for the individual application.

Any combustible materials within the specified distances from the appliances must be protected by a suitable heat shield.

Protection can be gained by the use of -:

- Sheet metal heat shields and spacers.
- Heat resistant boards such as TAC board.
Combustible materials can be-:
- Wooden furniture.
- Curtains.
- Wooden panels or frames adjacent to the flue pipe or where it passes through the deck of the boat.
- Carpet or flooring close to the stove.
- Items near to the stove, which could fall onto it and ignite, should the boat suffer a slight impact or collision.

VENTILATION.

Ventilation plays a vital role in the fitting and sighting of any stove.

The provision of ventilation for these appliances is adequately covered by the requirements of the boat safety scheme.

25cm sq. minimum permanent ventilation, directly to outside air, must be provided.

FLOODED VAPOURIZING BURNER POTS.

When attempting to light any of the appliances, make sure that the pot is not flooded with oil by looking into the base of the burner.

If it is flooded remove the excess oil.

Never try to relight a hot stove; wait until it has cooled down.

Hot oil vapour is explosive.

Never try to light a flooded pot.

SECURELY FIX THE APPLIANCE

The stove must be securely fastened down so that it can resist impact or collision and it must be level in both directions.

Level the stove in both directions when the vessel is midway between its maximum and minimum trim conditions.

Bubble appliances must not be fitted if the maximum angle of trim exceeds 0.75 deg forward to aft or port to starboard.

Only suitably qualified persons can install unvented plumbing systems.

A suitable and serviceable fire extinguisher should always be readily accessible.

3. CHIMNEY

This is the one of the most interesting problems the installer has to deal with and as the chimney affects most aspects of running the stove, we take time here to list the following information for your consideration.

The power, (*suck or vacuum the chimney can develop*) depends upon the following-:

THE HEIGHT.

THE DIAMETER.

THE TEMPERATURE OF THE GASSES IN IT.

THE RESISTANCE OF THE INNER SURFACE OF THE FLUE PIPE OR PIPES.

THE TYPE OF TERMINAL.

THE PREVAILING ATMOSPHERIC CONDITIONS.

It is obvious that on a boat all the above elements are in short supply.

Normally, we have low flues which are small in diameter and generally not very well insulated, coupled with all these problems we have another one, which is that the boat moves across constantly changing surroundings, through locks, into headwinds and crosswinds, all creating major opportunity for down draughting to occur.

Any bend in any part of the chimney or roughness on the internal chimney wall will slow down the velocity of rising gases and reduce the effectiveness of the chimney.

Any slight reduction in the flue gas temperature will reduce the chimney vacuum or pull, hence when the stove is slowed down for all night burning, as the flue gas cools down the chimney vacuum reduces and as the chimney vacuum drops, the stove may well start to burn sooty. This problem is highlighted even more during very cold weather when the chimney can cool down even faster. In these situations careful attention to servicing and low fire setting is essential.

THE CHIMNEY RULES.

1. Always use a top outlet for flue pipe take off.
2. Always try to get the stove as low as possible in the boat, this will allow installation of maximum length flue pipe.
3. Clean or have the chimney cleaned regularly. (Frequency depends upon type of fuel and length of time used).

4. FUEL SUPPLY.

There are several problems relating to diesel fuel supply, which need be adequately addressed.

WAXING

Cold weather waxing or thickening alters the flow characteristics of diesel.

An adequate fuel feed supply can turn into an inadequate one when the temperature starts to fall.

The worst scenario is fuel feed pipe 50-60 feet long in 8mm dia pipe.

The best-case scenario is a fuel pipe 4 feet long in 10mm dia with insulated lagging.

AIR LOCKS

Air lock in oil feed pipe work must be avoided.

The pipe work must slope down to the appliance and be clipped level at 500mm intervals to prevent sagging.

Any rises in the pipe work will cause air locks on commissioning and after future oil run out situations, if it is not possible to run the pipe work in a steady slope then where changes occur a vertical venting leg should be fitted.

TRIM

Bubble appliances must not be fitted if the maximum angle of trim exceeds 0.75 deg forward to aft or port to starboard.

Level the stove in both directions when the vessel is midway between its maximum and minimum trim conditions.

A minimum pressure head of 254mm (10") is required.

This head is measured from the base of the oil tank to the top of the oil control valve. In some cases this head can be affected by the ballast or trim of the boat.

Take great care to try out all the different ballast and trim possibilities to make sure that adequate oil feed is always available at the outlet end of the fuel pipe before it enters the oil control valve at the stove.

TANK

If the stove is fitted at the bow of the boat, a bow tank is recommended.

The tank should comply with the requirements of the boat safety scheme and have:-

- A conveniently sized filler
- A means of venting.
- A conveniently located, easily visible, contents gauge.
- An isolation valve
- An easily replaceable cartridge filter.
- A suitable and substantial water trap

Do not use glass filter bowls, they are not acceptable under the boat safety scheme.

Make sure that your fuel supplier supplies you with appropriate fuel for wintertime running.

OIL LINE

The oil feed line starts after the fuel filter and proceeds to the point of entry, which is where the oil line goes into the cab or saloon of the boat.

The diameter of the oil line is dependent upon the length of run. See 3-2 on waxing and make sure that you have suitably sized compression fittings available.

At this point it is necessary to fit a 60 DEG C, remote sensing fire valve, designed to shut off the oil supply, should a fire occur near to the stove.

If the bubble stove is fitted up to the first bulkhead it will be necessary to fit the isolation valve outside the cabin or saloon of the boat. 5. Make sure that you have purged the oil feed line of all air and there is a steady and constant flow of oil available at the inlet to the oil valve. Make sure that all or any oil isolation devices are turned to the on position. Remember that the oil valve needs a min head of 300mm for gravity feed. When feeding from rear tanks with appliances fitted forward always be aware of the forward - aft trim of the vessel.

Do not use syphonic oil feeds to Bubble Appliances, oil should be fed by gravity or pumped via an appropriate pressure pump = head pressure less than 99mbar.

WATER CONTAMINATION

Because of the high risk of fuel contamination with water, we strongly recommend the fitting of a **high volume water trap**, in the oil supply line.

REMOTE SENSING FIREVALVES

There are two situations where a remote sensing firevalve should be fitted.

1. For fire protection fit a 60 deg C valve.
2. For over boil protection fit an additional 90 deg C valve.

For fire protection a remote sensing fire valve should be fitted as detailed in fig 3.

Run the capillary tube with the oil line up to the stove and carefully fit the sensing phial as follows

B1 Half Pod, B1 Oven and B2 at a low level fitted on two 15mm pipe clips.

Corner Stove and Corner Oven Stove on 15mm pipe clips in front of the drip tray on the fireplace hearth, directly in front of the combustion air restrictor.

Before it is fitted try the fender on the stove to make sure that the fender does not foul the sensing phial.

The sensing phial may be visible through the bottom of the fender, to mask it, paint it with matt black paint available from our sales desk.

When fitting the fire valve make sure that where the capillary and oil line go through the bulkhead in separate sleeved tubes, so that the capillary can be withdrawn separately should it ever need replacing.

For fitting of long oil feed lines which pass through bulkheads and various other parts of the boat it may well be necessary to fit more than one fire valve, especially where the oil line passes through an area where a fire could occur i.e. kitchen area etc.

ISOLATION VALVES.

Two isolation valves are required, one fitted directly into or close to the oil control valve to allow you or the service man to turn the oil off should the need arise, and one fitted directly into the oil tank before the fuel filter.

Always turn off the oil isolation valve serving the appliance before leaving the vessel unattended.

SLEEVING.

Where the oil line goes through the boat superstructure a suitable bulkhead fitting must be used.

OVERBOIL OR OVERHEAT PROTECTION OF THE APPLIANCE.

Where appliances are not fitted with an automatic thermostat an additional 90 DEG C, remote sensing

fire valve must be fitted directly in front of the oil control valve and the sensor from this valve has to be attached to the water jacket or the hot outlet pipe from the boiler.

The valve is calibrated to shut the oil supply down should the water temperature exceed 90 Deg C.

There is a re set button on the remote sensing fire valve which needs to be pressed in to re set the valve after it has tripped off.

4A LIGHTING & COMMISSIONING

A relevant oil control valve catalogue is supplied with each appliance and details of high and low fire adjusting screws are illustrated.

On the Toby valve the low fire screw is clearly visible as per TOBY MANUAL FIG 2

Before trying to light the burner in cold weather it is advisable to pre heat the flue pipe before lighting.

There are two different types of burner fitted to Bubble appliances.

The FB style burner fitted to the **B1 Half Pod, B1 Pie Pod and B2.**

The Socomef burner fitted to the **Corner Stove, Corner Oven Stove** and the **Back Cabin Cooker see sec 4B for lighting Socomef burners.**

1. LIGHTING B1 HALF POD, B1 PIE POD AND B2

When attempting to light the stove these are the rules, which must be followed.

1. Always make sure that the pot is **not** flooded with oil by looking down into the base of the pot.
2. Never try to light the stove if it is flooded with oil.
3. Always check that oil has not leaked from the appliance.
4. Do not light the stove and leave it unattended until it is settled down and stabilized into constant blue flame combustion on low fire. (This could take 10 to 20 minutes.)

On first light up it is advisable to warm the flue pipe up to try and create chimney draft.

Two Ways to Light the Stove

1. Through the lighting port B1 and B2 appliances only,
or
2. Directly into the base of the pot by removing the catalyser.

Lighting into the base of the Pot

On the first light up you may find this option better, as it is possible to see the oil trickle in to the pot more easily.

Use a heatproof glove when putting the catalysers back into the pot and it is important to replace them quickly whilst the flame is small.

Make sure that the oil is turned off.

Open the front door.

Remove the optional coal kit if fitted.

Remove the catalyser.

Turn the oil on and allow a small pool of oil to flow into the pot about the size of a small biscuit, **then turn the oil off.**

Note that on first light up it may take a few minutes for the oil to reach the pot as it has to fill the pipework before reaching the pot, take care not to allow excess oil to flow into the pot.

Light a small piece of firelighter and drop it into the oil, allow a few seconds for it to get going and then replace the catalyser and coal kit if fitted, and close the door.

Wait for approx. 1 minute until the pool of oil is alight and then **turn the oil on** to minimum setting no 1.

Watch the appliance for a few minutes and you will see the flame establish and settle down into blue flame combustion.

Allow the burner to run for a further 10 minutes before turning the appliance up to the higher settings.

If at any time during the ignition process large amounts of flame can be seen, turn the oil off immediately and wait until the flames die down before putting the oil on again at minimum setting.

Manual Lighting through the Lighting Port B1 and B2 appliances.

Check that the isolation valve is turned on.

Open the front door.

Remove the front apron on B1 Half Pod and B1 pie Pod.

Remove the lighting port plug by pulling it out of its tubular socket.

Turn the oil on to the first position via the flow control knob and allow a small pool of oil to flow into the pot about the size of a small biscuit.

Turn the oil off.

Cut a small piece of firelighter and stab it onto the spike.

Light it and push it into the lighting port tube, let the firelighter drop off the spike into the bottom of the pot.

Replace the lighting port plug back into the tube.

Close the front door.

Turn the fuel flow on again at the lowest setting

Watch the appliance for a few minutes until it settles down into blue flame combustion.

Allow the burner to run for a further 10 minutes before turning the appliance up to the higher settings.

If at any time during the ignition process large amounts of flame can be seen, turn the oil off immediately and wait until they die down before putting the oil on again.

Note there may be the occasional growl or audible vibration whilst the burner settles down into blue flame combustion.

COMMISSIONING THE HIGH & LOW FIRE, CHRYSTAL SERIES

Used in B1 Half Pod, B1 Pie Pod and B2

When the burner has established good blue flame combustion turn it up to half output. (Setting 3 on the fuel flow control knob) and let it stabilize.

Allow at least half an hour for the chimney to warm up thoroughly before making any adjustments to the high or low fire screws.

Turn the stove down onto minimum firing rate and let it stabilize.

After stabilization there should be a dull red glow in the lower catalyser with wispy blue flames flicking into and just over it.

If the flame falls into a dirty rolling yellow flame and the catalyser is not dull red then the low fire will need to be increased until it can support the required blue flame combustion.

To increase the low fire oil flow, screw the adjusting screw out by quarter turn increments.

When you are happy with the low fire, set the high fire.

Turn the oil flow knob up to setting 4, let the flame stabilize, and look at it, if it is stable and blue, turn it up slowly using the control knob, letting it stabilize after each movement, if the flame starts to go yellow with long flame combustion, it is running fuel rich and

the high fire screw needs adjusting to reduce the flow of oil. (Screw the adjuster screw in to reduce the high fire oil flow.)

Before adjusting the high fire screw, turn the flame down and let it stabilize in blue flame combustion, adjust the high fire screw by half a turn in and try turning the fuel flow up, if it is still fuel rich repeat the process until the high fire flame is running blue with just flicks of yellow in the tips.

To see a bubble stove running correctly see the following link

<https://www.youtube.com/watch?v=UqdQLFp3HkQ>

4B LIGHTING & COMMISSIONING THE BURNER SOCOMEF SERIES

1. LIGHTING CORNER STOVE, CORNER POD AND BACK CABIN COOKER.

When attempting to light the stove these are the rules, which must be followed.

1. Always make sure that the pot is not flooded with oil by looking down into the base of the pot.
2. Never try to light the stove if it is flooded with oil.
3. Always check that oil has not leaked from the appliance.
4. Do not light the stove and leave it unattended until it is settled down and stabilized into constant blue flame combustion on low fire. (This could take 10 to 20 minutes.)
5. Make sure that you have purged the oil feed line of all air and there is a steady and constant flow of oil available at the inlet to the oil valve. Make sure that all or any oil isolation devices are turned to the on position. Remember that the oil valve needs a min head of 300mm for gravity feed. When feeding from rear tanks with appliances fitted forward always be aware of the forward - aft trim of the vessel.
6. Do not use syphonic oil feeds to Bubble Appliances, oil should be fed by gravity or pumped via an appropriate pressure pump = head pressure less than 99mbar.

On first light up it is advisable to warm the flue pipe up to try and create chimney draft.

Lighting the Stove

Lighting the stove takes a little time and patience; the following procedure should be adopted.

In the case of the Corner appliances, open the front door and in the case of the Back Cabin Cooker remove the hot plate and top baffle to gain access to the

burner, note that the back cabin cooker has a lighting port fitted behind the lower ash pit door.

Remove the coal kit if it has been supplied with the stove.

Lift the inner mesh catalyser from the burner.



Look into the bottom of the pot and turn the oil on at full rate, allow oil to flow into the bottom of the pot to form a pool about the size of a small digestive biscuit and then turn the oil off.

Note that on first light up it may take a few minutes for the oil to reach the pot as it has to fill the pipework before reaching the pot.

Do not allow any depth of oil to build up.

Light a small piece of firelighter (about the size of a pineapple chunk) and place it into the centre of the oil pool.

Replace the mesh catalyser and the coal kit, if fitted and then leave the door slightly open whilst the firelighter gets the oil going.

After 30 to 40 seconds, you will notice the flame start to establish itself and spread around the bottom of the pot.

When this occurs, close the door or replace the baffle and top plate and then turn the oil on to its minimum setting.

After two or three minutes the flame should slowly change from yellow into blue flame combustion and settle down to a steady burn.

Note there may be the occasional growl or audible vibration whilst the burner settles down into blue flame combustion.

Allow the burner 10 - 15 minutes to stabilise and the increase the flow of oil as required, moving by one increment of the dial only.

Do not leave the appliance unattended during the lighting and stabilising procedure.

COMMISSIONING THE HIGH AND LOW FIRE SOCOMEF BURNERS.

Corner Stove, Corner Pod and Back Cabin Cooker.

Note that Back cabin Cookers are pre commissioned at the factory and do not need adjusting.

A relevant oil control valve catalogue is supplied with each appliance and details of high and low fire adjusting screws are illustrated.

On the Toby valve the low fire screw is clearly visible as per TOBY MANUAL FIG 2

When the burner has established good blue flame combustion turn it up to half output. (Setting 3 on the fuel flow control knob) and let it stabilize for a minute. Allow at least half an hour for the chimney to warm up thoroughly before making any adjustments to the high or low fire screws.

Turn the stove down onto minimum firing rate and again let it stabilize.

After stabilization there should be a dull red glow in the catalyser with wispy blue flames flickering just over the top of it, approximately level with the top of the pot.

If the flame falls into a dirty rolling yellow flame and the catalyser is not dull red then the low fire will need to be increased until the burner can support the required blue flame combustion.

When you are happy with the low fire, set the high fire.

Turn the oil flow knob up to setting 4, let the flame stabilize, and look at it, if it is stable and blue, turn it up slowly using the control knob, letting it stabilize after each movement, if the flame starts to go yellow with long flame combustion, it is running fuel rich and the high fire screw needs adjusting to reduce the flow of oil. (Screw the adjuster screw in to reduce the high fire oil flow.)

Before adjusting the high fire screw, turn the flame down and let it stabilize in blue flame combustion, adjust the high fire screw by half a turn in and try turning the fuel flow up, if it is still fuel rich repeat the process until the high fire flame is running blue with flicks of yellow in the tips.

On the Socomef pot, the high fire flame will be set approx. 40mm above the top of the pot.

NOTE THAT THIS PROCEDURE WILL NOT BE POSSIBLE IF THE CHIMNEY RULES HAVE NOT BEEN ADHERED TO.

THE HIGH FIRE SETTING WILL HAVE TO BE ADJUSTED IN LINE WITH THE AVAILABLE GENERATED CHIMNEY VACUUM IE

THE FLUE PIPE MUST BE A MINIMUM OF 1.8 METERS HIGH FOR LOW FIRE AND 2.1 METERS FOR HIGH FIRE.

INSTALLING ENGINEERS SHOULD NOT LEAVE THE APPLIANCE UNDER THE CONTROL OF THE CUSTOMER UNLESS THE APPLIANCE HAS BEEN CORRECTLY COMMISSIONED.

TO SEE HOW THE BURNER SHOULD OPERATE COMMISSIONING AND INSTALLING ENGINEERS SHOULD VISIT

<https://www.youtube.com/watch?v=UqdQLFp3HkQ>

This video shows a stove running from low to high fire and back to low fire. Note that this video is filmed on a normal house chimney and so it may not be possible to get exactly the same conditions on a typical boat flue as the fuel air ratio will not be exactly the same, hence the need for fine tuning the oil flow to the chimney air flow capability.

5. FIREPLACE.

Unless one is built into the appliance, always fit appliances on a suitable drip tray.

The possibility of oil drops leaking from the stove must be considered; a suitable oil drip tray must be fitted and designed in such a way, as it will contain any oil leaks or drips.

Normally the tray will cover the footprint of the stove, the oil valve and isolation device.

It will be oil tight and have a vertical up stand of at least 30mm. This should give a minimum containment volume of 2 litres.

It will be securely fastened down to the vessel and the appliance must be securely fastened down to the oil drip tray.

Make sure that drip trays are tested to ensure that they do not leak when filled with oil.

The hearth must be:-

FLAT - SECURE - FIREPROOF AND LEVEL IN BOTH DIRECTIONS.

Use materials, which are easy to keep clean and fireproof such as tiles, asbestolux or vermiculite boarding with a suitable weight resistant liner.

The vertical walls of the fireplace must also be made from fireproof materials.

Use fireproof, rockwool infill behind the fireplace panels to protect any combustible insulation materials

such as spray foam.

6. DISTANCES FROM COMBUSTIBLES (APPLIANCES)

Stove Type	ABOVE	SIDES.	BACK	FRONT	HEARTH Non Combustible Material
B1 HALF POD and OVEN VERSION	500	300	150 FROM HEAT SHIELD	300 to allow door opening.	30MM THICK x 100 projection at the front and sides
BOAT B2	600	300	150 FROM HEAT SHIELD	300 to allow door opening.	30MM THICK x 100 projection at the front and sides
CORNER and OVEN VERSION	500	75	100 FROM HEAT SHIELD	300 to allow door opening.	30MM THICK x 100 projection at the front.
BACK CABIN COOKER	500	150	100 FROM HEAT SHIELD	300 to allow door opening.	25MM THICK x 150 projection at sides

7. DISTANCES FROM NON COMBUSTIBLES (APPLIANCES)

Stove Type	ABOVE	SIDES.	BACK	FRONT	HEARTH Non Combustible Material
B1 HALF POD and OVEN VERSION	300	150	150 FROM HEAT SHIELD	300 to allow door opening.	30MM THICK x 100 projection at the front and sides.
BOAT B2	300	150	150 FROM HEAT SHIELD	300 to allow door opening.	30MM THICK x 100 projection at the front and sides.
CORNER and OVEN VERSION	200	150	25 FROM HEAT SHIELD	300 to allow door opening.	30MM THICK x 100 projection at the front and sides.
BACK CABIN COOKER	500	75	50 FROM HEAT SHIELD	300 to allow door opening.	25MM THICK x 75 projection at sides

Note that the back cabin cooker can have the oil control valve fitted to the rear or the left hand side in each case the positioning of the valve will affect the fireplace and spacing considerations, see sizes of cooker to establish requirements.

8. DISTANCES FROM COMBUSTIBLES (FLUE PIPES)

For all appliances-:

1. Single skin flue pipes. Horizontal Distance = 50mm **when fitted within the deck flange** at the top of the chimney system, protected by the fire stop spacer.
2. Single skin flue pipes. Horizontal Distance = 150mm **when exposed in the saloon or living space.**
3. Twin Wall Insulated flue pipes. Horizontal Distance = 30 mm for insulated flue pipe systems.

9. ILLUSTRATIONS

FIG 1. STOVE DISTANCE FROM COMBUSTIBLES

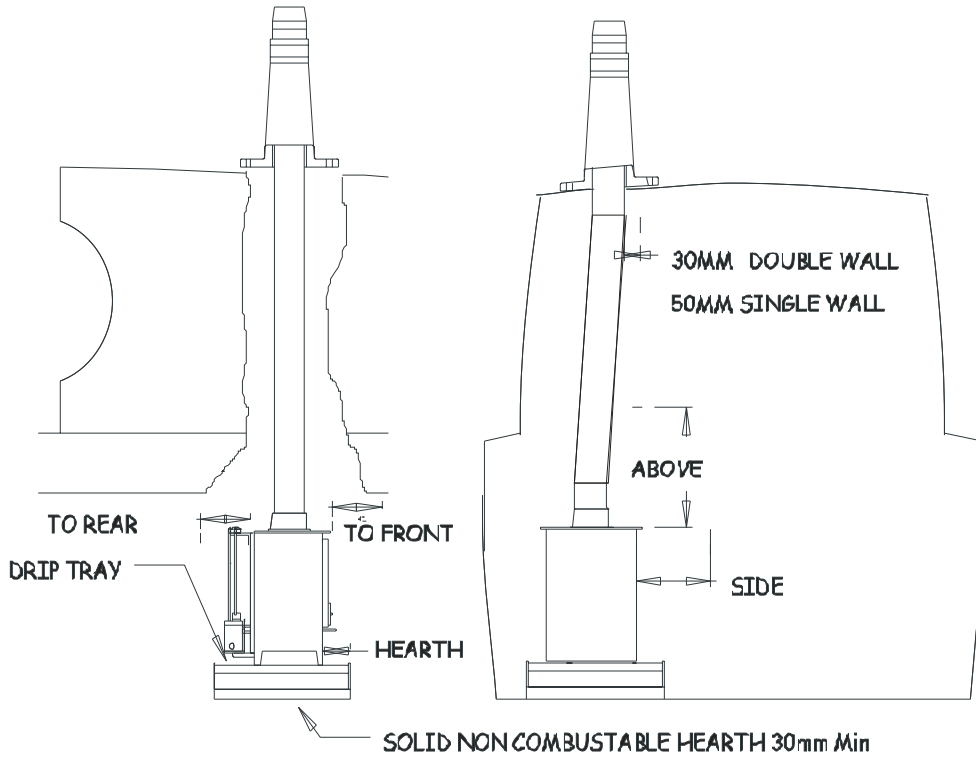

FIG 2 BUBBLE MK1 FABRICATED DECK FLANGE LAYOUT

Note that there is mk3 system which is now available and detailed on our web site.

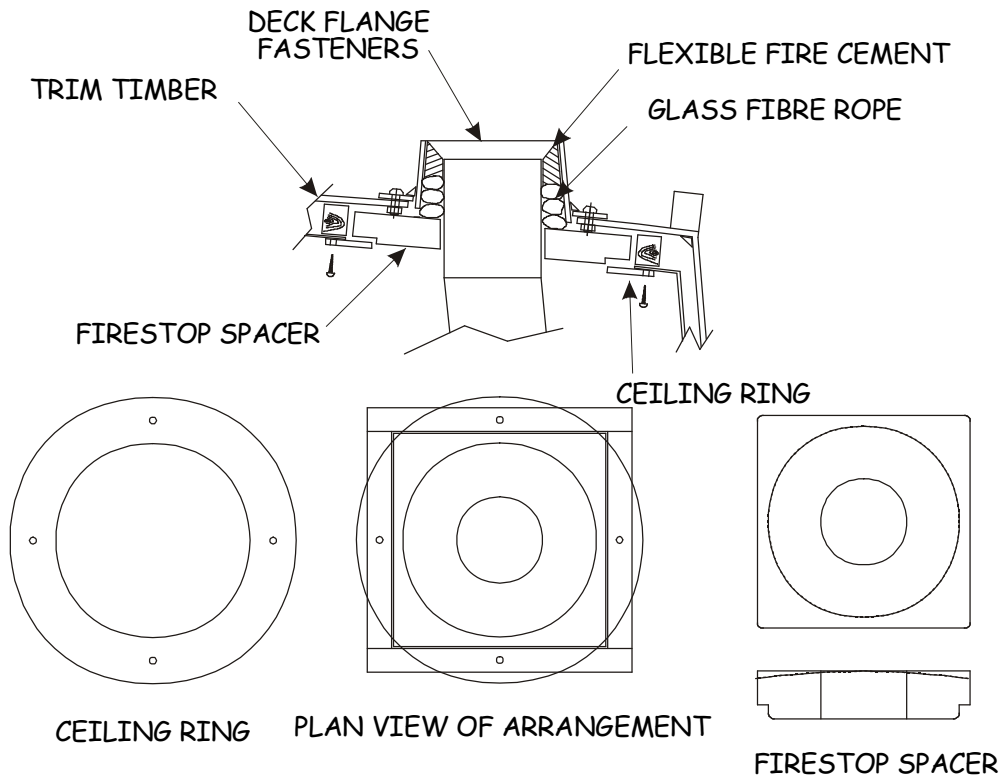
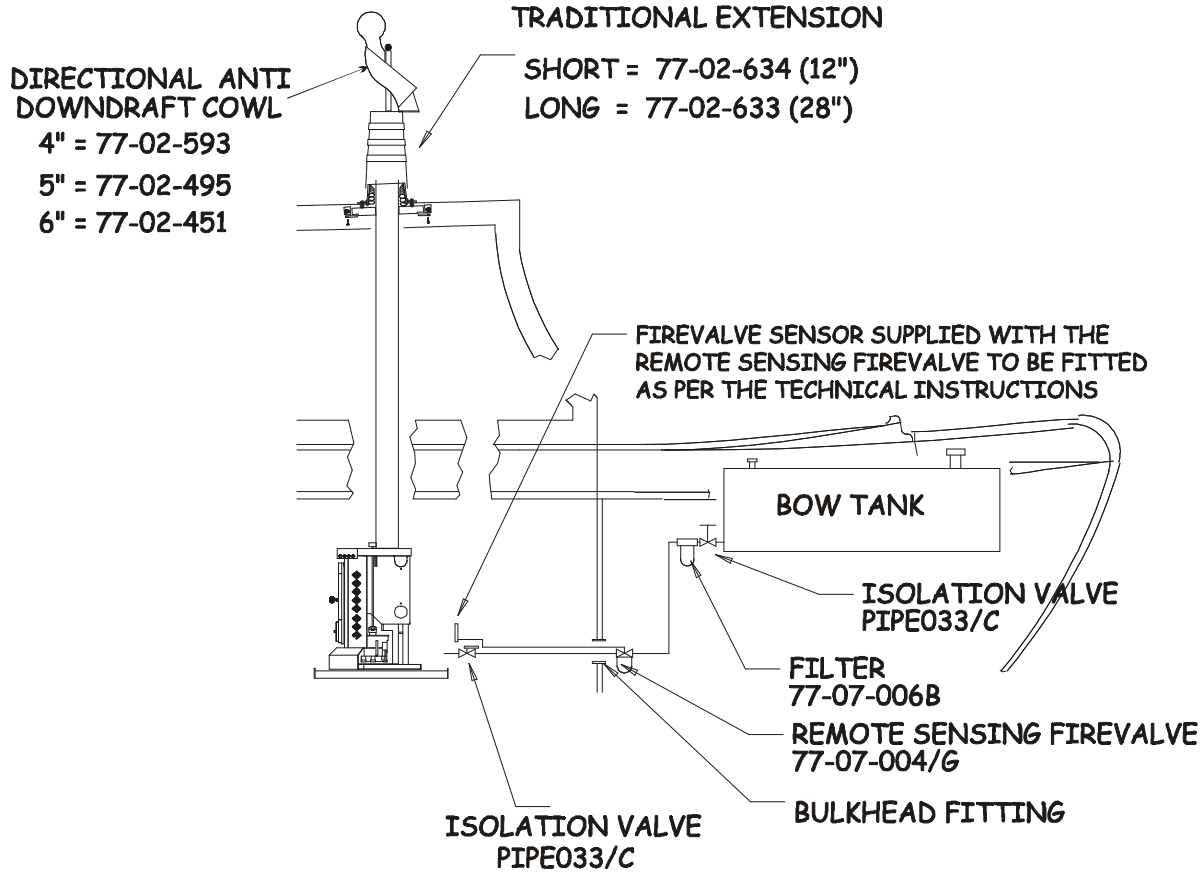

FIG 3 TYPICAL OIL FEED LAYOUT



COPYRIGHT HARWORTH HEATING LTD 080800

FIG 4 TYPICAL PUMING LAYOUTS

Drq 1

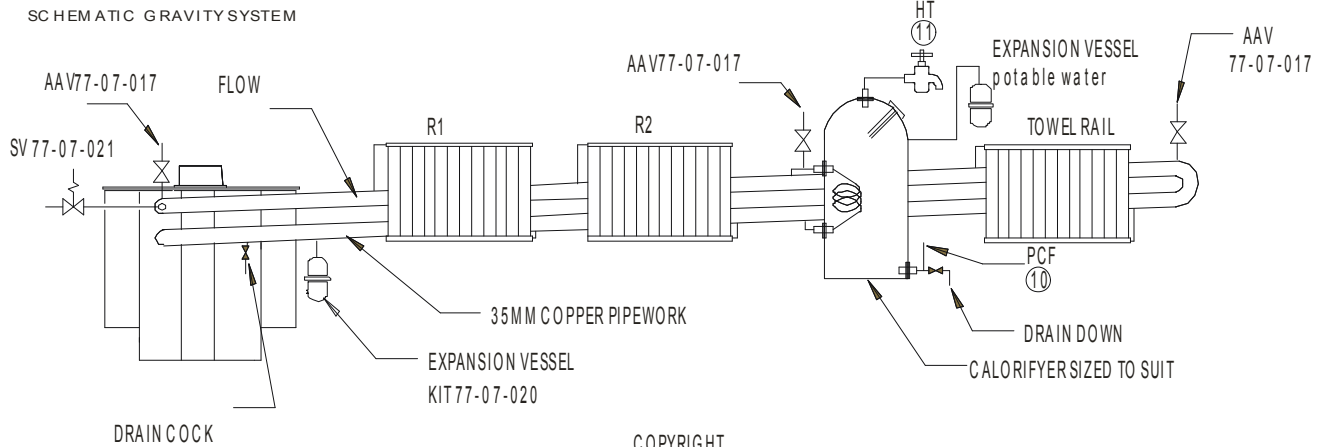

COPYRIGHT BUBBLE PRODUCTS 2013

Drg 2

SCHEMATIC PUMPED SYSTEM ISS 2 OF 28-10-17

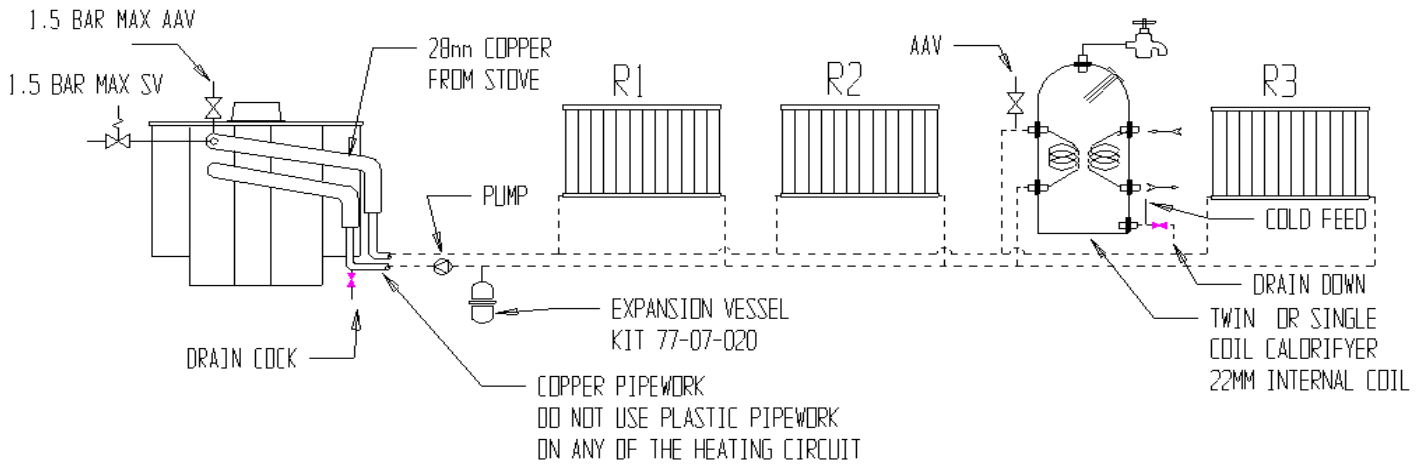

Drg 3

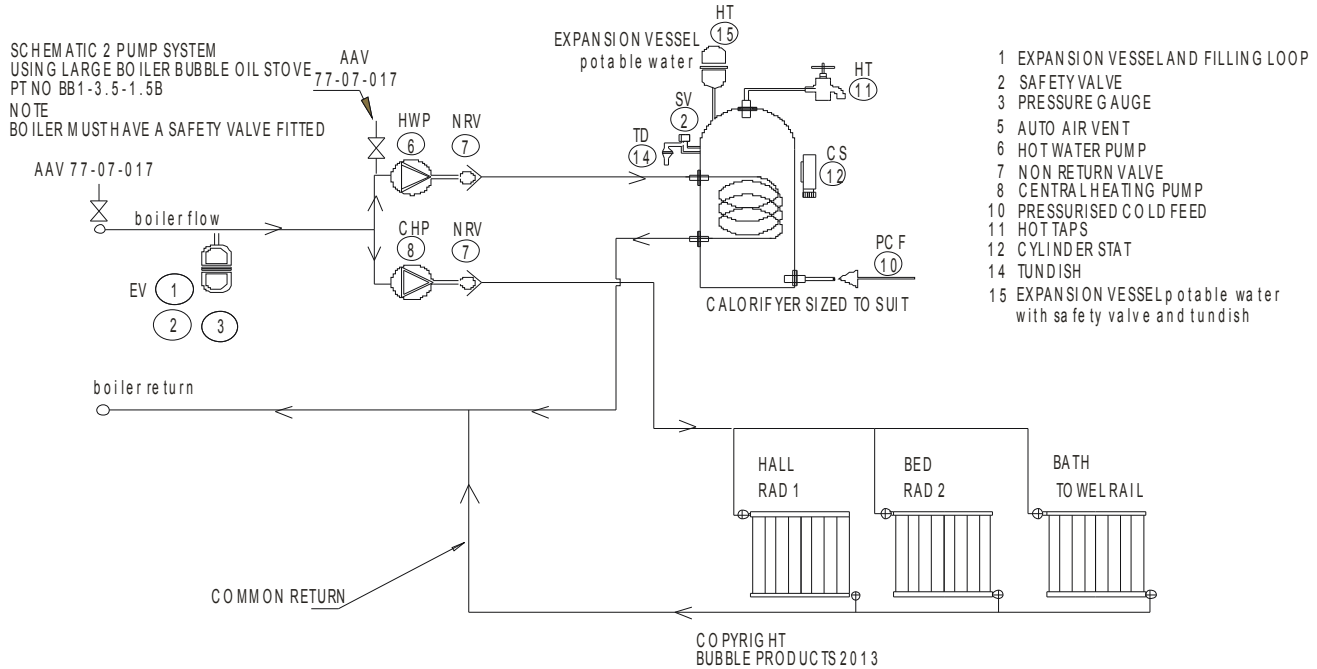

10. STOVE DIMENSIONS

10-1 BB1 HALF POD AND PIE POD DIMENSIONS

Note that the B1 Pie Pod has the same footprint dimensions but the vertical height is 830mm.

**B1 HALF OIL POD OF 12-02-15
OVERALL DIMENSIONS
BOILER AND NON BOILER VERSIONS**

**.WEIGHT 35.KG NON BOILER
.WEIGHT 45.KG SMALL BOILER
.WEIGHT 50.KG LARGE BOILER**

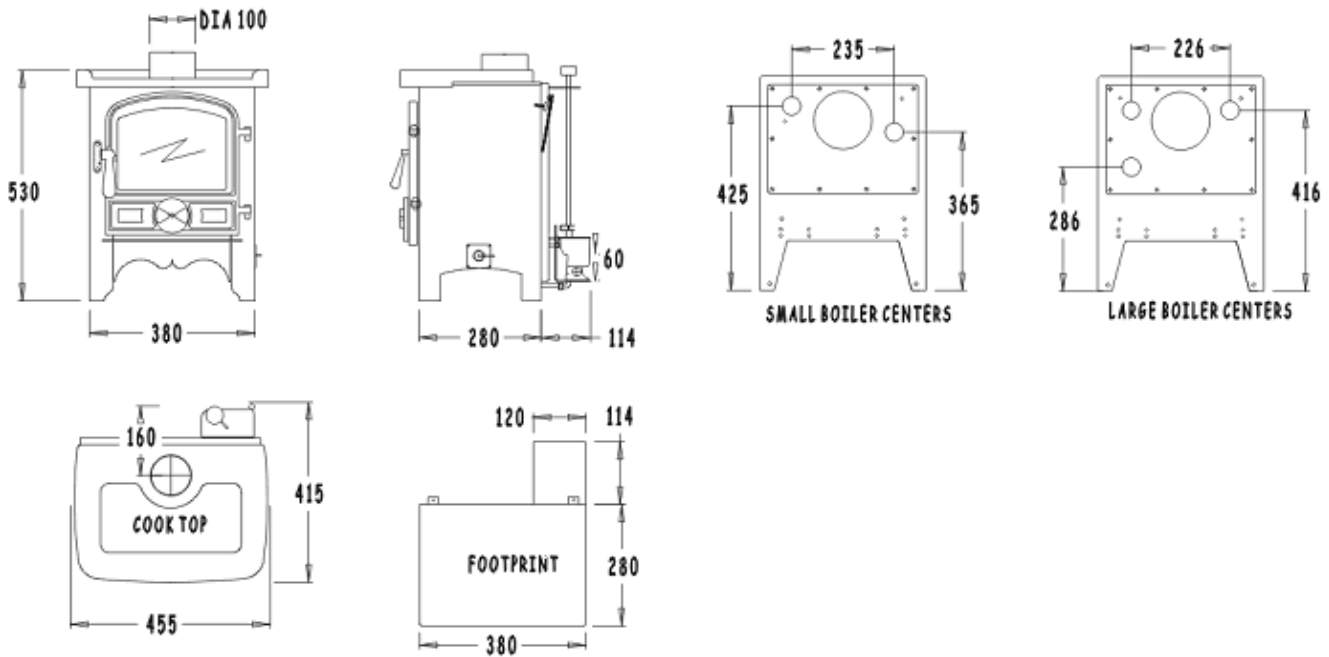

10-2 CORNER STOVE AND CORNER PIE POD DIMENSIONS

Note that the Corner Pie Pod has the same footprint dimensions but the vertical height is 840mm.

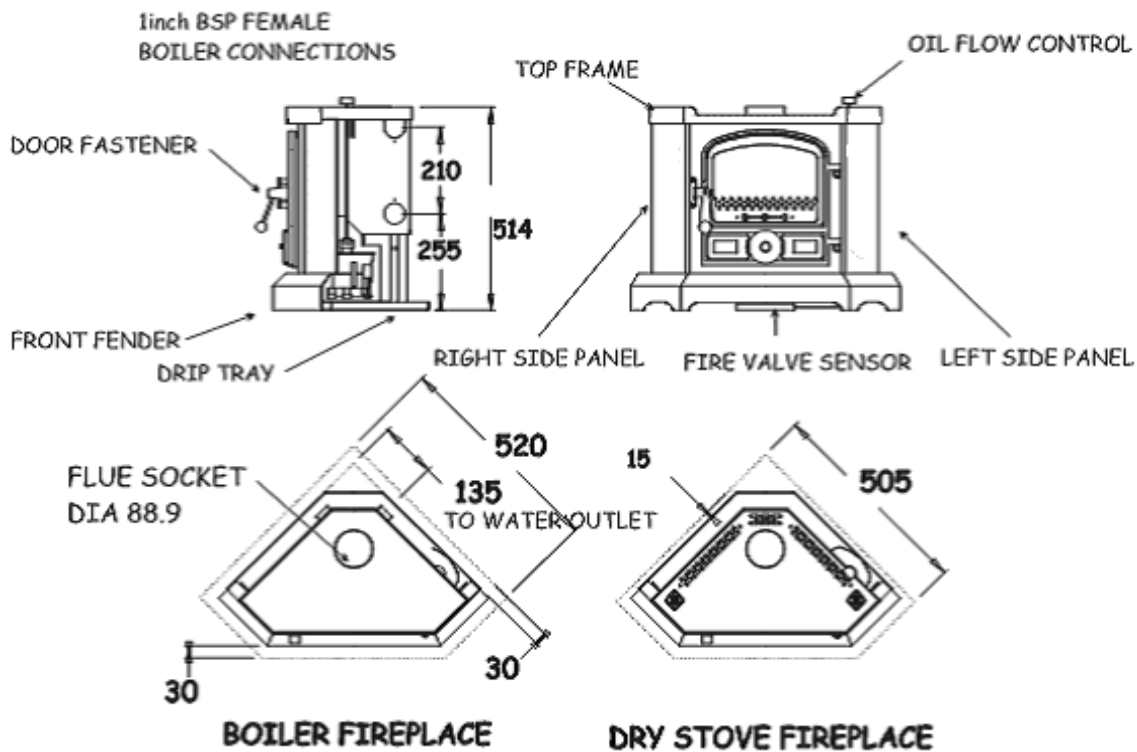

10-3 B2 STOVE DIMENSIONS

Note that the B2 Pie Pod has the same footprint dimensions but the vertical height is 830mm.

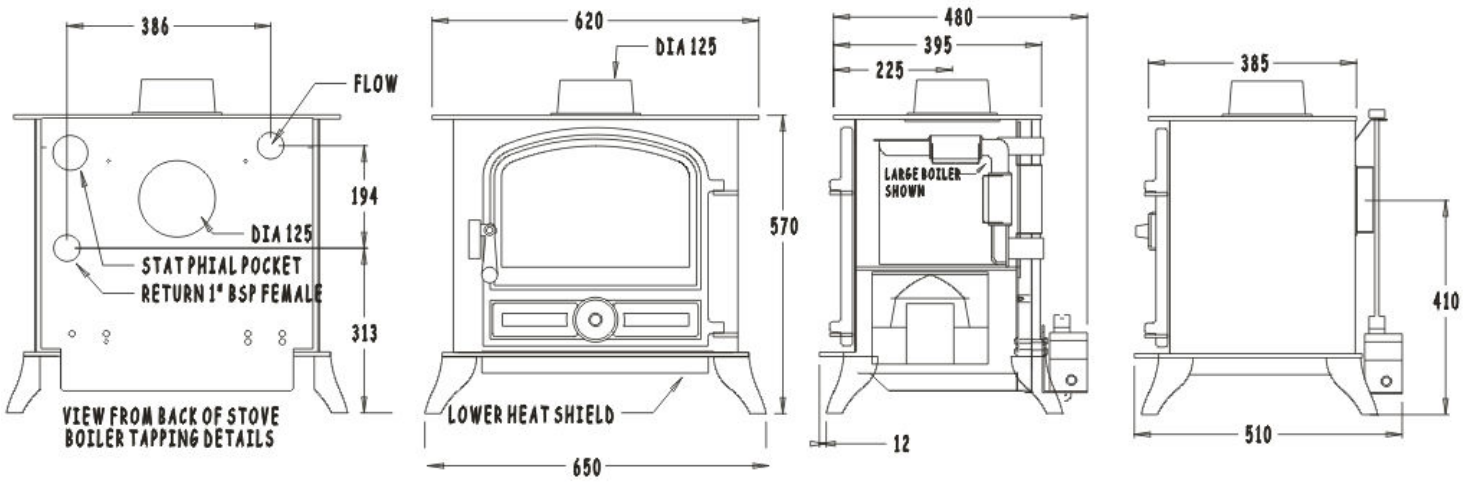

10-4 BACK CABIN COOKER DIMENSIONS

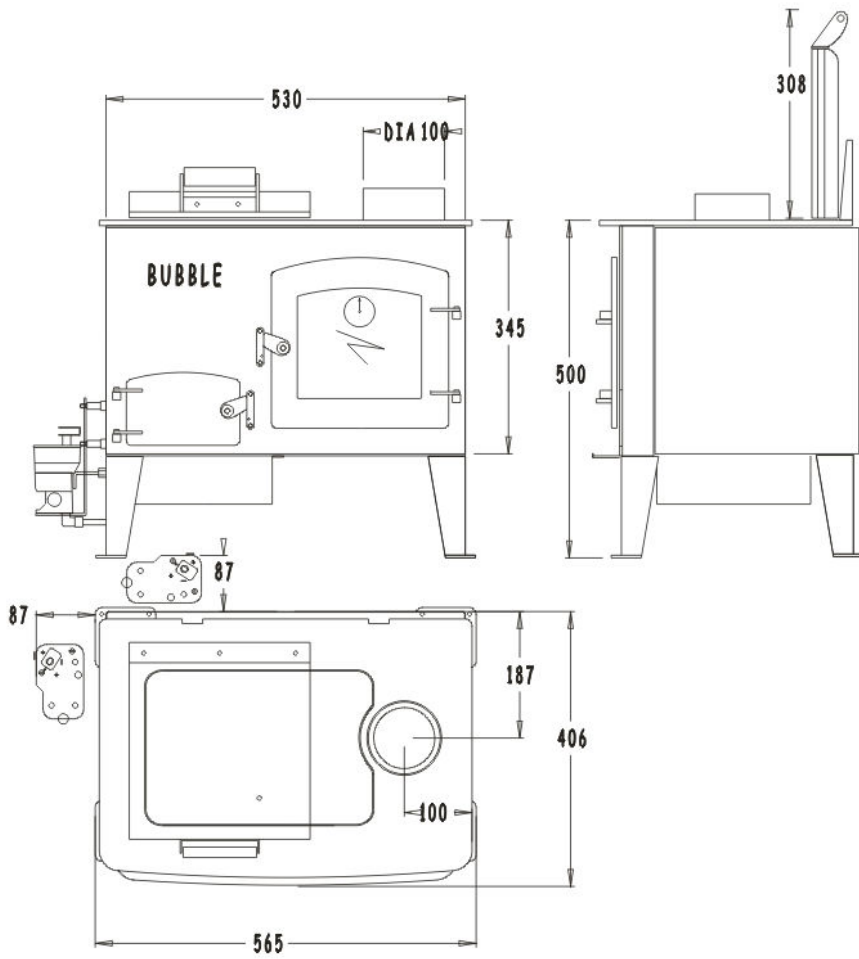

11. OIL CONSUMPTION RATES

		MAX HEAT OUTPUT TO WATER	MAX HEAT OUTPUT TO SPACE	MINIMUM OIL FLOW CC'S PER MIN	MAXIMUM OIL FLOW CC'S PER MINUTE
--	--	--------------------------	--------------------------	-------------------------------	----------------------------------

B1 HALF POD & OVEN DERIVATIVE					
Free Standing	From 1.6kW to 5kW		5kW	4 = (1.6kW)	12 = (5kW)
Free Standing	From 1.6kW to 5kW	2kW	3kW	4 = (1.6kW)	12 = (5kW)
Free Standing	From 1.6kW to 6kW	5kW	2kW	4 = (1.6kW)	13 = (6kW)

CORNER STOVE & OVEN DERIVATIVE					
Free Standing	From 1kW to 4kW		4kW	3 = (1kW)	10 = (4kW)
Free Standing	From 1kW to 4kW	3kW	1kW	3 = (1kW)	10 = (4kW)

BUBBLE 2					
Free Standing	From 1.6kW to 5kW		5kW	4 = (1.6kW)	13 = (5kW)
Free Standing	From 1.6kW to 8kW		8kW	4 = (1.6kW)	16 = (8kW)
Free Standing	From 1.6kW to 8kW	3kW	5kW	4 = (1.6kW)	16 = (8kW)
Free Standing	From 1.6kW to 8kW	9kW	2kW	4 = (1.6kW)	22 = (11kW)

BACK CABIN COOKER					
Free Standing	From 1.6kW to 5kW		3kW	4 = (1.6kW)	7 = (3kW)
Free Standing	From 1.6kW to 5kW	1kW	2kW	4 = (1.6kW)	7 = (3kW)

© HARWORTH HEATING LTD 30.6.98

This publication may not be copied by any means, without written permission from the authors.

These products are subject to continuous development and improvement and it is consequently acknowledged that due to this process there may be some omissions and errors.

This publication is intended only to assist the reader in the use of this product and therefore Harworth Heating Ltd shall not be liable for any loss or damage whatsoever arising from the use of any information, error or omission found in this publication.

The appliances mentioned in this publication can only be installed and serviced by approved personnel.

Approved personnel means that they must HAVE BEEN SUITABLY TRAINED, if there are any

reliability issues reported back to **Harworth Heating** or **Bubble Products**, the installing engineer will be responsible for carrying out any rectification work.

For details of suitable training courses contact: - www.oftec.org

12. NORMATIVE REFERENCES

Boat installation work comes under the control of: -
The Boat Safety Scheme.

This scheme provides statutory requirements and associated EN / BS Standards for most aspects of installation work on boats.

Further information and a copy of the requirements can be obtained from:-

www.boatsafetyscheme.com

Where guidance for oil fired appliances is not readily available from the Boat safety Scheme publication, we then point out a list of standards which pertain to domestic installations and which are generally covered by the latest version of the English Building Regulations Doc J.

When read in conjunction with:-

1. Our installation instructions.
2. The Boat Safety Scheme rules.
3. The other standards detailed, enough information should be provided to allow for a safe installation.

BS 5440	Flues.
BS 6999	Flues
BS 7840	Fuel Hoses.
BS EN1057	Copper Tubes.
BS1344 Part 3 1988 ISO8290 1987	Flues.
BS EN 1443:2003	Chimneys - General requirements.
BS EN1856 part 1 replacing BS 4543	Flues.
BS EN1856 part 2 & BS 715 1993	Flues.
BS 1945: 1971	Stove door
BS EN 10296-1	Steel tubes
BS ISO 10088:2001	
BS EN ISO 9094-2003	
BS EN 10297-1	Steel tubes
BS EN 13384-1	Chimneys
BS EN 10088-1:2005	Stainless steels - Part 1: List of stainless steels

INSTALLATION & GENERAL INSTRUCTIONS



Silent Simplicity just for you!

MARINE OIL STOVES ©

ISSUE 15 @ 22-06-18

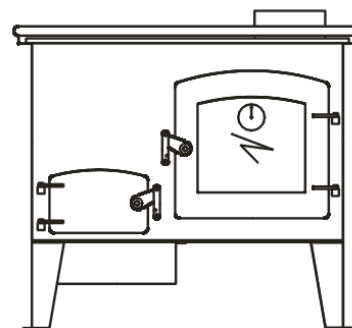
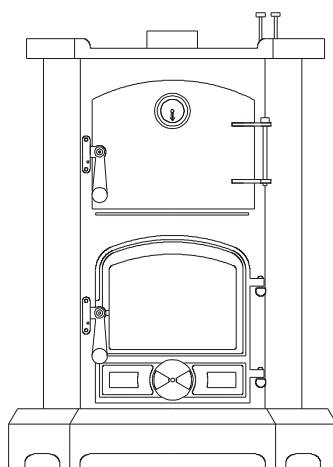
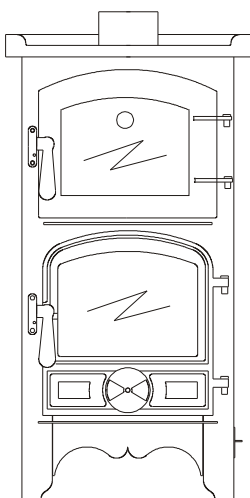
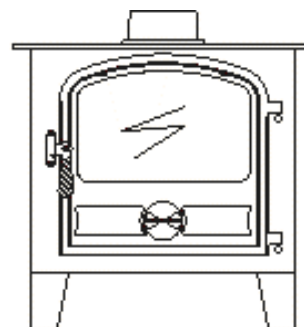
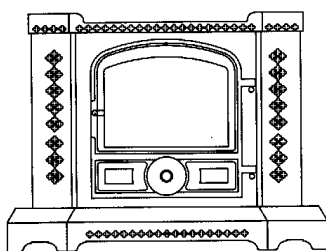
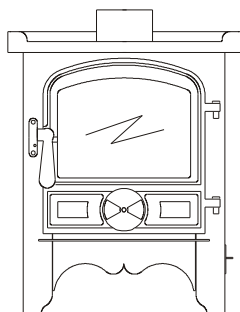

www.harworthheating.co.uk

INDEX

1. BEFORE STARTING THE JOB.	3
FITTING OPTIONS.	3
ABOUT THE APPLIANCES	3
2. SAFETY.	4
FUMES	4
FIRE	4
BURNS	4
CLEARANCES FROM COMBUSTIBLES	4
CLEARANCES FROM COMBUSTIBLES-FLUE PIPES	5
VENTILATION.	5
FLOODED VAPOURIZING BURNER POTS.	5
SECURELY FIX THE APPLIANCE	5
3. CHIMNEY	5
THE HEIGHT.	5
THE DIAMETER.	5
THE TEMPERATURE OF THE GASSES IN IT.	5
THE RESISTANCE OF THE INNER SURFACE OF THE FLUE PIPE OR PIPES.	5
THE TYPE OF TERMINAL.	5
THE PREVAILING ATMOSPHERIC CONDITIONS.	5
THE CHIMNEY RULES.	6
4. FUEL SUPPLY.	6
WAXING	6
AIR LOCKS	6
TRIM	6
TANK	6
OIL LINE	6
WATER CONTAMINATION	6
REMOTE SENSING FIREVALVES	7
ISOLATION VALVES.	7
SLEEVING.	7
OVERBOIL OR OVERHEAT PROTECTION OF THE APPLIANCE.	7
4A LIGHTING & COMMISSIONING	7
1. LIGHTING B1 HALF POD, B1 PIE POD AND B2	7
COMMISSIONING THE HIGH & LOW FIRE, CHRYSTAL SERIES	8
4B LIGHTING & COMMISSIONING THE BURNER SOCOMEF SERIES	9
1. LIGHTING CORNER STOVE, CORNER POD AND BACK CABIN COOKER.	9
COMMISSIONING THE HIGH AND LOW FIRE SOCOMEF BURNERS.	10
5. FIREPLACE.	10
6. DISTANCES FROM COMBUSTIBLES (APPLIANCES)	11
7. DISTANCES FROM NON COMBUSTIBLES (APPLIANCES)	11
8. DISTANCES FROM COMBUSTIBLES (FLUE PIPES)	11
9. ILLUSTRATIONS	12
FIG 1. STOVE DISTANCE FROM COMBUSTIBLES	12
FIG 2 BUBBLE MK1 FABRICATED DECK FLANGE LAYOUT	12
FIG 3 TYPICAL OIL FEED LAYOUT	13
FIG 4 TYPICAL PUMBING LAYOUTS	13
10. STOVE DIMENSIONS	14
10-1 BB1 HALF POD AND PIE POD DIMENSIONS	14
10-2 CORNER STOVE AND CORNER PIE POD DIMENSIONS	15
10-3 B2 STOVE DIMENSIONS	15
10-4 BACK CABIN COOKER DIMENSIONS	16
12. NORMATIVE REFERENCES	18

If you have any difficulties please phone our technical help line on-:

01302 742520 fax 01302 750573

e-mail contact@bubbleproducts.co.uk

<http://www.bubbleproducts.co.uk>

1. BEFORE STARTING THE JOB.

THE FOLLOWING NOTES PROVIDE INFORMATION FOR INSTALLATION OF THE FOLLOWING APPLIANCES.

Boat Bubble No 1 AND HALF POD, Dry Small and Large Boiler Appliances

Boat Bubble No 2 Dry Small and Large Boiler Appliances

Marine Corner Bubble Wet and Dry appliances

Bubble No 1 Cooking Stove plus boiler options.

Corner Cooking Stove plus boiler options.

Back Cabin Oil Fired Cooker.

FITTING OPTIONS.

There are normally two different situations that the installer may be faced with:-

1. A new build installation.

An established boat installation, (which has not had oil stove fitted).

2. A replacement installation, where there has been a solid fuel stove fitted previously.

Each of the situations will present differing problems which will be:-

- Where to locate the stove.
- How to deal with fireplace design.
- Where to locate the oil tank.
- How to get an oil supply to the stove.
- How to fit the chimney.
- How to connect water to the stove.
- How to disconnect and remove the stove, easily.

The new build situation should be the easiest.

The established boat situation will require careful attention to the sighting of the stove in relation to flue positions and existing fittings positions.

In replacement situations it may well be necessary to blank off the existing through roof flue position and cut a fresh one to suit the new location and comply with our instructions on flue design.

ABOUT THE APPLIANCES

Generally described as a space heater or space heater and cooker, which burns diesel oil in a controlled

manner utilizing a chimney to discharge the products of combustion.

The appliance generates heat from burning oil mixed with air in a vaporizing pot located in the bottom of the stove.

Once the appliance has been ignited, oil goes into the pot at a steady and controlled rate via a gravity feed which is metered by the OIL CONTROL VALVE; the oil flow can be controlled from minimum to maximum or any setting in between determined by the set position of the oil flow control knob.

Air is sucked into the pot by the natural action of the negative pressure in the chimney.

To allow the chimney to work correctly it is essential that you have adequate, unrestricted ventilation into the area where the stove is situated.

The amount of oil that can be successfully burned is directly proportional to the amount of air that the chimney can draw into the pot and so to achieve adequate combustion a balanced and appropriate flow of both oil and air is required.

The stove will provide space or combined space and water heating and in some cases cooking as well.

Where cooking and water heating are combined one feature will inevitably effect the other.

There are different versions of each appliance within the total range.

Some of the appliances are supplied as Dry, Small Boiler and Large Boiler versions namely B1 Half Pod, B1 Oven and B2.

Some of the appliances are supplied just as Dry and Large Boiler versions namely Corner Stove and Corner Oven Stove.

The Back Cabin Cooker can be supplied with or without a small boiler for domestic hot water heating only.(1kw)

All of the boilers are high water content and suitable for pumped or gravity systems and pressurised or open vented systems ASSUMING THAT THEY ARE INSTALLED BY SUITABLY QUALIFIED PERSONS.

All the appliances are fitted with a descaling device which should be rotated on a two weekly cycle to descale the oil inlet pipe.

Where applicable, appliances must not be operated with the glass front door opened or cracked, or without the lighting port plug fitted.

Where applicable, the door glass may require light cleaning occasionally depending upon the continuous running time of the stove.

Appliances must be securely bolted down to resist impact or collision and must be level in both directions.

All the appliances are supplied with clamp down brackets except the Back Cabin Cooker which must be fastened down through the foot plates.

The top of the appliances can be used for warming and cooking.

The oven appliances have a comprehensive range of cooking facilities with both oven and hot plate cooking available.

Some appliances can also be supplied with a coal kit, which just like a solid fuel stove, coal effect will only be available when the stove is running at maximum or near maximum performance.

Suitable deck flanges, flue systems and anti-downdraft cowls must be used.

CONTROLS

The output of the stove is regulated by the amount of oil allowed to go into it and this function is controlled by the -:

OIL CONTROL VALVE (O.C.V.), Turning the knob anti clockwise controls the oil flow.

2. SAFETY.

Take care to make sure that all safety and ventilation issues are adequately addressed.

FUMES

Always fit a suitable Smoke and Carbon Monoxide alarm within 1.5meters of the appliance.

Make sure that the function is checked on regular basis. (weekly)

Make sure that the alarm can be heard in the sleeping quarters.

Here are the main causes of fume or smoke to leak from the stove.

- The chimney is blocked.
- There are too many bends in the chimney.
- The above deck chimney extension is not high enough.
- The boat is moored in a position near to high buildings or trees and downdraughting is occurring.
- The chimney or parts of it are not airtight.

- There are unusually strong cross winds.

If down draughting occurs turn the appliance off until the winds subside and do not attempt to re-ignite the appliance until it has completely cooled down.

When it has cooled down, before attempting to ignite the appliance remove the catalyser and examine the base of the pot to make sure that there is no oil left in the pot, if there are signs of oil in the pot do not attempt to ignite the appliance until it has been completely dried out.

FIRE

Fire can be caused by a variety of potential danger points and because of the space limitation on boats; this risk is ever present and must be adequately assessed.

The main danger is the effects of heat from the stove on combustible materials and boat occupants.

Make sure that all combustibles are adequately protected from the effects of heat radiation.

Appliances must stand on a fireproof base of minimum thickness 30mm or a purpose made stand.

Floors in front of the stove must have suitable fire protection.

Built in stove heat shields should not be removed under any circumstances.

BURNS

During normal, day-to-day use, many parts of the stove, pipe work, and chimney will become too hot to touch.

Hot surfaces must be adequately protected to prevent anyone falling on to, or touching them.

Suitable fireguards for the appliance and chimney must be fitted.

Fireguards must comply with BS6539.

Always use heatproof gloves when working on or near to a hot stove.

CLEARANCES FROM COMBUSTIBLES

The appliances must be fitted in line with the distances specified in the tables.

All hearths and fireplaces must be made from non-combustible materials and adequately designed for the job.

CLEARANCES FROM COMBUSTIBLES-FLUE PIPES

Flue pipes must be fitted in line with the distances specified in the table and must be suitable for the individual application.

Any combustible materials within the specified distances from the appliances must be protected by a suitable heat shield.

Protection can be gained by the use of -:

- Sheet metal heat shields and spacers.
- Heat resistant boards such as TAC board.
Combustible materials can be-:
- Wooden furniture.
- Curtains.
- Wooden panels or frames adjacent to the flue pipe or where it passes through the deck of the boat.
- Carpet or flooring close to the stove.
- Items near to the stove, which could fall onto it and ignite, should the boat suffer a slight impact or collision.

VENTILATION.

Ventilation plays a vital role in the fitting and sighting of any stove.

The provision of ventilation for these appliances is adequately covered by the requirements of the boat safety scheme.

25cm sq. minimum permanent ventilation, directly to outside air, must be provided.

FLOODED VAPOURIZING BURNER POTS.

When attempting to light any of the appliances, make sure that the pot is not flooded with oil by looking into the base of the burner.

If it is flooded remove the excess oil.

Never try to relight a hot stove; wait until it has cooled down.

Hot oil vapour is explosive.

Never try to light a flooded pot.

SECURELY FIX THE APPLIANCE

The stove must be securely fastened down so that it can resist impact or collision and it must be level in both directions.

Level the stove in both directions when the vessel is midway between its maximum and minimum trim conditions.

Bubble appliances must not be fitted if the maximum angle of trim exceeds 0.75 deg forward to aft or port to starboard.

Only suitably qualified persons can install unvented plumbing systems.

A suitable and serviceable fire extinguisher should always be readily accessible.

3. CHIMNEY

This is the one of the most interesting problems the installer has to deal with and as the chimney affects most aspects of running the stove, we take time here to list the following information for your consideration.

The power, (*suck or vacuum the chimney can develop*) depends upon the following-:

THE HEIGHT.

THE DIAMETER.

THE TEMPERATURE OF THE GASSES IN IT.

THE RESISTANCE OF THE INNER SURFACE OF THE FLUE PIPE OR PIPES.

THE TYPE OF TERMINAL.

THE PREVAILING ATMOSPHERIC CONDITIONS.

It is obvious that on a boat all the above elements are in short supply.

Normally, we have low flues which are small in diameter and generally not very well insulated, coupled with all these problems we have another one, which is that the boat moves across constantly changing surroundings, through locks, into headwinds and crosswinds, all creating major opportunity for down draughting to occur.

Any bend in any part of the chimney or roughness on the internal chimney wall will slow down the velocity of rising gases and reduce the effectiveness of the chimney.

Any slight reduction in the flue gas temperature will reduce the chimney vacuum or pull, hence when the stove is slowed down for all night burning, as the flue gas cools down the chimney vacuum reduces and as the chimney vacuum drops, the stove may well start to burn sooty. This problem is highlighted even more during very cold weather when the chimney can cool down even faster. In these situations careful attention to servicing and low fire setting is essential.

THE CHIMNEY RULES.

1. Always use a top outlet for flue pipe take off.
2. Always try to get the stove as low as possible in the boat, this will allow installation of maximum length flue pipe.
3. Clean or have the chimney cleaned regularly. (Frequency depends upon type of fuel and length of time used).

4. FUEL SUPPLY.

There are several problems relating to diesel fuel supply, which need be adequately addressed.

WAXING

Cold weather waxing or thickening alters the flow characteristics of diesel.

An adequate fuel feed supply can turn into an inadequate one when the temperature starts to fall.

The worst scenario is fuel feed pipe 50-60 feet long in 8mm dia pipe.

The best-case scenario is a fuel pipe 4 feet long in 10mm dia with insulated lagging.

AIR LOCKS

Air lock in oil feed pipe work must be avoided.

The pipe work must slope down to the appliance and be clipped level at 500mm intervals to prevent sagging.

Any rises in the pipe work will cause air locks on commissioning and after future oil run out situations, if it is not possible to run the pipe work in a steady slope then where changes occur a vertical venting leg should be fitted.

TRIM

Bubble appliances must not be fitted if the maximum angle of trim exceeds 0.75 deg forward to aft or port to starboard.

Level the stove in both directions when the vessel is midway between its maximum and minimum trim conditions.

A minimum pressure head of 254mm (10") is required.

This head is measured from the base of the oil tank to the top of the oil control valve. In some cases this head can be affected by the ballast or trim of the boat.

Take great care to try out all the different ballast and trim possibilities to make sure that adequate oil feed is always available at the outlet end of the fuel pipe before it enters the oil control valve at the stove.

TANK

If the stove is fitted at the bow of the boat, a bow tank is recommended.

The tank should comply with the requirements of the boat safety scheme and have:-

- A conveniently sized filler
- A means of venting.
- A conveniently located, easily visible, contents gauge.
- An isolation valve
- An easily replaceable cartridge filter.
- A suitable and substantial water trap

Do not use glass filter bowls, they are not acceptable under the boat safety scheme.

Make sure that your fuel supplier supplies you with appropriate fuel for wintertime running.

OIL LINE

The oil feed line starts after the fuel filter and proceeds to the point of entry, which is where the oil line goes into the cab or saloon of the boat.

The diameter of the oil line is dependent upon the length of run. See 3-2 on waxing and make sure that you have suitably sized compression fittings available.

At this point it is necessary to fit a 60 DEG C, remote sensing fire valve, designed to shut off the oil supply, should a fire occur near to the stove.

If the bubble stove is fitted up to the first bulkhead it will be necessary to fit the isolation valve outside the cabin or saloon of the boat. 5. Make sure that you have purged the oil feed line of all air and there is a steady and constant flow of oil available at the inlet to the oil valve. Make sure that all or any oil isolation devices are turned to the on position. Remember that the oil valve needs a min head of 300mm for gravity feed. When feeding from rear tanks with appliances fitted forward always be aware of the forward - aft trim of the vessel.

Do not use syphonic oil feeds to Bubble Appliances, oil should be fed by gravity or pumped via an appropriate pressure pump = head pressure less than 99mbar.

WATER CONTAMINATION

Because of the high risk of fuel contamination with water, we strongly recommend the fitting of a **high volume water trap**, in the oil supply line.

REMOTE SENSING FIREVALVES

There are two situations where a remote sensing firevalve should be fitted.

1. For fire protection fit a 60 deg C valve.
2. For over boil protection fit an additional 90 deg C valve.

For fire protection a remote sensing fire valve should be fitted as detailed in fig 3.

Run the capillary tube with the oil line up to the stove and carefully fit the sensing phial as follows

B1 Half Pod, B1 Oven and B2 at a low level fitted on two 15mm pipe clips.

Corner Stove and Corner Oven Stove on 15mm pipe clips in front of the drip tray on the fireplace hearth, directly in front of the combustion air restrictor.

Before it is fitted try the fender on the stove to make sure that the fender does not foul the sensing phial.

The sensing phial may be visible through the bottom of the fender, to mask it, paint it with matt black paint available from our sales desk.

When fitting the fire valve make sure that where the capillary and oil line go through the bulkhead in separate sleeved tubes, so that the capillary can be withdrawn separately should it ever need replacing.

For fitting of long oil feed lines which pass through bulkheads and various other parts of the boat it may well be necessary to fit more than one fire valve, especially where the oil line passes through an area where a fire could occur i.e. kitchen area etc.

ISOLATION VALVES.

Two isolation valves are required, one fitted directly into or close to the oil control valve to allow you or the service man to turn the oil off should the need arise, and one fitted directly into the oil tank before the fuel filter.

Always turn off the oil isolation valve serving the appliance before leaving the vessel unattended.

SLEEVING.

Where the oil line goes through the boat superstructure a suitable bulkhead fitting must be used.

OVERBOIL OR OVERHEAT PROTECTION OF THE APPLIANCE.

Where appliances are not fitted with an automatic thermostat an additional 90 DEG C, remote sensing

fire valve must be fitted directly in front of the oil control valve and the sensor from this valve has to be attached to the water jacket or the hot outlet pipe from the boiler.

The valve is calibrated to shut the oil supply down should the water temperature exceed 90 Deg C.

There is a re set button on the remote sensing fire valve which needs to be pressed in to re set the valve after it has tripped off.

4A LIGHTING & COMMISSIONING

A relevant oil control valve catalogue is supplied with each appliance and details of high and low fire adjusting screws are illustrated.

On the Toby valve the low fire screw is clearly visible as per TOBY MANUAL FIG 2

Before trying to light the burner in cold weather it is advisable to pre heat the flue pipe before lighting.

There are two different types of burner fitted to Bubble appliances.

The FB style burner fitted to the **B1 Half Pod, B1 Pie Pod and B2.**

The Socomef burner fitted to the **Corner Stove, Corner Oven Stove** and the **Back Cabin Cooker see sec 4B for lighting Socomef burners.**

1. LIGHTING B1 HALF POD, B1 PIE POD AND B2

When attempting to light the stove these are the rules, which must be followed.

1. Always make sure that the pot is **not** flooded with oil by looking down into the base of the pot.
2. Never try to light the stove if it is flooded with oil.
3. Always check that oil has not leaked from the appliance.
4. Do not light the stove and leave it unattended until it is settled down and stabilized into constant blue flame combustion on low fire. (This could take 10 to 20 minutes.)

On first light up it is advisable to warm the flue pipe up to try and create chimney draft.

Two Ways to Light the Stove

1. Through the lighting port B1 and B2 appliances only,
or
2. Directly into the base of the pot by removing the catalyser.

Lighting into the base of the Pot

On the first light up you may find this option better, as it is possible to see the oil trickle in to the pot more easily.

Use a heatproof glove when putting the catalysers back into the pot and it is important to replace them quickly whilst the flame is small.

Make sure that the oil is turned off.

Open the front door.

Remove the optional coal kit if fitted.

Remove the catalyser.

Turn the oil on and allow a small pool of oil to flow into the pot about the size of a small biscuit, **then turn the oil off.**

Note that on first light up it may take a few minutes for the oil to reach the pot as it has to fill the pipework before reaching the pot, take care not to allow excess oil to flow into the pot.

Light a small piece of firelighter and drop it into the oil, allow a few seconds for it to get going and then replace the catalyser and coal kit if fitted, and close the door.

Wait for approx. 1 minute until the pool of oil is alight and then **turn the oil on** to minimum setting no 1.

Watch the appliance for a few minutes and you will see the flame establish and settle down into blue flame combustion.

Allow the burner to run for a further 10 minutes before turning the appliance up to the higher settings.

If at any time during the ignition process large amounts of flame can be seen, turn the oil off immediately and wait until the flames die down before putting the oil on again at minimum setting.

Manual Lighting through the Lighting Port B1 and B2 appliances.

Check that the isolation valve is turned on.

Open the front door.

Remove the front apron on B1 Half Pod and B1 pie Pod.

Remove the lighting port plug by pulling it out of its tubular socket.

Turn the oil on to the first position via the flow control knob and allow a small pool of oil to flow into the pot about the size of a small biscuit.

Turn the oil off.

Cut a small piece of firelighter and stab it onto the spike.

Light it and push it into the lighting port tube, let the firelighter drop off the spike into the bottom of the pot.

Replace the lighting port plug back into the tube.

Close the front door.

Turn the fuel flow on again at the lowest setting

Watch the appliance for a few minutes until it settles down into blue flame combustion.

Allow the burner to run for a further 10 minutes before turning the appliance up to the higher settings.

If at any time during the ignition process large amounts of flame can be seen, turn the oil off immediately and wait until they die down before putting the oil on again.

Note there may be the occasional growl or audible vibration whilst the burner settles down into blue flame combustion.

COMMISSIONING THE HIGH & LOW FIRE, CHRYSTAL SERIES

Used in B1 Half Pod, B1 Pie Pod and B2

When the burner has established good blue flame combustion turn it up to half output. (Setting 3 on the fuel flow control knob) and let it stabilize.

Allow at least half an hour for the chimney to warm up thoroughly before making any adjustments to the high or low fire screws.

Turn the stove down onto minimum firing rate and let it stabilize.

After stabilization there should be a dull red glow in the lower catalyser with wispy blue flames flicking into and just over it.

If the flame falls into a dirty rolling yellow flame and the catalyser is not dull red then the low fire will need to be increased until it can support the required blue flame combustion.

To increase the low fire oil flow, screw the adjusting screw out by quarter turn increments.

When you are happy with the low fire, set the high fire.

Turn the oil flow knob up to setting 4, let the flame stabilize, and look at it, if it is stable and blue, turn it up slowly using the control knob, letting it stabilize after each movement, if the flame starts to go yellow with long flame combustion, it is running fuel rich and

the high fire screw needs adjusting to reduce the flow of oil. (Screw the adjuster screw in to reduce the high fire oil flow.)

Before adjusting the high fire screw, turn the flame down and let it stabilize in blue flame combustion, adjust the high fire screw by half a turn in and try turning the fuel flow up, if it is still fuel rich repeat the process until the high fire flame is running blue with just flicks of yellow in the tips.

To see a bubble stove running correctly see the following link

<https://www.youtube.com/watch?v=UqdQLFp3HkQ>

4B LIGHTING & COMMISSIONING THE BURNER SOCOMEF SERIES

1. LIGHTING CORNER STOVE, CORNER POD AND BACK CABIN COOKER.

When attempting to light the stove these are the rules, which must be followed.

1. Always make sure that the pot is not flooded with oil by looking down into the base of the pot.
2. Never try to light the stove if it is flooded with oil.
3. Always check that oil has not leaked from the appliance.
4. Do not light the stove and leave it unattended until it is settled down and stabilized into constant blue flame combustion on low fire. (This could take 10 to 20 minutes.)
5. Make sure that you have purged the oil feed line of all air and there is a steady and constant flow of oil available at the inlet to the oil valve. Make sure that all or any oil isolation devices are turned to the on position. Remember that the oil valve needs a min head of 300mm for gravity feed. When feeding from rear tanks with appliances fitted forward always be aware of the forward - aft trim of the vessel.
6. Do not use syphonic oil feeds to Bubble Appliances, oil should be fed by gravity or pumped via an appropriate pressure pump = head pressure less than 99mbar.

On first light up it is advisable to warm the flue pipe up to try and create chimney draft.

Lighting the Stove

Lighting the stove takes a little time and patience; the following procedure should be adopted.

In the case of the Corner appliances, open the front door and in the case of the Back Cabin Cooker remove the hot plate and top baffle to gain access to the

burner, note that the back cabin cooker has a lighting port fitted behind the lower ash pit door.

Remove the coal kit if it has been supplied with the stove.

Lift the inner mesh catalyser from the burner.



Look into the bottom of the pot and turn the oil on at full rate, allow oil to flow into the bottom of the pot to form a pool about the size of a small digestive biscuit and then turn the oil off.

Note that on first light up it may take a few minutes for the oil to reach the pot as it has to fill the pipework before reaching the pot.

Do not allow any depth of oil to build up.

Light a small piece of firelighter (about the size of a pineapple chunk) and place it into the centre of the oil pool.

Replace the mesh catalyser and the coal kit, if fitted and then leave the door slightly open whilst the firelighter gets the oil going.

After 30 to 40 seconds, you will notice the flame start to establish itself and spread around the bottom of the pot.

When this occurs, close the door or replace the baffle and top plate and then turn the oil on to its minimum setting.

After two or three minutes the flame should slowly change from yellow into blue flame combustion and settle down to a steady burn.

Note there may be the occasional growl or audible vibration whilst the burner settles down into blue flame combustion.

Allow the burner 10 - 15 minutes to stabilise and the increase the flow of oil as required, moving by one increment of the dial only.

Do not leave the appliance unattended during the lighting and stabilising procedure.

COMMISSIONING THE HIGH AND LOW FIRE SOCOMEF BURNERS.

Corner Stove, Corner Pod and Back Cabin Cooker.

Note that Back cabin Cookers are pre commissioned at the factory and do not need adjusting.

A relevant oil control valve catalogue is supplied with each appliance and details of high and low fire adjusting screws are illustrated.

On the Toby valve the low fire screw is clearly visible as per TOBY MANUAL FIG 2

When the burner has established good blue flame combustion turn it up to half output. (Setting 3 on the fuel flow control knob) and let it stabilize for a minute. Allow at least half an hour for the chimney to warm up thoroughly before making any adjustments to the high or low fire screws.

Turn the stove down onto minimum firing rate and again let it stabilize.

After stabilization there should be a dull red glow in the catalyser with wispy blue flames flickering just over the top of it, approximately level with the top of the pot.

If the flame falls into a dirty rolling yellow flame and the catalyser is not dull red then the low fire will need to be increased until the burner can support the required blue flame combustion.

When you are happy with the low fire, set the high fire.

Turn the oil flow knob up to setting 4, let the flame stabilize, and look at it, if it is stable and blue, turn it up slowly using the control knob, letting it stabilize after each movement, if the flame starts to go yellow with long flame combustion, it is running fuel rich and the high fire screw needs adjusting to reduce the flow of oil. (Screw the adjuster screw in to reduce the high fire oil flow.)

Before adjusting the high fire screw, turn the flame down and let it stabilize in blue flame combustion, adjust the high fire screw by half a turn in and try turning the fuel flow up, if it is still fuel rich repeat the process until the high fire flame is running blue with flicks of yellow in the tips.

On the Socomef pot, the high fire flame will be set approx. 40mm above the top of the pot.

NOTE THAT THIS PROCEDURE WILL NOT BE POSSIBLE IF THE CHIMNEY RULES HAVE NOT BEEN ADHERED TO.

THE HIGH FIRE SETTING WILL HAVE TO BE ADJUSTED IN LINE WITH THE AVAILABLE GENERATED CHIMNEY VACUUM IE

THE FLUE PIPE MUST BE A MINIMUM OF 1.8 METERS HIGH FOR LOW FIRE AND 2.1 METERS FOR HIGH FIRE.

INSTALLING ENGINEERS SHOULD NOT LEAVE THE APPLIANCE UNDER THE CONTROL OF THE CUSTOMER UNLESS THE APPLIANCE HAS BEEN CORRECTLY COMMISSIONED.

TO SEE HOW THE BURNER SHOULD OPERATE COMMISSIONING AND INSTALLING ENGINEERS SHOULD VISIT

<https://www.youtube.com/watch?v=UqdQLFp3HkQ>

This video shows a stove running from low to high fire and back to low fire. Note that this video is filmed on a normal house chimney and so it may not be possible to get exactly the same conditions on a typical boat flue as the fuel air ratio will not be exactly the same, hence the need for fine tuning the oil flow to the chimney air flow capability.

5. FIREPLACE.

Unless one is built into the appliance, always fit appliances on a suitable drip tray.

The possibility of oil drops leaking from the stove must be considered; a suitable oil drip tray must be fitted and designed in such a way, as it will contain any oil leaks or drips.

Normally the tray will cover the footprint of the stove, the oil valve and isolation device.

It will be oil tight and have a vertical up stand of at least 30mm. This should give a minimum containment volume of 2 litres.

It will be securely fastened down to the vessel and the appliance must be securely fastened down to the oil drip tray.

Make sure that drip trays are tested to ensure that they do not leak when filled with oil.

The hearth must be:-

FLAT - SECURE - FIREPROOF AND LEVEL IN BOTH DIRECTIONS.

Use materials, which are easy to keep clean and fireproof such as tiles, asbestolux or vermiculite boarding with a suitable weight resistant liner.

The vertical walls of the fireplace must also be made from fireproof materials.

Use fireproof, rockwool infill behind the fireplace panels to protect any combustible insulation materials

such as spray foam.

6. DISTANCES FROM COMBUSTIBLES (APPLIANCES)

Stove Type	ABOVE	SIDES.	BACK	FRONT	HEARTH Non Combustible Material
B1 HALF POD and OVEN VERSION	500	300	150 FROM HEAT SHIELD	300 to allow door opening.	30MM THICK x 100 projection at the front and sides
BOAT B2	600	300	150 FROM HEAT SHIELD	300 to allow door opening.	30MM THICK x 100 projection at the front and sides
CORNER and OVEN VERSION	500	75	100 FROM HEAT SHIELD	300 to allow door opening.	30MM THICK x 100 projection at the front.
BACK CABIN COOKER	500	150	100 FROM HEAT SHIELD	300 to allow door opening.	25MM THICK x 150 projection at sides

7. DISTANCES FROM NON COMBUSTIBLES (APPLIANCES)

Stove Type	ABOVE	SIDES.	BACK	FRONT	HEARTH Non Combustible Material
B1 HALF POD and OVEN VERSION	300	150	150 FROM HEAT SHIELD	300 to allow door opening.	30MM THICK x 100 projection at the front and sides.
BOAT B2	300	150	150 FROM HEAT SHIELD	300 to allow door opening.	30MM THICK x 100 projection at the front and sides.
CORNER and OVEN VERSION	200	150	25 FROM HEAT SHIELD	300 to allow door opening.	30MM THICK x 100 projection at the front and sides.
BACK CABIN COOKER	500	75	50 FROM HEAT SHIELD	300 to allow door opening.	25MM THICK x 75 projection at sides

Note that the back cabin cooker can have the oil control valve fitted to the rear or the left hand side in each case the positioning of the valve will affect the fireplace and spacing considerations, see sizes of cooker to establish requirements.

8. DISTANCES FROM COMBUSTIBLES (FLUE PIPES)

For all appliances-:

1. Single skin flue pipes. Horizontal Distance = 50mm **when fitted within the deck flange** at the top of the chimney system, protected by the fire stop spacer.
2. Single skin flue pipes. Horizontal Distance = 150mm **when exposed in the saloon or living space.**
3. Twin Wall Insulated flue pipes. Horizontal Distance = 30 mm for insulated flue pipe systems.

9. ILLUSTRATIONS

FIG 1. STOVE DISTANCE FROM COMBUSTIBLES

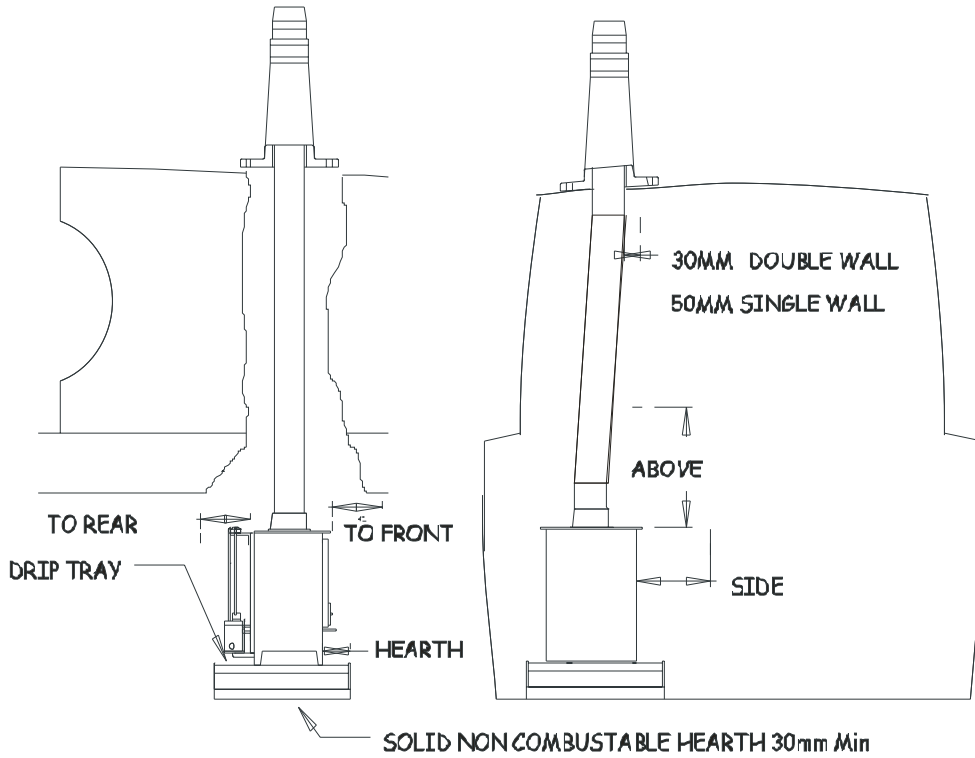

FIG 2 BUBBLE MK1 FABRICATED DECK FLANGE LAYOUT

Note that there is mk3 system which is now available and detailed on our web site.

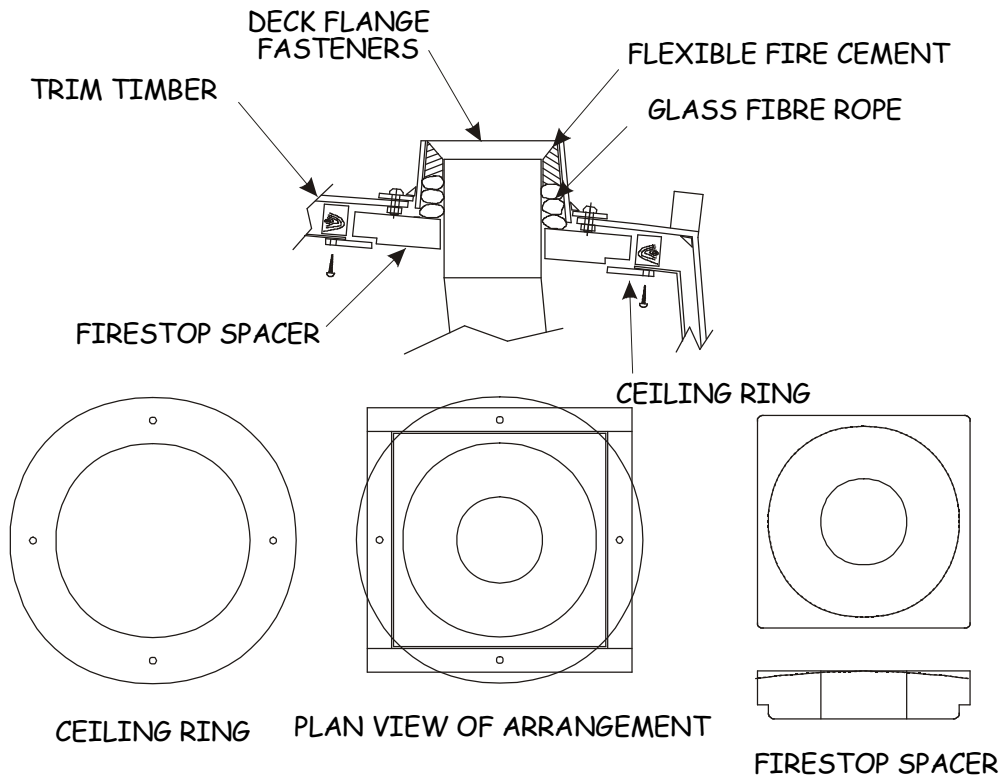
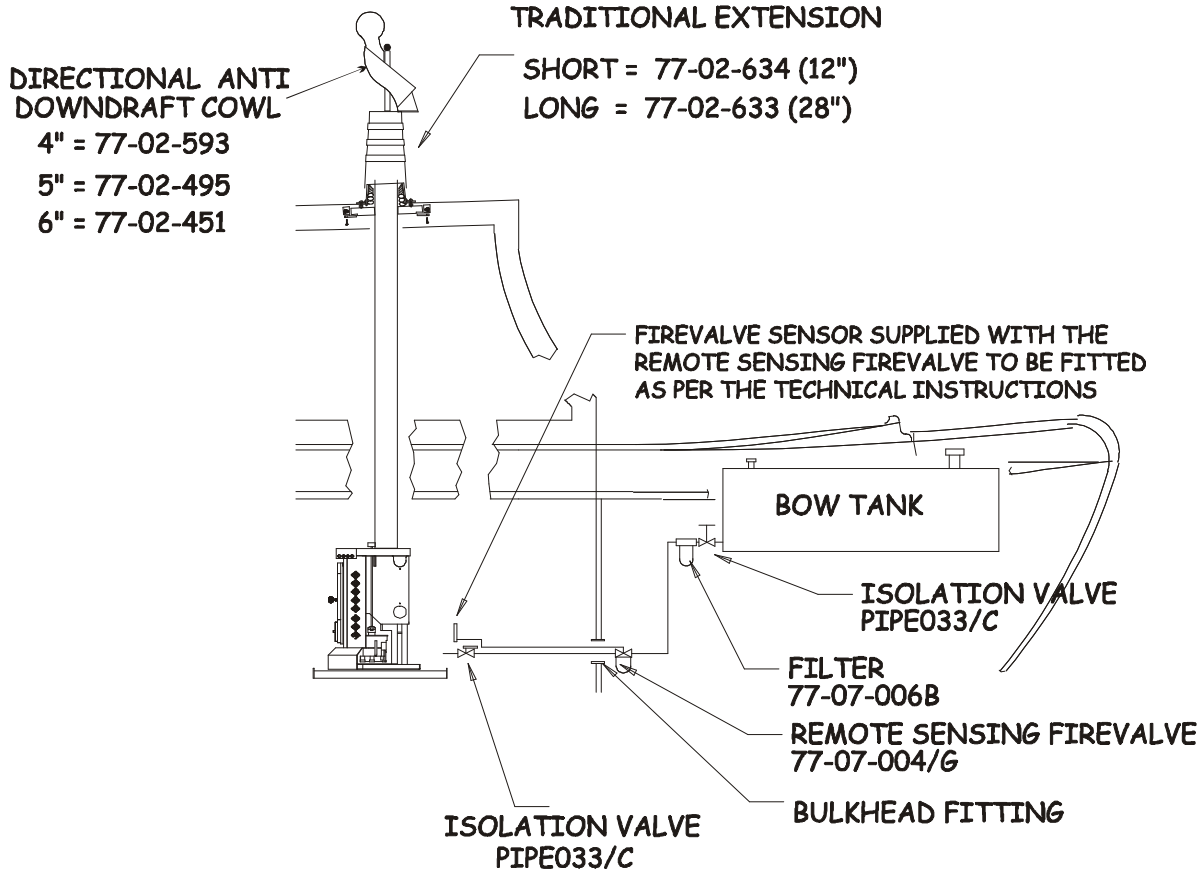

FIG 3 TYPICAL OIL FEED LAYOUT



COPYRIGHT HARWORTH HEATING LTD 080800

FIG 4 TYPICAL PUMING LAYOUTS

Drq 1

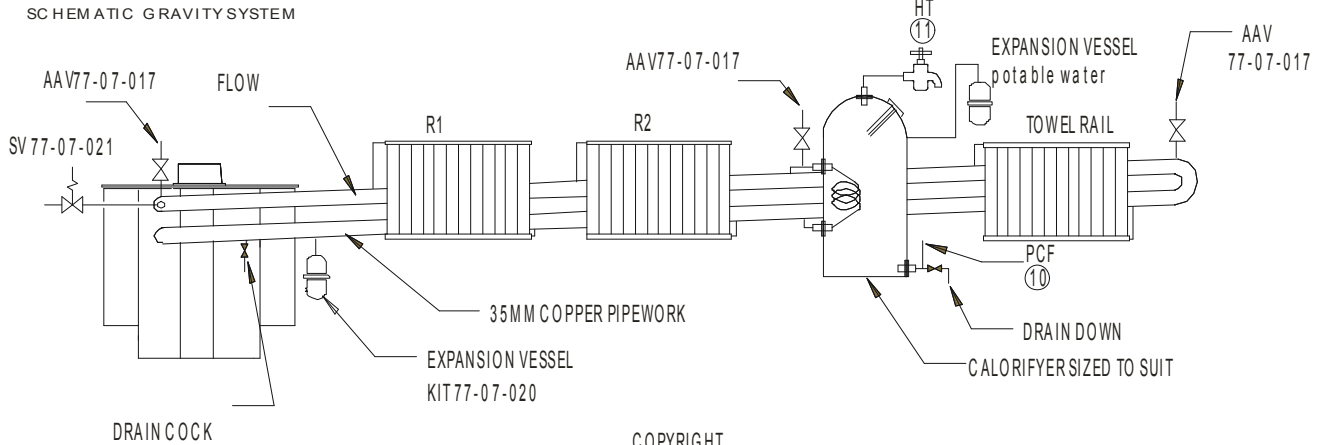

COPYRIGHT BUBBLE PRODUCTS 2013

Drg 2

SCHEMATIC PUMPED SYSTEM ISS 2 OF 28-10-17

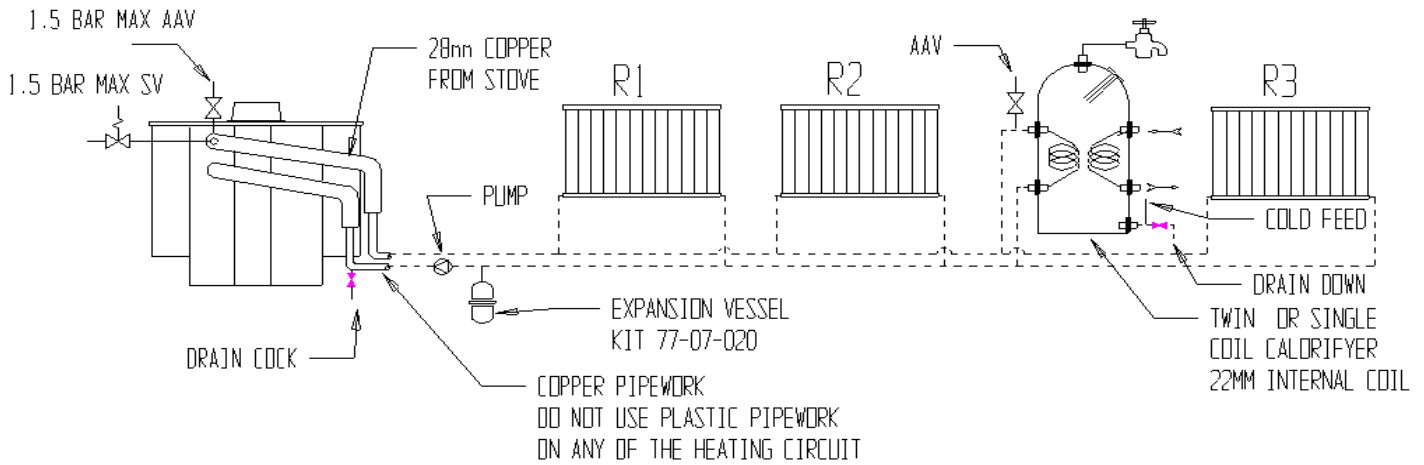

Drg 3

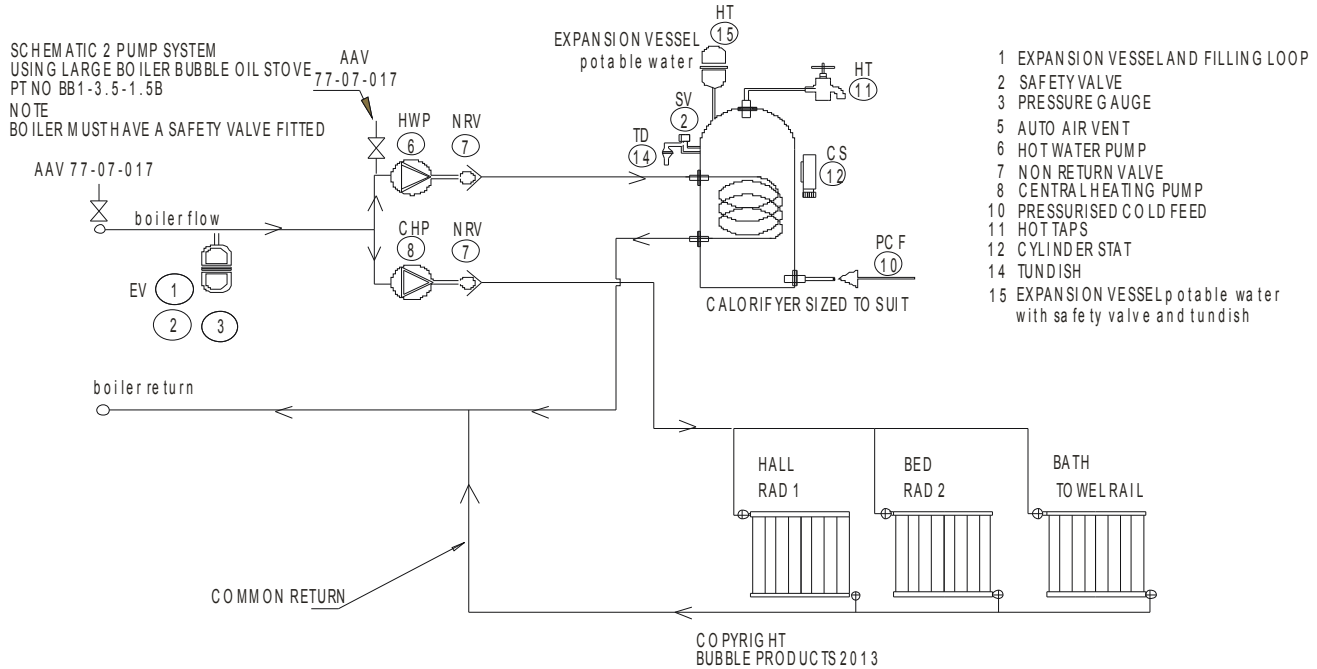

10. STOVE DIMENSIONS

10-1 BB1 HALF POD AND PIE POD DIMENSIONS

Note that the B1 Pie Pod has the same footprint dimensions but the vertical height is 830mm.

**B1 HALF OIL POD OF 12-02-15
OVERALL DIMENSIONS
BOILER AND NON BOILER VERSIONS**

**.WEIGHT 35 KG NON BOILER
.WEIGHT 45 KG SMALL BOILER
.WEIGHT 50 KG LARGE BOILER**

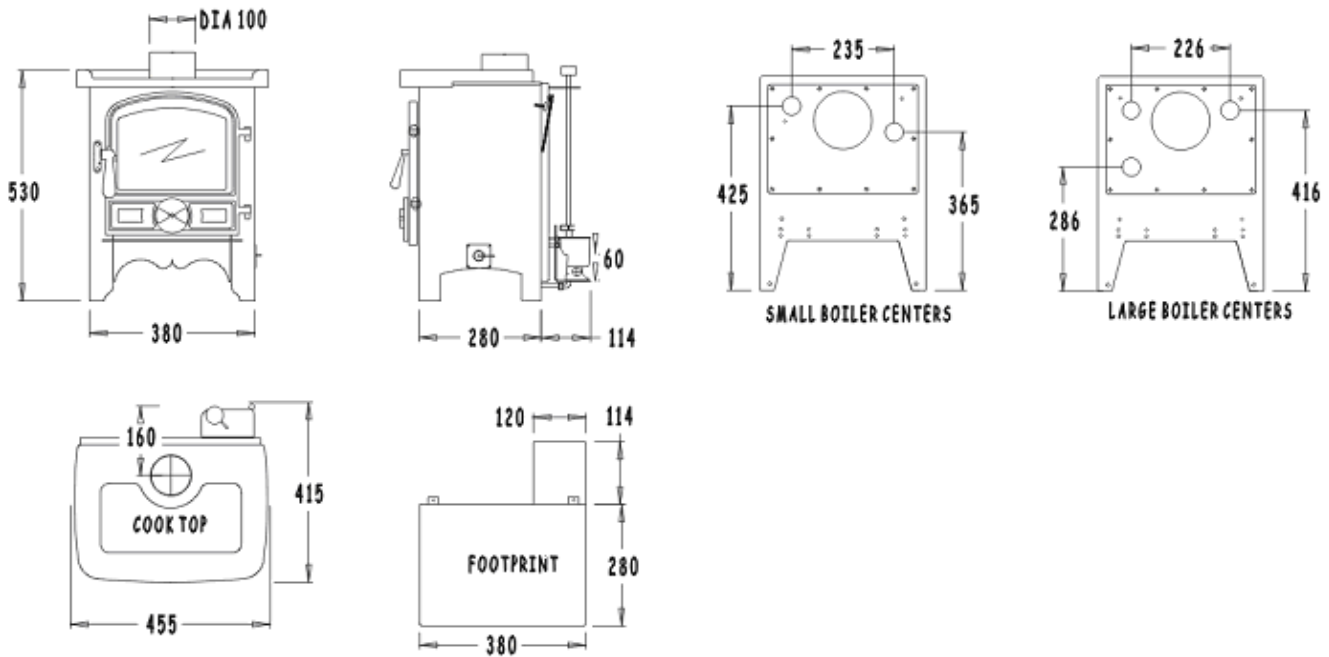

10-2 CORNER STOVE AND CORNER PIE POD DIMENSIONS

Note that the Corner Pie Pod has the same footprint dimensions but the vertical height is 840mm.

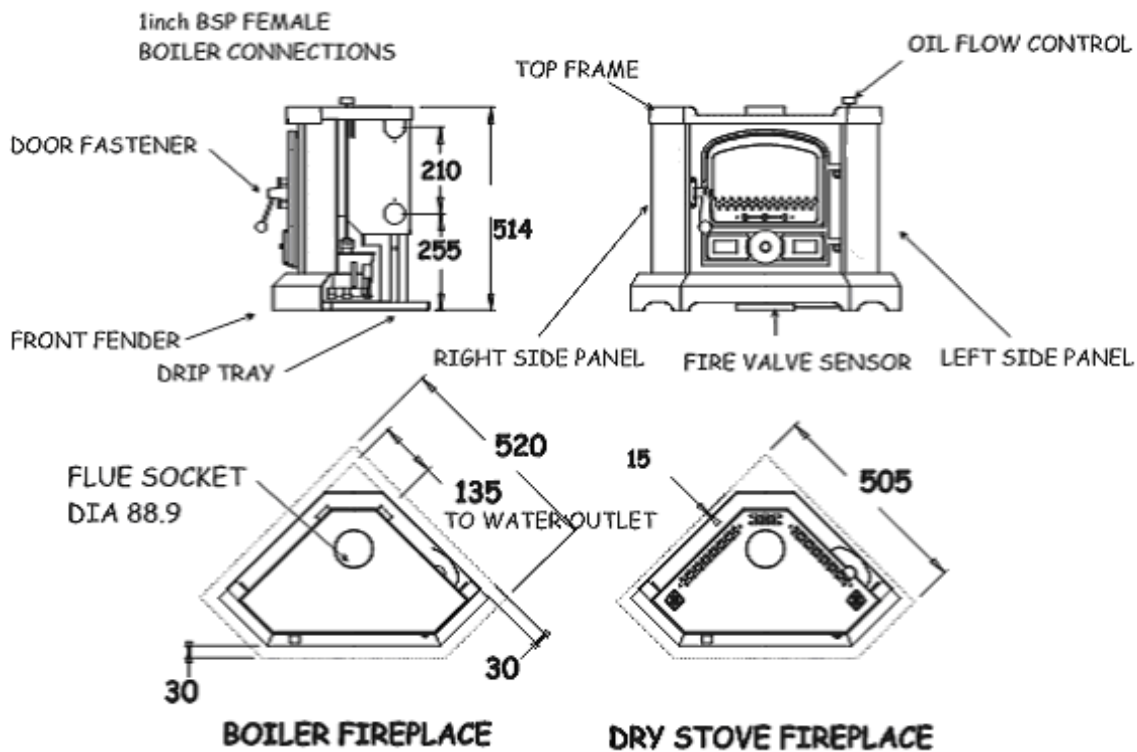

10-3 B2 STOVE DIMENSIONS

Note that the B2 Pie Pod has the same footprint dimensions but the vertical height is 830mm.

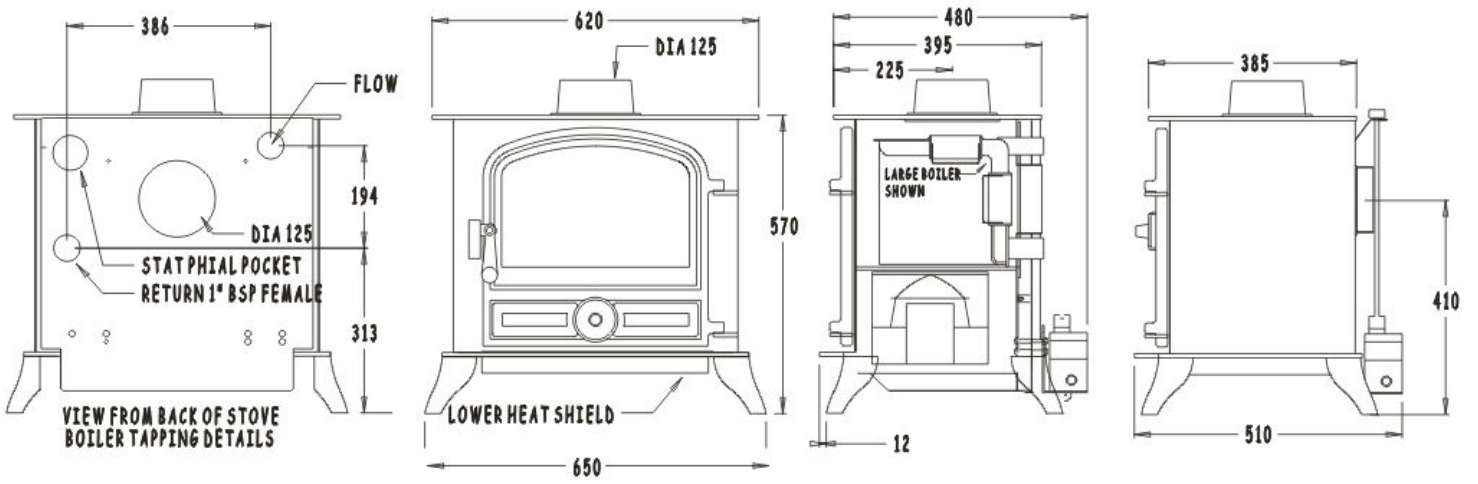

10-4 BACK CABIN COOKER DIMENSIONS

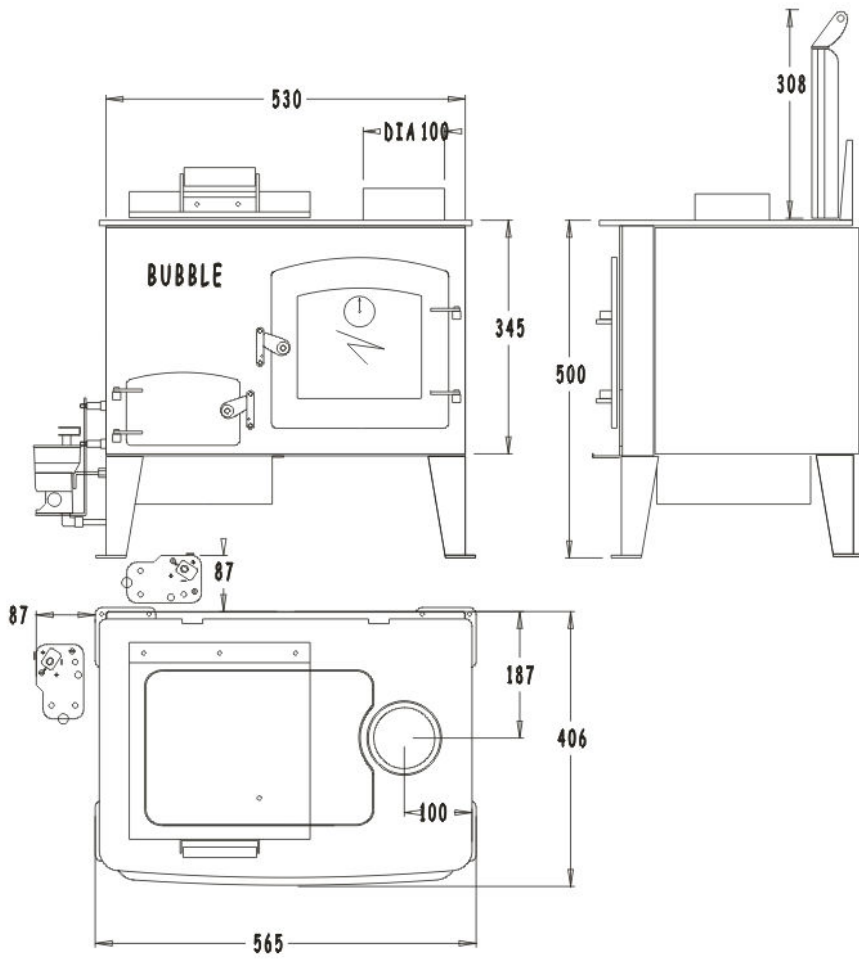

11. OIL CONSUMPTION RATES

		MAX HEAT OUTPUT TO WATER	MAX HEAT OUTPUT TO SPACE	MINIMUM OIL FLOW CC'S PER MIN	MAXIMUM OIL FLOW CC'S PER MINUTE
--	--	--------------------------	--------------------------	-------------------------------	----------------------------------

B1 HALF POD & OVEN DERIVATIVE					
Free Standing	From 1.6kW to 5kW		5kW	4 = (1.6kW)	12 = (5kW)
Free Standing	From 1.6kW to 5kW	2kW	3kW	4 = (1.6kW)	12 = (5kW)
Free Standing	From 1.6kW to 6kW	5kW	2kW	4 = (1.6kW)	13 = (6kW)

CORNER STOVE & OVEN DERIVATIVE					
Free Standing	From 1kW to 4kW		4kW	3 = (1kW)	10 = (4kW)
Free Standing	From 1kW to 4kW	3kW	1kW	3 = (1kW)	10 = (4kW)

BUBBLE 2					
Free Standing	From 1.6kW to 5kW		5kW	4 = (1.6kW)	13 = (5kW)
Free Standing	From 1.6kW to 8kW		8kW	4 = (1.6kW)	16 = (8kW)
Free Standing	From 1.6kW to 8kW	3kW	5kW	4 = (1.6kW)	16 = (8kW)
Free Standing	From 1.6kW to 8kW	9kW	2kW	4 = (1.6kW)	22 = (11kW)

BACK CABIN COOKER					
Free Standing	From 1.6kW to 5kW		3kW	4 = (1.6kW)	7 = (3kW)
Free Standing	From 1.6kW to 5kW	1kW	2kW	4 = (1.6kW)	7 = (3kW)

© HARWORTH HEATING LTD 30.6.98

This publication may not be copied by any means, without written permission from the authors.

These products are subject to continuous development and improvement and it is consequently acknowledged that due to this process there may be some omissions and errors.

This publication is intended only to assist the reader in the use of this product and therefore Harworth Heating Ltd shall not be liable for any loss or damage whatsoever arising from the use of any information, error or omission found in this publication.

The appliances mentioned in this publication can only be installed and serviced by approved personnel.

Approved personnel means that they must HAVE BEEN SUITABLY TRAINED, if there are any

reliability issues reported back to **Harworth Heating** or **Bubble Products**, the installing engineer will be responsible for carrying out any rectification work.

For details of suitable training courses contact: - www.oftec.org

12. NORMATIVE REFERENCES

Boat installation work comes under the control of: -
The Boat Safety Scheme.

This scheme provides statutory requirements and associated EN / BS Standards for most aspects of installation work on boats.

Further information and a copy of the requirements can be obtained from:-

www.boatsafetyscheme.com

Where guidance for oil fired appliances is not readily available from the Boat safety Scheme publication, we then point out a list of standards which pertain to domestic installations and which are generally covered by the latest version of the English Building Regulations Doc J.

When read in conjunction with:-

1. Our installation instructions.
2. The Boat Safety Scheme rules.
3. The other standards detailed, enough information should be provided to allow for a safe installation.

BS 5440	Flues.
BS 6999	Flues
BS 7840	Fuel Hoses.
BS EN1057	Copper Tubes.
BS1344 Part 3 1988 ISO8290 1987	Flues.
BS EN 1443:2003	Chimneys - General requirements.
BS EN1856 part 1 replacing BS 4543	Flues.
BS EN1856 part 2 & BS 715 1993	Flues.
BS 1945: 1971	Stove door
BS EN 10296-1	Steel tubes
BS ISO 10088:2001	
BS EN ISO 9094-2003	
BS EN 10297-1	Steel tubes
BS EN 13384-1	Chimneys
BS EN 10088-1:2005	Stainless steels - Part 1: List of stainless steels

INSTALLATION & GENERAL INSTRUCTIONS



Silent Simplicity just for you!

MARINE OIL STOVES ©

ISSUE 15 @ 22-06-18

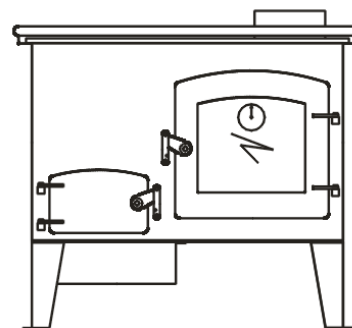
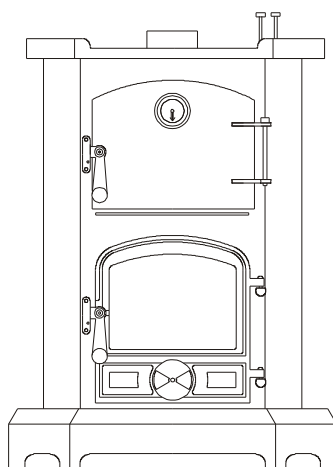
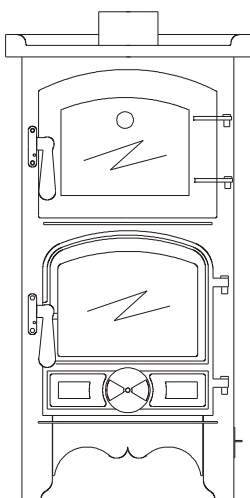
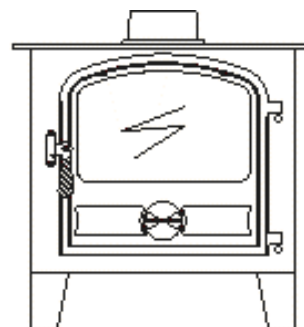
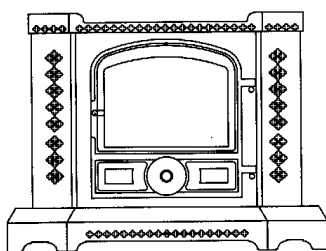
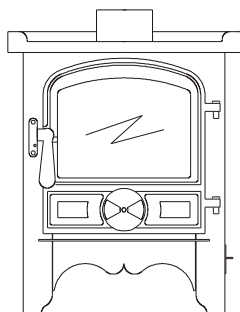

www.harworthheating.co.uk

INDEX

1. BEFORE STARTING THE JOB.	3
FITTING OPTIONS.	3
ABOUT THE APPLIANCES	3
2. SAFETY.	4
FUMES	4
FIRE	4
BURNS	4
CLEARANCES FROM COMBUSTIBLES	4
CLEARANCES FROM COMBUSTIBLES-FLUE PIPES	5
VENTILATION.	5
FLOODED VAPOURIZING BURNER POTS.	5
SECURELY FIX THE APPLIANCE	5
3. CHIMNEY	5
THE HEIGHT.	5
THE DIAMETER.	5
THE TEMPERATURE OF THE GASSES IN IT.	5
THE RESISTANCE OF THE INNER SURFACE OF THE FLUE PIPE OR PIPES.	5
THE TYPE OF TERMINAL.	5
THE PREVAILING ATMOSPHERIC CONDITIONS.	5
THE CHIMNEY RULES.	6
4. FUEL SUPPLY.	6
WAXING	6
AIR LOCKS	6
TRIM	6
TANK	6
OIL LINE	6
WATER CONTAMINATION	6
REMOTE SENSING FIREVALVES	7
ISOLATION VALVES.	7
SLEEVING.	7
OVERBOIL OR OVERHEAT PROTECTION OF THE APPLIANCE.	7
4A LIGHTING & COMMISSIONING	7
1. LIGHTING B1 HALF POD, B1 PIE POD AND B2	7
COMMISSIONING THE HIGH & LOW FIRE, CHRYSAL SERIES	8
4B LIGHTING & COMMISSIONING THE BURNER SOCOMEF SERIES	9
1. LIGHTING CORNER STOVE, CORNER POD AND BACK CABIN COOKER.	9
COMMISSIONING THE HIGH AND LOW FIRE SOCOMEF BURNERS.	10
5. FIREPLACE.	10
6. DISTANCES FROM COMBUSTIBLES (APPLIANCES)	11
7. DISTANCES FROM NON COMBUSTIBLES (APPLIANCES)	11
8. DISTANCES FROM COMBUSTIBLES (FLUE PIPES)	11
9. ILLUSTRATIONS	12
FIG 1. STOVE DISTANCE FROM COMBUSTIBLES	12
FIG 2 BUBBLE MK1 FABRICATED DECK FLANGE LAYOUT	12
FIG 3 TYPICAL OIL FEED LAYOUT	13
FIG 4 TYPICAL PUMBING LAYOUTS	13
10. STOVE DIMENSIONS	14
10-1 BB1 HALF POD AND PIE POD DIMENSIONS	14
10-2 CORNER STOVE AND CORNER PIE POD DIMENSIONS	15
10-3 B2 STOVE DIMENSIONS	15
10-4 BACK CABIN COOKER DIMENSIONS	16
12. NORMATIVE REFERENCES	18

If you have any difficulties please phone our technical help line on-:

01302 742520 fax 01302 750573

e-mail contact@bubbleproducts.co.uk

<http://www.bubbleproducts.co.uk>

1. BEFORE STARTING THE JOB.

THE FOLLOWING NOTES PROVIDE INFORMATION FOR INSTALLATION OF THE FOLLOWING APPLIANCES.

Boat Bubble No 1 AND HALF POD, Dry Small and Large Boiler Appliances

Boat Bubble No 2 Dry Small and Large Boiler Appliances

Marine Corner Bubble Wet and Dry appliances

Bubble No 1 Cooking Stove plus boiler options.

Corner Cooking Stove plus boiler options.

Back Cabin Oil Fired Cooker.

FITTING OPTIONS.

There are normally two different situations that the installer may be faced with:-

1. A new build installation.

An established boat installation, (which has not had oil stove fitted).

2. A replacement installation, where there has been a solid fuel stove fitted previously.

Each of the situations will present differing problems which will be:-

- Where to locate the stove.
- How to deal with fireplace design.
- Where to locate the oil tank.
- How to get an oil supply to the stove.
- How to fit the chimney.
- How to connect water to the stove.
- How to disconnect and remove the stove, easily.

The new build situation should be the easiest.

The established boat situation will require careful attention to the sighting of the stove in relation to flue positions and existing fittings positions.

In replacement situations it may well be necessary to blank off the existing through roof flue position and cut a fresh one to suit the new location and comply with our instructions on flue design.

ABOUT THE APPLIANCES

Generally described as a space heater or space heater and cooker, which burns diesel oil in a controlled

manner utilizing a chimney to discharge the products of combustion.

The appliance generates heat from burning oil mixed with air in a vaporizing pot located in the bottom of the stove.

Once the appliance has been ignited, oil goes into the pot at a steady and controlled rate via a gravity feed which is metered by the OIL CONTROL VALVE; the oil flow can be controlled from minimum to maximum or any setting in between determined by the set position of the oil flow control knob.

Air is sucked into the pot by the natural action of the negative pressure in the chimney.

To allow the chimney to work correctly it is essential that you have adequate, unrestricted ventilation into the area where the stove is situated.

The amount of oil that can be successfully burned is directly proportional to the amount of air that the chimney can draw into the pot and so to achieve adequate combustion a balanced and appropriate flow of both oil and air is required.

The stove will provide space or combined space and water heating and in some cases cooking as well.

Where cooking and water heating are combined one feature will inevitably effect the other.

There are different versions of each appliance within the total range.

Some of the appliances are supplied as Dry, Small Boiler and Large Boiler versions namely B1 Half Pod, B1 Oven and B2.

Some of the appliances are supplied just as Dry and Large Boiler versions namely Corner Stove and Corner Oven Stove.

The Back Cabin Cooker can be supplied with or without a small boiler for domestic hot water heating only.(1kw)

All of the boilers are high water content and suitable for pumped or gravity systems and pressurised or open vented systems ASSUMING THAT THEY ARE INSTALLED BY SUITABLY QUALIFIED PERSONS.

All the appliances are fitted with a descaling device which should be rotated on a two weekly cycle to descale the oil inlet pipe.

Where applicable, appliances must not be operated with the glass front door opened or cracked, or without the lighting port plug fitted.

Where applicable, the door glass may require light cleaning occasionally depending upon the continuous running time of the stove.

Appliances must be securely bolted down to resist impact or collision and must be level in both directions.

All the appliances are supplied with clamp down brackets except the Back Cabin Cooker which must be fastened down through the foot plates.

The top of the appliances can be used for warming and cooking.

The oven appliances have a comprehensive range of cooking facilities with both oven and hot plate cooking available.

Some appliances can also be supplied with a coal kit, which just like a solid fuel stove, coal effect will only be available when the stove is running at maximum or near maximum performance.

Suitable deck flanges, flue systems and anti-downdraft cowls must be used.

CONTROLS

The output of the stove is regulated by the amount of oil allowed to go into it and this function is controlled by the -:

OIL CONTROL VALVE (O.C.V.), Turning the knob anti clockwise controls the oil flow.

2. SAFETY.

Take care to make sure that all safety and ventilation issues are adequately addressed.

FUMES

Always fit a suitable Smoke and Carbon Monoxide alarm within 1.5meters of the appliance.

Make sure that the function is checked on regular basis. (weekly)

Make sure that the alarm can be heard in the sleeping quarters.

Here are the main causes of fume or smoke to leak from the stove.

- The chimney is blocked.
- There are too many bends in the chimney.
- The above deck chimney extension is not high enough.
- The boat is moored in a position near to high buildings or trees and downdraughting is occurring.
- The chimney or parts of it are not airtight.

- There are unusually strong cross winds.

If down draughting occurs turn the appliance off until the winds subside and do not attempt to re-ignite the appliance until it has completely cooled down.

When it has cooled down, before attempting to ignite the appliance remove the catalyser and examine the base of the pot to make sure that there is no oil left in the pot, if there are signs of oil in the pot do not attempt to ignite the appliance until it has been completely dried out.

FIRE

Fire can be caused by a variety of potential danger points and because of the space limitation on boats; this risk is ever present and must be adequately assessed.

The main danger is the effects of heat from the stove on combustible materials and boat occupants.

Make sure that all combustibles are adequately protected from the effects of heat radiation.

Appliances must stand on a fireproof base of minimum thickness 30mm or a purpose made stand.

Floors in front of the stove must have suitable fire protection.

Built in stove heat shields should not be removed under any circumstances.

BURNS

During normal, day-to-day use, many parts of the stove, pipe work, and chimney will become too hot to touch.

Hot surfaces must be adequately protected to prevent anyone falling on to, or touching them.

Suitable fireguards for the appliance and chimney must be fitted.

Fireguards must comply with BS6539.

Always use heatproof gloves when working on or near to a hot stove.

CLEARANCES FROM COMBUSTIBLES

The appliances must be fitted in line with the distances specified in the tables.

All hearths and fireplaces must be made from non-combustible materials and adequately designed for the job.

CLEARANCES FROM COMBUSTIBLES-FLUE PIPES

Flue pipes must be fitted in line with the distances specified in the table and must be suitable for the individual application.

Any combustible materials within the specified distances from the appliances must be protected by a suitable heat shield.

Protection can be gained by the use of -:

- Sheet metal heat shields and spacers.
- Heat resistant boards such as TAC board.
Combustible materials can be-:
- Wooden furniture.
- Curtains.
- Wooden panels or frames adjacent to the flue pipe or where it passes through the deck of the boat.
- Carpet or flooring close to the stove.
- Items near to the stove, which could fall onto it and ignite, should the boat suffer a slight impact or collision.

VENTILATION.

Ventilation plays a vital role in the fitting and sighting of any stove.

The provision of ventilation for these appliances is adequately covered by the requirements of the boat safety scheme.

25cm sq. minimum permanent ventilation, directly to outside air, must be provided.

FLOODED VAPOURIZING BURNER POTS.

When attempting to light any of the appliances, make sure that the pot is not flooded with oil by looking into the base of the burner.

If it is flooded remove the excess oil.

Never try to relight a hot stove; wait until it has cooled down.

Hot oil vapour is explosive.

Never try to light a flooded pot.

SECURELY FIX THE APPLIANCE

The stove must be securely fastened down so that it can resist impact or collision and it must be level in both directions.

Level the stove in both directions when the vessel is midway between its maximum and minimum trim conditions.

Bubble appliances must not be fitted if the maximum angle of trim exceeds 0.75 deg forward to aft or port to starboard.

Only suitably qualified persons can install unvented plumbing systems.

A suitable and serviceable fire extinguisher should always be readily accessible.

3. CHIMNEY

This is the one of the most interesting problems the installer has to deal with and as the chimney affects most aspects of running the stove, we take time here to list the following information for your consideration.

The power, (*suck or vacuum the chimney can develop*) depends upon the following-:

THE HEIGHT.

THE DIAMETER.

THE TEMPERATURE OF THE GASSES IN IT.

THE RESISTANCE OF THE INNER SURFACE OF THE FLUE PIPE OR PIPES.

THE TYPE OF TERMINAL.

THE PREVAILING ATMOSPHERIC CONDITIONS.

It is obvious that on a boat all the above elements are in short supply.

Normally, we have low flues which are small in diameter and generally not very well insulated, coupled with all these problems we have another one, which is that the boat moves across constantly changing surroundings, through locks, into headwinds and crosswinds, all creating major opportunity for down draughting to occur.

Any bend in any part of the chimney or roughness on the internal chimney wall will slow down the velocity of rising gases and reduce the effectiveness of the chimney.

Any slight reduction in the flue gas temperature will reduce the chimney vacuum or pull, hence when the stove is slowed down for all night burning, as the flue gas cools down the chimney vacuum reduces and as the chimney vacuum drops, the stove may well start to burn sooty. This problem is highlighted even more during very cold weather when the chimney can cool down even faster. In these situations careful attention to servicing and low fire setting is essential.

THE CHIMNEY RULES.

1. Always use a top outlet for flue pipe take off.
2. Always try to get the stove as low as possible in the boat, this will allow installation of maximum length flue pipe.
3. Clean or have the chimney cleaned regularly. (Frequency depends upon type of fuel and length of time used).

4. FUEL SUPPLY.

There are several problems relating to diesel fuel supply, which need be adequately addressed.

WAXING

Cold weather waxing or thickening alters the flow characteristics of diesel.

An adequate fuel feed supply can turn into an inadequate one when the temperature starts to fall.

The worst scenario is fuel feed pipe 50-60 feet long in 8mm dia pipe.

The best-case scenario is a fuel pipe 4 feet long in 10mm dia with insulated lagging.

AIR LOCKS

Air lock in oil feed pipe work must be avoided.

The pipe work must slope down to the appliance and be clipped level at 500mm intervals to prevent sagging.

Any rises in the pipe work will cause air locks on commissioning and after future oil run out situations, if it is not possible to run the pipe work in a steady slope then where changes occur a vertical venting leg should be fitted.

TRIM

Bubble appliances must not be fitted if the maximum angle of trim exceeds 0.75 deg forward to aft or port to starboard.

Level the stove in both directions when the vessel is midway between its maximum and minimum trim conditions.

A minimum pressure head of 254mm (10") is required.

This head is measured from the base of the oil tank to the top of the oil control valve. In some cases this head can be affected by the ballast or trim of the boat.

Take great care to try out all the different ballast and trim possibilities to make sure that adequate oil feed is always available at the outlet end of the fuel pipe before it enters the oil control valve at the stove.

TANK

If the stove is fitted at the bow of the boat, a bow tank is recommended.

The tank should comply with the requirements of the boat safety scheme and have:-

- A conveniently sized filler
- A means of venting.
- A conveniently located, easily visible, contents gauge.
- An isolation valve
- An easily replaceable cartridge filter.
- A suitable and substantial water trap

Do not use glass filter bowls, they are not acceptable under the boat safety scheme.

Make sure that your fuel supplier supplies you with appropriate fuel for wintertime running.

OIL LINE

The oil feed line starts after the fuel filter and proceeds to the point of entry, which is where the oil line goes into the cab or saloon of the boat.

The diameter of the oil line is dependent upon the length of run. See 3-2 on waxing and make sure that you have suitably sized compression fittings available.

At this point it is necessary to fit a 60 DEG C, remote sensing fire valve, designed to shut off the oil supply, should a fire occur near to the stove.

If the bubble stove is fitted up to the first bulkhead it will be necessary to fit the isolation valve outside the cabin or saloon of the boat. 5. Make sure that you have purged the oil feed line of all air and there is a steady and constant flow of oil available at the inlet to the oil valve. Make sure that all or any oil isolation devices are turned to the on position. Remember that the oil valve needs a min head of 300mm for gravity feed. When feeding from rear tanks with appliances fitted forward always be aware of the forward - aft trim of the vessel.

Do not use syphonic oil feeds to Bubble Appliances, oil should be fed by gravity or pumped via an appropriate pressure pump = head pressure less than 99mbar.

WATER CONTAMINATION

Because of the high risk of fuel contamination with water, we strongly recommend the fitting of a **high volume water trap**, in the oil supply line.

REMOTE SENSING FIREVALVES

There are two situations where a remote sensing firevalve should be fitted.

1. For fire protection fit a 60 deg C valve.
2. For over boil protection fit an additional 90 deg C valve.

For fire protection a remote sensing fire valve should be fitted as detailed in fig 3.

Run the capillary tube with the oil line up to the stove and carefully fit the sensing phial as follows

B1 Half Pod, B1 Oven and B2 at a low level fitted on two 15mm pipe clips.

Corner Stove and Corner Oven Stove on 15mm pipe clips in front of the drip tray on the fireplace hearth, directly in front of the combustion air restrictor.

Before it is fitted try the fender on the stove to make sure that the fender does not foul the sensing phial.

The sensing phial may be visible through the bottom of the fender, to mask it, paint it with matt black paint available from our sales desk.

When fitting the fire valve make sure that where the capillary and oil line go through the bulkhead in separate sleeved tubes, so that the capillary can be withdrawn separately should it ever need replacing.

For fitting of long oil feed lines which pass through bulkheads and various other parts of the boat it may well be necessary to fit more than one fire valve, especially where the oil line passes through an area where a fire could occur i.e. kitchen area etc.

ISOLATION VALVES.

Two isolation valves are required, one fitted directly into or close to the oil control valve to allow you or the service man to turn the oil off should the need arise, and one fitted directly into the oil tank before the fuel filter.

Always turn off the oil isolation valve serving the appliance before leaving the vessel unattended.

SLEEVING.

Where the oil line goes through the boat superstructure a suitable bulkhead fitting must be used.

OVERBOIL OR OVERHEAT PROTECTION OF THE APPLIANCE.

Where appliances are not fitted with an automatic thermostat an additional 90 DEG C, remote sensing

fire valve must be fitted directly in front of the oil control valve and the sensor from this valve has to be attached to the water jacket or the hot outlet pipe from the boiler.

The valve is calibrated to shut the oil supply down should the water temperature exceed 90 Deg C.

There is a re set button on the remote sensing fire valve which needs to be pressed in to re set the valve after it has tripped off.

4A LIGHTING & COMMISSIONING

A relevant oil control valve catalogue is supplied with each appliance and details of high and low fire adjusting screws are illustrated.

On the Toby valve the low fire screw is clearly visible as per TOBY MANUAL FIG 2

Before trying to light the burner in cold weather it is advisable to pre heat the flue pipe before lighting.

There are two different types of burner fitted to Bubble appliances.

The FB style burner fitted to the **B1 Half Pod, B1 Pie Pod and B2.**

The Socomef burner fitted to the **Corner Stove, Corner Oven Stove** and the **Back Cabin Cooker see sec 4B for lighting Socomef burners.**

1. LIGHTING B1 HALF POD, B1 PIE POD AND B2

When attempting to light the stove these are the rules, which must be followed.

1. Always make sure that the pot is **not** flooded with oil by looking down into the base of the pot.
2. Never try to light the stove if it is flooded with oil.
3. Always check that oil has not leaked from the appliance.
4. Do not light the stove and leave it unattended until it is settled down and stabilized into constant blue flame combustion on low fire. (This could take 10 to 20 minutes.)

On first light up it is advisable to warm the flue pipe up to try and create chimney draft.

Two Ways to Light the Stove

1. Through the lighting port B1 and B2 appliances only,
or
2. Directly into the base of the pot by removing the catalyser.

Lighting into the base of the Pot

On the first light up you may find this option better, as it is possible to see the oil trickle in to the pot more easily.

Use a heatproof glove when putting the catalysers back into the pot and it is important to replace them quickly whilst the flame is small.

Make sure that the oil is turned off.

Open the front door.

Remove the optional coal kit if fitted.

Remove the catalyser.

Turn the oil on and allow a small pool of oil to flow into the pot about the size of a small biscuit, **then turn the oil off.**

Note that on first light up it may take a few minutes for the oil to reach the pot as it has to fill the pipework before reaching the pot, take care not to allow excess oil to flow into the pot.

Light a small piece of firelighter and drop it into the oil, allow a few seconds for it to get going and then replace the catalyser and coal kit if fitted, and close the door.

Wait for approx. 1 minute until the pool of oil is alight and then **turn the oil on** to minimum setting no 1.

Watch the appliance for a few minutes and you will see the flame establish and settle down into blue flame combustion.

Allow the burner to run for a further 10 minutes before turning the appliance up to the higher settings.

If at any time during the ignition process large amounts of flame can be seen, turn the oil off immediately and wait until the flames die down before putting the oil on again at minimum setting.

Manual Lighting through the Lighting Port B1 and B2 appliances.

Check that the isolation valve is turned on.

Open the front door.

Remove the front apron on B1 Half Pod and B1 pie Pod.

Remove the lighting port plug by pulling it out of its tubular socket.

Turn the oil on to the first position via the flow control knob and allow a small pool of oil to flow into the pot about the size of a small biscuit.

Turn the oil off.

Cut a small piece of firelighter and stab it onto the spike.

Light it and push it into the lighting port tube, let the firelighter drop off the spike into the bottom of the pot.

Replace the lighting port plug back into the tube.

Close the front door.

Turn the fuel flow on again at the lowest setting

Watch the appliance for a few minutes until it settles down into blue flame combustion.

Allow the burner to run for a further 10 minutes before turning the appliance up to the higher settings.

If at any time during the ignition process large amounts of flame can be seen, turn the oil off immediately and wait until they die down before putting the oil on again.

Note there may be the occasional growl or audible vibration whilst the burner settles down into blue flame combustion.

COMMISSIONING THE HIGH & LOW FIRE, CHRYSTAL SERIES

Used in B1 Half Pod, B1 Pie Pod and B2

When the burner has established good blue flame combustion turn it up to half output. (Setting 3 on the fuel flow control knob) and let it stabilize.

Allow at least half an hour for the chimney to warm up thoroughly before making any adjustments to the high or low fire screws.

Turn the stove down onto minimum firing rate and let it stabilize.

After stabilization there should be a dull red glow in the lower catalyser with wispy blue flames flicking into and just over it.

If the flame falls into a dirty rolling yellow flame and the catalyser is not dull red then the low fire will need to be increased until it can support the required blue flame combustion.

To increase the low fire oil flow, screw the adjusting screw out by quarter turn increments.

When you are happy with the low fire, set the high fire.

Turn the oil flow knob up to setting 4, let the flame stabilize, and look at it, if it is stable and blue, turn it up slowly using the control knob, letting it stabilize after each movement, if the flame starts to go yellow with long flame combustion, it is running fuel rich and

the high fire screw needs adjusting to reduce the flow of oil. (Screw the adjuster screw in to reduce the high fire oil flow.)

Before adjusting the high fire screw, turn the flame down and let it stabilize in blue flame combustion, adjust the high fire screw by half a turn in and try turning the fuel flow up, if it is still fuel rich repeat the process until the high fire flame is running blue with just flicks of yellow in the tips.

To see a bubble stove running correctly see the following link

<https://www.youtube.com/watch?v=UqdQLFp3HkQ>

4B LIGHTING & COMMISSIONING THE BURNER SOCOMEF SERIES

1. LIGHTING CORNER STOVE, CORNER POD AND BACK CABIN COOKER.

When attempting to light the stove these are the rules, which must be followed.

1. Always make sure that the pot is not flooded with oil by looking down into the base of the pot.
2. Never try to light the stove if it is flooded with oil.
3. Always check that oil has not leaked from the appliance.
4. Do not light the stove and leave it unattended until it is settled down and stabilized into constant blue flame combustion on low fire. (This could take 10 to 20 minutes.)
5. Make sure that you have purged the oil feed line of all air and there is a steady and constant flow of oil available at the inlet to the oil valve. Make sure that all or any oil isolation devices are turned to the on position. Remember that the oil valve needs a min head of 300mm for gravity feed. When feeding from rear tanks with appliances fitted forward always be aware of the forward - aft trim of the vessel.
6. Do not use syphonic oil feeds to Bubble Appliances, oil should be fed by gravity or pumped via an appropriate pressure pump = head pressure less than 99mbar.

On first light up it is advisable to warm the flue pipe up to try and create chimney draft.

Lighting the Stove

Lighting the stove takes a little time and patience; the following procedure should be adopted.

In the case of the Corner appliances, open the front door and in the case of the Back Cabin Cooker remove the hot plate and top baffle to gain access to the

burner, note that the back cabin cooker has a lighting port fitted behind the lower ash pit door.

Remove the coal kit if it has been supplied with the stove.

Lift the inner mesh catalyser from the burner.



Look into the bottom of the pot and turn the oil on at full rate, allow oil to flow into the bottom of the pot to form a pool about the size of a small digestive biscuit and then turn the oil off.

Note that on first light up it may take a few minutes for the oil to reach the pot as it has to fill the pipework before reaching the pot.

Do not allow any depth of oil to build up.

Light a small piece of firelighter (about the size of a pineapple chunk) and place it into the centre of the oil pool.

Replace the mesh catalyser and the coal kit, if fitted and then leave the door slightly open whilst the firelighter gets the oil going.

After 30 to 40 seconds, you will notice the flame start to establish itself and spread around the bottom of the pot.

When this occurs, close the door or replace the baffle and top plate and then turn the oil on to its minimum setting.

After two or three minutes the flame should slowly change from yellow into blue flame combustion and settle down to a steady burn.

Note there may be the occasional growl or audible vibration whilst the burner settles down into blue flame combustion.

Allow the burner 10 - 15 minutes to stabilise and the increase the flow of oil as required, moving by one increment of the dial only.

Do not leave the appliance unattended during the lighting and stabilising procedure.

COMMISSIONING THE HIGH AND LOW FIRE SOCOMEF BURNERS.

Corner Stove, Corner Pod and Back Cabin Cooker.

Note that Back cabin Cookers are pre commissioned at the factory and do not need adjusting.

A relevant oil control valve catalogue is supplied with each appliance and details of high and low fire adjusting screws are illustrated.

On the Toby valve the low fire screw is clearly visible as per TOBY MANUAL FIG 2

When the burner has established good blue flame combustion turn it up to half output. (Setting 3 on the fuel flow control knob) and let it stabilize for a minute. Allow at least half an hour for the chimney to warm up thoroughly before making any adjustments to the high or low fire screws.

Turn the stove down onto minimum firing rate and again let it stabilize.

After stabilization there should be a dull red glow in the catalyser with wispy blue flames flickering just over the top of it, approximately level with the top of the pot.

If the flame falls into a dirty rolling yellow flame and the catalyser is not dull red then the low fire will need to be increased until the burner can support the required blue flame combustion.

When you are happy with the low fire, set the high fire.

Turn the oil flow knob up to setting 4, let the flame stabilize, and look at it, if it is stable and blue, turn it up slowly using the control knob, letting it stabilize after each movement, if the flame starts to go yellow with long flame combustion, it is running fuel rich and the high fire screw needs adjusting to reduce the flow of oil. (Screw the adjuster screw in to reduce the high fire oil flow.)

Before adjusting the high fire screw, turn the flame down and let it stabilize in blue flame combustion, adjust the high fire screw by half a turn in and try turning the fuel flow up, if it is still fuel rich repeat the process until the high fire flame is running blue with flicks of yellow in the tips.

On the Socomef pot, the high fire flame will be set approx. 40mm above the top of the pot.

NOTE THAT THIS PROCEDURE WILL NOT BE POSSIBLE IF THE CHIMNEY RULES HAVE NOT BEEN ADHERED TO.

THE HIGH FIRE SETTING WILL HAVE TO BE ADJUSTED IN LINE WITH THE AVAILABLE GENERATED CHIMNEY VACUUM IE

THE FLUE PIPE MUST BE A MINIMUM OF 1.8 METERS HIGH FOR LOW FIRE AND 2.1 METERS FOR HIGH FIRE.

INSTALLING ENGINEERS SHOULD NOT LEAVE THE APPLIANCE UNDER THE CONTROL OF THE CUSTOMER UNLESS THE APPLIANCE HAS BEEN CORRECTLY COMMISSIONED.

TO SEE HOW THE BURNER SHOULD OPERATE COMMISSIONING AND INSTALLING ENGINEERS SHOULD VISIT

<https://www.youtube.com/watch?v=UqdQLFp3HkQ>

This video shows a stove running from low to high fire and back to low fire. Note that this video is filmed on a normal house chimney and so it may not be possible to get exactly the same conditions on a typical boat flue as the fuel air ratio will not be exactly the same, hence the need for fine tuning the oil flow to the chimney air flow capability.

5. FIREPLACE.

Unless one is built into the appliance, always fit appliances on a suitable drip tray.

The possibility of oil drops leaking from the stove must be considered; a suitable oil drip tray must be fitted and designed in such a way, as it will contain any oil leaks or drips.

Normally the tray will cover the footprint of the stove, the oil valve and isolation device.

It will be oil tight and have a vertical up stand of at least 30mm. This should give a minimum containment volume of 2 litres.

It will be securely fastened down to the vessel and the appliance must be securely fastened down to the oil drip tray.

Make sure that drip trays are tested to ensure that they do not leak when filled with oil.

The hearth must be:-

FLAT - SECURE - FIREPROOF AND LEVEL IN BOTH DIRECTIONS.

Use materials, which are easy to keep clean and fireproof such as tiles, asbestolux or vermiculite boarding with a suitable weight resistant liner.

The vertical walls of the fireplace must also be made from fireproof materials.

Use fireproof, rockwool infill behind the fireplace panels to protect any combustible insulation materials

such as spray foam.

6. DISTANCES FROM COMBUSTIBLES (APPLIANCES)

Stove Type	ABOVE	SIDES.	BACK	FRONT	HEARTH Non Combustible Material
B1 HALF POD and OVEN VERSION	500	300	150 FROM HEAT SHIELD	300 to allow door opening.	30MM THICK x 100 projection at the front and sides
BOAT B2	600	300	150 FROM HEAT SHIELD	300 to allow door opening.	30MM THICK x 100 projection at the front and sides
CORNER and OVEN VERSION	500	75	100 FROM HEAT SHIELD	300 to allow door opening.	30MM THICK x 100 projection at the front.
BACK CABIN COOKER	500	150	100 FROM HEAT SHIELD	300 to allow door opening.	25MM THICK x 150 projection at sides

7. DISTANCES FROM NON COMBUSTIBLES (APPLIANCES)

Stove Type	ABOVE	SIDES.	BACK	FRONT	HEARTH Non Combustible Material
B1 HALF POD and OVEN VERSION	300	150	150 FROM HEAT SHIELD	300 to allow door opening.	30MM THICK x 100 projection at the front and sides.
BOAT B2	300	150	150 FROM HEAT SHIELD	300 to allow door opening.	30MM THICK x 100 projection at the front and sides.
CORNER and OVEN VERSION	200	150	25 FROM HEAT SHIELD	300 to allow door opening.	30MM THICK x 100 projection at the front and sides.
BACK CABIN COOKER	500	75	50 FROM HEAT SHIELD	300 to allow door opening.	25MM THICK x 75 projection at sides

Note that the back cabin cooker can have the oil control valve fitted to the rear or the left hand side in each case the positioning of the valve will affect the fireplace and spacing considerations, see sizes of cooker to establish requirements.

8. DISTANCES FROM COMBUSTIBLES (FLUE PIPES)

For all appliances-:

1. Single skin flue pipes. Horizontal Distance = 50mm **when fitted within the deck flange** at the top of the chimney system, protected by the fire stop spacer.
2. Single skin flue pipes. Horizontal Distance = 150mm **when exposed in the saloon or living space.**
3. Twin Wall Insulated flue pipes. Horizontal Distance = 30 mm for insulated flue pipe systems.

9. ILLUSTRATIONS

FIG 1. STOVE DISTANCE FROM COMBUSTIBLES

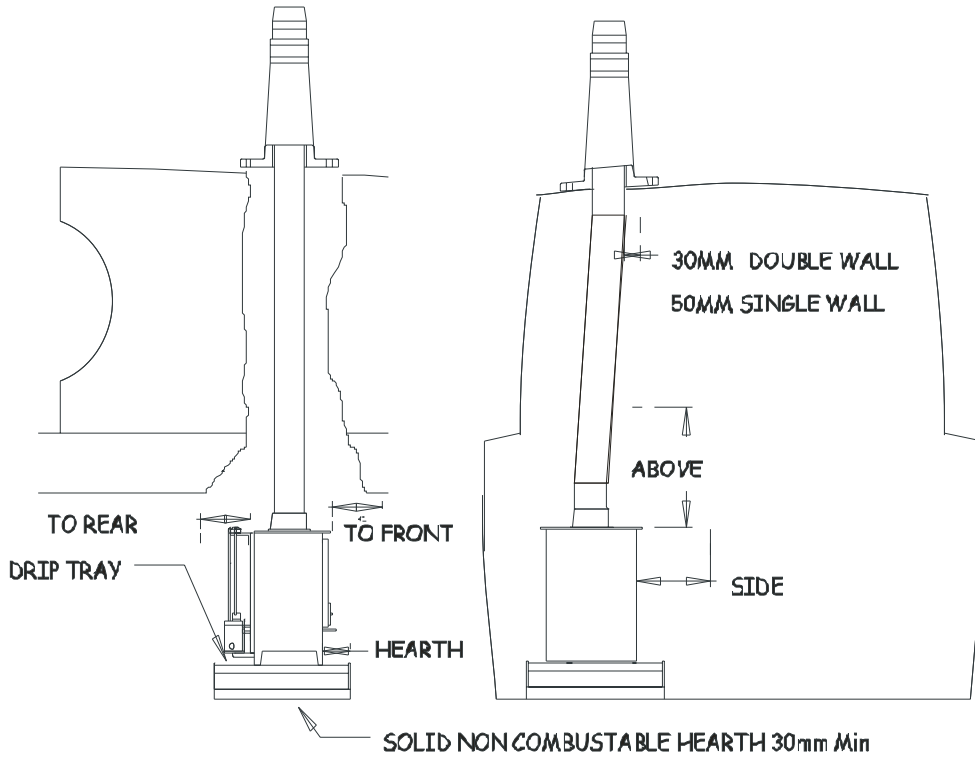

FIG 2 BUBBLE MK1 FABRICATED DECK FLANGE LAYOUT

Note that there is mk3 system which is now available and detailed on our web site.

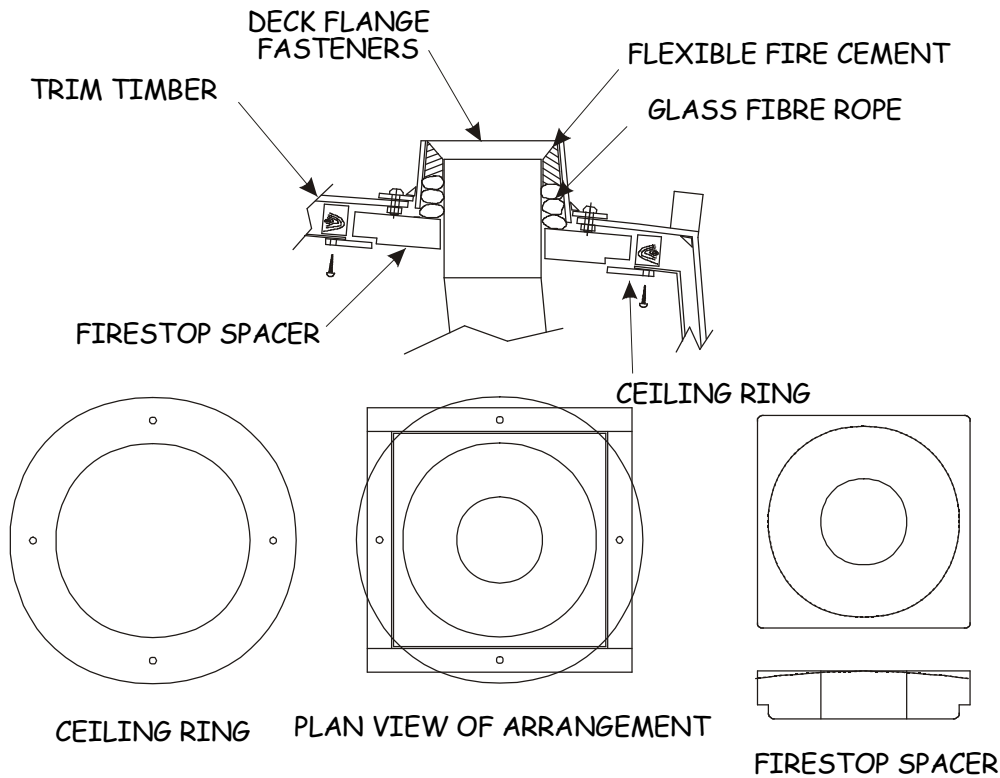
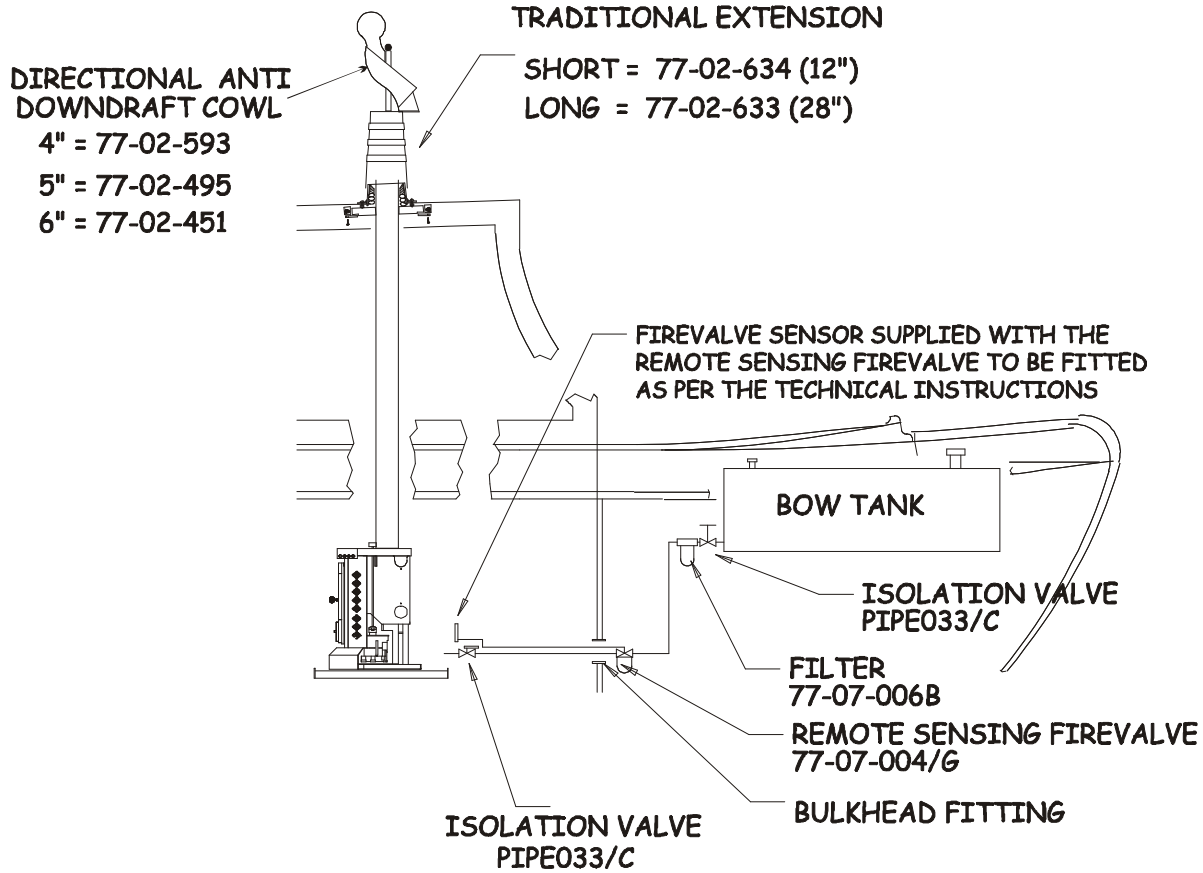

FIG 3 TYPICAL OIL FEED LAYOUT



COPYRIGHT HARWORTH HEATING LTD 080800

FIG 4 TYPICAL PUMING LAYOUTS

Drq 1

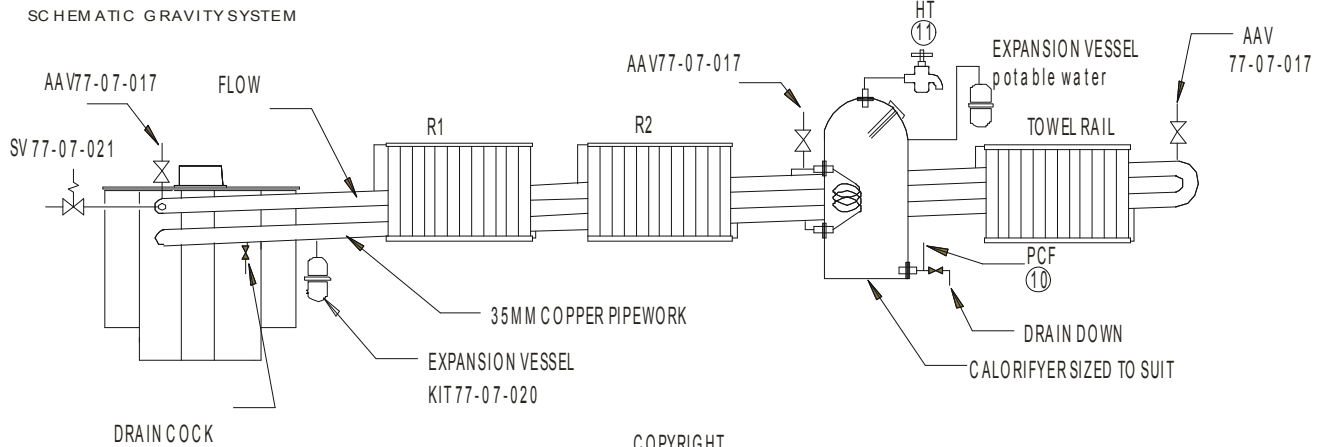

COPYRIGHT BUBBLE PRODUCTS 2013

Drg 2

SCHEMATIC PUMPED SYSTEM ISS 2 OF 28-10-17

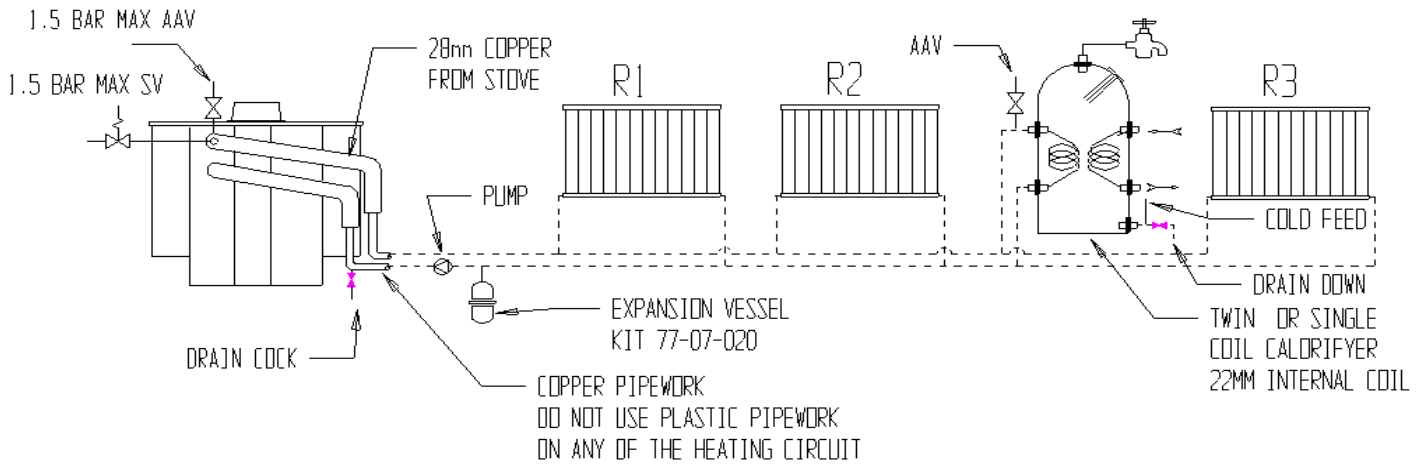

Drg 3

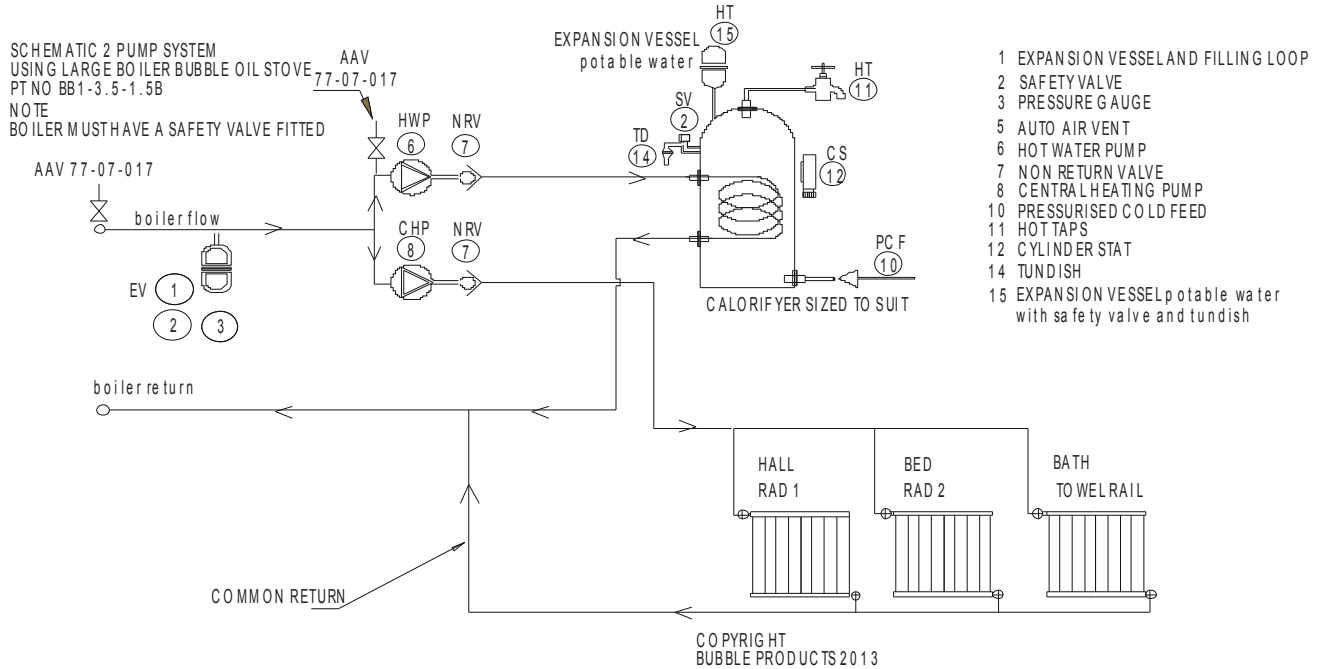

10. STOVE DIMENSIONS

10-1 BB1 HALF POD AND PIE POD DIMENSIONS

Note that the B1 Pie Pod has the same footprint dimensions but the vertical height is 830mm.

**B1 HALF OIL POD OF 12-02-15
OVERALL DIMENSIONS
BOILER AND NON BOILER VERSIONS**

**.WEIGHT 35 KG NON BOILER
.WEIGHT 45 KG SMALL BOILER
.WEIGHT 50 KG LARGE BOILER**

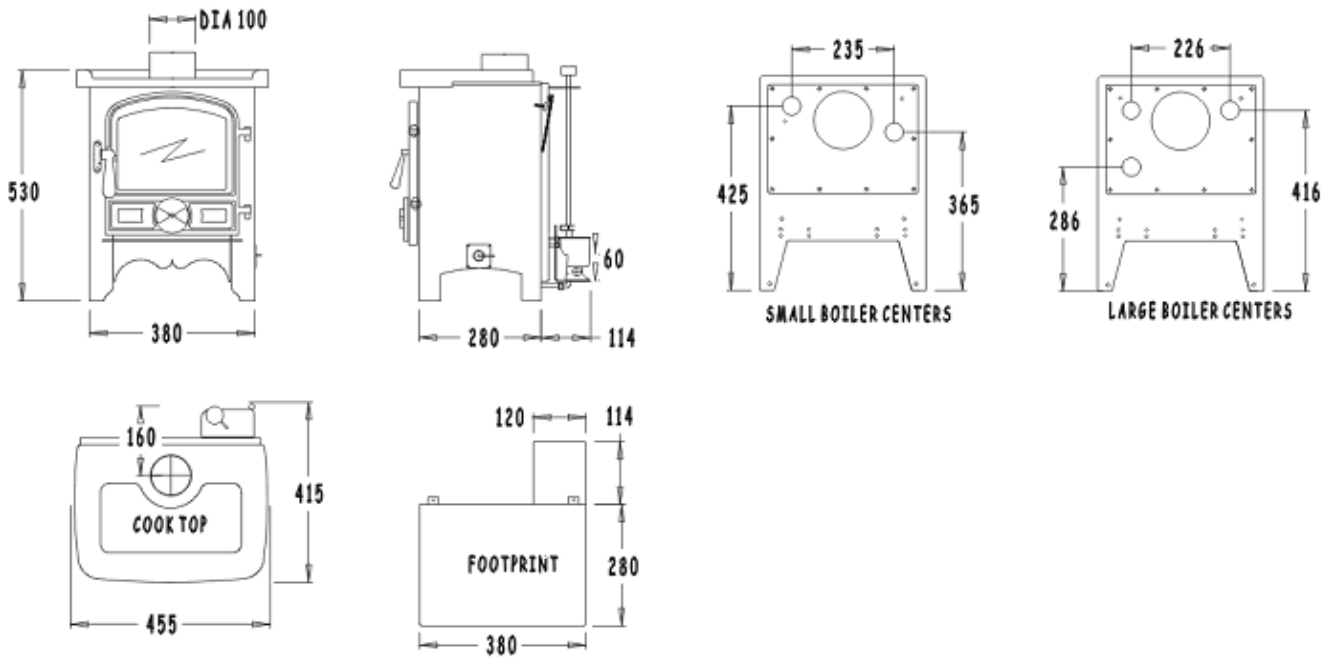

10-2 CORNER STOVE AND CORNER PIE POD DIMENSIONS

Note that the Corner Pie Pod has the same footprint dimensions but the vertical height is 840mm.

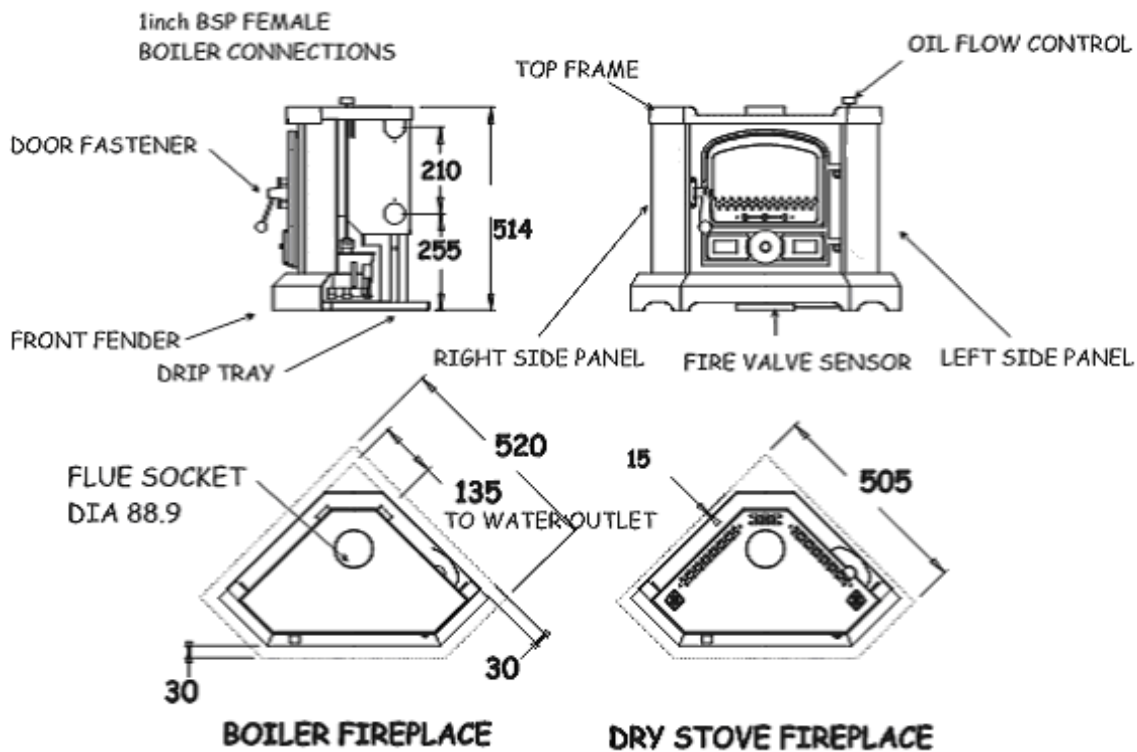

10-3 B2 STOVE DIMENSIONS

Note that the B2 Pie Pod has the same footprint dimensions but the vertical height is 830mm.

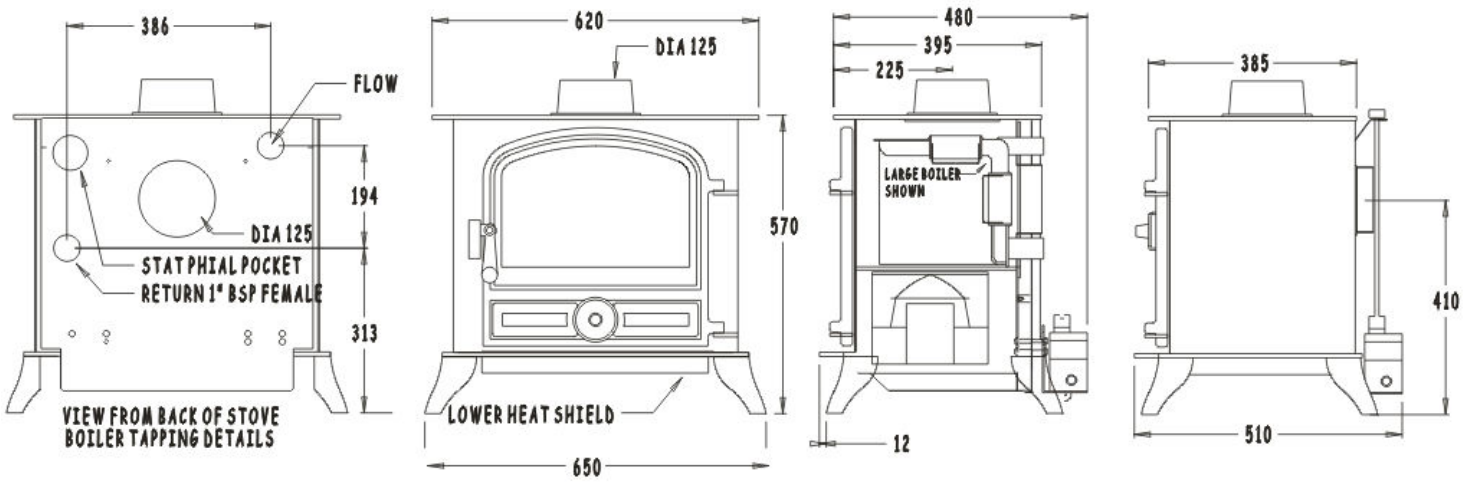

10-4 BACK CABIN COOKER DIMENSIONS

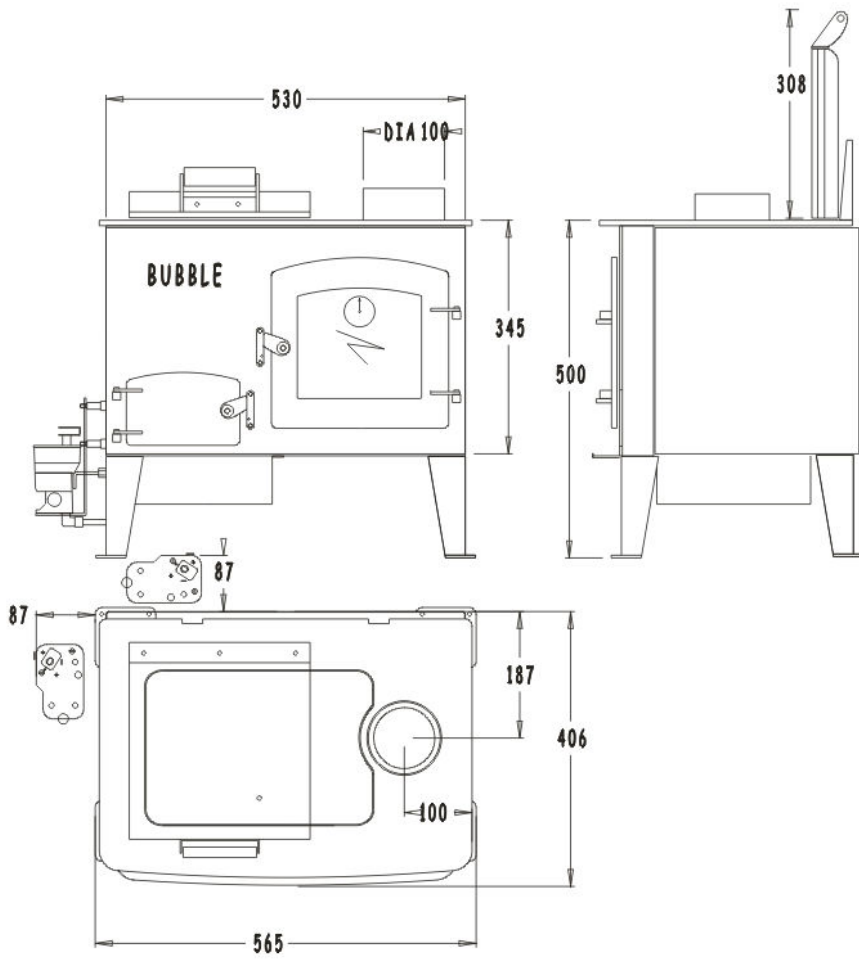

11. OIL CONSUMPTION RATES

		MAX HEAT OUTPUT TO WATER	MAX HEAT OUTPUT TO SPACE	MINIMUM OIL FLOW CC'S PER MIN	MAXIMUM OIL FLOW CC'S PER MINUTE
--	--	--------------------------	--------------------------	-------------------------------	----------------------------------

B1 HALF POD & OVEN DERIVATIVE					
Free Standing	From 1.6kW to 5kW		5kW	4 = (1.6kW)	12 = (5kW)
Free Standing	From 1.6kW to 5kW	2kW	3kW	4 = (1.6kW)	12 = (5kW)
Free Standing	From 1.6kW to 6kW	5kW	2kW	4 = (1.6kW)	13 = (6kW)

CORNER STOVE & OVEN DERIVATIVE					
Free Standing	From 1kW to 4kW		4kW	3 = (1kW)	10 = (4kW)
Free Standing	From 1kW to 4kW	3kW	1kW	3 = (1kW)	10 = (4kW)

BUBBLE 2					
Free Standing	From 1.6kW to 5kW		5kW	4 = (1.6kW)	13 = (5kW)
Free Standing	From 1.6kW to 8kW		8kW	4 = (1.6kW)	16 = (8kW)
Free Standing	From 1.6kW to 8kW	3kW	5kW	4 = (1.6kW)	16 = (8kW)
Free Standing	From 1.6kW to 8kW	9kW	2kW	4 = (1.6kW)	22 = (11kW)

BACK CABIN COOKER					
Free Standing	From 1.6kW to 5kW		3kW	4 = (1.6kW)	7 = (3kW)
Free Standing	From 1.6kW to 5kW	1kW	2kW	4 = (1.6kW)	7 = (3kW)

© HARWORTH HEATING LTD 30.6.98

This publication may not be copied by any means, without written permission from the authors.

These products are subject to continuous development and improvement and it is consequently acknowledged that due to this process there may be some omissions and errors.

This publication is intended only to assist the reader in the use of this product and therefore Harworth Heating Ltd shall not be liable for any loss or damage whatsoever arising from the use of any information, error or omission found in this publication.

The appliances mentioned in this publication can only be installed and serviced by approved personnel.

Approved personnel means that they must HAVE BEEN SUITABLY TRAINED, if there are any

reliability issues reported back to **Harworth Heating** or **Bubble Products**, the installing engineer will be responsible for carrying out any rectification work.

For details of suitable training courses contact: - www.oftec.org

12. NORMATIVE REFERENCES

Boat installation work comes under the control of: -
The Boat Safety Scheme.

This scheme provides statutory requirements and associated EN / BS Standards for most aspects of installation work on boats.

Further information and a copy of the requirements can be obtained from:-

www.boatsafetyscheme.com

Where guidance for oil fired appliances is not readily available from the Boat safety Scheme publication, we then point out a list of standards which pertain to domestic installations and which are generally covered by the latest version of the English Building Regulations Doc J.

When read in conjunction with:-

1. Our installation instructions.
2. The Boat Safety Scheme rules.
3. The other standards detailed, enough information should be provided to allow for a safe installation.

BS 5440	Flues.
BS 6999	Flues
BS 7840	Fuel Hoses.
BS EN1057	Copper Tubes.
BS1344 Part 3 1988 ISO8290 1987	Flues.
BS EN 1443:2003	Chimneys - General requirements.
BS EN1856 part 1 replacing BS 4543	Flues.
BS EN1856 part 2 & BS 715 1993	Flues.
BS 1945: 1971	Stove door
BS EN 10296-1	Steel tubes
BS ISO 10088:2001	
BS EN ISO 9094-2003	
BS EN 10297-1	Steel tubes
BS EN 13384-1	Chimneys
BS EN 10088-1:2005	Stainless steels - Part 1: List of stainless steels

INSTALLATION & GENERAL INSTRUCTIONS



Silent Simplicity just for you!

MARINE OIL STOVES ©

ISSUE 15 @ 22-06-18

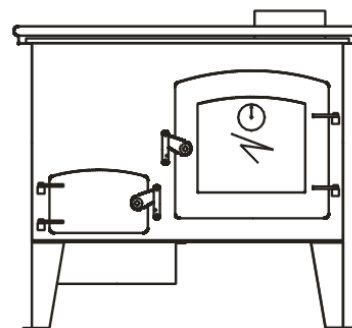
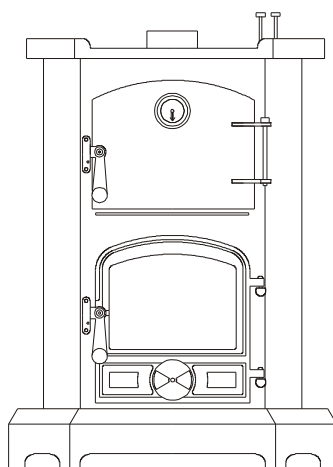
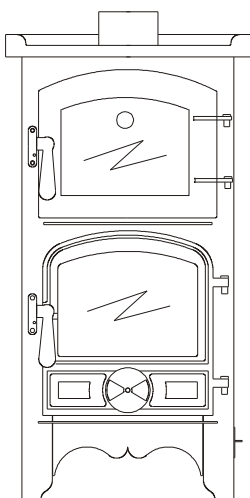
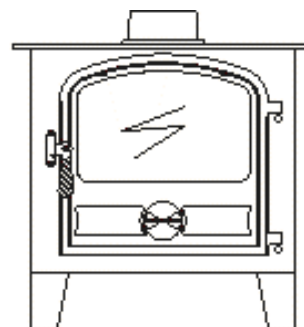
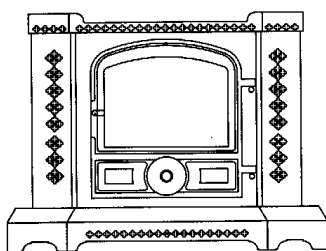
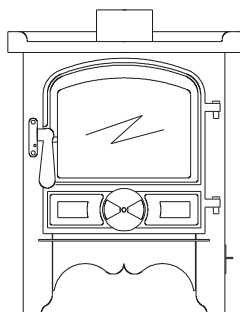

www.harworthheating.co.uk

INDEX

1. BEFORE STARTING THE JOB.	3
FITTING OPTIONS.	3
ABOUT THE APPLIANCES	3
2. SAFETY.	4
FUMES	4
FIRE	4
BURNS	4
CLEARANCES FROM COMBUSTIBLES	4
CLEARANCES FROM COMBUSTIBLES-FLUE PIPES	5
VENTILATION.	5
FLOODED VAPOURIZING BURNER POTS.	5
SECURELY FIX THE APPLIANCE	5
3. CHIMNEY	5
THE HEIGHT.	5
THE DIAMETER.	5
THE TEMPERATURE OF THE GASSES IN IT.	5
THE RESISTANCE OF THE INNER SURFACE OF THE FLUE PIPE OR PIPES.	5
THE TYPE OF TERMINAL.	5
THE PREVAILING ATMOSPHERIC CONDITIONS.	5
THE CHIMNEY RULES.	6
4. FUEL SUPPLY.	6
WAXING	6
AIR LOCKS	6
TRIM	6
TANK	6
OIL LINE	6
WATER CONTAMINATION	6
REMOTE SENSING FIREVALVES	7
ISOLATION VALVES.	7
SLEEVING.	7
OVERBOIL OR OVERHEAT PROTECTION OF THE APPLIANCE.	7
4A LIGHTING & COMMISSIONING	7
1. LIGHTING B1 HALF POD, B1 PIE POD AND B2	7
COMMISSIONING THE HIGH & LOW FIRE, CHRYSTAL SERIES	8
4B LIGHTING & COMMISSIONING THE BURNER SOCOMEF SERIES	9
1. LIGHTING CORNER STOVE, CORNER POD AND BACK CABIN COOKER.	9
COMMISSIONING THE HIGH AND LOW FIRE SOCOMEF BURNERS.	10
5. FIREPLACE.	10
6. DISTANCES FROM COMBUSTIBLES (APPLIANCES)	11
7. DISTANCES FROM NON COMBUSTIBLES (APPLIANCES)	11
8. DISTANCES FROM COMBUSTIBLES (FLUE PIPES)	11
9. ILLUSTRATIONS	12
FIG 1. STOVE DISTANCE FROM COMBUSTIBLES	12
FIG 2 BUBBLE MK1 FABRICATED DECK FLANGE LAYOUT	12
FIG 3 TYPICAL OIL FEED LAYOUT	13
FIG 4 TYPICAL PUMBING LAYOUTS	13
10. STOVE DIMENSIONS	14
10-1 BB1 HALF POD AND PIE POD DIMENSIONS	14
10-2 CORNER STOVE AND CORNER PIE POD DIMENSIONS	15
10-3 B2 STOVE DIMENSIONS	15
10-4 BACK CABIN COOKER DIMENSIONS	16
12. NORMATIVE REFERENCES	18

If you have any difficulties please phone our technical help line on-:

01302 742520 fax 01302 750573

e-mail contact@bubbleproducts.co.uk

<http://www.bubbleproducts.co.uk>

1. BEFORE STARTING THE JOB.

THE FOLLOWING NOTES PROVIDE INFORMATION FOR INSTALLATION OF THE FOLLOWING APPLIANCES.

Boat Bubble No 1 AND HALF POD, Dry Small and Large Boiler Appliances

Boat Bubble No 2 Dry Small and Large Boiler Appliances

Marine Corner Bubble Wet and Dry appliances

Bubble No 1 Cooking Stove plus boiler options.

Corner Cooking Stove plus boiler options.

Back Cabin Oil Fired Cooker.

FITTING OPTIONS.

There are normally two different situations that the installer may be faced with:-

1. A new build installation.

An established boat installation, (which has not had oil stove fitted).

2. A replacement installation, where there has been a solid fuel stove fitted previously.

Each of the situations will present differing problems which will be:-

- Where to locate the stove.
- How to deal with fireplace design.
- Where to locate the oil tank.
- How to get an oil supply to the stove.
- How to fit the chimney.
- How to connect water to the stove.
- How to disconnect and remove the stove, easily.

The new build situation should be the easiest.

The established boat situation will require careful attention to the sighting of the stove in relation to flue positions and existing fittings positions.

In replacement situations it may well be necessary to blank off the existing through roof flue position and cut a fresh one to suit the new location and comply with our instructions on flue design.

ABOUT THE APPLIANCES

Generally described as a space heater or space heater and cooker, which burns diesel oil in a controlled

manner utilizing a chimney to discharge the products of combustion.

The appliance generates heat from burning oil mixed with air in a vaporizing pot located in the bottom of the stove.

Once the appliance has been ignited, oil goes into the pot at a steady and controlled rate via a gravity feed which is metered by the OIL CONTROL VALVE; the oil flow can be controlled from minimum to maximum or any setting in between determined by the set position of the oil flow control knob.

Air is sucked into the pot by the natural action of the negative pressure in the chimney.

To allow the chimney to work correctly it is essential that you have adequate, unrestricted ventilation into the area where the stove is situated.

The amount of oil that can be successfully burned is directly proportional to the amount of air that the chimney can draw into the pot and so to achieve adequate combustion a balanced and appropriate flow of both oil and air is required.

The stove will provide space or combined space and water heating and in some cases cooking as well.

Where cooking and water heating are combined one feature will inevitably effect the other.

There are different versions of each appliance within the total range.

Some of the appliances are supplied as Dry, Small Boiler and Large Boiler versions namely B1 Half Pod, B1 Oven and B2.

Some of the appliances are supplied just as Dry and Large Boiler versions namely Corner Stove and Corner Oven Stove.

The Back Cabin Cooker can be supplied with or without a small boiler for domestic hot water heating only.(1kw)

All of the boilers are high water content and suitable for pumped or gravity systems and pressurised or open vented systems ASSUMING THAT THEY ARE INSTALLED BY SUITABLY QUALIFIED PERSONS.

All the appliances are fitted with a descaling device which should be rotated on a two weekly cycle to descale the oil inlet pipe.

Where applicable, appliances must not be operated with the glass front door opened or cracked, or without the lighting port plug fitted.

Where applicable, the door glass may require light cleaning occasionally depending upon the continuous running time of the stove.

Appliances must be securely bolted down to resist impact or collision and must be level in both directions.

All the appliances are supplied with clamp down brackets except the Back Cabin Cooker which must be fastened down through the foot plates.

The top of the appliances can be used for warming and cooking.

The oven appliances have a comprehensive range of cooking facilities with both oven and hot plate cooking available.

Some appliances can also be supplied with a coal kit, which just like a solid fuel stove, coal effect will only be available when the stove is running at maximum or near maximum performance.

Suitable deck flanges, flue systems and anti-downdraft cowls must be used.

CONTROLS

The output of the stove is regulated by the amount of oil allowed to go into it and this function is controlled by the -:

OIL CONTROL VALVE (O.C.V.), Turning the knob anti clockwise controls the oil flow.

2. SAFETY.

Take care to make sure that all safety and ventilation issues are adequately addressed.

FUMES

Always fit a suitable Smoke and Carbon Monoxide alarm within 1.5meters of the appliance.

Make sure that the function is checked on regular basis. (weekly)

Make sure that the alarm can be heard in the sleeping quarters.

Here are the main causes of fume or smoke to leak from the stove.

- The chimney is blocked.
- There are too many bends in the chimney.
- The above deck chimney extension is not high enough.
- The boat is moored in a position near to high buildings or trees and downdraughting is occurring.
- The chimney or parts of it are not airtight.

- There are unusually strong cross winds.

If down draughting occurs turn the appliance off until the winds subside and do not attempt to re-ignite the appliance until it has completely cooled down.

When it has cooled down, before attempting to ignite the appliance remove the catalyser and examine the base of the pot to make sure that there is no oil left in the pot, if there are signs of oil in the pot do not attempt to ignite the appliance until it has been completely dried out.

FIRE

Fire can be caused by a variety of potential danger points and because of the space limitation on boats; this risk is ever present and must be adequately assessed.

The main danger is the effects of heat from the stove on combustible materials and boat occupants.

Make sure that all combustibles are adequately protected from the effects of heat radiation.

Appliances must stand on a fireproof base of minimum thickness 30mm or a purpose made stand.

Floors in front of the stove must have suitable fire protection.

Built in stove heat shields should not be removed under any circumstances.

BURNS

During normal, day-to-day use, many parts of the stove, pipe work, and chimney will become too hot to touch.

Hot surfaces must be adequately protected to prevent anyone falling on to, or touching them.

Suitable fireguards for the appliance and chimney must be fitted.

Fireguards must comply with BS6539.

Always use heatproof gloves when working on or near to a hot stove.

CLEARANCES FROM COMBUSTIBLES

The appliances must be fitted in line with the distances specified in the tables.

All hearths and fireplaces must be made from non-combustible materials and adequately designed for the job.

CLEARANCES FROM COMBUSTIBLES-FLUE PIPES

Flue pipes must be fitted in line with the distances specified in the table and must be suitable for the individual application.

Any combustible materials within the specified distances from the appliances must be protected by a suitable heat shield.

Protection can be gained by the use of -:

- Sheet metal heat shields and spacers.
- Heat resistant boards such as TAC board.
Combustible materials can be-:
- Wooden furniture.
- Curtains.
- Wooden panels or frames adjacent to the flue pipe or where it passes through the deck of the boat.
- Carpet or flooring close to the stove.
- Items near to the stove, which could fall onto it and ignite, should the boat suffer a slight impact or collision.

VENTILATION.

Ventilation plays a vital role in the fitting and sighting of any stove.

The provision of ventilation for these appliances is adequately covered by the requirements of the boat safety scheme.

25cm sq. minimum permanent ventilation, directly to outside air, must be provided.

FLOODED VAPOURIZING BURNER POTS.

When attempting to light any of the appliances, make sure that the pot is not flooded with oil by looking into the base of the burner.

If it is flooded remove the excess oil.

Never try to relight a hot stove; wait until it has cooled down.

Hot oil vapour is explosive.

Never try to light a flooded pot.

SECURELY FIX THE APPLIANCE

The stove must be securely fastened down so that it can resist impact or collision and it must be level in both directions.

Level the stove in both directions when the vessel is midway between its maximum and minimum trim conditions.

Bubble appliances must not be fitted if the maximum angle of trim exceeds 0.75 deg forward to aft or port to starboard.

Only suitably qualified persons can install unvented plumbing systems.

A suitable and serviceable fire extinguisher should always be readily accessible.

3. CHIMNEY

This is the one of the most interesting problems the installer has to deal with and as the chimney affects most aspects of running the stove, we take time here to list the following information for your consideration.

The power, (*suck or vacuum the chimney can develop*) depends upon the following-:

THE HEIGHT.

THE DIAMETER.

THE TEMPERATURE OF THE GASSES IN IT.

THE RESISTANCE OF THE INNER SURFACE OF THE FLUE PIPE OR PIPES.

THE TYPE OF TERMINAL.

THE PREVAILING ATMOSPHERIC CONDITIONS.

It is obvious that on a boat all the above elements are in short supply.

Normally, we have low flues which are small in diameter and generally not very well insulated, coupled with all these problems we have another one, which is that the boat moves across constantly changing surroundings, through locks, into headwinds and crosswinds, all creating major opportunity for down draughting to occur.

Any bend in any part of the chimney or roughness on the internal chimney wall will slow down the velocity of rising gases and reduce the effectiveness of the chimney.

Any slight reduction in the flue gas temperature will reduce the chimney vacuum or pull, hence when the stove is slowed down for all night burning, as the flue gas cools down the chimney vacuum reduces and as the chimney vacuum drops, the stove may well start to burn sooty. This problem is highlighted even more during very cold weather when the chimney can cool down even faster. In these situations careful attention to servicing and low fire setting is essential.

THE CHIMNEY RULES.

1. Always use a top outlet for flue pipe take off.
2. Always try to get the stove as low as possible in the boat, this will allow installation of maximum length flue pipe.
3. Clean or have the chimney cleaned regularly. (Frequency depends upon type of fuel and length of time used).

4. FUEL SUPPLY.

There are several problems relating to diesel fuel supply, which need be adequately addressed.

WAXING

Cold weather waxing or thickening alters the flow characteristics of diesel.

An adequate fuel feed supply can turn into an inadequate one when the temperature starts to fall.

The worst scenario is fuel feed pipe 50-60 feet long in 8mm dia pipe.

The best-case scenario is a fuel pipe 4 feet long in 10mm dia with insulated lagging.

AIR LOCKS

Air lock in oil feed pipe work must be avoided.

The pipe work must slope down to the appliance and be clipped level at 500mm intervals to prevent sagging.

Any rises in the pipe work will cause air locks on commissioning and after future oil run out situations, if it is not possible to run the pipe work in a steady slope then where changes occur a vertical venting leg should be fitted.

TRIM

Bubble appliances must not be fitted if the maximum angle of trim exceeds 0.75 deg forward to aft or port to starboard.

Level the stove in both directions when the vessel is midway between its maximum and minimum trim conditions.

A minimum pressure head of 254mm (10") is required.

This head is measured from the base of the oil tank to the top of the oil control valve. In some cases this head can be affected by the ballast or trim of the boat.

Take great care to try out all the different ballast and trim possibilities to make sure that adequate oil feed is always available at the outlet end of the fuel pipe before it enters the oil control valve at the stove.

TANK

If the stove is fitted at the bow of the boat, a bow tank is recommended.

The tank should comply with the requirements of the boat safety scheme and have:-

- A conveniently sized filler
- A means of venting.
- A conveniently located, easily visible, contents gauge.
- An isolation valve
- An easily replaceable cartridge filter.
- A suitable and substantial water trap

Do not use glass filter bowls, they are not acceptable under the boat safety scheme.

Make sure that your fuel supplier supplies you with appropriate fuel for wintertime running.

OIL LINE

The oil feed line starts after the fuel filter and proceeds to the point of entry, which is where the oil line goes into the cab or saloon of the boat.

The diameter of the oil line is dependent upon the length of run. See 3-2 on waxing and make sure that you have suitably sized compression fittings available.

At this point it is necessary to fit a 60 DEG C, remote sensing fire valve, designed to shut off the oil supply, should a fire occur near to the stove.

If the bubble stove is fitted up to the first bulkhead it will be necessary to fit the isolation valve outside the cabin or saloon of the boat. 5. Make sure that you have purged the oil feed line of all air and there is a steady and constant flow of oil available at the inlet to the oil valve. Make sure that all or any oil isolation devices are turned to the on position. Remember that the oil valve needs a min head of 300mm for gravity feed. When feeding from rear tanks with appliances fitted forward always be aware of the forward - aft trim of the vessel.

Do not use syphonic oil feeds to Bubble Appliances, oil should be fed by gravity or pumped via an appropriate pressure pump = head pressure less than 99mbar.

WATER CONTAMINATION

Because of the high risk of fuel contamination with water, we strongly recommend the fitting of a **high volume water trap**, in the oil supply line.

REMOTE SENSING FIREVALVES

There are two situations where a remote sensing firevalve should be fitted.

1. For fire protection fit a 60 deg C valve.
2. For over boil protection fit an additional 90 deg C valve.

For fire protection a remote sensing fire valve should be fitted as detailed in fig 3.

Run the capillary tube with the oil line up to the stove and carefully fit the sensing phial as follows

B1 Half Pod, B1 Oven and B2 at a low level fitted on two 15mm pipe clips.

Corner Stove and Corner Oven Stove on 15mm pipe clips in front of the drip tray on the fireplace hearth, directly in front of the combustion air restrictor.

Before it is fitted try the fender on the stove to make sure that the fender does not foul the sensing phial.

The sensing phial may be visible through the bottom of the fender, to mask it, paint it with matt black paint available from our sales desk.

When fitting the fire valve make sure that where the capillary and oil line go through the bulkhead in separate sleeved tubes, so that the capillary can be withdrawn separately should it ever need replacing.

For fitting of long oil feed lines which pass through bulkheads and various other parts of the boat it may well be necessary to fit more than one fire valve, especially where the oil line passes through an area where a fire could occur i.e. kitchen area etc.

ISOLATION VALVES.

Two isolation valves are required, one fitted directly into or close to the oil control valve to allow you or the service man to turn the oil off should the need arise, and one fitted directly into the oil tank before the fuel filter.

Always turn off the oil isolation valve serving the appliance before leaving the vessel unattended.

SLEEVING.

Where the oil line goes through the boat superstructure a suitable bulkhead fitting must be used.

OVERBOIL OR OVERHEAT PROTECTION OF THE APPLIANCE.

Where appliances are not fitted with an automatic thermostat an additional 90 DEG C, remote sensing

fire valve must be fitted directly in front of the oil control valve and the sensor from this valve has to be attached to the water jacket or the hot outlet pipe from the boiler.

The valve is calibrated to shut the oil supply down should the water temperature exceed 90 Deg C.

There is a re set button on the remote sensing fire valve which needs to be pressed in to re set the valve after it has tripped off.

4A LIGHTING & COMMISSIONING

A relevant oil control valve catalogue is supplied with each appliance and details of high and low fire adjusting screws are illustrated.

On the Toby valve the low fire screw is clearly visible as per TOBY MANUAL FIG 2

Before trying to light the burner in cold weather it is advisable to pre heat the flue pipe before lighting.

There are two different types of burner fitted to Bubble appliances.

The FB style burner fitted to the **B1 Half Pod, B1 Pie Pod and B2.**

The Socomef burner fitted to the **Corner Stove, Corner Oven Stove** and the **Back Cabin Cooker see sec 4B for lighting Socomef burners.**

1. LIGHTING B1 HALF POD, B1 PIE POD AND B2

When attempting to light the stove these are the rules, which must be followed.

1. Always make sure that the pot is **not** flooded with oil by looking down into the base of the pot.
2. Never try to light the stove if it is flooded with oil.
3. Always check that oil has not leaked from the appliance.
4. Do not light the stove and leave it unattended until it is settled down and stabilized into constant blue flame combustion on low fire. (This could take 10 to 20 minutes.)

On first light up it is advisable to warm the flue pipe up to try and create chimney draft.

Two Ways to Light the Stove

1. Through the lighting port B1 and B2 appliances only,
or
2. Directly into the base of the pot by removing the catalyser.

Lighting into the base of the Pot

On the first light up you may find this option better, as it is possible to see the oil trickle in to the pot more easily.

Use a heatproof glove when putting the catalysers back into the pot and it is important to replace them quickly whilst the flame is small.

Make sure that the oil is turned off.

Open the front door.

Remove the optional coal kit if fitted.

Remove the catalyser.

Turn the oil on and allow a small pool of oil to flow into the pot about the size of a small biscuit, **then turn the oil off.**

Note that on first light up it may take a few minutes for the oil to reach the pot as it has to fill the pipework before reaching the pot, take care not to allow excess oil to flow into the pot.

Light a small piece of firelighter and drop it into the oil, allow a few seconds for it to get going and then replace the catalyser and coal kit if fitted, and close the door.

Wait for approx. 1 minute until the pool of oil is alight and then **turn the oil on** to minimum setting no 1.

Watch the appliance for a few minutes and you will see the flame establish and settle down into blue flame combustion.

Allow the burner to run for a further 10 minutes before turning the appliance up to the higher settings.

If at any time during the ignition process large amounts of flame can be seen, turn the oil off immediately and wait until the flames die down before putting the oil on again at minimum setting.

Manual Lighting through the Lighting Port B1 and B2 appliances.

Check that the isolation valve is turned on.

Open the front door.

Remove the front apron on B1 Half Pod and B1 pie Pod.

Remove the lighting port plug by pulling it out of its tubular socket.

Turn the oil on to the first position via the flow control knob and allow a small pool of oil to flow into the pot about the size of a small biscuit.

Turn the oil off.

Cut a small piece of firelighter and stab it onto the spike.

Light it and push it into the lighting port tube, let the firelighter drop off the spike into the bottom of the pot.

Replace the lighting port plug back into the tube.

Close the front door.

Turn the fuel flow on again at the lowest setting

Watch the appliance for a few minutes until it settles down into blue flame combustion.

Allow the burner to run for a further 10 minutes before turning the appliance up to the higher settings.

If at any time during the ignition process large amounts of flame can be seen, turn the oil off immediately and wait until they die down before putting the oil on again.

Note there may be the occasional growl or audible vibration whilst the burner settles down into blue flame combustion.

COMMISSIONING THE HIGH & LOW FIRE, CHRYSTAL SERIES

Used in B1 Half Pod, B1 Pie Pod and B2

When the burner has established good blue flame combustion turn it up to half output. (Setting 3 on the fuel flow control knob) and let it stabilize.

Allow at least half an hour for the chimney to warm up thoroughly before making any adjustments to the high or low fire screws.

Turn the stove down onto minimum firing rate and let it stabilize.

After stabilization there should be a dull red glow in the lower catalyser with wispy blue flames flicking into and just over it.

If the flame falls into a dirty rolling yellow flame and the catalyser is not dull red then the low fire will need to be increased until it can support the required blue flame combustion.

To increase the low fire oil flow, screw the adjusting screw out by quarter turn increments.

When you are happy with the low fire, set the high fire.

Turn the oil flow knob up to setting 4, let the flame stabilize, and look at it, if it is stable and blue, turn it up slowly using the control knob, letting it stabilize after each movement, if the flame starts to go yellow with long flame combustion, it is running fuel rich and

the high fire screw needs adjusting to reduce the flow of oil. (Screw the adjuster screw in to reduce the high fire oil flow.)

Before adjusting the high fire screw, turn the flame down and let it stabilize in blue flame combustion, adjust the high fire screw by half a turn in and try turning the fuel flow up, if it is still fuel rich repeat the process until the high fire flame is running blue with just flicks of yellow in the tips.

To see a bubble stove running correctly see the following link

<https://www.youtube.com/watch?v=UqdQLFp3HkQ>

4B LIGHTING & COMMISSIONING THE BURNER SOCOMEF SERIES

1. LIGHTING CORNER STOVE, CORNER POD AND BACK CABIN COOKER.

When attempting to light the stove these are the rules, which must be followed.

1. Always make sure that the pot is not flooded with oil by looking down into the base of the pot.
2. Never try to light the stove if it is flooded with oil.
3. Always check that oil has not leaked from the appliance.
4. Do not light the stove and leave it unattended until it is settled down and stabilized into constant blue flame combustion on low fire. (This could take 10 to 20 minutes.)
5. Make sure that you have purged the oil feed line of all air and there is a steady and constant flow of oil available at the inlet to the oil valve. Make sure that all or any oil isolation devices are turned to the on position. Remember that the oil valve needs a min head of 300mm for gravity feed. When feeding from rear tanks with appliances fitted forward always be aware of the forward - aft trim of the vessel.
6. Do not use syphonic oil feeds to Bubble Appliances, oil should be fed by gravity or pumped via an appropriate pressure pump = head pressure less than 99mbar.

On first light up it is advisable to warm the flue pipe up to try and create chimney draft.

Lighting the Stove

Lighting the stove takes a little time and patience; the following procedure should be adopted.

In the case of the Corner appliances, open the front door and in the case of the Back Cabin Cooker remove the hot plate and top baffle to gain access to the

burner, note that the back cabin cooker has a lighting port fitted behind the lower ash pit door.

Remove the coal kit if it has been supplied with the stove.

Lift the inner mesh catalyser from the burner.



Look into the bottom of the pot and turn the oil on at full rate, allow oil to flow into the bottom of the pot to form a pool about the size of a small digestive biscuit and then turn the oil off.

Note that on first light up it may take a few minutes for the oil to reach the pot as it has to fill the pipework before reaching the pot.

Do not allow any depth of oil to build up.

Light a small piece of firelighter (about the size of a pineapple chunk) and place it into the centre of the oil pool.

Replace the mesh catalyser and the coal kit, if fitted and then leave the door slightly open whilst the firelighter gets the oil going.

After 30 to 40 seconds, you will notice the flame start to establish itself and spread around the bottom of the pot.

When this occurs, close the door or replace the baffle and top plate and then turn the oil on to its minimum setting.

After two or three minutes the flame should slowly change from yellow into blue flame combustion and settle down to a steady burn.

Note there may be the occasional growl or audible vibration whilst the burner settles down into blue flame combustion.

Allow the burner 10 - 15 minutes to stabilise and the increase the flow of oil as required, moving by one increment of the dial only.

Do not leave the appliance unattended during the lighting and stabilising procedure.

COMMISSIONING THE HIGH AND LOW FIRE SOCOMEF BURNERS.

Corner Stove, Corner Pod and Back Cabin Cooker.

Note that Back cabin Cookers are pre commissioned at the factory and do not need adjusting.

A relevant oil control valve catalogue is supplied with each appliance and details of high and low fire adjusting screws are illustrated.

On the Toby valve the low fire screw is clearly visible as per TOBY MANUAL FIG 2

When the burner has established good blue flame combustion turn it up to half output. (Setting 3 on the fuel flow control knob) and let it stabilize for a minute. Allow at least half an hour for the chimney to warm up thoroughly before making any adjustments to the high or low fire screws.

Turn the stove down onto minimum firing rate and again let it stabilize.

After stabilization there should be a dull red glow in the catalyser with wispy blue flames flickering just over the top of it, approximately level with the top of the pot.

If the flame falls into a dirty rolling yellow flame and the catalyser is not dull red then the low fire will need to be increased until the burner can support the required blue flame combustion.

When you are happy with the low fire, set the high fire.

Turn the oil flow knob up to setting 4, let the flame stabilize, and look at it, if it is stable and blue, turn it up slowly using the control knob, letting it stabilize after each movement, if the flame starts to go yellow with long flame combustion, it is running fuel rich and the high fire screw needs adjusting to reduce the flow of oil. (Screw the adjuster screw in to reduce the high fire oil flow.)

Before adjusting the high fire screw, turn the flame down and let it stabilize in blue flame combustion, adjust the high fire screw by half a turn in and try turning the fuel flow up, if it is still fuel rich repeat the process until the high fire flame is running blue with flicks of yellow in the tips.

On the Socomef pot, the high fire flame will be set approx. 40mm above the top of the pot.

NOTE THAT THIS PROCEDURE WILL NOT BE POSSIBLE IF THE CHIMNEY RULES HAVE NOT BEEN ADHERED TO.

THE HIGH FIRE SETTING WILL HAVE TO BE ADJUSTED IN LINE WITH THE AVAILABLE GENERATED CHIMNEY VACUUM IE

THE FLUE PIPE MUST BE A MINIMUM OF 1.8 METERS HIGH FOR LOW FIRE AND 2.1 METERS FOR HIGH FIRE.

INSTALLING ENGINEERS SHOULD NOT LEAVE THE APPLIANCE UNDER THE CONTROL OF THE CUSTOMER UNLESS THE APPLIANCE HAS BEEN CORRECTLY COMMISSIONED.

TO SEE HOW THE BURNER SHOULD OPERATE COMMISSIONING AND INSTALLING ENGINEERS SHOULD VISIT

<https://www.youtube.com/watch?v=UqdQLFp3HkQ>

This video shows a stove running from low to high fire and back to low fire. Note that this video is filmed on a normal house chimney and so it may not be possible to get exactly the same conditions on a typical boat flue as the fuel air ratio will not be exactly the same, hence the need for fine tuning the oil flow to the chimney air flow capability.

5. FIREPLACE.

Unless one is built into the appliance, always fit appliances on a suitable drip tray.

The possibility of oil drops leaking from the stove must be considered; a suitable oil drip tray must be fitted and designed in such a way, as it will contain any oil leaks or drips.

Normally the tray will cover the footprint of the stove, the oil valve and isolation device.

It will be oil tight and have a vertical up stand of at least 30mm. This should give a minimum containment volume of 2 litres.

It will be securely fastened down to the vessel and the appliance must be securely fastened down to the oil drip tray.

Make sure that drip trays are tested to ensure that they do not leak when filled with oil.

The hearth must be:-

FLAT - SECURE - FIREPROOF AND LEVEL IN BOTH DIRECTIONS.

Use materials, which are easy to keep clean and fireproof such as tiles, asbestolux or vermiculite boarding with a suitable weight resistant liner.

The vertical walls of the fireplace must also be made from fireproof materials.

Use fireproof, rockwool infill behind the fireplace panels to protect any combustible insulation materials

such as spray foam.

6. DISTANCES FROM COMBUSTIBLES (APPLIANCES)

Stove Type	ABOVE	SIDES.	BACK	FRONT	HEARTH Non Combustible Material
B1 HALF POD and OVEN VERSION	500	300	150 FROM HEAT SHIELD	300 to allow door opening.	30MM THICK x 100 projection at the front and sides
BOAT B2	600	300	150 FROM HEAT SHIELD	300 to allow door opening.	30MM THICK x 100 projection at the front and sides
CORNER and OVEN VERSION	500	75	100 FROM HEAT SHIELD	300 to allow door opening.	30MM THICK x 100 projection at the front.
BACK CABIN COOKER	500	150	100 FROM HEAT SHIELD	300 to allow door opening.	25MM THICK x 150 projection at sides

7. DISTANCES FROM NON COMBUSTIBLES (APPLIANCES)

Stove Type	ABOVE	SIDES.	BACK	FRONT	HEARTH Non Combustible Material
B1 HALF POD and OVEN VERSION	300	150	150 FROM HEAT SHIELD	300 to allow door opening.	30MM THICK x 100 projection at the front and sides.
BOAT B2	300	150	150 FROM HEAT SHIELD	300 to allow door opening.	30MM THICK x 100 projection at the front and sides.
CORNER and OVEN VERSION	200	150	25 FROM HEAT SHIELD	300 to allow door opening.	30MM THICK x 100 projection at the front and sides.
BACK CABIN COOKER	500	75	50 FROM HEAT SHIELD	300 to allow door opening.	25MM THICK x 75 projection at sides

Note that the back cabin cooker can have the oil control valve fitted to the rear or the left hand side in each case the positioning of the valve will affect the fireplace and spacing considerations, see sizes of cooker to establish requirements.

8. DISTANCES FROM COMBUSTIBLES (FLUE PIPES)

For all appliances-:

1. Single skin flue pipes. Horizontal Distance = 50mm **when fitted within the deck flange** at the top of the chimney system, protected by the fire stop spacer.
2. Single skin flue pipes. Horizontal Distance = 150mm **when exposed in the saloon or living space.**
3. Twin Wall Insulated flue pipes. Horizontal Distance = 30 mm for insulated flue pipe systems.

9. ILLUSTRATIONS

FIG 1. STOVE DISTANCE FROM COMBUSTIBLES

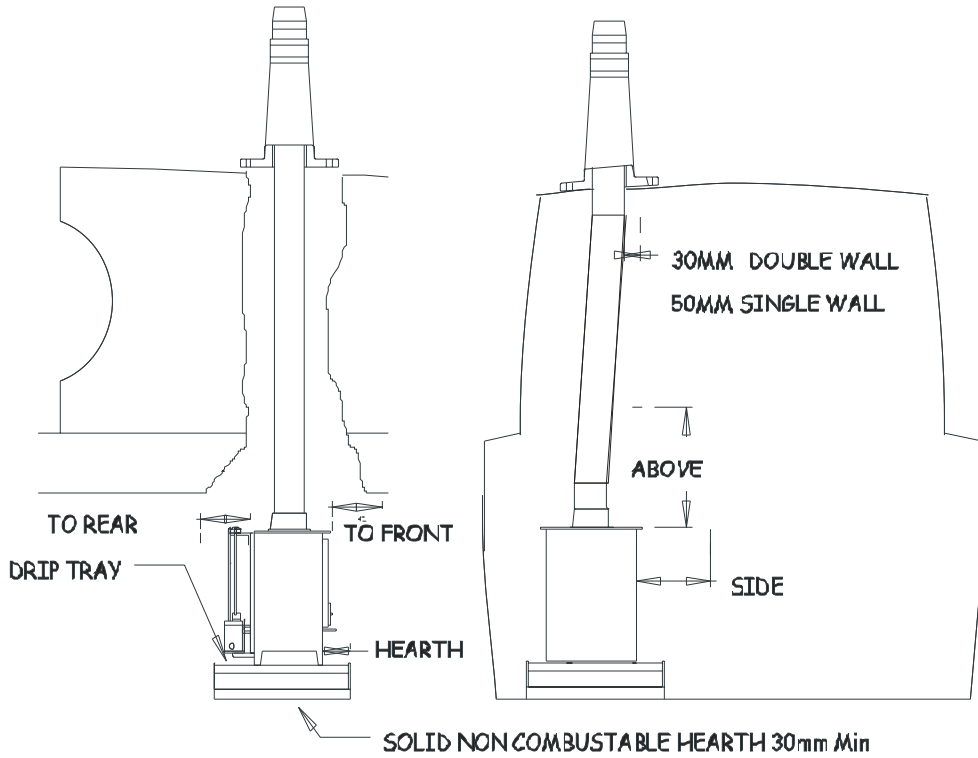

FIG 2 BUBBLE MK1 FABRICATED DECK FLANGE LAYOUT

Note that there is mk3 system which is now available and detailed on our web site.

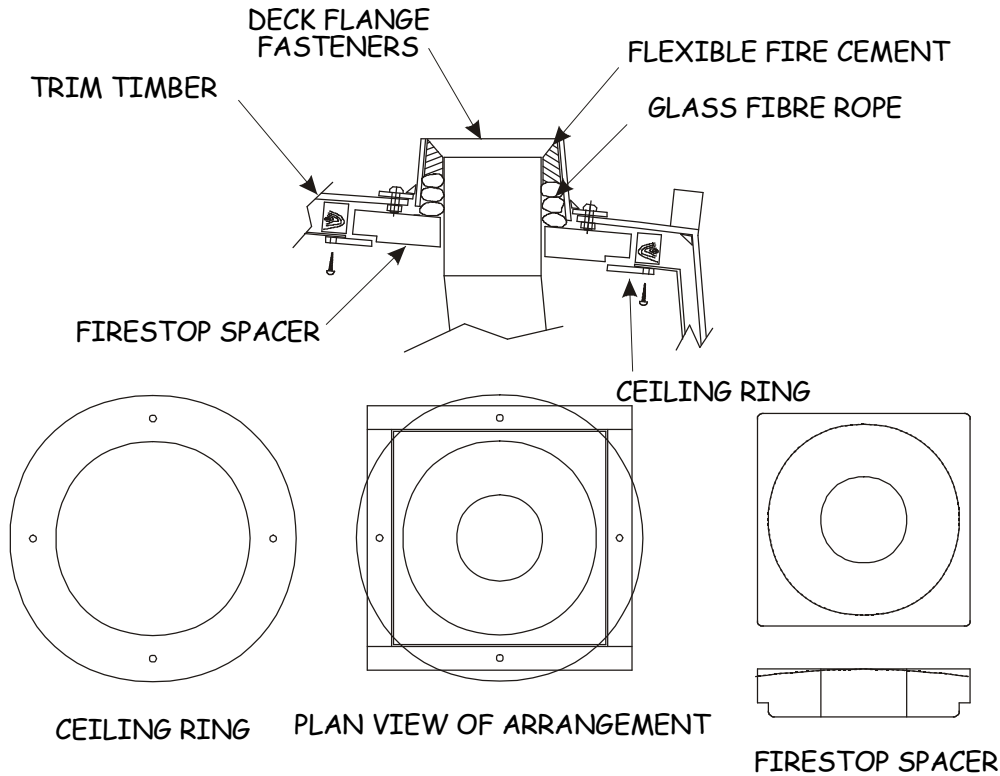
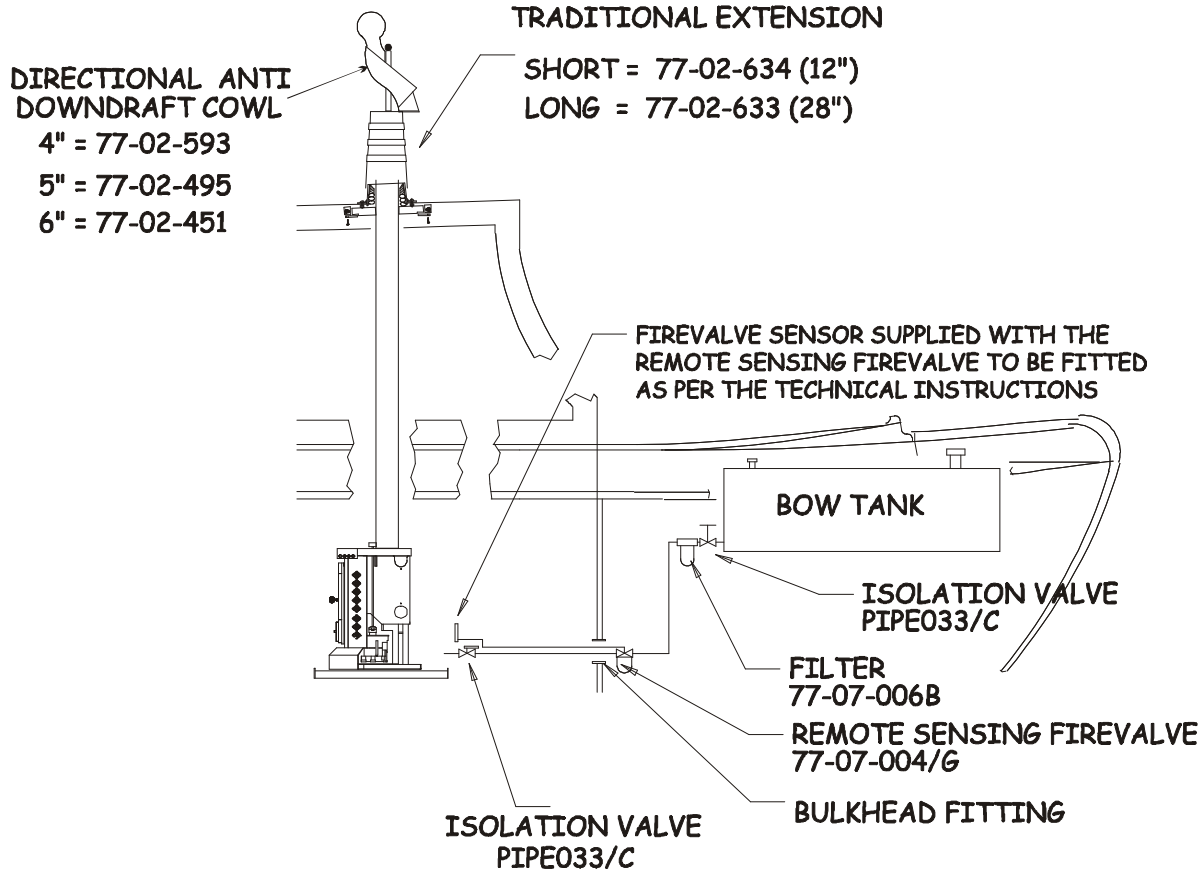

FIG 3 TYPICAL OIL FEED LAYOUT



COPYRIGHT HARWORTH HEATING LTD 080800

FIG 4 TYPICAL PUMING LAYOUTS

Drq 1

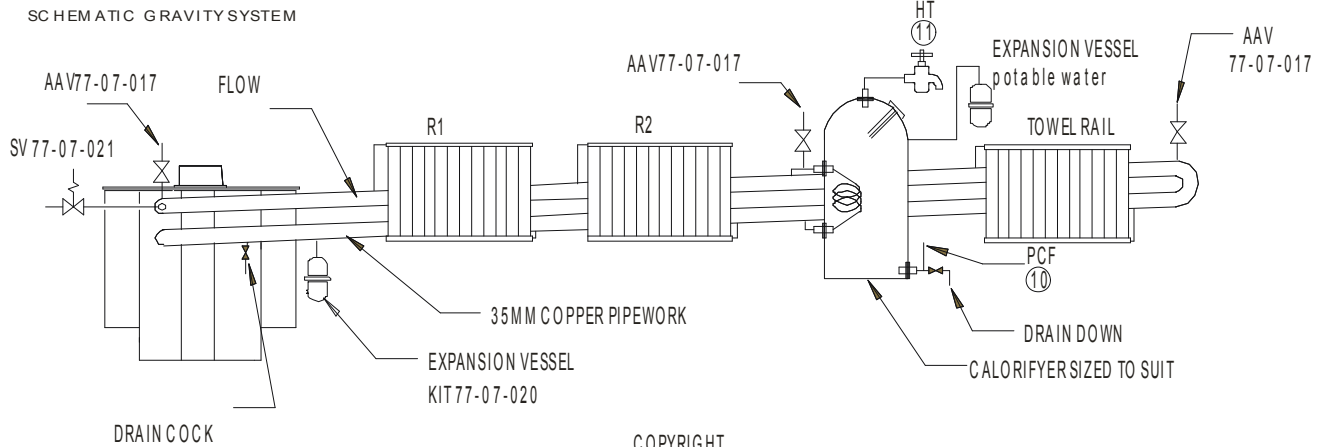

COPYRIGHT BUBBLE PRODUCTS 2013

Drg 2

SCHEMATIC PUMPED SYSTEM ISS 2 OF 28-10-17

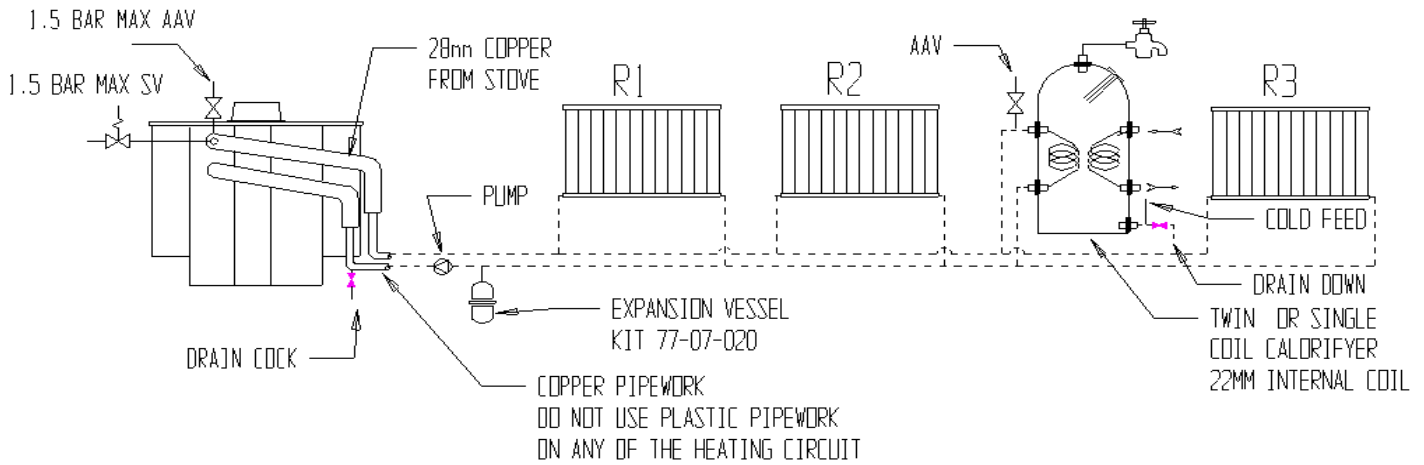

Drg 3

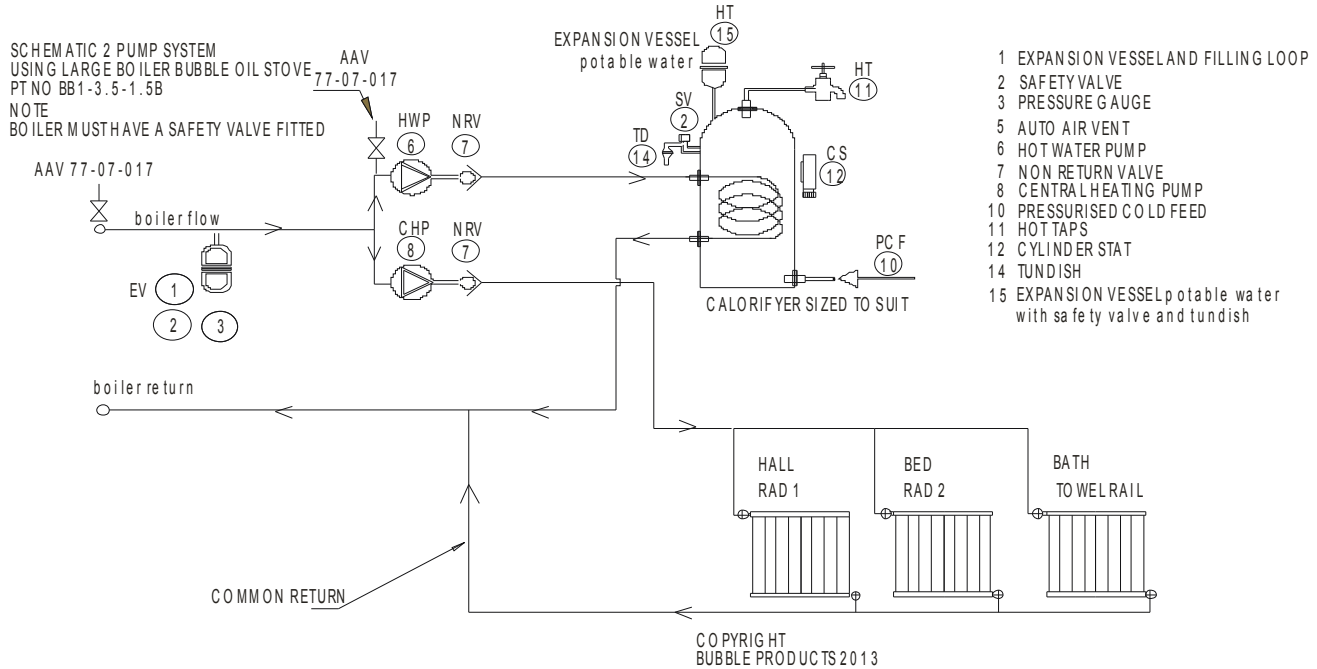

10. STOVE DIMENSIONS

10-1 BB1 HALF POD AND PIE POD DIMENSIONS

Note that the B1 Pie Pod has the same footprint dimensions but the vertical height is 830mm.

**B1 HALF OIL POD OF 12-02-15
OVERALL DIMENSIONS
BOILER AND NON BOILER VERSIONS**

**.WEIGHT 35.KG NON BOILER
.WEIGHT 45.KG SMALL BOILER
.WEIGHT 50.KG LARGE BOILER**

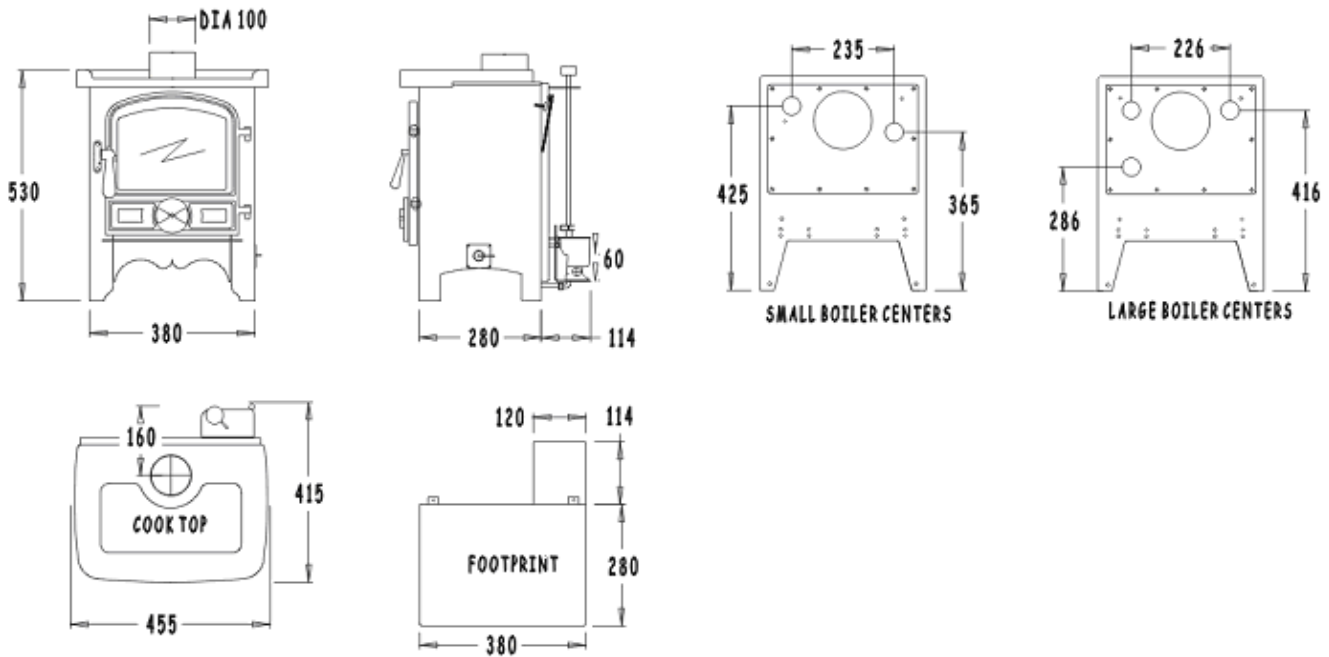

10-2 CORNER STOVE AND CORNER PIE POD DIMENSIONS

Note that the Corner Pie Pod has the same footprint dimensions but the vertical height is 840mm.

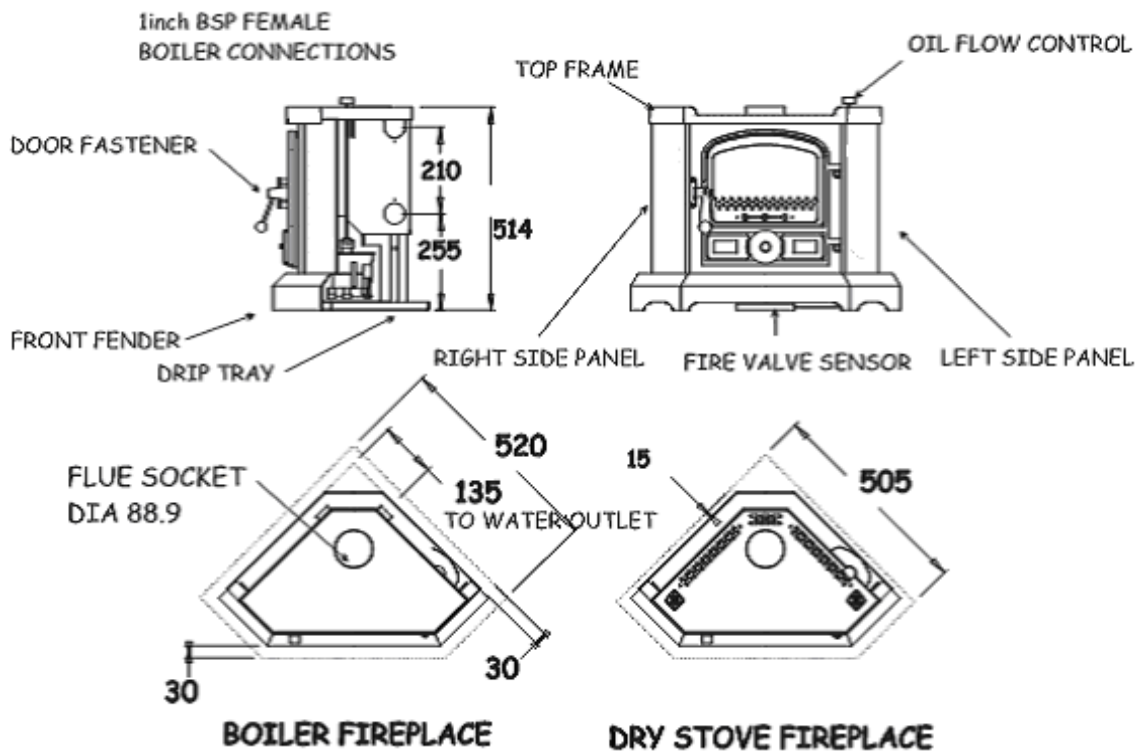

10-3 B2 STOVE DIMENSIONS

Note that the B2 Pie Pod has the same footprint dimensions but the vertical height is 830mm.

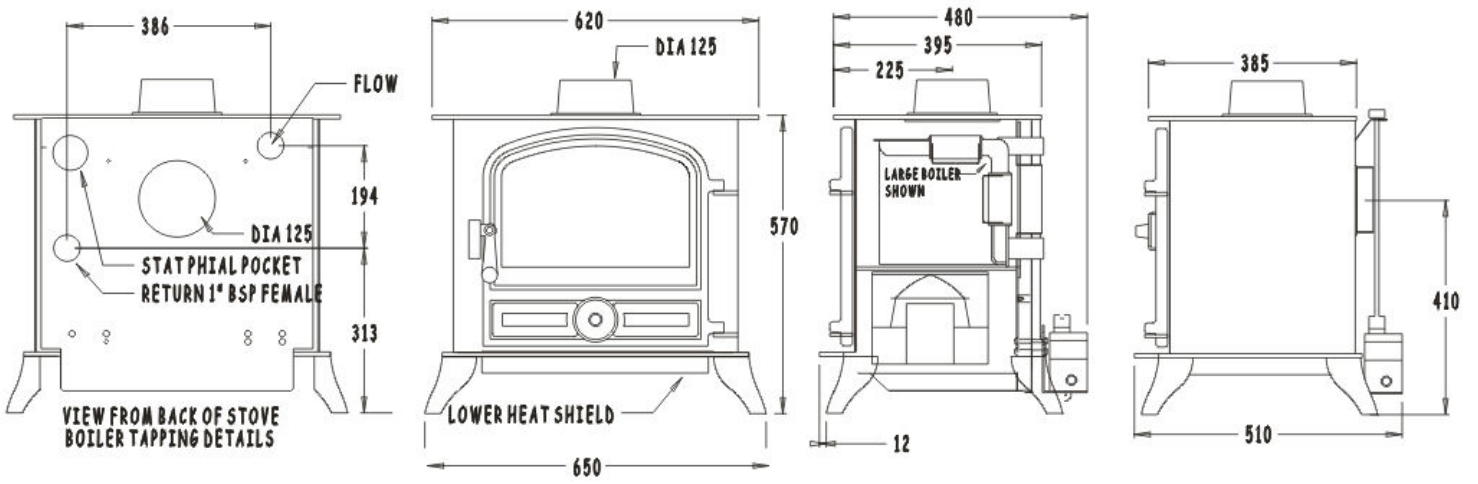

10-4 BACK CABIN COOKER DIMENSIONS

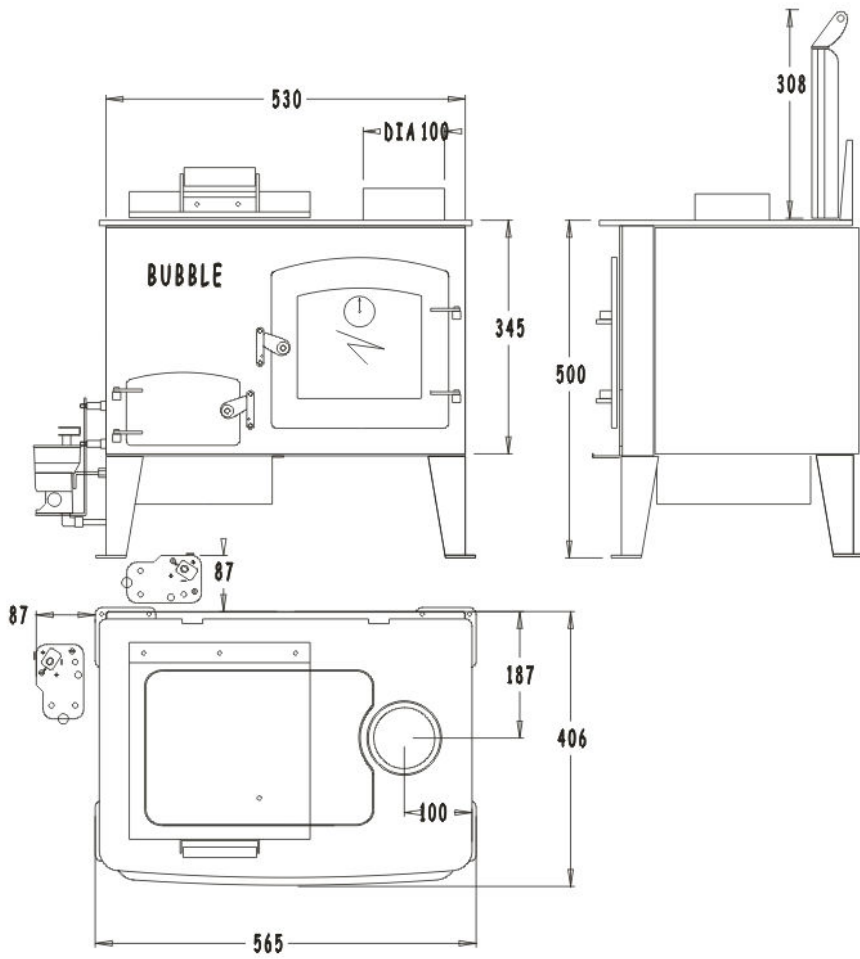

11. OIL CONSUMPTION RATES

		MAX HEAT OUTPUT TO WATER	MAX HEAT OUTPUT TO SPACE	MINIMUM OIL FLOW CC'S PER MIN	MAXIMUM OIL FLOW CC'S PER MINUTE
--	--	--------------------------	--------------------------	-------------------------------	----------------------------------

B1 HALF POD & OVEN DERIVATIVE					
Free Standing	From 1.6kW to 5kW		5kW	4 = (1.6kW)	12 = (5kW)
Free Standing	From 1.6kW to 5kW	2kW	3kW	4 = (1.6kW)	12 = (5kW)
Free Standing	From 1.6kW to 6kW	5kW	2kW	4 = (1.6kW)	13 = (6kW)

CORNER STOVE & OVEN DERIVATIVE					
Free Standing	From 1kW to 4kW		4kW	3 = (1kW)	10 = (4kW)
Free Standing	From 1kW to 4kW	3kW	1kW	3 = (1kW)	10 = (4kW)

BUBBLE 2					
Free Standing	From 1.6kW to 5kW		5kW	4 = (1.6kW)	13 = (5kW)
Free Standing	From 1.6kW to 8kW		8kW	4 = (1.6kW)	16 = (8kW)
Free Standing	From 1.6kW to 8kW	3kW	5kW	4 = (1.6kW)	16 = (8kW)
Free Standing	From 1.6kW to 8kW	9kW	2kW	4 = (1.6kW)	22 = (11kW)

BACK CABIN COOKER					
Free Standing	From 1.6kW to 5kW		3kW	4 = (1.6kW)	7 = (3kW)
Free Standing	From 1.6kW to 5kW	1kW	2kW	4 = (1.6kW)	7 = (3kW)

© HARWORTH HEATING LTD 30.6.98

This publication may not be copied by any means, without written permission from the authors.

These products are subject to continuous development and improvement and it is consequently acknowledged that due to this process there may be some omissions and errors.

This publication is intended only to assist the reader in the use of this product and therefore Harworth Heating Ltd shall not be liable for any loss or damage whatsoever arising from the use of any information, error or omission found in this publication.

The appliances mentioned in this publication can only be installed and serviced by approved personnel.

Approved personnel means that they must HAVE BEEN SUITABLY TRAINED, if there are any

reliability issues reported back to **Harworth Heating** or **Bubble Products**, the installing engineer will be responsible for carrying out any rectification work.

For details of suitable training courses contact: - www.oftec.org

12. NORMATIVE REFERENCES

Boat installation work comes under the control of: -
The Boat Safety Scheme.

This scheme provides statutory requirements and associated EN / BS Standards for most aspects of installation work on boats.

Further information and a copy of the requirements can be obtained from:-

www.boatsafetyScheme.com

Where guidance for oil fired appliances is not readily available from the Boat safety Scheme publication, we then point out a list of standards which pertain to domestic installations and which are generally covered by the latest version of the English Building Regulations Doc J.

When read in conjunction with:-

1. Our installation instructions.
2. The Boat Safety Scheme rules.
3. The other standards detailed, enough information should be provided to allow for a safe installation.

BS 5440	Flues.
BS 6999	Flues
BS 7840	Fuel Hoses.
BS EN1057	Copper Tubes.
BS1344 Part 3 1988 ISO8290 1987	Flues.
BS EN 1443:2003	Chimneys - General requirements.
BS EN1856 part 1 replacing BS 4543	Flues.
BS EN1856 part 2 & BS 715 1993	Flues.
BS 1945: 1971	Stove door
BS EN 10296-1	Steel tubes
BS ISO 10088:2001	
BS EN ISO 9094-2003	
BS EN 10297-1	Steel tubes
BS EN 13384-1	Chimneys
BS EN 10088-1:2005	Stainless steels - Part 1: List of stainless steels

INSTALLATION & GENERAL INSTRUCTIONS



Silent Simplicity just for you!

MARINE OIL STOVES ©

ISSUE 15 @ 22-06-18

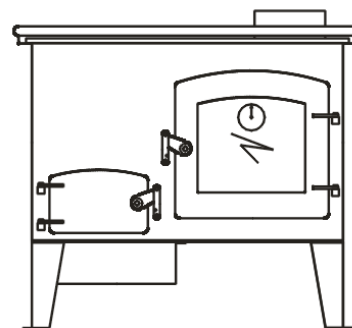
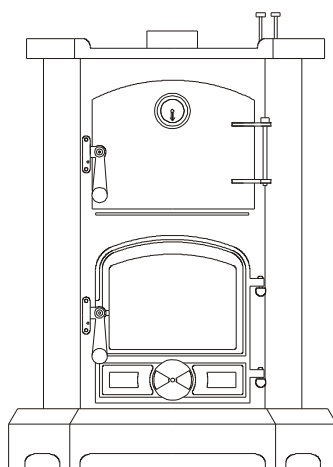
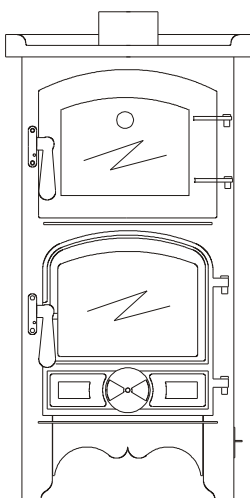
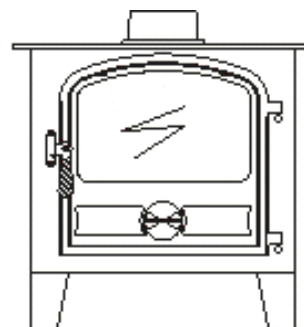
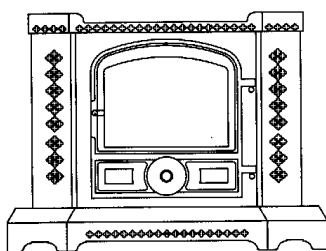
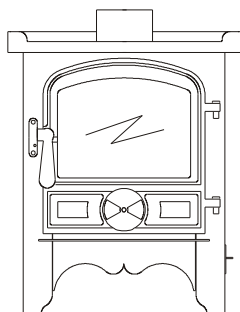

www.harworthheating.co.uk

INDEX

1. BEFORE STARTING THE JOB.	3
FITTING OPTIONS.	3
ABOUT THE APPLIANCES	3
2. SAFETY.	4
FUMES	4
FIRE	4
BURNS	4
CLEARANCES FROM COMBUSTIBLES	4
CLEARANCES FROM COMBUSTIBLES-FLUE PIPES	5
VENTILATION.	5
FLOODED VAPOURIZING BURNER POTS.	5
SECURELY FIX THE APPLIANCE	5
3. CHIMNEY	5
THE HEIGHT.	5
THE DIAMETER.	5
THE TEMPERATURE OF THE GASSES IN IT.	5
THE RESISTANCE OF THE INNER SURFACE OF THE FLUE PIPE OR PIPES.	5
THE TYPE OF TERMINAL.	5
THE PREVAILING ATMOSPHERIC CONDITIONS.	5
THE CHIMNEY RULES.	6
4. FUEL SUPPLY.	6
WAXING	6
AIR LOCKS	6
TRIM	6
TANK	6
OIL LINE	6
WATER CONTAMINATION	6
REMOTE SENSING FIREVALVES	7
ISOLATION VALVES.	7
SLEEVING.	7
OVERBOIL OR OVERHEAT PROTECTION OF THE APPLIANCE.	7
4A LIGHTING & COMMISSIONING	7
1. LIGHTING B1 HALF POD, B1 PIE POD AND B2	7
COMMISSIONING THE HIGH & LOW FIRE, CHRYSTAL SERIES	8
4B LIGHTING & COMMISSIONING THE BURNER SOCOMEF SERIES	9
1. LIGHTING CORNER STOVE, CORNER POD AND BACK CABIN COOKER.	9
COMMISSIONING THE HIGH AND LOW FIRE SOCOMEF BURNERS.	10
5. FIREPLACE.	10
6. DISTANCES FROM COMBUSTIBLES (APPLIANCES)	11
7. DISTANCES FROM NON COMBUSTIBLES (APPLIANCES)	11
8. DISTANCES FROM COMBUSTIBLES (FLUE PIPES)	11
9. ILLUSTRATIONS	12
FIG 1. STOVE DISTANCE FROM COMBUSTIBLES	12
FIG 2 BUBBLE MK1 FABRICATED DECK FLANGE LAYOUT	12
FIG 3 TYPICAL OIL FEED LAYOUT	13
FIG 4 TYPICAL PUMBING LAYOUTS	13
10. STOVE DIMENSIONS	14
10-1 BB1 HALF POD AND PIE POD DIMENSIONS	14
10-2 CORNER STOVE AND CORNER PIE POD DIMENSIONS	15
10-3 B2 STOVE DIMENSIONS	15
10-4 BACK CABIN COOKER DIMENSIONS	16
12. NORMATIVE REFERENCES	18

If you have any difficulties please phone our technical help line on-:

01302 742520 fax 01302 750573

e-mail contact@bubbleproducts.co.uk

<http://www.bubbleproducts.co.uk>

1. BEFORE STARTING THE JOB.

THE FOLLOWING NOTES PROVIDE INFORMATION FOR INSTALLATION OF THE FOLLOWING APPLIANCES.

Boat Bubble No 1 AND HALF POD, Dry Small and Large Boiler Appliances

Boat Bubble No 2 Dry Small and Large Boiler Appliances

Marine Corner Bubble Wet and Dry appliances

Bubble No 1 Cooking Stove plus boiler options.

Corner Cooking Stove plus boiler options.

Back Cabin Oil Fired Cooker.

FITTING OPTIONS.

There are normally two different situations that the installer may be faced with:-

1. A new build installation.

An established boat installation, (which has not had oil stove fitted).

2. A replacement installation, where there has been a solid fuel stove fitted previously.

Each of the situations will present differing problems which will be:-

- Where to locate the stove.
- How to deal with fireplace design.
- Where to locate the oil tank.
- How to get an oil supply to the stove.
- How to fit the chimney.
- How to connect water to the stove.
- How to disconnect and remove the stove, easily.

The new build situation should be the easiest.

The established boat situation will require careful attention to the sighting of the stove in relation to flue positions and existing fittings positions.

In replacement situations it may well be necessary to blank off the existing through roof flue position and cut a fresh one to suit the new location and comply with our instructions on flue design.

ABOUT THE APPLIANCES

Generally described as a space heater or space heater and cooker, which burns diesel oil in a controlled

manner utilizing a chimney to discharge the products of combustion.

The appliance generates heat from burning oil mixed with air in a vaporizing pot located in the bottom of the stove.

Once the appliance has been ignited, oil goes into the pot at a steady and controlled rate via a gravity feed which is metered by the OIL CONTROL VALVE; the oil flow can be controlled from minimum to maximum or any setting in between determined by the set position of the oil flow control knob.

Air is sucked into the pot by the natural action of the negative pressure in the chimney.

To allow the chimney to work correctly it is essential that you have adequate, unrestricted ventilation into the area where the stove is situated.

The amount of oil that can be successfully burned is directly proportional to the amount of air that the chimney can draw into the pot and so to achieve adequate combustion a balanced and appropriate flow of both oil and air is required.

The stove will provide space or combined space and water heating and in some cases cooking as well.

Where cooking and water heating are combined one feature will inevitably effect the other.

There are different versions of each appliance within the total range.

Some of the appliances are supplied as Dry, Small Boiler and Large Boiler versions namely B1 Half Pod, B1 Oven and B2.

Some of the appliances are supplied just as Dry and Large Boiler versions namely Corner Stove and Corner Oven Stove.

The Back Cabin Cooker can be supplied with or without a small boiler for domestic hot water heating only.(1kw)

All of the boilers are high water content and suitable for pumped or gravity systems and pressurised or open vented systems ASSUMING THAT THEY ARE INSTALLED BY SUITABLY QUALIFIED PERSONS.

All the appliances are fitted with a descaling device which should be rotated on a two weekly cycle to descale the oil inlet pipe.

Where applicable, appliances must not be operated with the glass front door opened or cracked, or without the lighting port plug fitted.

Where applicable, the door glass may require light cleaning occasionally depending upon the continuous running time of the stove.

Appliances must be securely bolted down to resist impact or collision and must be level in both directions.

All the appliances are supplied with clamp down brackets except the Back Cabin Cooker which must be fastened down through the foot plates.

The top of the appliances can be used for warming and cooking.

The oven appliances have a comprehensive range of cooking facilities with both oven and hot plate cooking available.

Some appliances can also be supplied with a coal kit, which just like a solid fuel stove, coal effect will only be available when the stove is running at maximum or near maximum performance.

Suitable deck flanges, flue systems and anti-downdraft cowls must be used.

CONTROLS

The output of the stove is regulated by the amount of oil allowed to go into it and this function is controlled by the -:

OIL CONTROL VALVE (O.C.V.), Turning the knob anti clockwise controls the oil flow.

2. SAFETY.

Take care to make sure that all safety and ventilation issues are adequately addressed.

FUMES

Always fit a suitable Smoke and Carbon Monoxide alarm within 1.5meters of the appliance.

Make sure that the function is checked on regular basis. (weekly)

Make sure that the alarm can be heard in the sleeping quarters.

Here are the main causes of fume or smoke to leak from the stove.

- The chimney is blocked.
- There are too many bends in the chimney.
- The above deck chimney extension is not high enough.
- The boat is moored in a position near to high buildings or trees and downdraughting is occurring.
- The chimney or parts of it are not airtight.

- There are unusually strong cross winds.

If down draughting occurs turn the appliance off until the winds subside and do not attempt to re-ignite the appliance until it has completely cooled down.

When it has cooled down, before attempting to ignite the appliance remove the catalyser and examine the base of the pot to make sure that there is no oil left in the pot, if there are signs of oil in the pot do not attempt to ignite the appliance until it has been completely dried out.

FIRE

Fire can be caused by a variety of potential danger points and because of the space limitation on boats; this risk is ever present and must be adequately assessed.

The main danger is the effects of heat from the stove on combustible materials and boat occupants.

Make sure that all combustibles are adequately protected from the effects of heat radiation.

Appliances must stand on a fireproof base of minimum thickness 30mm or a purpose made stand.

Floors in front of the stove must have suitable fire protection.

Built in stove heat shields should not be removed under any circumstances.

BURNS

During normal, day-to-day use, many parts of the stove, pipe work, and chimney will become too hot to touch.

Hot surfaces must be adequately protected to prevent anyone falling on to, or touching them.

Suitable fireguards for the appliance and chimney must be fitted.

Fireguards must comply with BS6539.

Always use heatproof gloves when working on or near to a hot stove.

CLEARANCES FROM COMBUSTIBLES

The appliances must be fitted in line with the distances specified in the tables.

All hearths and fireplaces must be made from non-combustible materials and adequately designed for the job.

CLEARANCES FROM COMBUSTIBLES-FLUE PIPES

Flue pipes must be fitted in line with the distances specified in the table and must be suitable for the individual application.

Any combustible materials within the specified distances from the appliances must be protected by a suitable heat shield.

Protection can be gained by the use of -:

- Sheet metal heat shields and spacers.
- Heat resistant boards such as TAC board.
Combustible materials can be-:
- Wooden furniture.
- Curtains.
- Wooden panels or frames adjacent to the flue pipe or where it passes through the deck of the boat.
- Carpet or flooring close to the stove.
- Items near to the stove, which could fall onto it and ignite, should the boat suffer a slight impact or collision.

VENTILATION.

Ventilation plays a vital role in the fitting and sighting of any stove.

The provision of ventilation for these appliances is adequately covered by the requirements of the boat safety scheme.

25cm sq. minimum permanent ventilation, directly to outside air, must be provided.

FLOODED VAPOURIZING BURNER POTS.

When attempting to light any of the appliances, make sure that the pot is not flooded with oil by looking into the base of the burner.

If it is flooded remove the excess oil.

Never try to relight a hot stove; wait until it has cooled down.

Hot oil vapour is explosive.

Never try to light a flooded pot.

SECURELY FIX THE APPLIANCE

The stove must be securely fastened down so that it can resist impact or collision and it must be level in both directions.

Level the stove in both directions when the vessel is midway between its maximum and minimum trim conditions.

Bubble appliances must not be fitted if the maximum angle of trim exceeds 0.75 deg forward to aft or port to starboard.

Only suitably qualified persons can install unvented plumbing systems.

A suitable and serviceable fire extinguisher should always be readily accessible.

3. CHIMNEY

This is the one of the most interesting problems the installer has to deal with and as the chimney affects most aspects of running the stove, we take time here to list the following information for your consideration.

The power, (*suck or vacuum the chimney can develop*) depends upon the following-:

THE HEIGHT.

THE DIAMETER.

THE TEMPERATURE OF THE GASSES IN IT.

THE RESISTANCE OF THE INNER SURFACE OF THE FLUE PIPE OR PIPES.

THE TYPE OF TERMINAL.

THE PREVAILING ATMOSPHERIC CONDITIONS.

It is obvious that on a boat all the above elements are in short supply.

Normally, we have low flues which are small in diameter and generally not very well insulated, coupled with all these problems we have another one, which is that the boat moves across constantly changing surroundings, through locks, into headwinds and crosswinds, all creating major opportunity for down draughting to occur.

Any bend in any part of the chimney or roughness on the internal chimney wall will slow down the velocity of rising gases and reduce the effectiveness of the chimney.

Any slight reduction in the flue gas temperature will reduce the chimney vacuum or pull, hence when the stove is slowed down for all night burning, as the flue gas cools down the chimney vacuum reduces and as the chimney vacuum drops, the stove may well start to burn sooty. This problem is highlighted even more during very cold weather when the chimney can cool down even faster. In these situations careful attention to servicing and low fire setting is essential.

THE CHIMNEY RULES.

1. Always use a top outlet for flue pipe take off.
2. Always try to get the stove as low as possible in the boat, this will allow installation of maximum length flue pipe.
3. Clean or have the chimney cleaned regularly. (Frequency depends upon type of fuel and length of time used).

4. FUEL SUPPLY.

There are several problems relating to diesel fuel supply, which need be adequately addressed.

WAXING

Cold weather waxing or thickening alters the flow characteristics of diesel.

An adequate fuel feed supply can turn into an inadequate one when the temperature starts to fall.

The worst scenario is fuel feed pipe 50-60 feet long in 8mm dia pipe.

The best-case scenario is a fuel pipe 4 feet long in 10mm dia with insulated lagging.

AIR LOCKS

Air lock in oil feed pipe work must be avoided.

The pipe work must slope down to the appliance and be clipped level at 500mm intervals to prevent sagging.

Any rises in the pipe work will cause air locks on commissioning and after future oil run out situations, if it is not possible to run the pipe work in a steady slope then where changes occur a vertical venting leg should be fitted.

TRIM

Bubble appliances must not be fitted if the maximum angle of trim exceeds 0.75 deg forward to aft or port to starboard.

Level the stove in both directions when the vessel is midway between its maximum and minimum trim conditions.

A minimum pressure head of 254mm (10") is required.

This head is measured from the base of the oil tank to the top of the oil control valve. In some cases this head can be affected by the ballast or trim of the boat.

Take great care to try out all the different ballast and trim possibilities to make sure that adequate oil feed is always available at the outlet end of the fuel pipe before it enters the oil control valve at the stove.

TANK

If the stove is fitted at the bow of the boat, a bow tank is recommended.

The tank should comply with the requirements of the boat safety scheme and have:-

- A conveniently sized filler
- A means of venting.
- A conveniently located, easily visible, contents gauge.
- An isolation valve
- An easily replaceable cartridge filter.
- A suitable and substantial water trap

Do not use glass filter bowls, they are not acceptable under the boat safety scheme.

Make sure that you fuel supplier supplies you with appropriate fuel for wintertime running.

OIL LINE

The oil feed line starts after the fuel filter and proceeds to the point of entry, which is where the oil line goes into the cab or saloon of the boat.

The diameter of the oil line is dependent upon the length of run. See 3-2 on waxing and make sure that you have suitably sized compression fittings available.

At this point it is necessary to fit a 60 DEG C, remote sensing fire valve, designed to shut off the oil supply, should a fire occur near to the stove.

If the bubble stove is fitted up to the first bulkhead it will be necessary to fit the isolation valve outside the cabin or saloon of the boat. 5. Make sure that you have purged the oil feed line of all air and there is a steady and constant flow of oil available at the inlet to the oil valve. Make sure that all or any oil isolation devices are turned to the on position. Remember that the oil valve needs a min head of 300mm for gravity feed. When feeding from rear tanks with appliances fitted forward always be aware of the forward - aft trim of the vessel.

Do not use syphonic oil feeds to Bubble Appliances, oil should be fed by gravity or pumped via an appropriate pressure pump = head pressure less than 99mbar.

WATER CONTAMINATION

Because of the high risk of fuel contamination with water, we strongly recommend the fitting of a **high volume water trap**, in the oil supply line.

REMOTE SENSING FIREVALVES

There are two situations where a remote sensing firevalve should be fitted.

1. For fire protection fit a 60 deg C valve.
2. For over boil protection fit an additional 90 deg C valve.

For fire protection a remote sensing fire valve should be fitted as detailed in fig 3.

Run the capillary tube with the oil line up to the stove and carefully fit the sensing phial as follows

B1 Half Pod, B1 Oven and B2 at a low level fitted on two 15mm pipe clips.

Corner Stove and Corner Oven Stove on 15mm pipe clips in front of the drip tray on the fireplace hearth, directly in front of the combustion air restrictor.

Before it is fitted try the fender on the stove to make sure that the fender does not foul the sensing phial.

The sensing phial may be visible through the bottom of the fender, to mask it, paint it with matt black paint available from our sales desk.

When fitting the fire valve make sure that where the capillary and oil line go through the bulkhead in separate sleeved tubes, so that the capillary can be withdrawn separately should it ever need replacing.

For fitting of long oil feed lines which pass through bulkheads and various other parts of the boat it may well be necessary to fit more than one fire valve, especially where the oil line passes through an area where a fire could occur i.e. kitchen area etc.

ISOLATION VALVES.

Two isolation valves are required, one fitted directly into or close to the oil control valve to allow you or the service man to turn the oil off should the need arise, and one fitted directly into the oil tank before the fuel filter.

Always turn off the oil isolation valve serving the appliance before leaving the vessel unattended.

SLEEVING.

Where the oil line goes through the boat superstructure a suitable bulkhead fitting must be used.

OVERBOIL OR OVERHEAT PROTECTION OF THE APPLIANCE.

Where appliances are not fitted with an automatic thermostat an additional 90 DEG C, remote sensing

fire valve must be fitted directly in front of the oil control valve and the sensor from this valve has to be attached to the water jacket or the hot outlet pipe from the boiler.

The valve is calibrated to shut the oil supply down should the water temperature exceed 90 Deg C.

There is a re set button on the remote sensing fire valve which needs to be pressed in to re set the valve after it has tripped off.

4A LIGHTING & COMMISSIONING

A relevant oil control valve catalogue is supplied with each appliance and details of high and low fire adjusting screws are illustrated.

On the Toby valve the low fire screw is clearly visible as per TOBY MANUAL FIG 2

Before trying to light the burner in cold weather it is advisable to pre heat the flue pipe before lighting.

There are two different types of burner fitted to Bubble appliances.

The FB style burner fitted to the **B1 Half Pod, B1 Pie Pod and B2.**

The Socomef burner fitted to the **Corner Stove, Corner Oven Stove** and the **Back Cabin Cooker see sec 4B for lighting Socomef burners.**

1. LIGHTING B1 HALF POD, B1 PIE POD AND B2

When attempting to light the stove these are the rules, which must be followed.

1. Always make sure that the pot is **not** flooded with oil by looking down into the base of the pot.
2. Never try to light the stove if it is flooded with oil.
3. Always check that oil has not leaked from the appliance.
4. Do not light the stove and leave it unattended until it is settled down and stabilized into constant blue flame combustion on low fire. (This could take 10 to 20 minutes.)

On first light up it is advisable to warm the flue pipe up to try and create chimney draft.

Two Ways to Light the Stove

1. Through the lighting port B1 and B2 appliances only,
or
2. Directly into the base of the pot by removing the catalyser.

Lighting into the base of the Pot

On the first light up you may find this option better, as it is possible to see the oil trickle in to the pot more easily.

Use a heatproof glove when putting the catalysers back into the pot and it is important to replace them quickly whilst the flame is small.

Make sure that the oil is turned off.

Open the front door.

Remove the optional coal kit if fitted.

Remove the catalyser.

Turn the oil on and allow a small pool of oil to flow into the pot about the size of a small biscuit, **then turn the oil off.**

Note that on first light up it may take a few minutes for the oil to reach the pot as it has to fill the pipework before reaching the pot, take care not to allow excess oil to flow into the pot.

Light a small piece of firelighter and drop it into the oil, allow a few seconds for it to get going and then replace the catalyser and coal kit if fitted, and close the door.

Wait for approx. 1 minute until the pool of oil is alight and then **turn the oil on** to minimum setting no 1.

Watch the appliance for a few minutes and you will see the flame establish and settle down into blue flame combustion.

Allow the burner to run for a further 10 minutes before turning the appliance up to the higher settings.

If at any time during the ignition process large amounts of flame can be seen, turn the oil off immediately and wait until the flames die down before putting the oil on again at minimum setting.

Manual Lighting through the Lighting Port B1 and B2 appliances.

Check that the isolation valve is turned on.

Open the front door.

Remove the front apron on B1 Half Pod and B1 pie Pod.

Remove the lighting port plug by pulling it out of its tubular socket.

Turn the oil on to the first position via the flow control knob and allow a small pool of oil to flow into the pot about the size of a small biscuit.

Turn the oil off.

Cut a small piece of firelighter and stab it onto the spike.

Light it and push it into the lighting port tube, let the firelighter drop off the spike into the bottom of the pot.

Replace the lighting port plug back into the tube.

Close the front door.

Turn the fuel flow on again at the lowest setting

Watch the appliance for a few minutes until it settles down into blue flame combustion.

Allow the burner to run for a further 10 minutes before turning the appliance up to the higher settings.

If at any time during the ignition process large amounts of flame can be seen, turn the oil off immediately and wait until they die down before putting the oil on again.

Note there may be the occasional growl or audible vibration whilst the burner settles down into blue flame combustion.

COMMISSIONING THE HIGH & LOW FIRE, CHRYSTAL SERIES

Used in B1 Half Pod, B1 Pie Pod and B2

When the burner has established good blue flame combustion turn it up to half output. (Setting 3 on the fuel flow control knob) and let it stabilize.

Allow at least half an hour for the chimney to warm up thoroughly before making any adjustments to the high or low fire screws.

Turn the stove down onto minimum firing rate and let it stabilize.

After stabilization there should be a dull red glow in the lower catalyser with wispy blue flames flicking into and just over it.

If the flame falls into a dirty rolling yellow flame and the catalyser is not dull red then the low fire will need to be increased until it can support the required blue flame combustion.

To increase the low fire oil flow, screw the adjusting screw out by quarter turn increments.

When you are happy with the low fire, set the high fire.

Turn the oil flow knob up to setting 4, let the flame stabilize, and look at it, if it is stable and blue, turn it up slowly using the control knob, letting it stabilize after each movement, if the flame starts to go yellow with long flame combustion, it is running fuel rich and

the high fire screw needs adjusting to reduce the flow of oil. (Screw the adjuster screw in to reduce the high fire oil flow.)

Before adjusting the high fire screw, turn the flame down and let it stabilize in blue flame combustion, adjust the high fire screw by half a turn in and try turning the fuel flow up, if it is still fuel rich repeat the process until the high fire flame is running blue with just flicks of yellow in the tips.

To see a bubble stove running correctly see the following link

<https://www.youtube.com/watch?v=UqdQLFp3HkQ>

4B LIGHTING & COMMISSIONING THE BURNER SOCOMEF SERIES

1. LIGHTING CORNER STOVE, CORNER POD AND BACK CABIN COOKER.

When attempting to light the stove these are the rules, which must be followed.

1. Always make sure that the pot is not flooded with oil by looking down into the base of the pot.
2. Never try to light the stove if it is flooded with oil.
3. Always check that oil has not leaked from the appliance.
4. Do not light the stove and leave it unattended until it is settled down and stabilized into constant blue flame combustion on low fire. (This could take 10 to 20 minutes.)
5. Make sure that you have purged the oil feed line of all air and there is a steady and constant flow of oil available at the inlet to the oil valve. Make sure that all or any oil isolation devices are turned to the on position. Remember that the oil valve needs a min head of 300mm for gravity feed. When feeding from rear tanks with appliances fitted forward always be aware of the forward - aft trim of the vessel.
6. Do not use syphonic oil feeds to Bubble Appliances, oil should be fed by gravity or pumped via an appropriate pressure pump = head pressure less than 99mbar.

On first light up it is advisable to warm the flue pipe up to try and create chimney draft.

Lighting the Stove

Lighting the stove takes a little time and patience; the following procedure should be adopted.

In the case of the Corner appliances, open the front door and in the case of the Back Cabin Cooker remove the hot plate and top baffle to gain access to the

burner, note that the back cabin cooker has a lighting port fitted behind the lower ash pit door.

Remove the coal kit if it has been supplied with the stove.

Lift the inner mesh catalyser from the burner.



Look into the bottom of the pot and turn the oil on at full rate, allow oil to flow into the bottom of the pot to form a pool about the size of a small digestive biscuit and then turn the oil off.

Note that on first light up it may take a few minutes for the oil to reach the pot as it has to fill the pipework before reaching the pot.

Do not allow any depth of oil to build up.

Light a small piece of firelighter (about the size of a pineapple chunk) and place it into the centre of the oil pool.

Replace the mesh catalyser and the coal kit, if fitted and then leave the door slightly open whilst the firelighter gets the oil going.

After 30 to 40 seconds, you will notice the flame start to establish itself and spread around the bottom of the pot.

When this occurs, close the door or replace the baffle and top plate and then turn the oil on to its minimum setting.

After two or three minutes the flame should slowly change from yellow into blue flame combustion and settle down to a steady burn.

Note there may be the occasional growl or audible vibration whilst the burner settles down into blue flame combustion.

Allow the burner 10 - 15 minutes to stabilise and the increase the flow of oil as required, moving by one increment of the dial only.

Do not leave the appliance unattended during the lighting and stabilising procedure.

COMMISSIONING THE HIGH AND LOW FIRE SOCOMEF BURNERS.

Corner Stove, Corner Pod and Back Cabin Cooker.

Note that Back cabin Cookers are pre commissioned at the factory and do not need adjusting.

A relevant oil control valve catalogue is supplied with each appliance and details of high and low fire adjusting screws are illustrated.

On the Toby valve the low fire screw is clearly visible as per TOBY MANUAL FIG 2

When the burner has established good blue flame combustion turn it up to half output. (Setting 3 on the fuel flow control knob) and let it stabilize for a minute. Allow at least half an hour for the chimney to warm up thoroughly before making any adjustments to the high or low fire screws.

Turn the stove down onto minimum firing rate and again let it stabilize.

After stabilization there should be a dull red glow in the catalyser with wispy blue flames flickering just over the top of it, approximately level with the top of the pot.

If the flame falls into a dirty rolling yellow flame and the catalyser is not dull red then the low fire will need to be increased until the burner can support the required blue flame combustion.

When you are happy with the low fire, set the high fire.

Turn the oil flow knob up to setting 4, let the flame stabilize, and look at it, if it is stable and blue, turn it up slowly using the control knob, letting it stabilize after each movement, if the flame starts to go yellow with long flame combustion, it is running fuel rich and the high fire screw needs adjusting to reduce the flow of oil. (Screw the adjuster screw in to reduce the high fire oil flow.)

Before adjusting the high fire screw, turn the flame down and let it stabilize in blue flame combustion, adjust the high fire screw by half a turn in and try turning the fuel flow up, if it is still fuel rich repeat the process until the high fire flame is running blue with flicks of yellow in the tips.

On the Socomef pot, the high fire flame will be set approx. 40mm above the top of the pot.

NOTE THAT THIS PROCEDURE WILL NOT BE POSSIBLE IF THE CHIMNEY RULES HAVE NOT BEEN ADHERED TO.

THE HIGH FIRE SETTING WILL HAVE TO BE ADJUSTED IN LINE WITH THE AVAILABLE GENERATED CHIMNEY VACUUM IE

THE FLUE PIPE MUST BE A MINIMUM OF 1.8 METERS HIGH FOR LOW FIRE AND 2.1 METERS FOR HIGH FIRE.

INSTALLING ENGINEERS SHOULD NOT LEAVE THE APPLIANCE UNDER THE CONTROL OF THE CUSTOMER UNLESS THE APPLIANCE HAS BEEN CORRECTLY COMMISSIONED.

TO SEE HOW THE BURNER SHOULD OPERATE COMMISSIONING AND INSTALLING ENGINEERS SHOULD VISIT

<https://www.youtube.com/watch?v=UqdQLFp3HkQ>

This video shows a stove running from low to high fire and back to low fire. Note that this video is filmed on a normal house chimney and so it may not be possible to get exactly the same conditions on a typical boat flue as the fuel air ratio will not be exactly the same, hence the need for fine tuning the oil flow to the chimney air flow capability.

5. FIREPLACE.

Unless one is built into the appliance, always fit appliances on a suitable drip tray.

The possibility of oil drops leaking from the stove must be considered; a suitable oil drip tray must be fitted and designed in such a way, as it will contain any oil leaks or drips.

Normally the tray will cover the footprint of the stove, the oil valve and isolation device.

It will be oil tight and have a vertical up stand of at least 30mm. This should give a minimum containment volume of 2 litres.

It will be securely fastened down to the vessel and the appliance must be securely fastened down to the oil drip tray.

Make sure that drip trays are tested to ensure that they do not leak when filled with oil.

The hearth must be:-

FLAT - SECURE - FIREPROOF AND LEVEL IN BOTH DIRECTIONS.

Use materials, which are easy to keep clean and fireproof such as tiles, asbestolux or vermiculite boarding with a suitable weight resistant liner.

The vertical walls of the fireplace must also be made from fireproof materials.

Use fireproof, rockwool infill behind the fireplace panels to protect any combustible insulation materials

such as spray foam.

6. DISTANCES FROM COMBUSTIBLES (APPLIANCES)

Stove Type	ABOVE	SIDES.	BACK	FRONT	HEARTH Non Combustible Material
B1 HALF POD and OVEN VERSION	500	300	150 FROM HEAT SHIELD	300 to allow door opening.	30MM THICK x 100 projection at the front and sides
BOAT B2	600	300	150 FROM HEAT SHIELD	300 to allow door opening.	30MM THICK x 100 projection at the front and sides
CORNER and OVEN VERSION	500	75	100 FROM HEAT SHIELD	300 to allow door opening.	30MM THICK x 100 projection at the front.
BACK CABIN COOKER	500	150	100 FROM HEAT SHIELD	300 to allow door opening.	25MM THICK x 150 projection at sides

7. DISTANCES FROM NON COMBUSTIBLES (APPLIANCES)

Stove Type	ABOVE	SIDES.	BACK	FRONT	HEARTH Non Combustible Material
B1 HALF POD and OVEN VERSION	300	150	150 FROM HEAT SHIELD	300 to allow door opening.	30MM THICK x 100 projection at the front and sides.
BOAT B2	300	150	150 FROM HEAT SHIELD	300 to allow door opening.	30MM THICK x 100 projection at the front and sides.
CORNER and OVEN VERSION	200	150	25 FROM HEAT SHIELD	300 to allow door opening.	30MM THICK x 100 projection at the front and sides.
BACK CABIN COOKER	500	75	50 FROM HEAT SHIELD	300 to allow door opening.	25MM THICK x 75 projection at sides

Note that the back cabin cooker can have the oil control valve fitted to the rear or the left hand side in each case the positioning of the valve will affect the fireplace and spacing considerations, see sizes of cooker to establish requirements.

8. DISTANCES FROM COMBUSTIBLES (FLUE PIPES)

For all appliances-:

1. **Single skin flue pipes.** Horizontal Distance = 50mm **when fitted within the deck flange** at the top of the chimney system, protected by the fire stop spacer.
2. **Single skin flue pipes.** Horizontal Distance = 150mm **when exposed in the saloon or living space.**
3. **Twin Wall Insulated flue pipes.** Horizontal Distance = 30 mm for insulated flue pipe systems.

9. ILLUSTRATIONS

FIG 1. STOVE DISTANCE FROM COMBUSTIBLES

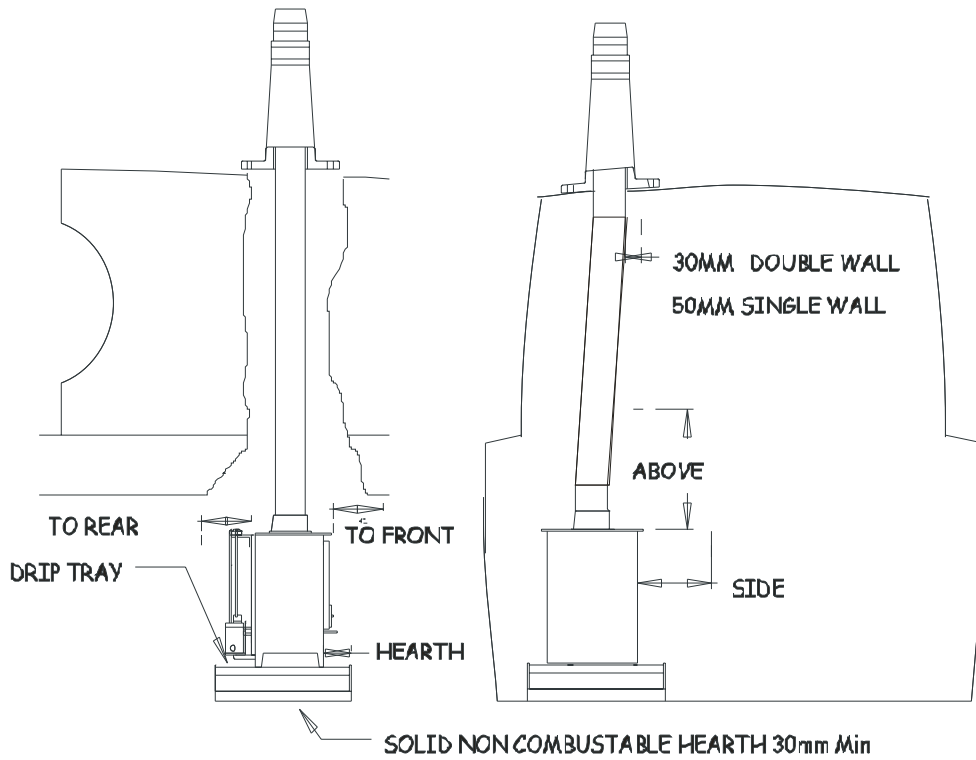

FIG 2 BUBBLE MK1 FABRICATED DECK FLANGE LAYOUT

Note that there is mk3 system which is now available and detailed on our web site.

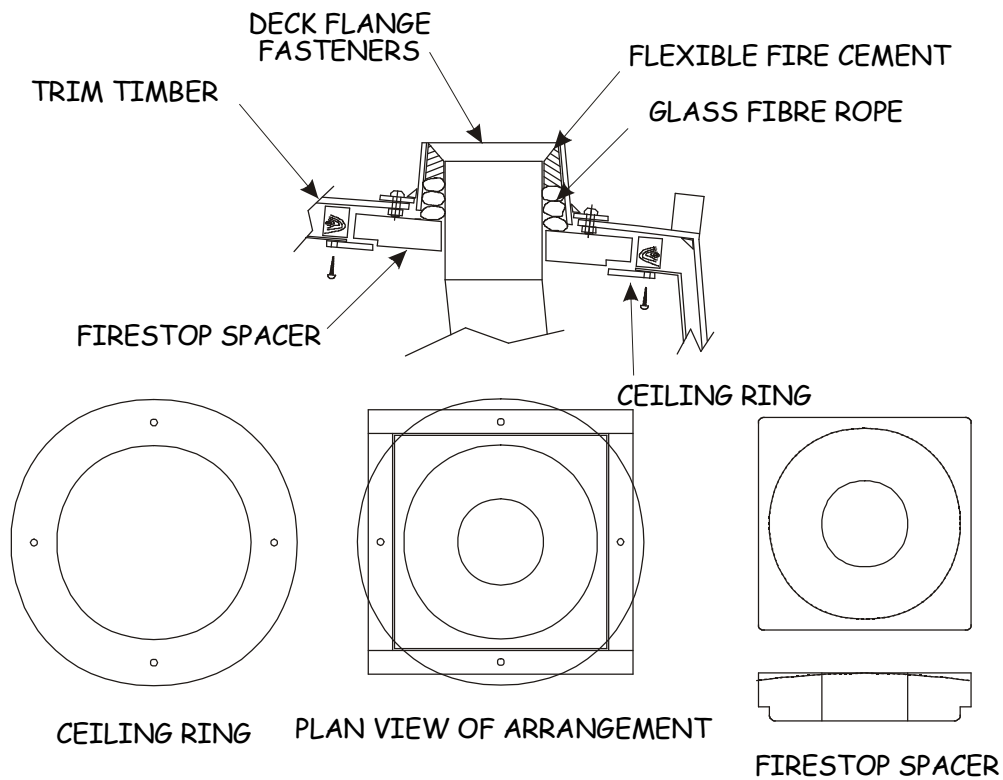
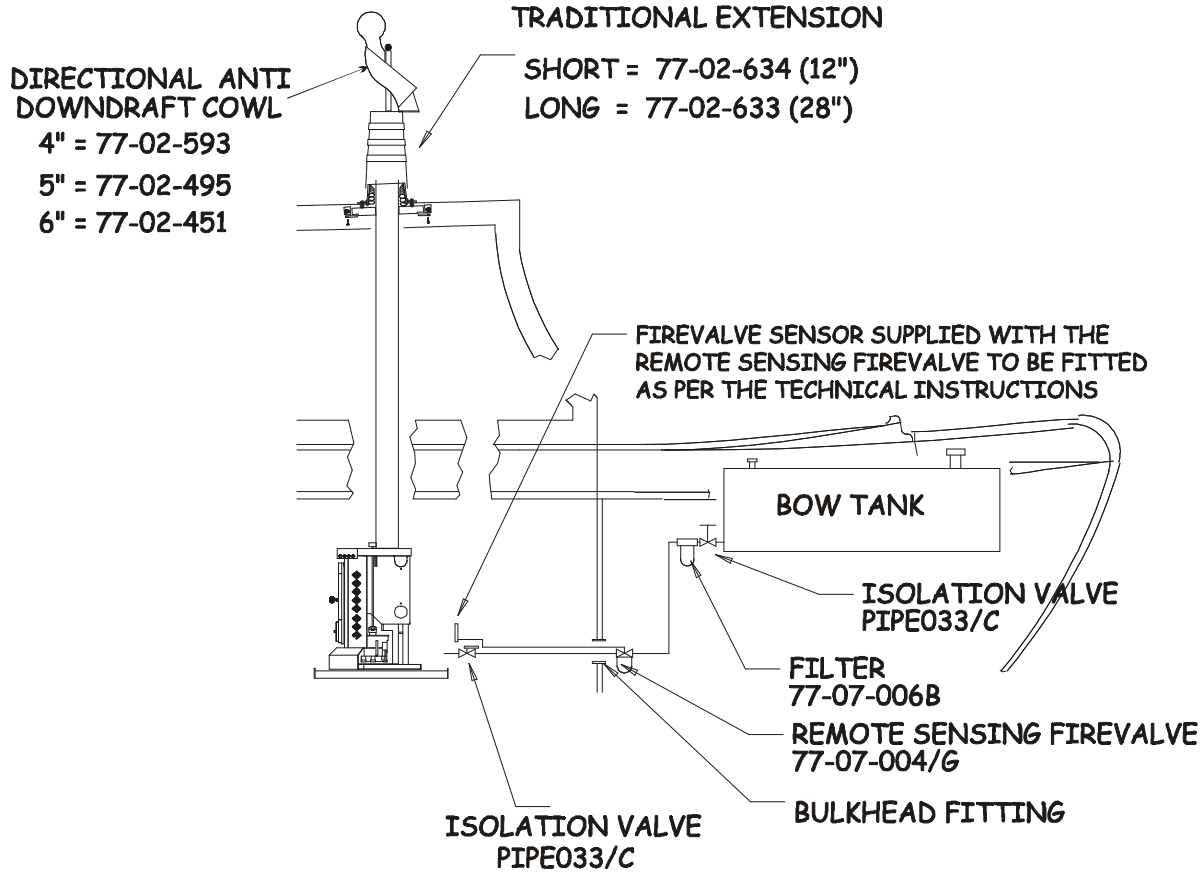

FIG 3 TYPICAL OIL FEED LAYOUT



COPYRIGHT HARWORTH HEATING LTD 080800

FIG 4 TYPICAL PUMING LAYOUTS

Drq 1

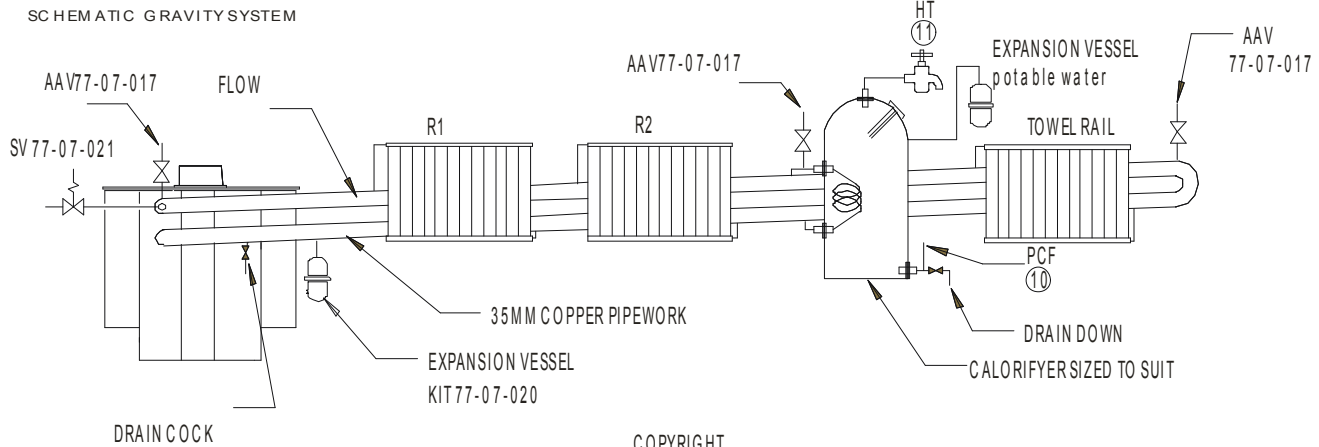

COPYRIGHT BUBBLE PRODUCTS 2013

Drg 2

SCHEMATIC PUMPED SYSTEM ISS 2 OF 28-10-17

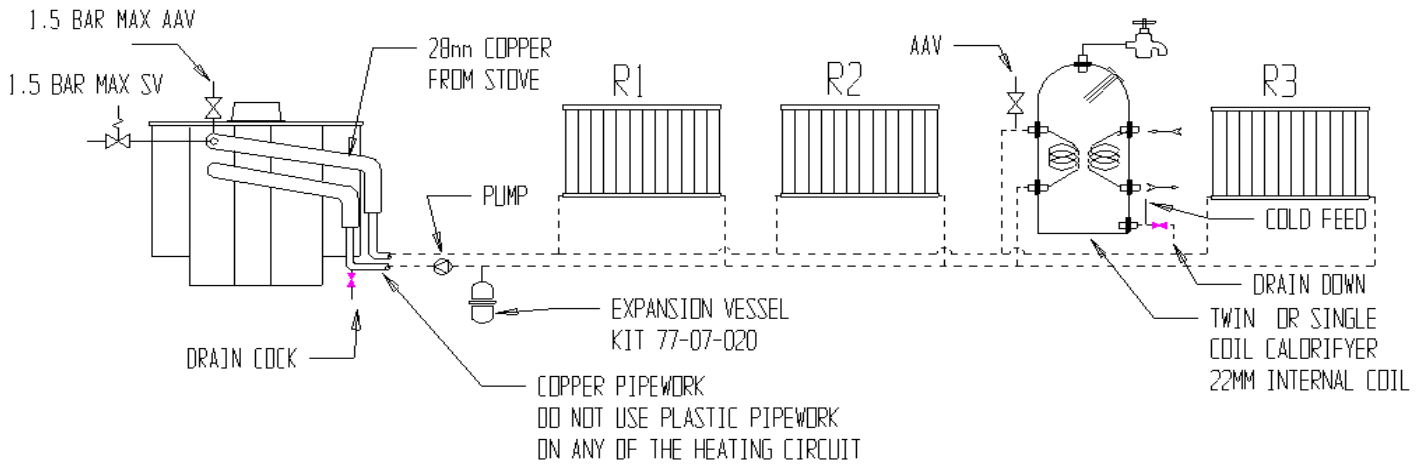

Drg 3

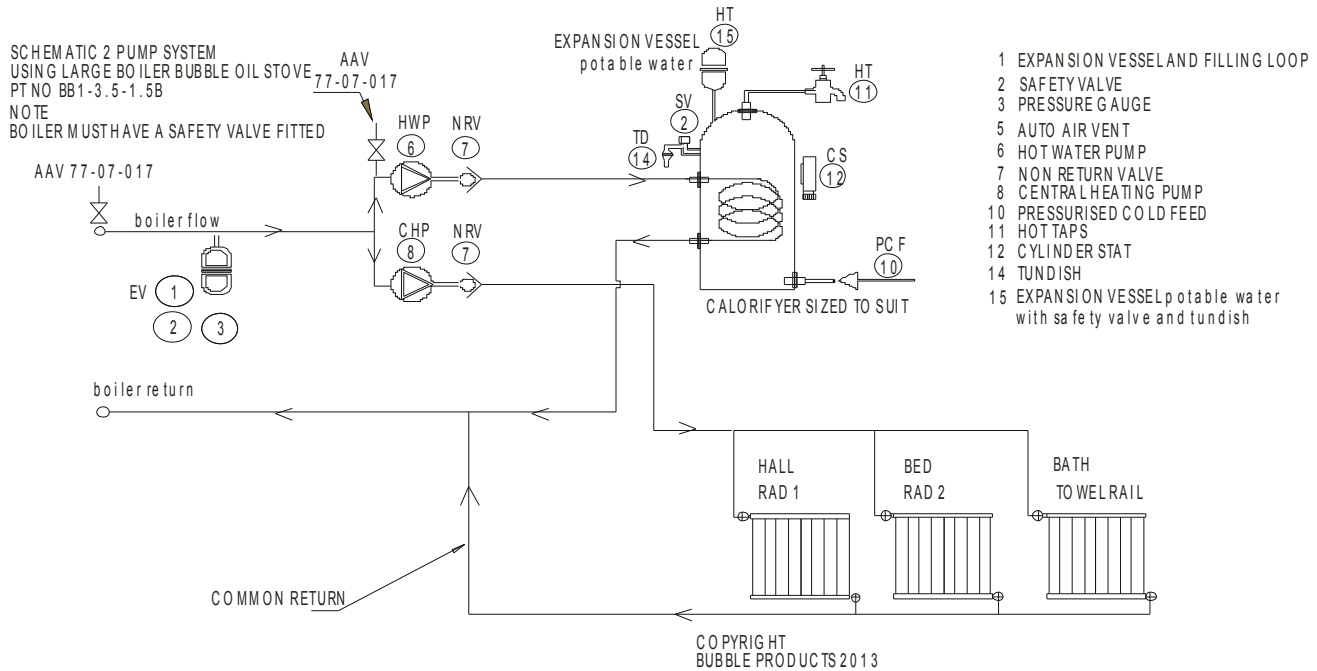

10. STOVE DIMENSIONS

10-1 BB1 HALF POD AND PIE POD DIMENSIONS

Note that the B1 Pie Pod has the same footprint dimensions but the vertical height is 830mm.

**B1 HALF OIL POD OF 12-02-15
OVERALL DIMENSIONS
BOILER AND NON BOILER VERSIONS**

**.WEIGHT 35 KG NON BOILER
.WEIGHT 45 KG SMALL BOILER
.WEIGHT 50 KG LARGE BOILER**

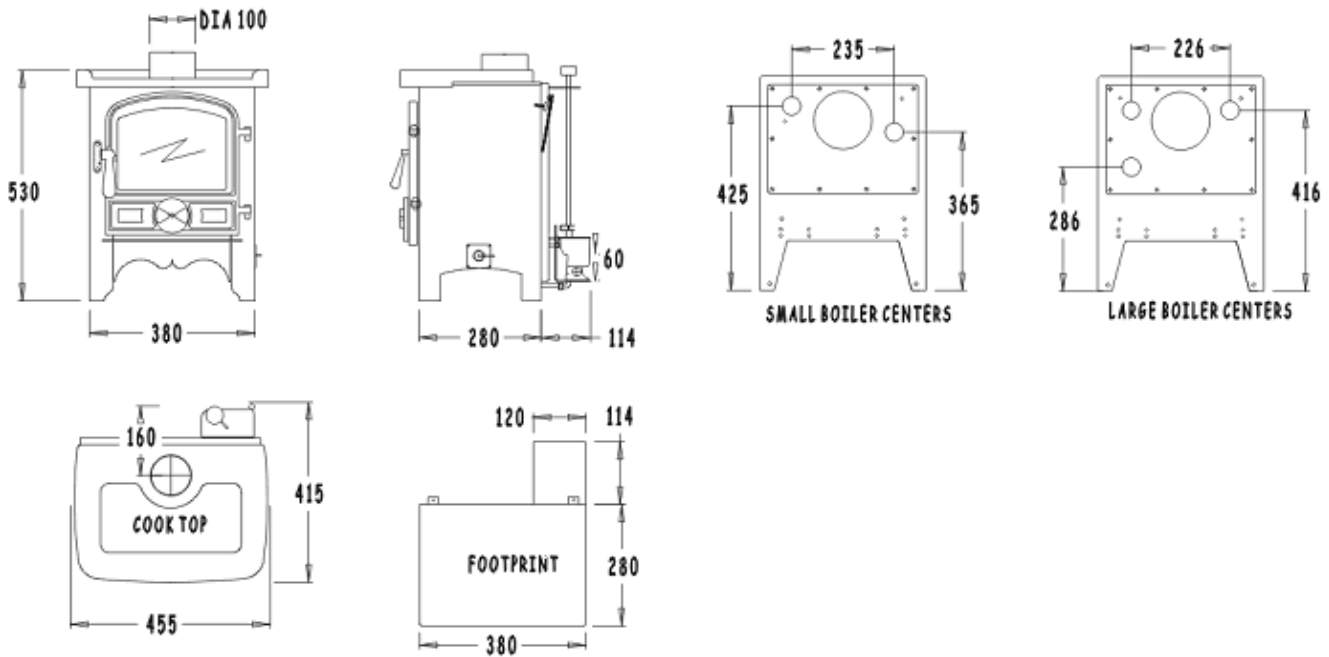

10-2 CORNER STOVE AND CORNER PIE POD DIMENSIONS

Note that the Corner Pie Pod has the same footprint dimensions but the vertical height is 840mm.

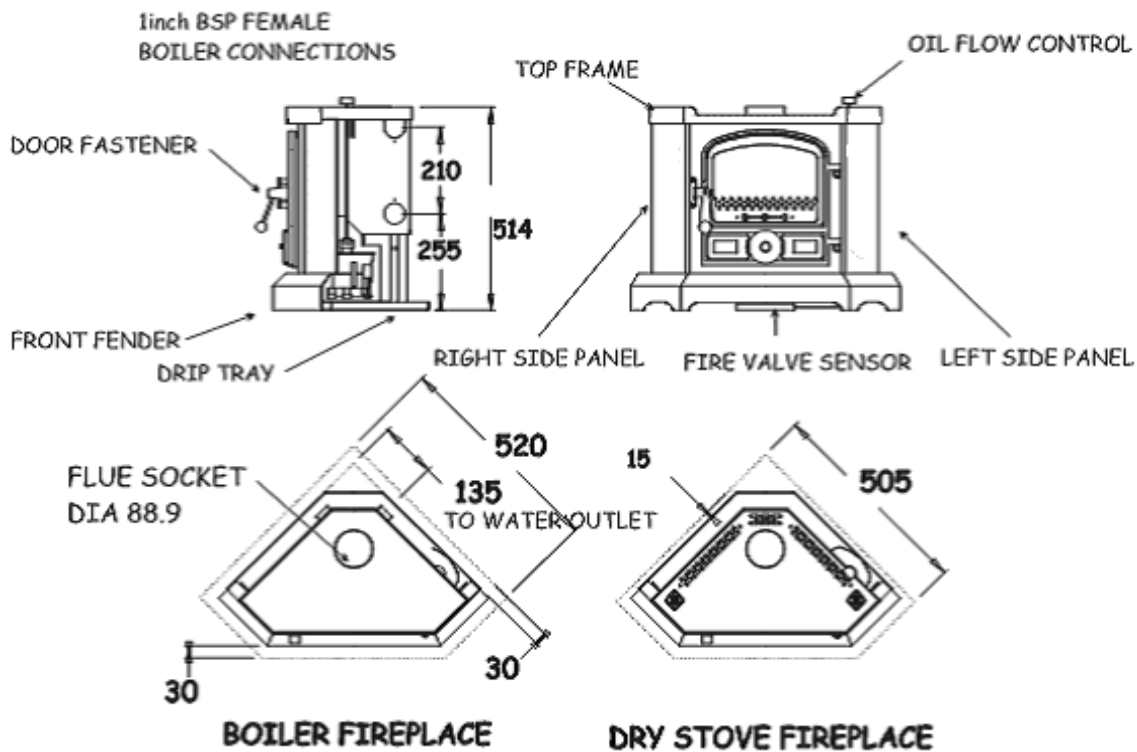

10-3 B2 STOVE DIMENSIONS

Note that the B2 Pie Pod has the same footprint dimensions but the vertical height is 830mm.

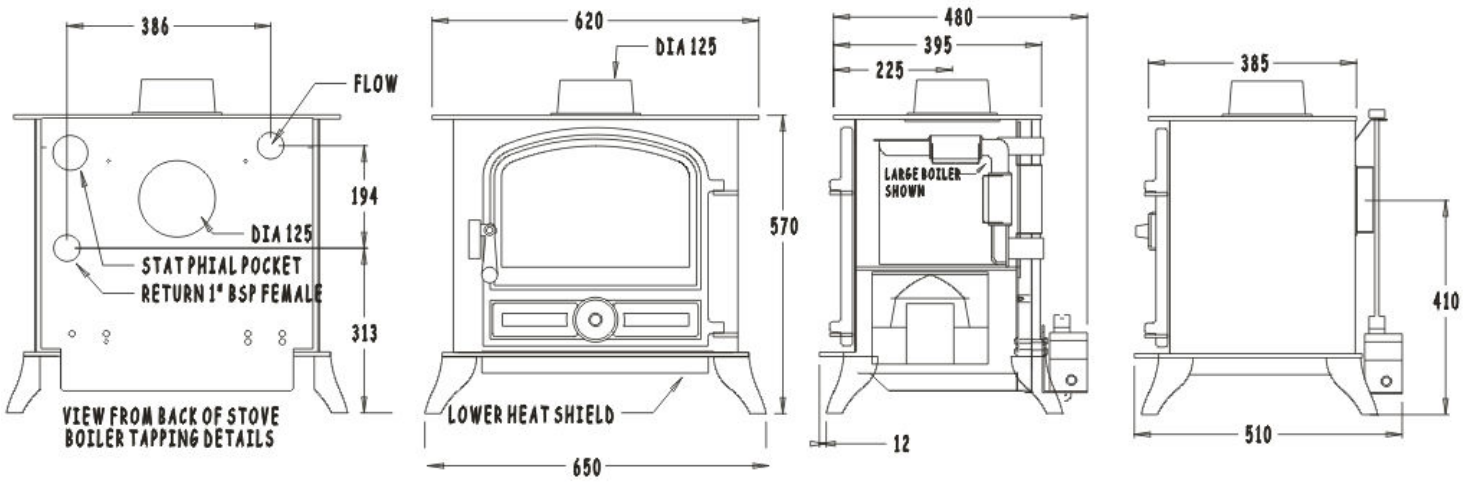

10-4 BACK CABIN COOKER DIMENSIONS

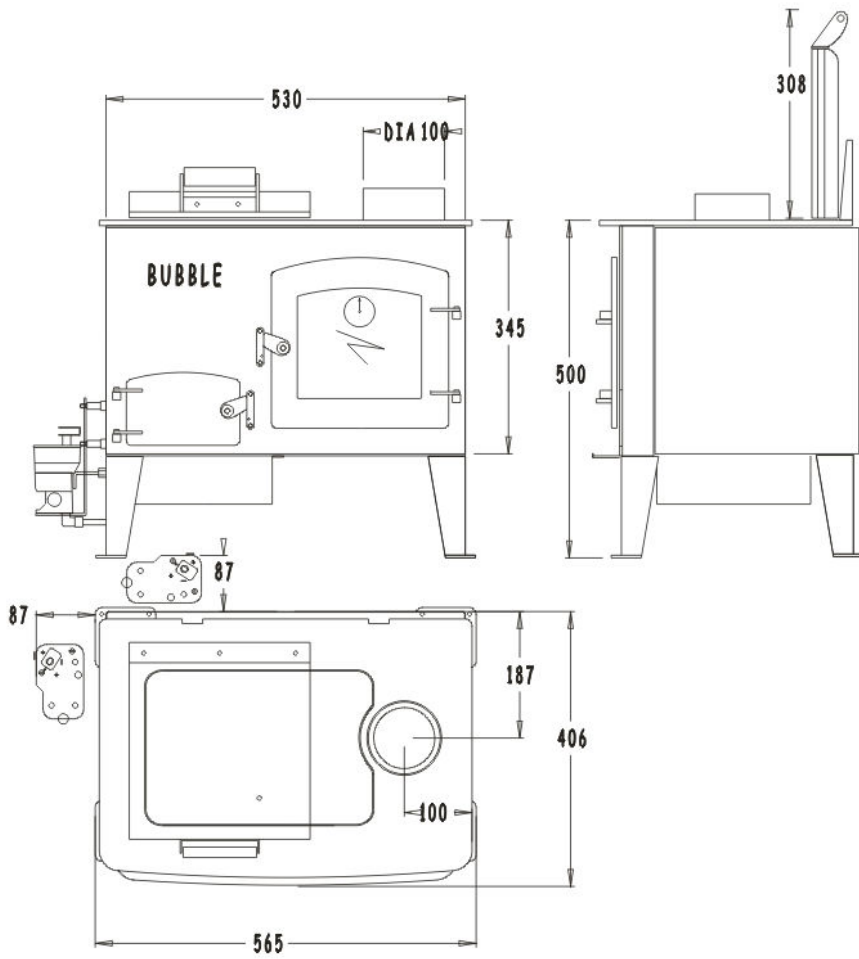

11. OIL CONSUMPTION RATES

		MAX HEAT OUTPUT TO WATER	MAX HEAT OUTPUT TO SPACE	MINIMUM OIL FLOW CC'S PER MIN	MAXIMUM OIL FLOW CC'S PER MINUTE
--	--	--------------------------	--------------------------	-------------------------------	----------------------------------

B1 HALF POD & OVEN DERIVATIVE					
Free Standing	From 1.6kW to 5kW		5kW	4 = (1.6kW)	12 = (5kW)
Free Standing	From 1.6kW to 5kW	2kW	3kW	4 = (1.6kW)	12 = (5kW)
Free Standing	From 1.6kW to 6kW	5kW	2kW	4 = (1.6kW)	13 = (6kW)

CORNER STOVE & OVEN DERIVATIVE					
Free Standing	From 1kW to 4kW		4kW	3 = (1kW)	10 = (4kW)
Free Standing	From 1kW to 4kW	3kW	1kW	3 = (1kW)	10 = (4kW)

BUBBLE 2					
Free Standing	From 1.6kW to 5kW		5kW	4 = (1.6kW)	13 = (5kW)
Free Standing	From 1.6kW to 8kW		8kW	4 = (1.6kW)	16 = (8kW)
Free Standing	From 1.6kW to 8kW	3kW	5kW	4 = (1.6kW)	16 = (8kW)
Free Standing	From 1.6kW to 8kW	9kW	2kW	4 = (1.6kW)	22 = (11kW)

BACK CABIN COOKER					
Free Standing	From 1.6kW to 5kW		3kW	4 = (1.6kW)	7 = (3kW)
Free Standing	From 1.6kW to 5kW	1kW	2kW	4 = (1.6kW)	7 = (3kW)

© HARWORTH HEATING LTD 30.6.98

This publication may not be copied by any means, without written permission from the authors.

These products are subject to continuous development and improvement and it is consequently acknowledged that due to this process there may be some omissions and errors.

This publication is intended only to assist the reader in the use of this product and therefore Harworth Heating Ltd shall not be liable for any loss or damage whatsoever arising from the use of any information, error or omission found in this publication.

The appliances mentioned in this publication can only be installed and serviced by approved personnel.

Approved personnel means that they must HAVE BEEN SUITABLY TRAINED, if there are any

reliability issues reported back to **Harworth Heating** or **Bubble Products**, the installing engineer will be responsible for carrying out any rectification work.

For details of suitable training courses contact: - www.oftec.org

12. NORMATIVE REFERENCES

Boat installation work comes under the control of: -
The Boat Safety Scheme.

This scheme provides statutory requirements and associated EN / BS Standards for most aspects of installation work on boats.

Further information and a copy of the requirements can be obtained from:-

www.boatsafetyScheme.com

Where guidance for oil fired appliances is not readily available from the Boat safety Scheme publication, we then point out a list of standards which pertain to domestic installations and which are generally covered by the latest version of the English Building Regulations Doc J.

When read in conjunction with:-

1. Our installation instructions.
2. The Boat Safety Scheme rules.
3. The other standards detailed, enough information should be provided to allow for a safe installation.

BS 5440	Flues.
BS 6999	Flues
BS 7840	Fuel Hoses.
BS EN1057	Copper Tubes.
BS1344 Part 3 1988 ISO8290 1987	Flues.
BS EN 1443:2003	Chimneys - General requirements.
BS EN1856 part 1 replacing BS 4543	Flues.
BS EN1856 part 2 & BS 715 1993	Flues.
BS 1945: 1971	Stove door
BS EN 10296-1	Steel tubes
BS ISO 10088:2001	
BS EN ISO 9094-2003	
BS EN 10297-1	Steel tubes
BS EN 13384-1	Chimneys
BS EN 10088-1:2005	Stainless steels - Part 1: List of stainless steels

INSTALLATION & GENERAL INSTRUCTIONS



Silent Simplicity just for you!

MARINE OIL STOVES ©

ISSUE 15 @ 22-06-18

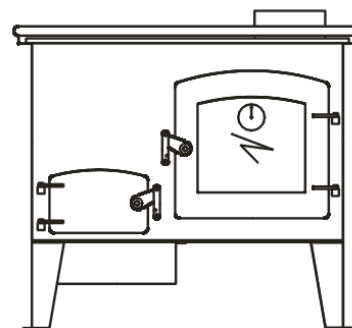
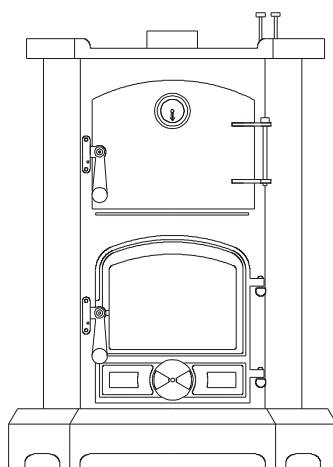
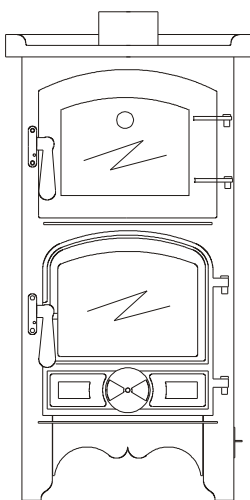
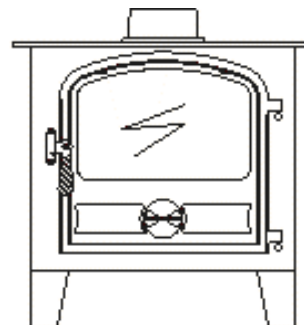
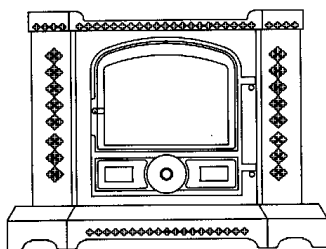
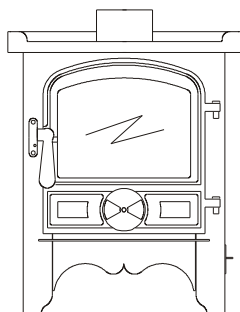

www.harworthheating.co.uk

INDEX

1. BEFORE STARTING THE JOB.	3
FITTING OPTIONS.	3
ABOUT THE APPLIANCES	3
2. SAFETY.	4
FUMES	4
FIRE	4
BURNS	4
CLEARANCES FROM COMBUSTIBLES	4
CLEARANCES FROM COMBUSTIBLES-FLUE PIPES	5
VENTILATION.	5
FLOODED VAPOURIZING BURNER POTS.	5
SECURELY FIX THE APPLIANCE	5
3. CHIMNEY	5
THE HEIGHT.	5
THE DIAMETER.	5
THE TEMPERATURE OF THE GASSES IN IT.	5
THE RESISTANCE OF THE INNER SURFACE OF THE FLUE PIPE OR PIPES.	5
THE TYPE OF TERMINAL.	5
THE PREVAILING ATMOSPHERIC CONDITIONS.	5
THE CHIMNEY RULES.	6
4. FUEL SUPPLY.	6
WAXING	6
AIR LOCKS	6
TRIM	6
TANK	6
OIL LINE	6
WATER CONTAMINATION	6
REMOTE SENSING FIREVALVES	7
ISOLATION VALVES.	7
SLEEVING.	7
OVERBOIL OR OVERHEAT PROTECTION OF THE APPLIANCE.	7
4A LIGHTING & COMMISSIONING	7
1. LIGHTING B1 HALF POD, B1 PIE POD AND B2	7
COMMISSIONING THE HIGH & LOW FIRE, CHRYSTAL SERIES	8
4B LIGHTING & COMMISSIONING THE BURNER SOCOMEF SERIES	9
1. LIGHTING CORNER STOVE, CORNER POD AND BACK CABIN COOKER.	9
COMMISSIONING THE HIGH AND LOW FIRE SOCOMEF BURNERS.	10
5. FIREPLACE.	10
6. DISTANCES FROM COMBUSTIBLES (APPLIANCES)	11
7. DISTANCES FROM NON COMBUSTIBLES (APPLIANCES)	11
8. DISTANCES FROM COMBUSTIBLES (FLUE PIPES)	11
9. ILLUSTRATIONS	12
FIG 1. STOVE DISTANCE FROM COMBUSTIBLES	12
FIG 2 BUBBLE MK1 FABRICATED DECK FLANGE LAYOUT	12
FIG 3 TYPICAL OIL FEED LAYOUT	13
FIG 4 TYPICAL PUMBING LAYOUTS	13
10. STOVE DIMENSIONS	14
10-1 BB1 HALF POD AND PIE POD DIMENSIONS	14
10-2 CORNER STOVE AND CORNER PIE POD DIMENSIONS	15
10-3 B2 STOVE DIMENSIONS	15
10-4 BACK CABIN COOKER DIMENSIONS	16
12. NORMATIVE REFERENCES	18

If you have any difficulties please phone our technical help line on-:

01302 742520 fax 01302 750573

e-mail contact@bubbleproducts.co.uk

<http://www.bubbleproducts.co.uk>

1. BEFORE STARTING THE JOB.

THE FOLLOWING NOTES PROVIDE INFORMATION FOR INSTALLATION OF THE FOLLOWING APPLIANCES.

Boat Bubble No 1 AND HALF POD, Dry Small and Large Boiler Appliances

Boat Bubble No 2 Dry Small and Large Boiler Appliances

Marine Corner Bubble Wet and Dry appliances

Bubble No 1 Cooking Stove plus boiler options.

Corner Cooking Stove plus boiler options.

Back Cabin Oil Fired Cooker.

FITTING OPTIONS.

There are normally two different situations that the installer may be faced with:-

1. A new build installation.

An established boat installation, (which has not had oil stove fitted).

2. A replacement installation, where there has been a solid fuel stove fitted previously.

Each of the situations will present differing problems which will be:-

- Where to locate the stove.
- How to deal with fireplace design.
- Where to locate the oil tank.
- How to get an oil supply to the stove.
- How to fit the chimney.
- How to connect water to the stove.
- How to disconnect and remove the stove, easily.

The new build situation should be the easiest.

The established boat situation will require careful attention to the sighting of the stove in relation to flue positions and existing fittings positions.

In replacement situations it may well be necessary to blank off the existing through roof flue position and cut a fresh one to suit the new location and comply with our instructions on flue design.

ABOUT THE APPLIANCES

Generally described as a space heater or space heater and cooker, which burns diesel oil in a controlled

manner utilizing a chimney to discharge the products of combustion.

The appliance generates heat from burning oil mixed with air in a vaporizing pot located in the bottom of the stove.

Once the appliance has been ignited, oil goes into the pot at a steady and controlled rate via a gravity feed which is metered by the OIL CONTROL VALVE; the oil flow can be controlled from minimum to maximum or any setting in between determined by the set position of the oil flow control knob.

Air is sucked into the pot by the natural action of the negative pressure in the chimney.

To allow the chimney to work correctly it is essential that you have adequate, unrestricted ventilation into the area where the stove is situated.

The amount of oil that can be successfully burned is directly proportional to the amount of air that the chimney can draw into the pot and so to achieve adequate combustion a balanced and appropriate flow of both oil and air is required.

The stove will provide space or combined space and water heating and in some cases cooking as well.

Where cooking and water heating are combined one feature will inevitably effect the other.

There are different versions of each appliance within the total range.

Some of the appliances are supplied as Dry, Small Boiler and Large Boiler versions namely B1 Half Pod, B1 Oven and B2.

Some of the appliances are supplied just as Dry and Large Boiler versions namely Corner Stove and Corner Oven Stove.

The Back Cabin Cooker can be supplied with or without a small boiler for domestic hot water heating only.(1kw)

All of the boilers are high water content and suitable for pumped or gravity systems and pressurised or open vented systems ASSUMING THAT THEY ARE INSTALLED BY SUITABLY QUALIFIED PERSONS.

All the appliances are fitted with a descaling device which should be rotated on a two weekly cycle to descale the oil inlet pipe.

Where applicable, appliances must not be operated with the glass front door opened or cracked, or without the lighting port plug fitted.

Where applicable, the door glass may require light cleaning occasionally depending upon the continuous running time of the stove.

Appliances must be securely bolted down to resist impact or collision and must be level in both directions.

All the appliances are supplied with clamp down brackets except the Back Cabin Cooker which must be fastened down through the foot plates.

The top of the appliances can be used for warming and cooking.

The oven appliances have a comprehensive range of cooking facilities with both oven and hot plate cooking available.

Some appliances can also be supplied with a coal kit, which just like a solid fuel stove, coal effect will only be available when the stove is running at maximum or near maximum performance.

Suitable deck flanges, flue systems and anti-downdraft cowls must be used.

CONTROLS

The output of the stove is regulated by the amount of oil allowed to go into it and this function is controlled by the -:

OIL CONTROL VALVE (O.C.V.), Turning the knob anti clockwise controls the oil flow.

2. SAFETY.

Take care to make sure that all safety and ventilation issues are adequately addressed.

FUMES

Always fit a suitable Smoke and Carbon Monoxide alarm within 1.5meters of the appliance.

Make sure that the function is checked on regular basis. (weekly)

Make sure that the alarm can be heard in the sleeping quarters.

Here are the main causes of fume or smoke to leak from the stove.

- The chimney is blocked.
- There are too many bends in the chimney.
- The above deck chimney extension is not high enough.
- The boat is moored in a position near to high buildings or trees and downdraughting is occurring.
- The chimney or parts of it are not airtight.

- There are unusually strong cross winds.

If down draughting occurs turn the appliance off until the winds subside and do not attempt to re-ignite the appliance until it has completely cooled down.

When it has cooled down, before attempting to ignite the appliance remove the catalyser and examine the base of the pot to make sure that there is no oil left in the pot, if there are signs of oil in the pot do not attempt to ignite the appliance until it has been completely dried out.

FIRE

Fire can be caused by a variety of potential danger points and because of the space limitation on boats; this risk is ever present and must be adequately assessed.

The main danger is the effects of heat from the stove on combustible materials and boat occupants.

Make sure that all combustibles are adequately protected from the effects of heat radiation.

Appliances must stand on a fireproof base of minimum thickness 30mm or a purpose made stand.

Floors in front of the stove must have suitable fire protection.

Built in stove heat shields should not be removed under any circumstances.

BURNS

During normal, day-to-day use, many parts of the stove, pipe work, and chimney will become too hot to touch.

Hot surfaces must be adequately protected to prevent anyone falling on to, or touching them.

Suitable fireguards for the appliance and chimney must be fitted.

Fireguards must comply with BS6539.

Always use heatproof gloves when working on or near to a hot stove.

CLEARANCES FROM COMBUSTIBLES

The appliances must be fitted in line with the distances specified in the tables.

All hearths and fireplaces must be made from non-combustible materials and adequately designed for the job.

CLEARANCES FROM COMBUSTIBLES-FLUE PIPES

Flue pipes must be fitted in line with the distances specified in the table and must be suitable for the individual application.

Any combustible materials within the specified distances from the appliances must be protected by a suitable heat shield.

Protection can be gained by the use of -:

- Sheet metal heat shields and spacers.
- Heat resistant boards such as TAC board.
Combustible materials can be-:
- Wooden furniture.
- Curtains.
- Wooden panels or frames adjacent to the flue pipe or where it passes through the deck of the boat.
- Carpet or flooring close to the stove.
- Items near to the stove, which could fall onto it and ignite, should the boat suffer a slight impact or collision.

VENTILATION.

Ventilation plays a vital role in the fitting and sighting of any stove.

The provision of ventilation for these appliances is adequately covered by the requirements of the boat safety scheme.

25cm sq. minimum permanent ventilation, directly to outside air, must be provided.

FLOODED VAPOURIZING BURNER POTS.

When attempting to light any of the appliances, make sure that the pot is not flooded with oil by looking into the base of the burner.

If it is flooded remove the excess oil.

Never try to relight a hot stove; wait until it has cooled down.

Hot oil vapour is explosive.

Never try to light a flooded pot.

SECURELY FIX THE APPLIANCE

The stove must be securely fastened down so that it can resist impact or collision and it must be level in both directions.

Level the stove in both directions when the vessel is midway between its maximum and minimum trim conditions.

Bubble appliances must not be fitted if the maximum angle of trim exceeds 0.75 deg forward to aft or port to starboard.

Only suitably qualified persons can install unvented plumbing systems.

A suitable and serviceable fire extinguisher should always be readily accessible.

3. CHIMNEY

This is the one of the most interesting problems the installer has to deal with and as the chimney affects most aspects of running the stove, we take time here to list the following information for your consideration.

The power, (*suck or vacuum the chimney can develop*) depends upon the following-:

THE HEIGHT.

THE DIAMETER.

THE TEMPERATURE OF THE GASSES IN IT.

THE RESISTANCE OF THE INNER SURFACE OF THE FLUE PIPE OR PIPES.

THE TYPE OF TERMINAL.

THE PREVAILING ATMOSPHERIC CONDITIONS.

It is obvious that on a boat all the above elements are in short supply.

Normally, we have low flues which are small in diameter and generally not very well insulated, coupled with all these problems we have another one, which is that the boat moves across constantly changing surroundings, through locks, into headwinds and crosswinds, all creating major opportunity for down draughting to occur.

Any bend in any part of the chimney or roughness on the internal chimney wall will slow down the velocity of rising gases and reduce the effectiveness of the chimney.

Any slight reduction in the flue gas temperature will reduce the chimney vacuum or pull, hence when the stove is slowed down for all night burning, as the flue gas cools down the chimney vacuum reduces and as the chimney vacuum drops, the stove may well start to burn sooty. This problem is highlighted even more during very cold weather when the chimney can cool down even faster. In these situations careful attention to servicing and low fire setting is essential.

THE CHIMNEY RULES.

1. Always use a top outlet for flue pipe take off.
2. Always try to get the stove as low as possible in the boat, this will allow installation of maximum length flue pipe.
3. Clean or have the chimney cleaned regularly. (Frequency depends upon type of fuel and length of time used).

4. FUEL SUPPLY.

There are several problems relating to diesel fuel supply, which need be adequately addressed.

WAXING

Cold weather waxing or thickening alters the flow characteristics of diesel.

An adequate fuel feed supply can turn into an inadequate one when the temperature starts to fall.

The worst scenario is fuel feed pipe 50-60 feet long in 8mm dia pipe.

The best-case scenario is a fuel pipe 4 feet long in 10mm dia with insulated lagging.

AIR LOCKS

Air lock in oil feed pipe work must be avoided.

The pipe work must slope down to the appliance and be clipped level at 500mm intervals to prevent sagging.

Any rises in the pipe work will cause air locks on commissioning and after future oil run out situations, if it is not possible to run the pipe work in a steady slope then where changes occur a vertical venting leg should be fitted.

TRIM

Bubble appliances must not be fitted if the maximum angle of trim exceeds 0.75 deg forward to aft or port to starboard.

Level the stove in both directions when the vessel is midway between its maximum and minimum trim conditions.

A minimum pressure head of 254mm (10") is required.

This head is measured from the base of the oil tank to the top of the oil control valve. In some cases this head can be affected by the ballast or trim of the boat.

Take great care to try out all the different ballast and trim possibilities to make sure that adequate oil feed is always available at the outlet end of the fuel pipe before it enters the oil control valve at the stove.

TANK

If the stove is fitted at the bow of the boat, a bow tank is recommended.

The tank should comply with the requirements of the boat safety scheme and have:-

- A conveniently sized filler
- A means of venting.
- A conveniently located, easily visible, contents gauge.
- An isolation valve
- An easily replaceable cartridge filter.
- A suitable and substantial water trap

Do not use glass filter bowls, they are not acceptable under the boat safety scheme.

Make sure that your fuel supplier supplies you with appropriate fuel for wintertime running.

OIL LINE

The oil feed line starts after the fuel filter and proceeds to the point of entry, which is where the oil line goes into the cab or saloon of the boat.

The diameter of the oil line is dependent upon the length of run. See 3-2 on waxing and make sure that you have suitably sized compression fittings available.

At this point it is necessary to fit a 60 DEG C, remote sensing fire valve, designed to shut off the oil supply, should a fire occur near to the stove.

If the bubble stove is fitted up to the first bulkhead it will be necessary to fit the isolation valve outside the cabin or saloon of the boat. 5. Make sure that you have purged the oil feed line of all air and there is a steady and constant flow of oil available at the inlet to the oil valve. Make sure that all or any oil isolation devices are turned to the on position. Remember that the oil valve needs a min head of 300mm for gravity feed. When feeding from rear tanks with appliances fitted forward always be aware of the forward - aft trim of the vessel.

Do not use syphonic oil feeds to Bubble Appliances, oil should be fed by gravity or pumped via an appropriate pressure pump = head pressure less than 99mbar.

WATER CONTAMINATION

Because of the high risk of fuel contamination with water, we strongly recommend the fitting of a **high volume water trap**, in the oil supply line.

REMOTE SENSING FIREVALVES

There are two situations where a remote sensing firevalve should be fitted.

1. For fire protection fit a 60 deg C valve.
2. For over boil protection fit an additional 90 deg C valve.

For fire protection a remote sensing fire valve should be fitted as detailed in fig 3.

Run the capillary tube with the oil line up to the stove and carefully fit the sensing phial as follows

B1 Half Pod, B1 Oven and B2 at a low level fitted on two 15mm pipe clips.

Corner Stove and Corner Oven Stove on 15mm pipe clips in front of the drip tray on the fireplace hearth, directly in front of the combustion air restrictor.

Before it is fitted try the fender on the stove to make sure that the fender does not foul the sensing phial.

The sensing phial may be visible through the bottom of the fender, to mask it, paint it with matt black paint available from our sales desk.

When fitting the fire valve make sure that where the capillary and oil line go through the bulkhead in separate sleeved tubes, so that the capillary can be withdrawn separately should it ever need replacing.

For fitting of long oil feed lines which pass through bulkheads and various other parts of the boat it may well be necessary to fit more than one fire valve, especially where the oil line passes through an area where a fire could occur i.e. kitchen area etc.

ISOLATION VALVES.

Two isolation valves are required, one fitted directly into or close to the oil control valve to allow you or the service man to turn the oil off should the need arise, and one fitted directly into the oil tank before the fuel filter.

Always turn off the oil isolation valve serving the appliance before leaving the vessel unattended.

SLEEVING.

Where the oil line goes through the boat superstructure a suitable bulkhead fitting must be used.

OVERBOIL OR OVERHEAT PROTECTION OF THE APPLIANCE.

Where appliances are not fitted with an automatic thermostat an additional 90 DEG C, remote sensing

fire valve must be fitted directly in front of the oil control valve and the sensor from this valve has to be attached to the water jacket or the hot outlet pipe from the boiler.

The valve is calibrated to shut the oil supply down should the water temperature exceed 90 Deg C.

There is a re set button on the remote sensing fire valve which needs to be pressed in to re set the valve after it has tripped off.

4A LIGHTING & COMMISSIONING

A relevant oil control valve catalogue is supplied with each appliance and details of high and low fire adjusting screws are illustrated.

On the Toby valve the low fire screw is clearly visible as per TOBY MANUAL FIG 2

Before trying to light the burner in cold weather it is advisable to pre heat the flue pipe before lighting.

There are two different types of burner fitted to Bubble appliances.

The FB style burner fitted to the **B1 Half Pod, B1 Pie Pod and B2.**

The Socomef burner fitted to the **Corner Stove, Corner Oven Stove** and the **Back Cabin Cooker see sec 4B for lighting Socomef burners.**

1. LIGHTING B1 HALF POD, B1 PIE POD AND B2

When attempting to light the stove these are the rules, which must be followed.

1. Always make sure that the pot is **not** flooded with oil by looking down into the base of the pot.
2. Never try to light the stove if it is flooded with oil.
3. Always check that oil has not leaked from the appliance.
4. Do not light the stove and leave it unattended until it is settled down and stabilized into constant blue flame combustion on low fire. (This could take 10 to 20 minutes.)

On first light up it is advisable to warm the flue pipe up to try and create chimney draft.

Two Ways to Light the Stove

1. Through the lighting port B1 and B2 appliances only,
or
2. Directly into the base of the pot by removing the catalyser.

Lighting into the base of the Pot

On the first light up you may find this option better, as it is possible to see the oil trickle in to the pot more easily.

Use a heatproof glove when putting the catalysers back into the pot and it is important to replace them quickly whilst the flame is small.

Make sure that the oil is turned off.

Open the front door.

Remove the optional coal kit if fitted.

Remove the catalyser.

Turn the oil on and allow a small pool of oil to flow into the pot about the size of a small biscuit, **then turn the oil off.**

Note that on first light up it may take a few minutes for the oil to reach the pot as it has to fill the pipework before reaching the pot, take care not to allow excess oil to flow into the pot.

Light a small piece of firelighter and drop it into the oil, allow a few seconds for it to get going and then replace the catalyser and coal kit if fitted, and close the door.

Wait for approx. 1 minute until the pool of oil is alight and then **turn the oil on** to minimum setting no 1.

Watch the appliance for a few minutes and you will see the flame establish and settle down into blue flame combustion.

Allow the burner to run for a further 10 minutes before turning the appliance up to the higher settings.

If at any time during the ignition process large amounts of flame can be seen, turn the oil off immediately and wait until the flames die down before putting the oil on again at minimum setting.

Manual Lighting through the Lighting Port B1 and B2 appliances.

Check that the isolation valve is turned on.

Open the front door.

Remove the front apron on B1 Half Pod and B1 pie Pod.

Remove the lighting port plug by pulling it out of its tubular socket.

Turn the oil on to the first position via the flow control knob and allow a small pool of oil to flow into the pot about the size of a small biscuit.

Turn the oil off.

Cut a small piece of firelighter and stab it onto the spike.

Light it and push it into the lighting port tube, let the firelighter drop off the spike into the bottom of the pot.

Replace the lighting port plug back into the tube.

Close the front door.

Turn the fuel flow on again at the lowest setting

Watch the appliance for a few minutes until it settles down into blue flame combustion.

Allow the burner to run for a further 10 minutes before turning the appliance up to the higher settings.

If at any time during the ignition process large amounts of flame can be seen, turn the oil off immediately and wait until they die down before putting the oil on again.

Note there may be the occasional growl or audible vibration whilst the burner settles down into blue flame combustion.

COMMISSIONING THE HIGH & LOW FIRE, CHRYSTAL SERIES

Used in B1 Half Pod, B1 Pie Pod and B2

When the burner has established good blue flame combustion turn it up to half output. (Setting 3 on the fuel flow control knob) and let it stabilize.

Allow at least half an hour for the chimney to warm up thoroughly before making any adjustments to the high or low fire screws.

Turn the stove down onto minimum firing rate and let it stabilize.

After stabilization there should be a dull red glow in the lower catalyser with wispy blue flames flicking into and just over it.

If the flame falls into a dirty rolling yellow flame and the catalyser is not dull red then the low fire will need to be increased until it can support the required blue flame combustion.

To increase the low fire oil flow, screw the adjusting screw out by quarter turn increments.

When you are happy with the low fire, set the high fire.

Turn the oil flow knob up to setting 4, let the flame stabilize, and look at it, if it is stable and blue, turn it up slowly using the control knob, letting it stabilize after each movement, if the flame starts to go yellow with long flame combustion, it is running fuel rich and

the high fire screw needs adjusting to reduce the flow of oil. (Screw the adjuster screw in to reduce the high fire oil flow.)

Before adjusting the high fire screw, turn the flame down and let it stabilize in blue flame combustion, adjust the high fire screw by half a turn in and try turning the fuel flow up, if it is still fuel rich repeat the process until the high fire flame is running blue with just flicks of yellow in the tips.

To see a bubble stove running correctly see the following link

<https://www.youtube.com/watch?v=UqdQLFp3HkQ>

4B LIGHTING & COMMISSIONING THE BURNER SOCOMEF SERIES

1. LIGHTING CORNER STOVE, CORNER POD AND BACK CABIN COOKER.

When attempting to light the stove these are the rules, which must be followed.

1. Always make sure that the pot is not flooded with oil by looking down into the base of the pot.
2. Never try to light the stove if it is flooded with oil.
3. Always check that oil has not leaked from the appliance.
4. Do not light the stove and leave it unattended until it is settled down and stabilized into constant blue flame combustion on low fire. (This could take 10 to 20 minutes.)
5. Make sure that you have purged the oil feed line of all air and there is a steady and constant flow of oil available at the inlet to the oil valve. Make sure that all or any oil isolation devices are turned to the on position. Remember that the oil valve needs a min head of 300mm for gravity feed. When feeding from rear tanks with appliances fitted forward always be aware of the forward - aft trim of the vessel.
6. Do not use syphonic oil feeds to Bubble Appliances, oil should be fed by gravity or pumped via an appropriate pressure pump = head pressure less than 99mbar.

On first light up it is advisable to warm the flue pipe up to try and create chimney draft.

Lighting the Stove

Lighting the stove takes a little time and patience; the following procedure should be adopted.

In the case of the Corner appliances, open the front door and in the case of the Back Cabin Cooker remove the hot plate and top baffle to gain access to the

burner, note that the back cabin cooker has a lighting port fitted behind the lower ash pit door.

Remove the coal kit if it has been supplied with the stove.

Lift the inner mesh catalyser from the burner.



Look into the bottom of the pot and turn the oil on at full rate, allow oil to flow into the bottom of the pot to form a pool about the size of a small digestive biscuit and then turn the oil off.

Note that on first light up it may take a few minutes for the oil to reach the pot as it has to fill the pipework before reaching the pot.

Do not allow any depth of oil to build up.

Light a small piece of firelighter (about the size of a pineapple chunk) and place it into the centre of the oil pool.

Replace the mesh catalyser and the coal kit, if fitted and then leave the door slightly open whilst the firelighter gets the oil going.

After 30 to 40 seconds, you will notice the flame start to establish itself and spread around the bottom of the pot.

When this occurs, close the door or replace the baffle and top plate and then turn the oil on to its minimum setting.

After two or three minutes the flame should slowly change from yellow into blue flame combustion and settle down to a steady burn.

Note there may be the occasional growl or audible vibration whilst the burner settles down into blue flame combustion.

Allow the burner 10 - 15 minutes to stabilise and the increase the flow of oil as required, moving by one increment of the dial only.

Do not leave the appliance unattended during the lighting and stabilising procedure.

COMMISSIONING THE HIGH AND LOW FIRE SOCOMEF BURNERS.

Corner Stove, Corner Pod and Back Cabin Cooker.

Note that Back cabin Cookers are pre commissioned at the factory and do not need adjusting.

A relevant oil control valve catalogue is supplied with each appliance and details of high and low fire adjusting screws are illustrated.

On the Toby valve the low fire screw is clearly visible as per TOBY MANUAL FIG 2

When the burner has established good blue flame combustion turn it up to half output. (Setting 3 on the fuel flow control knob) and let it stabilize for a minute. Allow at least half an hour for the chimney to warm up thoroughly before making any adjustments to the high or low fire screws.

Turn the stove down onto minimum firing rate and again let it stabilize.

After stabilization there should be a dull red glow in the catalyser with wispy blue flames flickering just over the top of it, approximately level with the top of the pot.

If the flame falls into a dirty rolling yellow flame and the catalyser is not dull red then the low fire will need to be increased until the burner can support the required blue flame combustion.

When you are happy with the low fire, set the high fire.

Turn the oil flow knob up to setting 4, let the flame stabilize, and look at it, if it is stable and blue, turn it up slowly using the control knob, letting it stabilize after each movement, if the flame starts to go yellow with long flame combustion, it is running fuel rich and the high fire screw needs adjusting to reduce the flow of oil. (Screw the adjuster screw in to reduce the high fire oil flow.)

Before adjusting the high fire screw, turn the flame down and let it stabilize in blue flame combustion, adjust the high fire screw by half a turn in and try turning the fuel flow up, if it is still fuel rich repeat the process until the high fire flame is running blue with flicks of yellow in the tips.

On the Socomef pot, the high fire flame will be set approx. 40mm above the top of the pot.

NOTE THAT THIS PROCEDURE WILL NOT BE POSSIBLE IF THE CHIMNEY RULES HAVE NOT BEEN ADHERED TO.

THE HIGH FIRE SETTING WILL HAVE TO BE ADJUSTED IN LINE WITH THE AVAILABLE GENERATED CHIMNEY VACUUM IE

THE FLUE PIPE MUST BE A MINIMUM OF 1.8 METERS HIGH FOR LOW FIRE AND 2.1 METERS FOR HIGH FIRE.

INSTALLING ENGINEERS SHOULD NOT LEAVE THE APPLIANCE UNDER THE CONTROL OF THE CUSTOMER UNLESS THE APPLIANCE HAS BEEN CORRECTLY COMMISSIONED.

TO SEE HOW THE BURNER SHOULD OPERATE COMMISSIONING AND INSTALLING ENGINEERS SHOULD VISIT

<https://www.youtube.com/watch?v=UqdQLFp3HkQ>

This video shows a stove running from low to high fire and back to low fire. Note that this video is filmed on a normal house chimney and so it may not be possible to get exactly the same conditions on a typical boat flue as the fuel air ratio will not be exactly the same, hence the need for fine tuning the oil flow to the chimney air flow capability.

5. FIREPLACE.

Unless one is built into the appliance, always fit appliances on a suitable drip tray.

The possibility of oil drops leaking from the stove must be considered; a suitable oil drip tray must be fitted and designed in such a way, as it will contain any oil leaks or drips.

Normally the tray will cover the footprint of the stove, the oil valve and isolation device.

It will be oil tight and have a vertical up stand of at least 30mm. This should give a minimum containment volume of 2 litres.

It will be securely fastened down to the vessel and the appliance must be securely fastened down to the oil drip tray.

Make sure that drip trays are tested to ensure that they do not leak when filled with oil.

The hearth must be:-

FLAT - SECURE - FIREPROOF AND LEVEL IN BOTH DIRECTIONS.

Use materials, which are easy to keep clean and fireproof such as tiles, asbestolux or vermiculite boarding with a suitable weight resistant liner.

The vertical walls of the fireplace must also be made from fireproof materials.

Use fireproof, rockwool infill behind the fireplace panels to protect any combustible insulation materials

such as spray foam.

6. DISTANCES FROM COMBUSTIBLES (APPLIANCES)

Stove Type	ABOVE	SIDES.	BACK	FRONT	HEARTH Non Combustible Material
B1 HALF POD and OVEN VERSION	500	300	150 FROM HEAT SHIELD	300 to allow door opening.	30MM THICK x 100 projection at the front and sides
BOAT B2	600	300	150 FROM HEAT SHIELD	300 to allow door opening.	30MM THICK x 100 projection at the front and sides
CORNER and OVEN VERSION	500	75	100 FROM HEAT SHIELD	300 to allow door opening.	30MM THICK x 100 projection at the front.
BACK CABIN COOKER	500	150	100 FROM HEAT SHIELD	300 to allow door opening.	25MM THICK x 150 projection at sides

7. DISTANCES FROM NON COMBUSTIBLES (APPLIANCES)

Stove Type	ABOVE	SIDES.	BACK	FRONT	HEARTH Non Combustible Material
B1 HALF POD and OVEN VERSION	300	150	150 FROM HEAT SHIELD	300 to allow door opening.	30MM THICK x 100 projection at the front and sides.
BOAT B2	300	150	150 FROM HEAT SHIELD	300 to allow door opening.	30MM THICK x 100 projection at the front and sides.
CORNER and OVEN VERSION	200	150	25 FROM HEAT SHIELD	300 to allow door opening.	30MM THICK x 100 projection at the front and sides.
BACK CABIN COOKER	500	75	50 FROM HEAT SHIELD	300 to allow door opening.	25MM THICK x 75 projection at sides

Note that the back cabin cooker can have the oil control valve fitted to the rear or the left hand side in each case the positioning of the valve will affect the fireplace and spacing considerations, see sizes of cooker to establish requirements.

8. DISTANCES FROM COMBUSTIBLES (FLUE PIPES)

For all appliances-:

1. Single skin flue pipes. Horizontal Distance = 50mm **when fitted within the deck flange** at the top of the chimney system, protected by the fire stop spacer.
2. Single skin flue pipes. Horizontal Distance = 150mm **when exposed in the saloon or living space.**
3. Twin Wall Insulated flue pipes. Horizontal Distance = 30 mm for insulated flue pipe systems.

9. ILLUSTRATIONS

FIG 1. STOVE DISTANCE FROM COMBUSTIBLES

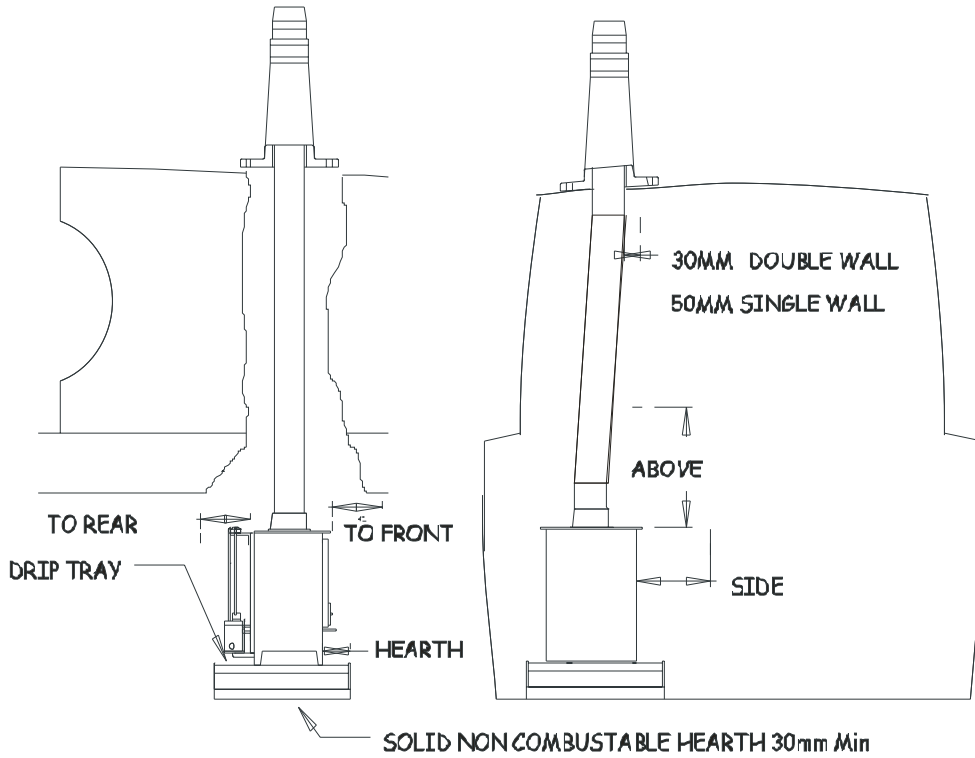

FIG 2 BUBBLE MK1 FABRICATED DECK FLANGE LAYOUT

Note that there is mk3 system which is now available and detailed on our web site.

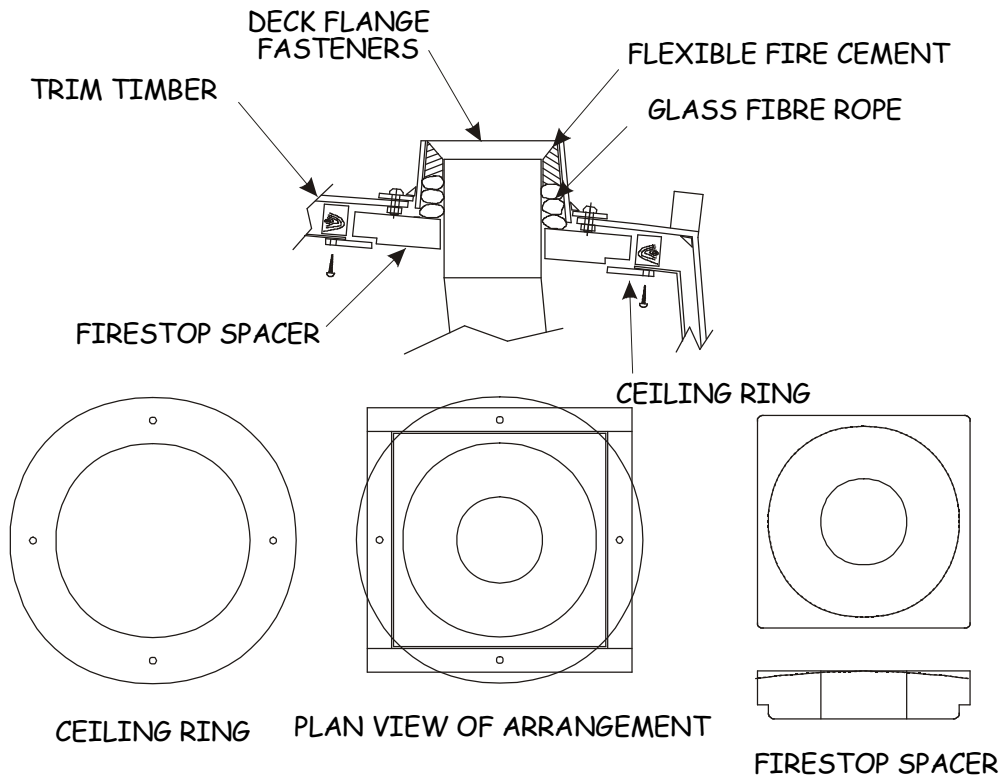
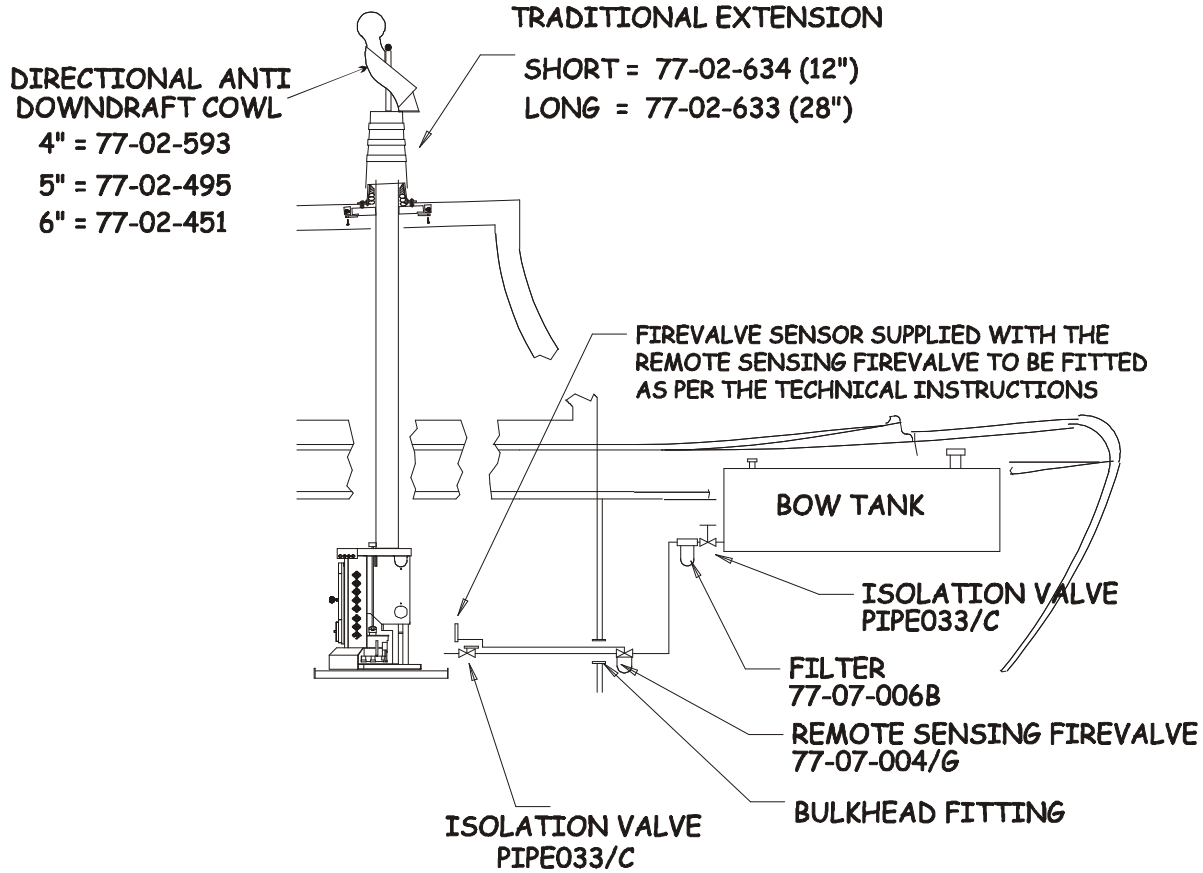

FIG 3 TYPICAL OIL FEED LAYOUT



COPYRIGHT HARWORTH HEATING LTD 080800

FIG 4 TYPICAL PUMING LAYOUTS

Drq 1

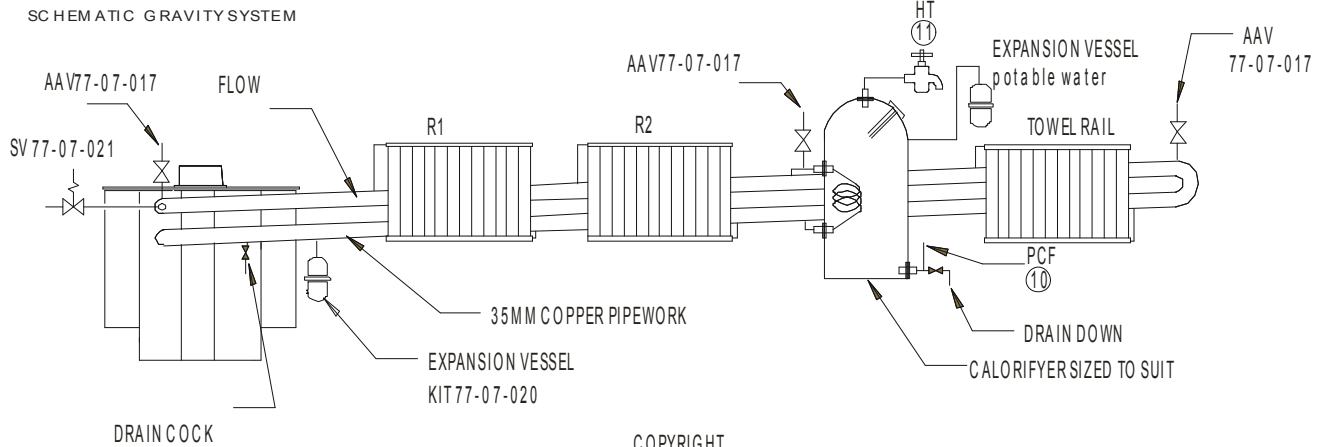

COPYRIGHT BUBBLE PRODUCTS 2013

Drg 2

SCHEMATIC PUMPED SYSTEM ISS 2 OF 28-10-17

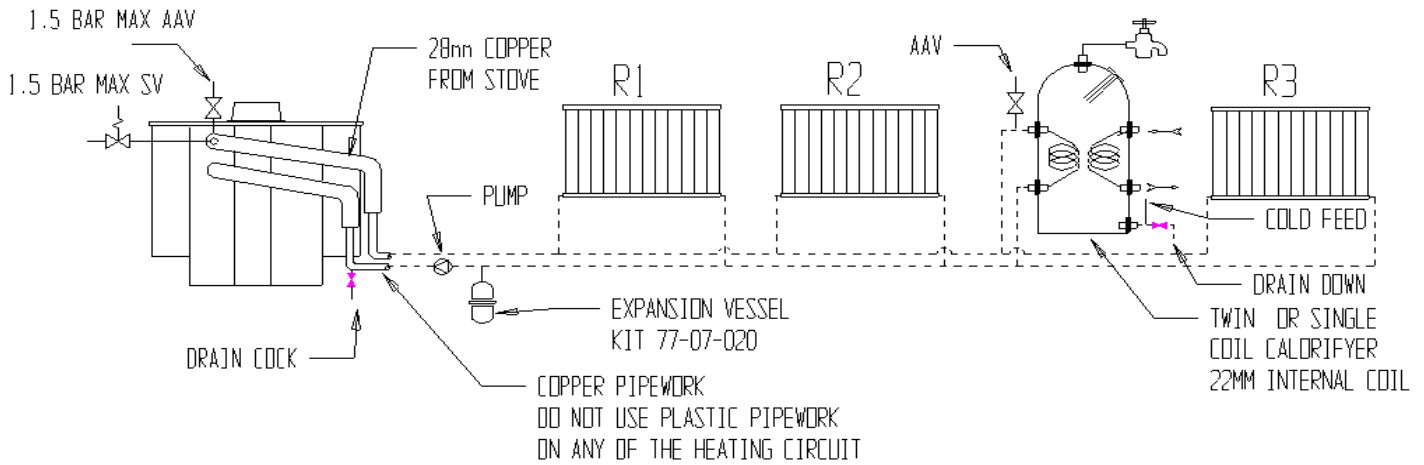

Drg 3

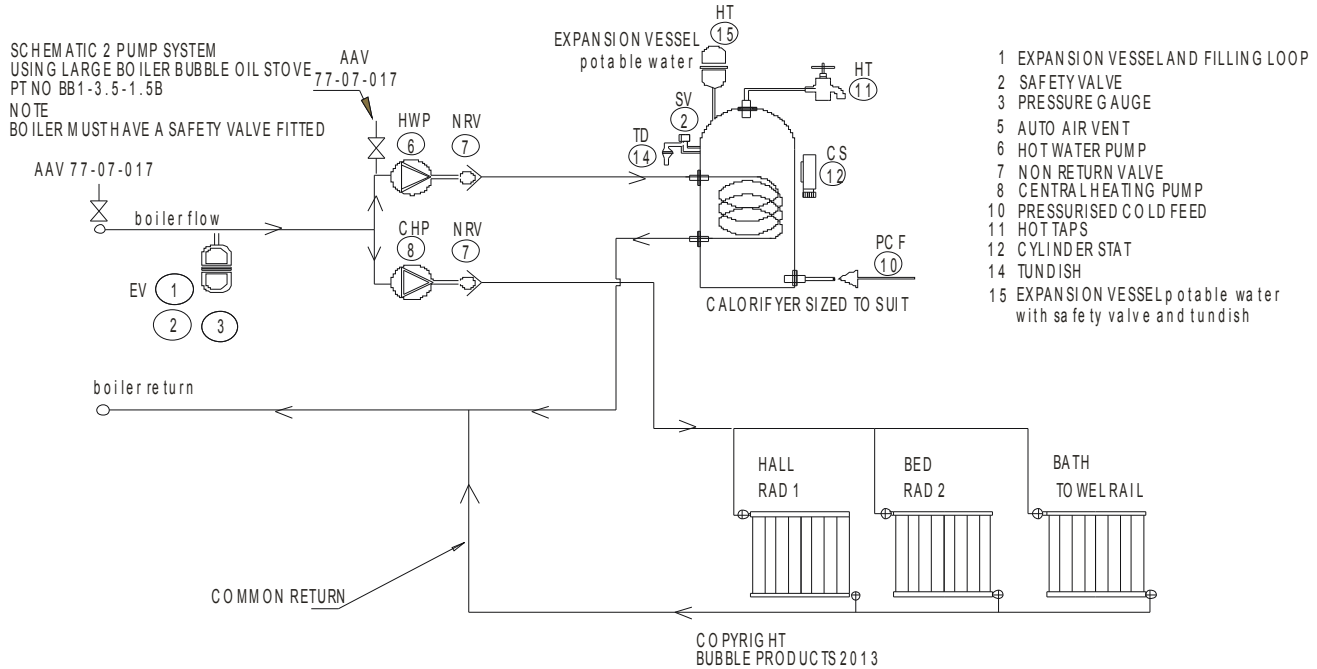

10. STOVE DIMENSIONS

10-1 BB1 HALF POD AND PIE POD DIMENSIONS

Note that the B1 Pie Pod has the same footprint dimensions but the vertical height is 830mm.

**B1 HALF OIL POD OF 12-02-15
OVERALL DIMENSIONS
BOILER AND NON BOILER VERSIONS**

**.WEIGHT 35.KG NON BOILER
.WEIGHT 45.KG SMALL BOILER
.WEIGHT 50.KG LARGE BOILER**

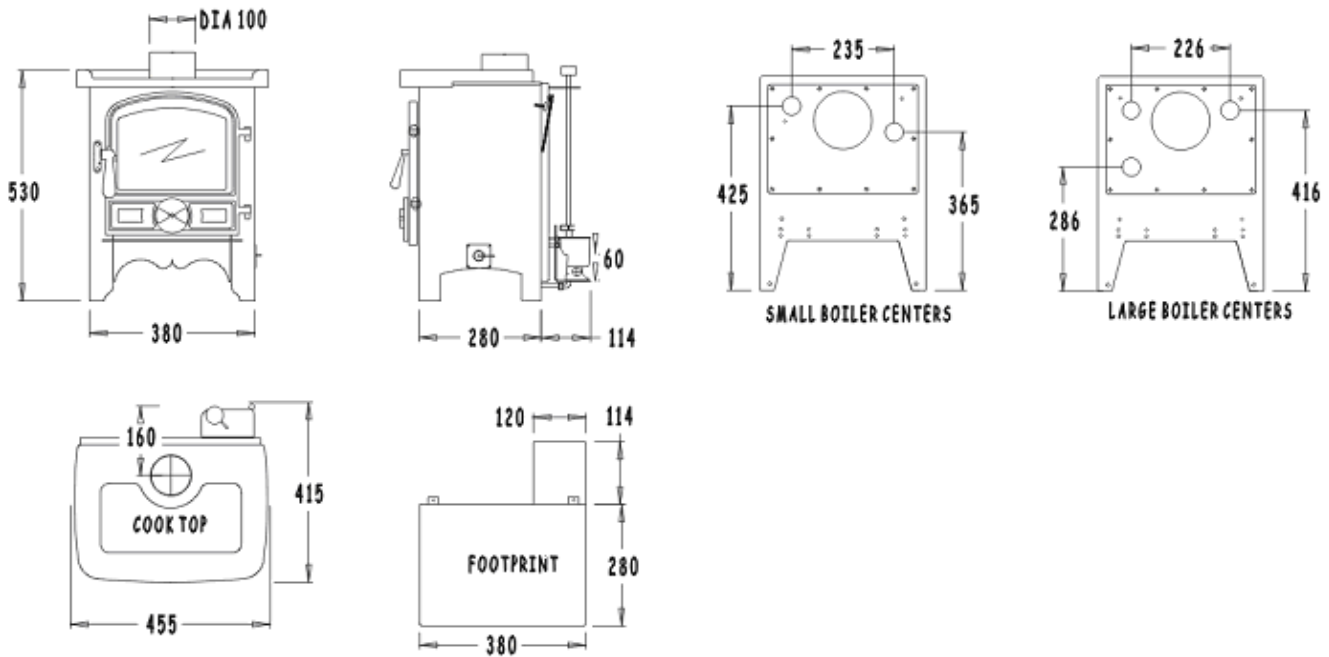

10-2 CORNER STOVE AND CORNER PIE POD DIMENSIONS

Note that the Corner Pie Pod has the same footprint dimensions but the vertical height is 840mm.

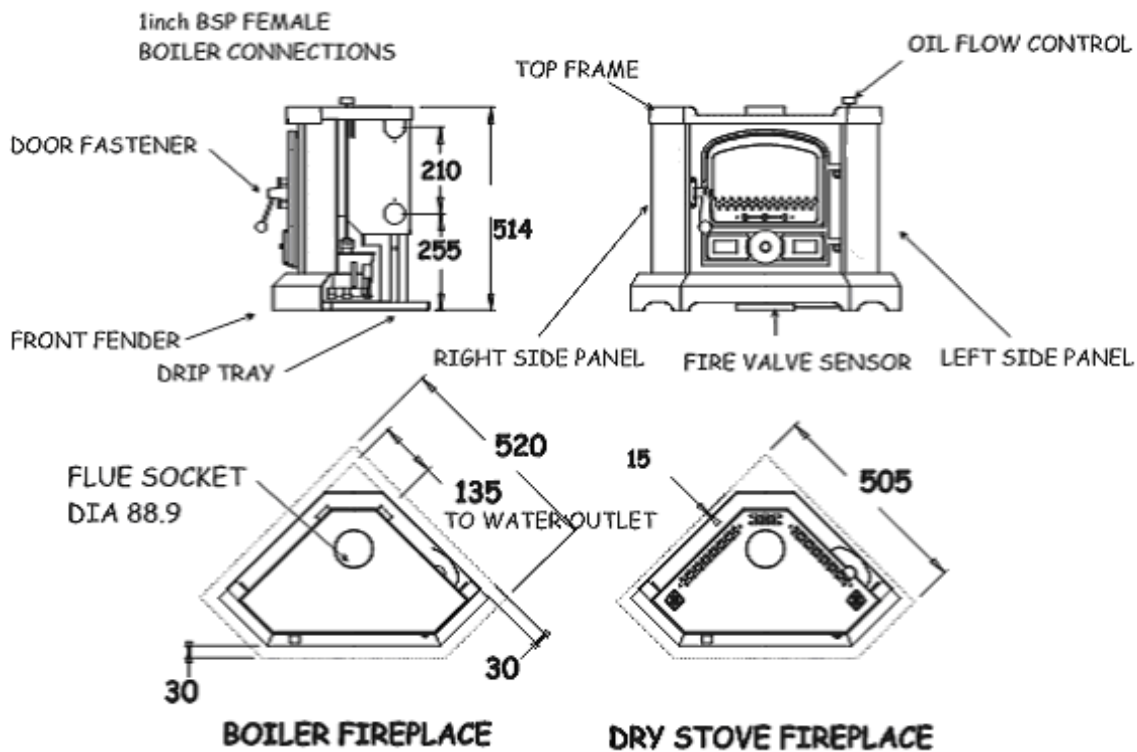

10-3 B2 STOVE DIMENSIONS

Note that the B2 Pie Pod has the same footprint dimensions but the vertical height is 830mm.

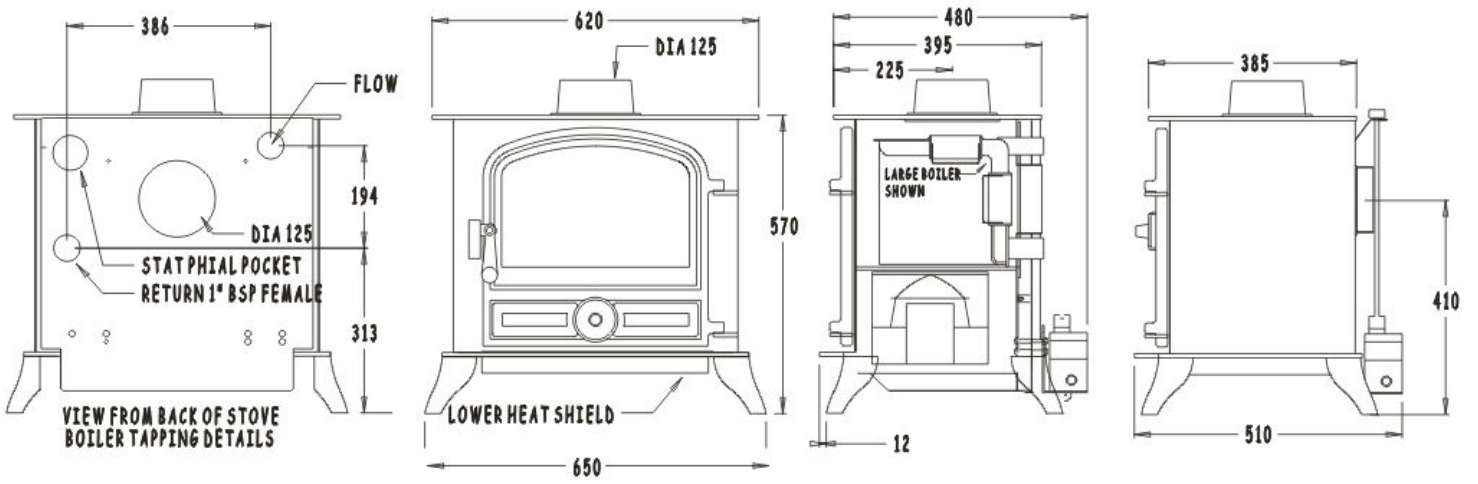

10-4 BACK CABIN COOKER DIMENSIONS

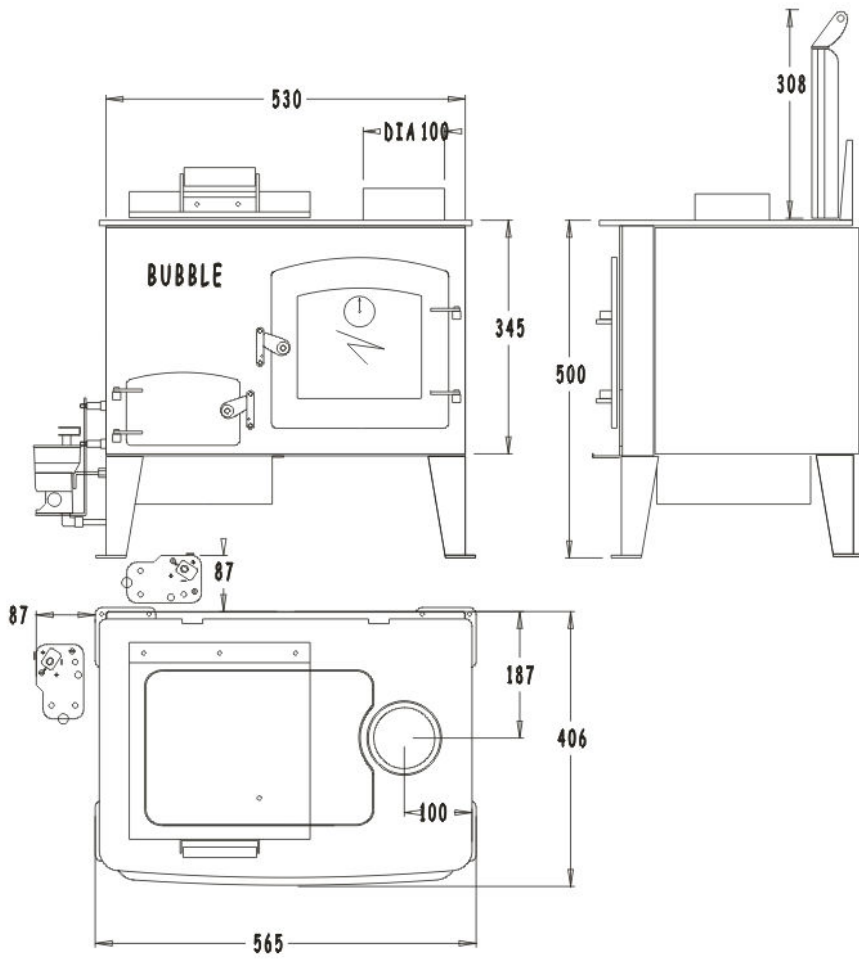

11. OIL CONSUMPTION RATES

		MAX HEAT OUTPUT TO WATER	MAX HEAT OUTPUT TO SPACE	MINIMUM OIL FLOW CC'S PER MIN	MAXIMUM OIL FLOW CC'S PER MINUTE
--	--	--------------------------	--------------------------	-------------------------------	----------------------------------

B1 HALF POD & OVEN DERIVATIVE

Free Standing	From 1.6kW to 5kW		5kW	4 = (1.6kW)	12 = (5kW)
Free Standing	From 1.6kW to 5kW	2kW	3kW	4 = (1.6kW)	12 = (5kW)
Free Standing	From 1.6kW to 6kW	5kW	2kW	4 = (1.6kW)	13 = (6kW)

CORNER STOVE & OVEN DERIVATIVE

Free Standing	From 1kW to 4kW		4kW	3 = (1kW)	10 = (4kW)
Free Standing	From 1kW to 4kW	3kW	1kW	3 = (1kW)	10 = (4kW)

BUBBLE 2

Free Standing	From 1.6kW to 5kW		5kW	4 = (1.6kW)	13 = (5kW)
Free Standing	From 1.6kW to 8kW		8kW	4 = (1.6kW)	16 = (8kW)
Free Standing	From 1.6kW to 8kW	3kW	5kW	4 = (1.6kW)	16 = (8kW)
Free Standing	From 1.6kW to 8kW	9kW	2kW	4 = (1.6kW)	22 = (11kW)

BACK CABIN COOKER

Free Standing	From 1.6kW to 5kW		3kW	4 = (1.6kW)	7 = (3kW)
Free Standing	From 1.6kW to 5kW	1kW	2kW	4 = (1.6kW)	7 = (3kW)

© HARWORTH HEATING LTD 30.6.98

This publication may not be copied by any means, without written permission from the authors.

These products are subject to continuous development and improvement and it is consequently acknowledged that due to this process there may be some omissions and errors.

This publication is intended only to assist the reader in the use of this product and therefore Harworth Heating Ltd shall not be liable for any loss or damage whatsoever arising from the use of any information, error or omission found in this publication.

The appliances mentioned in this publication can only be installed and serviced by approved personnel.

Approved personnel means that they must HAVE BEEN SUITABLY TRAINED, if there are any

reliability issues reported back to **Harworth Heating** or **Bubble Products**, the installing engineer will be responsible for carrying out any rectification work.

For details of suitable training courses contact: - www.oftec.org

12. NORMATIVE REFERENCES

Boat installation work comes under the control of: -
The Boat Safety Scheme.

This scheme provides statutory requirements and associated EN / BS Standards for most aspects of installation work on boats.

Further information and a copy of the requirements can be obtained from:-

www.boatsafetyscheme.com

Where guidance for oil fired appliances is not readily available from the Boat safety Scheme publication, we then point out a list of standards which pertain to domestic installations and which are generally covered by the latest version of the English Building Regulations Doc J.

When read in conjunction with:-

1. Our installation instructions.
2. The Boat Safety Scheme rules.
3. The other standards detailed, enough information should be provided to allow for a safe installation.

BS 5440	Flues.
BS 6999	Flues
BS 7840	Fuel Hoses.
BS EN1057	Copper Tubes.
BS1344 Part 3 1988 ISO8290 1987	Flues.
BS EN 1443:2003	Chimneys - General requirements.
BS EN1856 part 1 replacing BS 4543	Flues.
BS EN1856 part 2 & BS 715 1993	Flues.
BS 1945: 1971	Stove door
BS EN 10296-1	Steel tubes
BS ISO 10088:2001	
BS EN ISO 9094-2003	
BS EN 10297-1	Steel tubes
BS EN 13384-1	Chimneys
BS EN 10088-1:2005	Stainless steels - Part 1: List of stainless steels