

THERMOROSSI

FREE LINE WOOD COOKERS

ENG - INSTALLATION, USE AND MAINTENANCE GUIDE.



- KLARETTA EVO
- KLARISSA EVO
- VIOLETTA EVO
- MELISSA EVO
- KLARA EVO
- VIOLA EVO
- MARGOT EVO
- MARGHERITA EVO

ENG - Must read! Important information for safety and correct operation.



INDEX

1 – INTRODUCTION.....	7
2 – TECHNICAL CHARACTERISTICS.....	9
3 – GENERAL DESCRIPTION	12
4 – INSTALLATION.....	14
5 – ASSEMBLING THE COMPONENTS.....	16
6 – USE OF THE APPLIANCE	17
7 – CLEANING AND MAINTENANCE	20
8 – SMOKE EXHAUST TUBE	23
9 – PROBLEMS, CAUSES AND SOLUTIONS.....	25

EU Declaration of Conformity (DoC) / Dichiarazione di Conformità UE (DoC)

Company name: Azienda:	THERMOROSSI S.P.A.	Postal address: Indirizzo:	VIA GRUMOLO, N° 4
Postcode and city: Codice postale e città:	36011 ARSIERO (VI)	Telephone number: Numero di telefono:	0445/741310
E-mail address: Indirizzo e-mail:	INFO@THERMOROSSI.IT		

declare that the DoC is issued under our sole responsibility and belongs to the following product:
dichiara che la dichiarazione viene rilasciata sotto la propria responsabilità e si riferisce al seguente prodotto:

Apparatus model / Product: Descrizione prodotto:	Stufa a legna Wood stove	Trademark: Marchio:	THERMOROSSI
---	-----------------------------	------------------------	-------------

Models: Modelli:	KLARETTA EVO – VIOLETTA EVO KLARISSA EVO – MELISSA EVO KLARA EVO – MARGOT EVO VIOLA EVO – MARGHERITA EVO
---------------------	---

Sono state applicate le seguenti norme armonizzate e/o specifiche tecniche:
The following harmonised standards and/or technical specifications have been applied: **EN 13240:2001**

The tests carried out by the notified laboratory Kiwa Cermet Italia S.p.a (N.B. 0476) - 31020 San Vendemiano (TV).

Arsiero, 28/06/2024

Firma/Sign.



THERMOROSSI S.P.A.
Un'Amministrazione

THERMOROSSI <i>Fire Stoves</i>		DICHIARAZIONE DI PRESTAZIONE IN ACCORDO CON IL REGOLAMENTO (UE) 305/2011 DECLARATION OF PERFORMANCE ACCORDING TO REGULATION (EU) 305/2011		N° 77A		
1	Codice di identificazione unico del prodotto-tipo: KLARETTA EVO <i>Unique identification code of the product type:</i>	2	Modello, lotto, serie ai sensi dell'articolo 11, paragrafo 4: KLARETTA EVO <i>Model, batch or serial number required under Article 11 (4):</i>			
3	Usi previsti del prodotto da costruzione, conformemente alla relativa specifica tecnica armonizzata: <i>Intended uses of the construction product, in accordance with the applicable harmonised technical specification:</i> Apparecchio per il riscaldamento domestico, senza acqua, alimentato a ceppi di legna / Residential space heating appliance, without water, fired by wood logs					
4	Nome registrato e indirizzo del fabbricante ai sensi dell'articolo 11, paragrafo 5: <i>Name and contact address of the manufacturer as required pursuant to Article 11 (5):</i> THERMOROSSI S.P.A. Via Grumolo, n° 4 36011 Arsiero (Vicenza)	5	Nome e indirizzo del mandatario ai sensi dell'articolo 12, paragrafo 2: <i>Name and address of the agent as required pursuant to Article 12 (2):</i> -			
6	Sistema di valutazione e verifica della costanza della prestazione del prodotto da costruzione di cui all'allegato V: Sistema 3 <i>System of assessment and verification of constancy of performance of the construction product as set out in Annex V: System 3</i>					
7	Laboratorio notificato: <i>Notified laboratory:</i> KIWA CERMET ITALIA S.p.A. N° 0476	Numero del rapporto di prova secondo il sistema 3 / Test report number based on System 3: 2011253				
Prestazione dichiarata / Declared performance						
Specifica tecnica armonizzata/ <i>Harmonized technical specification:</i>			EN 13240:2001/A1			
Caratteristiche Essenziali / <i>Essential characteristics</i>			Prestazione / Performance			
Reazione al fuoco / <i>Reaction to fire</i>			A1			
Distanza da materiali combustibili <i>Distance to combustible materials</i>			Minime distanze / <i>Minimum distances</i> (mm): posteriore/rear = 300 lati/sides = 300 frontale/front = 800 soffitto/ceiling = - pavimento/floor = -			
Rischio di fuoriuscita di braci incandescenti / <i>Risk of burning fuel falling out</i>			Conforme/Compliant			
Temperatura superficiale / <i>Surface temperature</i>			Conforme/Compliant			
Sicurezza elettrica / <i>Electrical safety</i>			-			
8	Pulizia / <i>Cleanability</i>		Conforme/Compliant			
Emissione di prodotti della combustione / <i>Emission of combustion products</i>			CO = 324 mg/m³ a potenza termica nominale / <i>CO at Nominal heat output</i>			
Pressione massima di esercizio / <i>Maximum operating pressure</i>			- bar			
Temperatura fumi a potenza termica nominale / <i>Flue gas temperature at nominal heat output</i>			T 203 °C			
Resistenza meccanica (per sopportare il camino) / <i>Mechanical resistance (to carry a chimney)</i>			NPD {Nessuna Prestazione Determinata/No Performance Determined}			
Potenza termica nominale / <i>Nominal heat output</i>			8.2 kW			
Potenza termica resa in ambiente / <i>Room heating output</i>			8.2 kW			
Potenza termica ceduta all'acqua / <i>Water heating output</i>			-.- kW			
Rendimento / <i>Efficiency</i>			87,4% alla potenza termica nominale / <i>Nominal heat output</i>			
9	La prestazione del prodotto di cui ai punti 1 e 2 è conforme alla prestazione dichiarata di cui al punto 8. Si rilascia la presente dichiarazione di prestazione sotto la responsabilità esclusiva del fabbricante di cui al punto 4. <i>The performance of the product identified in points 1 and 2 is in conformity with the declared performance in point 8. This declaration of performance is issued under the sole responsibility of the manufacturer identified in point 4.</i> Arsiero, 31/01/2022				Firma / <i>Signature:</i>  THERMOROSSI S.P.A. <i>Un Amministratore</i>	

THERMOROSSI <i>Fire Stoves</i>		DICHIARAZIONE DI PRESTAZIONE IN ACCORDO CON IL REGOLAMENTO (UE) 305/2011 DECLARATION OF PERFORMANCE ACCORDING TO REGULATION (EU) 305/2011		N° 122		
1	Codice di identificazione unico del prodotto-tipo: KLARISSA EVO <i>Unique identification code of the product type:</i>	2	Modello, lotto, serie ai sensi dell'articolo 11, paragrafo 4: KLARISSA EVO <i>Model, batch or serial number required under Article 11 (4):</i>			
3	Usi previsti del prodotto da costruzione, conformemente alla relativa specifica tecnica armonizzata: <i>Intended uses of the construction product, in accordance with the applicable harmonised technical specification:</i> Apparecchio per il riscaldamento domestico, senza acqua, alimentato a ceppi di legna / Residential space heating appliance without water fired by wood logs					
4	Nome registrato e indirizzo del fabbricante ai sensi dell'articolo 11, paragrafo 5: <i>Name and contact address of the manufacturer as required pursuant Article 11 (5):</i> THERMOROSSI S.P.A. Via Grumolo, n° 4 36011 Arsiero (VI)	5	Nome e indirizzo del mandatario ai sensi dell'articolo 12, paragrafo 2: <i>Name and address of the agent as required pursuant Article 12 (2):</i> -			
6	Sistema di valutazione e verifica della costanza della prestazione del prodotto da costruzione di cui all'allegato V: Sistema 3 <i>System of assessment and verification of constancy of performance of the construction product as set out in Annex V: System 3</i>					
7	Laboratorio notificato: <i>Notified laboratory:</i> KIWA CERMET ITALIA S.p.A. N° 0476	Numero del rapporto di prova secondo il sistema 3 / Test report number based on System 3: 2011253/01				
Prestazione dichiarata / Declared performance						
Specifica tecnica armonizzata/ <i>Harmonized technical specification:</i>			EN 13240:2001			
Caratteristiche Essenziali / <i>Essential characteristics</i>			Prestazione / Performance			
Reazione al fuoco / <i>Reaction to fire</i>			A1			
Distanza da materiali combustibili <i>Distance to combustible materials</i>			Minime distanze / <i>Minimum distances</i> (mm): posteriore/rear = 300 lati/sides = 300 frontale / front = 800 soffitto/ceiling = - pavimento / floor = -			
Rischio di fuoriuscita di braci incandescenti / <i>Risk of burning fuel falling out</i>			Conforme/Compliant			
Temperatura superficiale/ <i>Surface temperature</i>			Conforme/Compliant			
Sicurezza elettrica / <i>Electrical safety</i>			-			
8	Pulizia / <i>Cleanability</i>		Conforme/Compliant			
Emissione di prodotti della combustione / <i>Emission of combustion products</i>			CO = 324 mg/m³ a potenza termica nominale / <i>CO at Nominal heat output</i>			
Pressione massima di esercizio / <i>Maximum operating pressure</i>			- bar			
Temperatura fumi a potenza termica nominale / <i>Flue gas temperature at nominal heat output</i>			T 203 °C			
Resistenza meccanica (per sopportare il camino) / <i>Mechanical resistance (to carry a chimney)</i>			NPD {Nessuna Prestazione Determinata}			
Potenza termica nominale / <i>Nominal heat output</i>			8,2 kW			
Potenza termica resa in ambiente / <i>Room heating output</i>			8,2 kW			
Potenza termica ceduta all'acqua / <i>Water heating output</i>			-.- kW			
Rendimento / <i>Efficiency</i>			87,4% alla potenza termica nominale / <i>Nominal heat output</i>			
9	La prestazione del prodotto di cui ai punti 1 e 2 è conforme alla prestazione dichiarata di cui al punto 8. Si rilascia la presente dichiarazione di prestazione sotto la responsabilità esclusiva del fabbricante di cui al punto 4. <i>The performance of the product identified in points 1 and 2 is in conformity with the declared performance in point 8. This declaration of performance is issued under the sole responsibility of the manufacturer identified in point 4.</i> Arsiero, 28/06/2024				Firma:  THERMOROSSI S.P.A. <i>Un Amministratore</i>	

THERMOROSSI <i>Fire Lovers</i>		DICHIARAZIONE DI PRESTAZIONE IN ACCORDO CON IL REGOLAMENTO (UE) 305/2011 DECLARATION OF PERFORMANCE ACCORDING TO REGULATION (EU) 305/2011		N° 78A		
1	Codice di identificazione unico del prodotto-tipo: VIOLETTA EVO <i>Unique identification code of the product type:</i>	2	Modello, lotto, serie ai sensi dell'articolo 11, paragrafo 4: VIOLETTA EVO <i>Model, batch or serial number required under Article 11 (4):</i>			
3	Usi previsti del prodotto da costruzione, conformemente alla relativa specifica tecnica armonizzata: <i>Intended uses of the construction product, in accordance with the applicable harmonised technical specification:</i> Apparecchio per il riscaldamento domestico, senza acqua, alimentato a ceppi di legna / Residential space heating appliance, without water, fired by wood logs					
4	Nome registrato e indirizzo del fabbricante ai sensi dell'articolo 11, paragrafo 5: <i>Name and contact address of the manufacturer as required pursuant to Article 11 (5):</i> THERMOROSSI S.P.A. Via Grumolo, n° 4 36011 Arsiero (Vicenza)	5	Nome e indirizzo del mandatario ai sensi dell'articolo 12, paragrafo 2: <i>Name and address of the agent as required pursuant to Article 12 (2):</i> -			
6	Sistema di valutazione e verifica della costanza della prestazione del prodotto da costruzione di cui all'allegato V: Sistema 3 <i>System of assessment and verification of constancy of performance of the construction product as set out in Annex V: System 3</i>					
7	Laboratorio notificato: <i>Notified laboratory:</i> KIWA CERMET ITALIA S.p.A. N° 0476	Numero del rapporto di prova secondo il sistema 3 / Test report number based on System 3: 2011253				
Prestazione dichiarata / Declared performance						
<i>Specifica tecnica armonizzata/Harmonized technical specification:</i>			EN 13240:2001/A1			
<i>Caratteristiche Essenziali / Essential characteristics</i>			Prestazione / Performance			
<i>Reazione al fuoco / Reaction to fire</i>			A1			
<i>Distanza da materiali combustibili Distance to combustible materials</i>			Minime distanze / <i>Minimum distances</i> (mm): posteriore/rear = 300 lati/sides = 300 frontale/front = 800 soffitto/ceiling = - pavimento/floor = -			
<i>Rischio di fuoriuscita di braci incandescenti / Risk of burning fuel falling out</i>			Conforme/Compliant			
<i>Temperatura superficiale / Surface temperature</i>			Conforme/Compliant			
<i>Sicurezza elettrica / Electrical safety</i>			-			
<i>Pulizia / Cleanability</i>			Conforme/Compliant			
<i>Emissione di prodotti della combustione / Emission of combustion products</i>			CO = 324 mg/m³ a potenza termica nominale / <i>CO at Nominal heat output</i>			
<i>Pressione massima di esercizio / Maximum operating pressure</i>			- bar			
<i>Temperatura fumi a potenza termica nominale / Flue gas temperature at nominal heat output</i>			T 203 °C			
<i>Resistenza meccanica (per sopportare il camino) / Mechanical resistance (to carry a chimney)</i>			NPD (Nessuna Prestazione Determinata/No Performance Determined)			
<i>Potenza termica nominale / Nominal heat output</i>			8,2 kW			
<i>Potenza termica resa in ambiente / Room heating output</i>			8,2 kW			
<i>Potenza termica ceduta all'acqua / Water heating output</i>			- kW			
<i>Rendimento / Efficiency</i>			87,4% alla potenza termica nominale / <i>Nominal heat output</i>			
9	La prestazione del prodotto di cui ai punti 1 e 2 è conforme alla prestazione dichiarata di cui al punto 8. Si rilascia la presente dichiarazione di prestazione sotto la responsabilità esclusiva del fabbricante di cui al punto 4. <i>The performance of the product identified in points 1 and 2 is in conformity with the declared performance in point 8. This declaration of performance is issued under the sole responsibility of the manufacturer identified in point 4.</i> Arsiero, 31/01/2022				Firma / <i>Signature:</i> 	

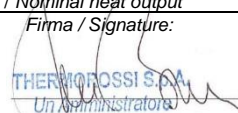
THERMOROSSI <i>Fire Lovers</i>		DICHIARAZIONE DI PRESTAZIONE IN ACCORDO CON IL REGOLAMENTO (UE) 305/2011 DECLARATION OF PERFORMANCE ACCORDING TO REGULATION (EU) 305/2011		N° 123		
1	Codice di identificazione unico del prodotto-tipo: MELISSA EVO <i>Unique identification code of the product type:</i>	2	Modello, lotto, serie ai sensi dell'articolo 11, paragrafo 4: MELISSA EVO <i>Model, batch or serial number required under Article 11 (4):</i>			
3	Usi previsti del prodotto da costruzione, conformemente alla relativa specifica tecnica armonizzata: <i>Intended uses of the construction product, in accordance with the applicable harmonised technical specification:</i> Apparecchio per il riscaldamento domestico, senza acqua, alimentato a ceppi di legna / Residential space heating appliance without water fired by wood logs					
4	Nome registrato e indirizzo del fabbricante ai sensi dell'articolo 11, paragrafo 5: <i>Name and contact address of the manufacturer as required pursuant to Article 11 (5):</i> THERMOROSSI S.P.A. Via Grumolo, n° 4 36011 Arsiero (VI)	5	Nome e indirizzo del mandatario ai sensi dell'articolo 12, paragrafo 2: <i>Name and address of the agent as required pursuant to Article 12 (2):</i> -			
6	Sistema di valutazione e verifica della costanza della prestazione del prodotto da costruzione di cui all'allegato V: Sistema 3 <i>System of assessment and verification of constancy of performance of the construction product as set out in Annex V: System 3</i>					
7	Laboratorio notificato: <i>Notified laboratory:</i> KIWA CERMET ITALIA S.p.A. N° 0476	Numero del rapporto di prova secondo il sistema 3 / Test report number based on System 3: 2011253/01				
Prestazione dichiarata / Declared performance						
<i>Specifica tecnica armonizzata/Harmonized technical specification:</i>			EN 13240:2001			
<i>Caratteristiche Essenziali / Essential characteristics</i>			Prestazione / Performance			
<i>Reazione al fuoco / Reaction to fire</i>			A1			
<i>Distanza da materiali combustibili Distance to combustible materials</i>			Minime distanze / <i>Minimum distances</i> (mm): posteriore/rear = 300 lati/sides = 300 frontale / front = 800 soffitto/ceiling = - pavimento / floor = -			
<i>Rischio di fuoriuscita di braci incandescenti / Risk of burning fuel falling out</i>			Conforme/Compliant			
<i>Temperatura superficiale/Surface temperature</i>			Conforme/Compliant			
<i>Sicurezza elettrica / Electrical safety</i>			-			
<i>Pulizia / Cleanability</i>			Conforme/Compliant			
<i>Emissione di prodotti della combustione /Emission of combustion products</i>			CO = 324 mg/m³ a potenza termica nominale / <i>CO at Nominal heat output</i>			
<i>Pressione massima di esercizio / Maximum operating pressure</i>			- bar			
<i>Temperatura fumi a potenza termica nominale / Flue gas temperature at nominal heat output</i>			T 203 °C			
<i>Resistenza meccanica (per sopportare il camino) / Mechanical resistance (to carry a chimney)</i>			NPD (Nessuna Prestazione Determinata)			
<i>Potenza termica nominale / Nominal heat output</i>			8,2 kW			
<i>Potenza termica resa in ambiente / Room heating output</i>			8,2 kW			
<i>Potenza termica ceduta all'acqua / Water heating output</i>			- kW			
<i>Rendimento / Efficiency</i>			87,4% alla potenza termica nominale / <i>Nominal heat output</i>			
9	La prestazione del prodotto di cui ai punti 1 e 2 è conforme alla prestazione dichiarata di cui al punto 8. Si rilascia la presente dichiarazione di prestazione sotto la responsabilità esclusiva del fabbricante di cui al punto 4. <i>The performance of the product identified in points 1 and 2 is in conformity with the declared performance in point 8. This declaration of performance is issued under the sole responsibility of the manufacturer identified in point 4.</i> Arsiero, 28/06/2024				Firma: 	

THERMOROSSI <i>Fire Lovers</i>		DICHIARAZIONE DI PRESTAZIONE IN ACCORDO CON IL REGOLAMENTO (UE) 305/2011 DECLARATION OF PERFORMANCE ACCORDING TO REGULATION (EU) 305/2011		N° 79B		
1	Codice di identificazione unico del prodotto-tipo: KLARA EVO <i>Unique identification code of the product type:</i>	2	Modello, lotto, serie ai sensi dell'articolo 11, paragrafo 4: KLARA EVO <i>Model, batch or serial number required under Article 11 (4):</i>			
3	Usi previsti del prodotto da costruzione, conformemente alla relativa specifica tecnica armonizzata: <i>Intended uses of the construction product, in accordance with the applicable harmonised technical specification:</i> Apparecchio per il riscaldamento domestico, senza acqua, alimentato a ceppi di legna / Residential space heating appliance, without water, fired by wood logs					
4	Nome registrato e indirizzo del fabbricante ai sensi dell'articolo 11, paragrafo 5: <i>Name and contact address of the manufacturer as required pursuant to Article 11 (5):</i> THERMOROSSI S.P.A. Via Grumolo, n° 4 36011 Arsiero (Vicenza)	5	Nome e indirizzo del mandatario ai sensi dell'articolo 12, paragrafo 2: <i>Name and address of the agent as required pursuant to Article 12 (2):</i> -			
6	Sistema di valutazione e verifica della costanza della prestazione del prodotto da costruzione di cui all'allegato V: Sistema 3 <i>System of assessment and verification of constancy of performance of the construction product as set out in Annex V: System 3</i>					
7	Laboratorio notificato: <i>Notified laboratory:</i> KIWA CERMET ITALIA S.p.A. N° 0476	Numero del rapporto di prova secondo il sistema 3 / Test report number based on System 3: 2004694/01				
Prestazione dichiarata / Declared performance						
Specifica tecnica armonizzata/ <i>Harmonized technical specification:</i>			EN 13240:2001/A1			
Caratteristiche Essenziali / <i>Essential characteristics</i>			Prestazione / Performance			
Reazione al fuoco / <i>Reaction to fire</i>			A1			
Distanza da materiali combustibili <i>Distance to combustible materials</i>			Minime distanze / <i>Minimum distances</i> (mm): posteriore/rear = 300 lati/sides = 300 frontale/front = 800 soffitto/ceiling = - pavimento/floor = -			
Rischio di fuoriuscita di braci incandescenti / <i>Risk of burning fuel falling out</i>			Conforme/Compliant			
Temperatura superficiale / <i>Surface temperature</i>			Conforme/Compliant			
Sicurezza elettrica / <i>Electrical safety</i>			-			
8	Pulizia / <i>Cleanability</i>			Conforme/Compliant		
Emissione di prodotti della combustione / <i>Emission of combustion products</i>			CO = 387 mg/m3 a potenza termica nominale / <i>CO at Nominal heat output</i>			
Pressione massima di esercizio / <i>Maximum operating pressure</i>			- bar			
Temperatura fumi a potenza termica nominale / <i>Flue gas temperature at nominal heat output</i>			T 224 °C			
Resistenza meccanica (per sopportare il camino) / <i>Mechanical resistance (to carry a chimney)</i>			NPD (Nessuna Prestazione Determinata/No Performance Determined)			
Potenza termica nominale / <i>Nominal heat output</i>			12.1 kW			
Potenza termica resa in ambiente / <i>Room heating output</i>			12.1 kW			
Potenza termica ceduta all'acqua / <i>Water heating output</i>			-- kW			
Rendimento / <i>Efficiency</i>			86,7% alla potenza termica nominale / <i>Nominal heat output</i>			
9	La prestazione del prodotto di cui ai punti 1 e 2 è conforme alla prestazione dichiarata di cui al punto 8. Si rilascia la presente dichiarazione di prestazione sotto la responsabilità esclusiva del fabbricante di cui al punto 4. <i>The performance of the product identified in points 1 and 2 is in conformity with the declared performance in point 8. This declaration of performance is issued under the sole responsibility of the manufacturer identified in point 4.</i> Arsiero, 31/01/2022				Firma / <i>Signature:</i> 	

THERMOROSSI <i>Fire Lovers</i>		DICHIARAZIONE DI PRESTAZIONE IN ACCORDO CON IL REGOLAMENTO (UE) 305/2011 DECLARATION OF PERFORMANCE ACCORDING TO REGULATION (EU) 305/2011		N° 80B		
1	Codice di identificazione unico del prodotto-tipo: VIOLA EVO <i>Unique identification code of the product type:</i>	2	Modello, lotto, serie ai sensi dell'articolo 11, paragrafo 4: VIOLA EVO <i>Model, batch or serial number required under Article 11 (4):</i>			
3	Usi previsti del prodotto da costruzione, conformemente alla relativa specifica tecnica armonizzata: <i>Intended uses of the construction product, in accordance with the applicable harmonised technical specification:</i> Apparecchio per il riscaldamento domestico, senza acqua, alimentato a ceppi di legna / Residential space heating appliance, without water, fired by wood logs					
4	Nome registrato e indirizzo del fabbricante ai sensi dell'articolo 11, paragrafo 5: <i>Name and contact address of the manufacturer as required pursuant to Article 11 (5):</i> THERMOROSSI S.P.A. Via Grumolo, n° 4 36011 Arsiero (Vicenza)	5	Nome e indirizzo del mandatario ai sensi dell'articolo 12, paragrafo 2: <i>Name and address of the agent as required pursuant to Article 12 (2):</i> -			
6	Sistema di valutazione e verifica della costanza della prestazione del prodotto da costruzione di cui all'allegato V: Sistema 3 <i>System of assessment and verification of constancy of performance of the construction product as set out in Annex V: System 3</i>					
7	Laboratorio notificato: <i>Notified laboratory:</i> KIWA CERMET ITALIA S.p.A. N° 0476	Numero del rapporto di prova secondo il sistema 3 / Test report number based on System 3: 2004694/01				
Prestazione dichiarata / Declared performance						
Specifica tecnica armonizzata/ <i>Harmonized technical specification:</i>			EN 13240:2001/A1			
Caratteristiche Essenziali / <i>Essential characteristics</i>			Prestazione / Performance			
Reazione al fuoco / <i>Reaction to fire</i>			A1			
Distanza da materiali combustibili <i>Distance to combustible materials</i>			Minime distanze / <i>Minimum distances</i> (mm): posteriore/rear = 300 lati/sides = 300 frontale/front = 800 soffitto/ceiling = - pavimento/floor = -			
Rischio di fuoriuscita di braci incandescenti / <i>Risk of burning fuel falling out</i>			Conforme/Compliant			
Temperatura superficiale / <i>Surface temperature</i>			Conforme/Compliant			
Sicurezza elettrica / <i>Electrical safety</i>			-			
8	Pulizia / <i>Cleanability</i>			Conforme/Compliant		
Emissione di prodotti della combustione / <i>Emission of combustion products</i>			CO = 387 mg/m3 a potenza termica nominale / <i>CO at Nominal heat output</i>			
Pressione massima di esercizio / <i>Maximum operating pressure</i>			- bar			
Temperatura fumi a potenza termica nominale / <i>Flue gas temperature at nominal heat output</i>			T 224 °C			
Resistenza meccanica (per sopportare il camino) / <i>Mechanical resistance (to carry a chimney)</i>			NPD (Nessuna Prestazione Determinata/No Performance Determined)			
Potenza termica nominale / <i>Nominal heat output</i>			12.1 kW			
Potenza termica resa in ambiente / <i>Room heating output</i>			12.1 kW			
Potenza termica ceduta all'acqua / <i>Water heating output</i>			-- kW			
Rendimento / <i>Efficiency</i>			86,7% alla potenza termica nominale / <i>Nominal heat output</i>			
9	La prestazione del prodotto di cui ai punti 1 e 2 è conforme alla prestazione dichiarata di cui al punto 8. Si rilascia la presente dichiarazione di prestazione sotto la responsabilità esclusiva del fabbricante di cui al punto 4. <i>The performance of the product identified in points 1 and 2 is in conformity with the declared performance in point 8. This declaration of performance is issued under the sole responsibility of the manufacturer identified in point 4.</i> Arsiero, 31/01/2022				Firma / <i>Signature:</i> 	

THERMOROSSI <i>Fire Stoves</i>		DICHIARAZIONE DI PRESTAZIONE IN ACCORDO CON IL REGOLAMENTO (UE) 305/2011 DECLARATION OF PERFORMANCE ACCORDING TO REGULATION (EU) 305/2011		N° 81B		
1	Codice di identificazione unico del prodotto-tipo: MARGOT EVO <i>Unique identification code of the product type:</i>	2	Modello, lotto, serie ai sensi dell'articolo 11, paragrafo 4: MARGOT EVO <i>Model, batch or serial number required under Article 11 (4):</i>			
3	Usi previsti del prodotto da costruzione, conformemente alla relativa specifica tecnica armonizzata: <i>Intended uses of the construction product, in accordance with the applicable harmonised technical specification:</i> Apparecchio per il riscaldamento domestico, senza acqua, alimentato a ceppi di legna / Residential space heating appliance, without water, fired by wood logs					
4	Nome registrato e indirizzo del fabbricante ai sensi dell'articolo 11, paragrafo 5: <i>Name and contact address of the manufacturer as required pursuant to Article 11 (5):</i> THERMOROSSI S.P.A. Via Grumolo, n° 4 36011 Arsiero (Vicenza)	5	Nome e indirizzo del mandatario ai sensi dell'articolo 12, paragrafo 2: <i>Name and address of the agent as required pursuant to Article 12 (2):</i> -			
6	Sistema di valutazione e verifica della costanza della prestazione del prodotto da costruzione di cui all'allegato V: Sistema 3 <i>System of assessment and verification of constancy of performance of the construction product as set out in Annex V: System 3</i>					
7	Laboratorio notificato: <i>Notified laboratory:</i> KIWA CERMET ITALIA S.p.A. N° 0476	Numero del rapporto di prova secondo il sistema 3 / Test report number based on System 3: 2004694/01				
Prestazione dichiarata / Declared performance						
Specifica tecnica armonizzata/ <i>Harmonized technical specification:</i>			EN 13240:2001/A1			
Caratteristiche Essenziali / <i>Essential characteristics</i>			Prestazione / Performance			
Reazione al fuoco / <i>Reaction to fire</i>			A1			
Distanza da materiali combustibili <i>Distance to combustible materials</i>			Minime distanze / <i>Minimum distances</i> (mm): posteriore/rear = 300 lati/sides = 300 frontale/front = 800 soffitto/ceiling = - pavimento/floor = -			
Rischio di fuoriuscita di braci incandescenti / <i>Risk of burning fuel falling out</i>			Conforme/Compliant			
Temperatura superficiale / <i>Surface temperature</i>			Conforme/Compliant			
Sicurezza elettrica / <i>Electrical safety</i>			-			
8	Pulizia / <i>Cleanability</i>			Conforme/Compliant		
Emissione di prodotti della combustione / <i>Emission of combustion products</i>			CO = 387 mg/m3 a potenza termica nominale / <i>CO at Nominal heat output</i>			
Pressione massima di esercizio / <i>Maximum operating pressure</i>			- bar			
Temperatura fumi a potenza termica nominale / <i>Flue gas temperature at nominal heat output</i>			T 224 °C			
Resistenza meccanica (per sopportare il camino) / <i>Mechanical resistance (to carry a chimney)</i>			NPD (Nessuna Prestazione Determinata/No Performance Determined)			
Potenza termica nominale / <i>Nominal heat output</i>			12.1 kW			
Potenza termica resa in ambiente / <i>Room heating output</i>			12.1 kW			
Potenza termica ceduta all'acqua / <i>Water heating output</i>			-- kW			
Rendimento / <i>Efficiency</i>			86,7% alla potenza termica nominale / <i>Nominal heat output</i>			
9	La prestazione del prodotto di cui ai punti 1 e 2 è conforme alla prestazione dichiarata di cui al punto 8. Si rilascia la presente dichiarazione di prestazione sotto la responsabilità esclusiva del fabbricante di cui al punto 4. <i>The performance of the product identified in points 1 and 2 is in conformity with the declared performance in point 8. This declaration of performance is issued under the sole responsibility of the manufacturer identified in point 4.</i> Arsiero, 31/01/2022				Firma / <i>Signature:</i> 	

THERMOROSSI <i>Fire Stoves</i>		DICHIARAZIONE DI PRESTAZIONE IN ACCORDO CON IL REGOLAMENTO (UE) 305/2011 DECLARATION OF PERFORMANCE ACCORDING TO REGULATION (EU) 305/2011		N° 82B		
1	Codice di identificazione unico del prodotto-tipo: MARGHERITA EVO <i>Unique identification code of the product type:</i>	2	Modello, lotto, serie ai sensi dell'articolo 11, paragrafo 4: MARGHERITA EVO <i>Model, batch or serial number required under Article 11 (4):</i>			
3	Usi previsti del prodotto da costruzione, conformemente alla relativa specifica tecnica armonizzata: <i>Intended uses of the construction product, in accordance with the applicable harmonised technical specification:</i> Apparecchio per il riscaldamento domestico, senza acqua, alimentato a ceppi di legna / Residential space heating appliance, without water, fired by wood logs					
4	Nome registrato e indirizzo del fabbricante ai sensi dell'articolo 11, paragrafo 5: <i>Name and contact address of the manufacturer as required pursuant to Article 11 (5):</i> THERMOROSSI S.P.A. Via Grumolo, n° 4 36011 Arsiero (Vicenza)	5	Nome e indirizzo del mandatario ai sensi dell'articolo 12, paragrafo 2: <i>Name and address of the agent as required pursuant to Article 12 (2):</i> -			
6	Sistema di valutazione e verifica della costanza della prestazione del prodotto da costruzione di cui all'allegato V: Sistema 3 <i>System of assessment and verification of constancy of performance of the construction product as set out in Annex V: System 3</i>					
7	Laboratorio notificato: <i>Notified laboratory:</i> KIWA CERMET ITALIA S.p.A. N° 0476	Numero del rapporto di prova secondo il sistema 3 / Test report number based on System 3: 2004694/01				
Prestazione dichiarata / Declared performance						
Specifica tecnica armonizzata/ <i>Harmonized technical specification:</i>			EN 13240:2001/A1			
Caratteristiche Essenziali / <i>Essential characteristics</i>			Prestazione / Performance			
Reazione al fuoco / <i>Reaction to fire</i>			A1			
Distanza da materiali combustibili <i>Distance to combustible materials</i>			Minime distanze / <i>Minimum distances</i> (mm): posteriore/rear = 300 lati/sides = 300 frontale/front = 800 soffitto/ceiling = - pavimento/floor = -			
Rischio di fuoriuscita di braci incandescenti / <i>Risk of burning fuel falling out</i>			Conforme/Compliant			
Temperatura superficiale / <i>Surface temperature</i>			Conforme/Compliant			
Sicurezza elettrica / <i>Electrical safety</i>			-			
8	Pulizia / <i>Cleanability</i>			Conforme/Compliant		
Emissione di prodotti della combustione / <i>Emission of combustion products</i>			CO = 387 mg/m3 a potenza termica nominale / <i>CO at Nominal heat output</i>			
Pressione massima di esercizio / <i>Maximum operating pressure</i>			- bar			
Temperatura fumi a potenza termica nominale / <i>Flue gas temperature at nominal heat output</i>			T 224 °C			
Resistenza meccanica (per sopportare il camino) / <i>Mechanical resistance (to carry a chimney)</i>			NPD (Nessuna Prestazione Determinata/No Performance Determined)			
Potenza termica nominale / <i>Nominal heat output</i>			12.1 kW			
Potenza termica resa in ambiente / <i>Room heating output</i>			12.1 kW			
Potenza termica ceduta all'acqua / <i>Water heating output</i>			-- kW			
Rendimento / <i>Efficiency</i>			86,7% alla potenza termica nominale / <i>Nominal heat output</i>			
9	La prestazione del prodotto di cui ai punti 1 e 2 è conforme alla prestazione dichiarata di cui al punto 8. Si rilascia la presente dichiarazione di prestazione sotto la responsabilità esclusiva del fabbricante di cui al punto 4. <i>The performance of the product identified in points 1 and 2 is in conformity with the declared performance in point 8. This declaration of performance is issued under the sole responsibility of the manufacturer identified in point 4.</i> Arsiero, 31/01/2022				Firma / <i>Signature:</i> 	

IT – SCHEDA PRODOTTO (UE 2015/1186) EN – PRODUCT FICHE (EU 2015/1186) FR – FICHE PRODUIT (UE 2015/1186) NL – PRODUCTGEGEVENSBLAD (EU 2015/1186) DE – PRODUKTDATENBLATT (EU 2015/1186) ES – FICHA DE PRODUCTO (UE 2015/1186)	IT – MARCHIO EN – BRAND FR – MARQUE NL – MERK DE – MARKE ES – MARCA	THERMOROSSI S.P.A.	
IT – MODELLO EN – MODEL FR – MODÈLE NL – MODEL DE – MODELL ES – MODELO		KLARETTA EVO KLARISSA EVO VIOLETTA EVO MELISSA EVO	KLARA EVO VIOLA EVO MARGOT EVO MARGHERITA EVO
IT – CLASSE DI EFFICIENZA ENERGETICA EN – ENERGY EFFICIENCY CLASS FR – CLASSE D'EFFICACITÉ ÉNERGÉTIQUE NL – ENERGIE EFFICIENTIEKLASSE DE – ENERGIEEFFIZIENZKLASSE ES – CLASE DE EFICIENCIA ENERGÉTICA		A +	A +
IT – POTENZA TERMICA DIRETTA EN – DIRECT HEAT OUTPUT FR – PUISSANCE THERMIQUE DIRECTE NL – DIREKTE WARMTEAFGIFTE DE – DIREKTE WÄRMELEISTUNG ES – POTENCIA CALORÍFICA DIRECTA		8.2 kW	12.1 kW
IT – POTENZA TERMICA INDIRETTA EN – INDIRECT HEAT OUTPUT FR – PUISSANCE THERMIQUE INDIRECTE NL – INDIRECTE WARMTEAFGIFTE DE – INDIRECTE WÄRMELEISTUNG ES – POTENCIA CALORÍFICA INDIRECTA		-	-
IT – INDICE DI EFFICIENZA ENERGETICA EN – ENERGY EFFICIENCY INDEX FR – INDICE D'EFFICACITÉ ÉNERGÉTIQUE NL – ENERGIE-EFFICIENTIE-INDEX DE – ENERGIEEFFIZIENZINDEX ES – INDICE DE EFICIENCIA ENERGÉTICA		117	116
IT – EFFICIENZA UTILE ALLA POTENZA TERMICA NOMINALE EN – USEFUL ENERGY EFFICIENCY AT NOMINAL HEAT OUTPUT FR – RENDEMENT UTILE À LA PUISSANCE THERMIQUE NOMINALE NL – NUTTIG RENDEMENT BIJ NOMINAAL VERMOGEN DE – BRENNSTOFF-ENERGIEEFFIZIENZ BEI NENNWÄRMELEISTUNG ES – EFICIENCIA ENERGÉTICA ÚTIL A POTENCIA CALORÍFICA NOMINAL		87.4%	86.7%
IT – EFFICIENZA UTILE AL CARICO MINIMO EN – USEFUL ENERGY EFFICIENCY AT MINIMUM LOAD FR – RENDEMENT UTILE À LA CHARGE MINIMALE NL – NUTTIG RENDEMENT BIJ MINIMALE WARMTEAFGIFTE DE – BRENNSTOFF-ENERGIEEFFIZIENZ BEI MINDESTLAST ES – EFICIENCIA ENERGÉTICA ÚTIL A CARGA MINIMA		-	-
IT – RISPETTARE TUTTE LE ISTRUZIONI RIPORTATE SUL MANUALE DI INSTALLAZIONE USO E MANUTENZIONE EN – ALWAYS FOLLOW THE INSTRUCTIONS PROVIDED IN THE OPERATING AND MAINTENANCE MANUAL FR – RESPECTER TOUTES LES INSTRUCTIONS CITÉES DANS LA NOTICE D'INSTALLATION, UTILISATION ET ENTRETIEN NL – VOLG ALTIJD DE INSTRUCTIES VAN DE INSTALLATIE-, GERUIKERSHANDLEIDING EN DE ONDERHOUDSVOORSCHRIFTEN DE – ERFÜLLEN DIE ANWEISUNGEN DER INSTALLATION, NUTZUNG UND WARTUNG, DIE IN DER ANLEITUNGSBUCH SIND ES – RESPECTAR LAS INSTRUCCIONES REPORTADAS EN EL MANUAL DE UTILIZACIÓN Y MANTENIMIENTO			

1 – INTRODUCTION

1.1 SAFETY GUIDELINES

This installation, use and maintenance manual is an integral and essential part of the product and must be kept by the user. Before commencing with the installation, use and maintenance of the product, carefully read this guide. All local, national and European regulations regarding the installation and use of the appliance must be met. The Manufacturer recommends carrying out all the maintenance operations described in this manual.

This appliance must only be used as intended by the manufacturer. Any other use is considered incorrect and therefore hazardous; consequently, the user shall be totally liable for the product if used improperly. Installation, maintenance and repairs must be carried out by professionally qualified personnel, certified according to Decree no. 37 of 22 January 2008 and in compliance with current regulations. In case of repairs only original spare parts supplied by the manufacturer must be used. Incorrect installation or poor maintenance can injure or damage people, animals or things; in this case the manufacturer shall be relieved of all responsibility. Any repairs or actions carried out on any systems, components or internal parts of the appliance, or on any of the accessories supplied with it, that are not specifically authorised by Thermorossi S.p.A, will automatically void the warranty and the manufacturer's responsibility, pursuant to Italian Decree no. 224 of the President of the Republic of 24/05/1988, art. 6/b. It is recommended to keep this manual in a safe place that is easily accessible to all users. If the manual is lost or deteriorated contact the manufacturer for a replacement copy. If the appliance is sold or transferred to another user ensure that the manual is handed over with it. The images and figures featured in this manual are purely illustrative and may differ from the actual product. Furthermore, Thermorossi reserves the right to apply changes to the content of this manual anytime and without notice.

Thermorossi S.p.A. retains copyright on this manual. These instructions may not be reproduced or communicated to third parties or used in any other way without the necessary authorisation.

1.2 SAFETY STANDARDS



PERSONAL INJURY

This safety symbol identifies important messages throughout the manual. Read the information marked by this symbol carefully as non-observance of this message can cause serious injury to persons using the appliance.



DAMAGE TO PROPERTY

This safety symbol identifies messages or instructions that are fundamental for the appliance and system to function well. To avoid serious damage to the appliance, adhere strictly to these instructions.



INFORMATION

This symbol indicates important instructions for good functioning of the appliance. If this information is not correctly observed, the performance of the appliance will not be satisfactory.

1.3 RECOMMENDATIONS



Read this entire use and maintenance manual carefully before using the appliance as familiarity with the information and instructions contained in it are essential for the correct use of the appliance.

No responsibility will be accepted for damages, even to third parties, if the instructions for installation, use and maintenance of the appliance are not followed scrupulously. Modifications made to the appliance by the user or on his behalf, must be considered to be under his complete responsibility. The user is responsible for all the operations required for the maintenance of the appliance before and during its use.



Should you notice an excessive stagnation of flue gas in the combustion chamber, move away from the appliance immediately. In particular move away from the glass door of the combustion chamber. The excessive concentration of unburned gases could create an explosion that could break the glass. Do not open the loading door for any reason whatsoever and do not approach the product until the flame has died down. Contact a technical service centre to determine the causes. Do not turn on the appliance for any reason whatsoever following an event such as this.

1.4 GENERAL GUIDELINES

The product must not be used by children under the age of 8 years, by persons with physical, mental or sensorial impairments, or by persons who are not familiar with the instructions for use and maintenance of the product (the instructions are found in this manual). Children must not play with the appliance.

ATTENTION: before lighting check that the grate of the combustion chamber is clean and that the ash pan is clean. ATTENTION: it is strictly forbidden to open the door while the flame is still burning. During operation, the smoke exhaust pipes, door, handles and some parts of the appliance may reach extremely high temperatures: be careful not to touch them and also educate children to be aware of said risks. Do not expose your body to hot air for long, do not overheat the room in which the appliance is installed, as these actions could cause health problems. Do not expose plants or animals directly to the hot air flow as this could have noxious effects on them. Do not place non-heat resistant or inflammable or combustible objects in the vicinity of the appliance: keep them at a suitable distance. Do not place wet clothing to dry on the appliance. When using a clothes horse, keep at a suitable distance.



Attention: do not wet the appliance. Never vacuum hot ash: this could damage the vacuum device. All the cleaning operations described in this manual must be carried out when the appliance is cold.



Attention! Warning for Swiss users

Refer to the local cantonal regulations imposed by the Fire Department (Mandatory signalling and safety distances) and the Note concerning installation of heaters issued by the Association of Cantonal Fire Agencies (VKF - AEAI).

1.5 TRANSPORTATION AND STORAGE

TRANSPORTATION AND HANDLING

The appliance body must always be handled exclusively by means of trolleys. Take special care to protect the glass and all the fragile parts from mechanical impact which could damage them and their correct functioning.

STORAGE

The appliance must be stored in a humid-free environment and sheltered from the weather; avoid placing the appliance directly on the ground. The Company denies all responsibility for damage caused to wood floors or floors made from any other material. It is inadvisable to store the product for long periods of time.

1.6 GUIDELINES FOR CORRECT DISPOSAL OF THE PRODUCT



At the end of the product's useful life, it must be disposed of in compliance with applicable regulations and in respect of the environment, not with urban waste. The product must be consigned to designated sorted waste collection centres for the disposal of waste authorised by the local municipal councils. Correct disposal not only helps safeguard the environment but it also promotes recovery and recycling of the materials.

2 – TECHNICAL CHARACTERISTICS

	KLARETTA EVO	VIOLETTA EVO	KLARISSA EVO	MELISSA EVO
Height (mm)	863	863	863	863
Depth (mm)	576	576	578	578
Width (mm) without handrail	770	770	770	770
Weight (Kg)	166	175	169	177
Smoke outlet diameter (mm)	130	130	130	130
Minimum draft (Pa)	12	12	12	12
Maximum permitted fuel feed Kg ***	1,7	1,7	1,7	1,7
Maximum hourly consumption (Kg/h) ***	2,2	2,2	2,2	2,2
Average load duration (Min) **	45	45	45	45
Firebox power (kW) **	9,4	9,4	9,4	9,4
Rated power (kW) **	8,2	8,2	8,2	8,2
Efficiency (%) **	87,4	87,4	87,4	87,4
CO emissions (mg/m ³ at 13% O ₂) **	324	324	324	324
Heatable volume (m ³) *	220	220	220	220
Average smoke temperature (°C) **	203	203	203	203
Smoke flow rate (g/s) **	5,5	5,5	5,5	5,5
Firebox feed opening dimensions (mm) (LxH)	214x273	214x273	214x273	214x273
Firebox dimensions (mm) (LxHxD)	235x364x382	235x364x382	235x364x382	235x364x382
Top oven dimensions (mm) (LxHxD)	253x307x336	253x307x336	253x100x336	253x100x336
Bottom oven dimensions (mm) (LxHxD)			253x252x336	253x252x336

	KLARA EVO	VIOLA EVO	MARGOT EVO	MARGHERITA EVO
Height (mm)	863	863	863	863
Depth (mm)	676	678	676	678
Width (mm) without handrail	910	910	910	910
Weight (Kg)	203	215	210	222
Smoke outlet diameter (mm)	130	130	130	130
Minimum draft (Pa)	12	12	12	12
Maximum permitted fuel feed Kg ***	2,4	2,4	2,4	2,4
Maximum hourly consumption (Kg/h) ***	3,25	3,25	3,25	3,25
Average load duration (Min) **	45	45	45	45
Firebox power (kW) **	13,9	13,9	13,9	13,9
Rated power (kW) **	12,1	12,1	12,1	12,1
Efficiency (%) **	86,7	86,7	86,7	86,7
CO emissions (mg/m ³ at 13% O ₂) **	387	387	387	387
Heatable volume (m ³) *	330	330	330	330
Average smoke temperature (°C) **	224	224	224	224
Smoke flow rate (g/s) **	7,6	7,6	7,6	7,6
Firebox feed opening dimensions (mm) (LxH)	284x273	284x273	284x273	284x273
Firebox dimensions (mm) (LxHxD)	305x364x482	305x364x482	305x364x482	305x364x482
Top oven dimensions (mm) (LxHxD)	323x307x436	323x307x436	323x100x436	323x100x436
Bottom oven dimensions (mm) (LxHxD)			323x252x436	323x252x436

* **IMPORTANT:** it is important to take into consideration the fact that the heatable volume is greatly influenced by the insulation of the house (energy class of the building) and by the position of the appliance in the planimetry of the house, therefore the indicated values may vary, even significantly.

** **ATTENTION:** the indicated values were obtained using beechwood logs (2 logs) with thermal value less than 15,429 kJ/kg and moisture content less than 15%. The use of poorer quality firewood than that specified results in lower yield and lower efficiency, and produces more ash. Moreover the glass on the feed door will become dirtier sooner.

*** It is strictly prohibited to load a greater quantity of fuel than that specified in the table. The warranty will not cover damages caused by the prolonged exposure of the appliance to temperatures that are too high.

2.1 DIMENSIONS

KLARETTA EVO – VIOLETTA EVO

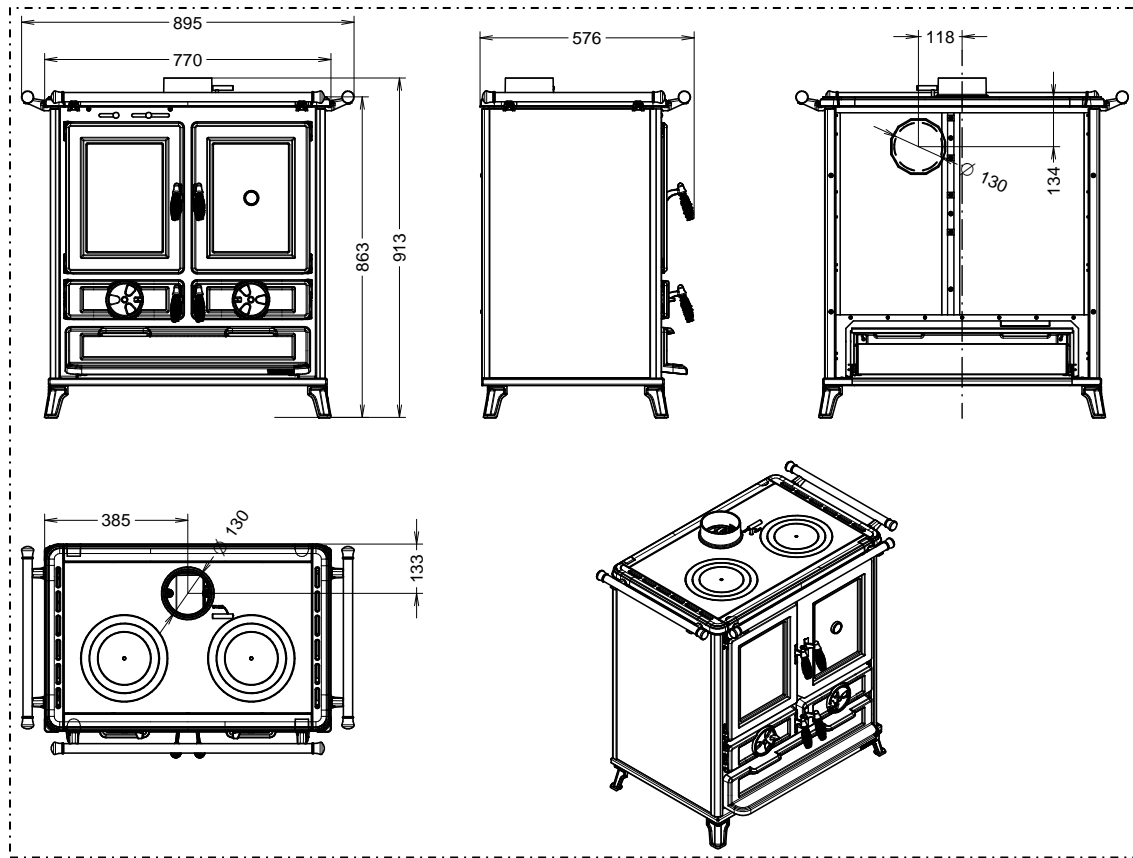

KLARISSA EVO – MELISSA EVO

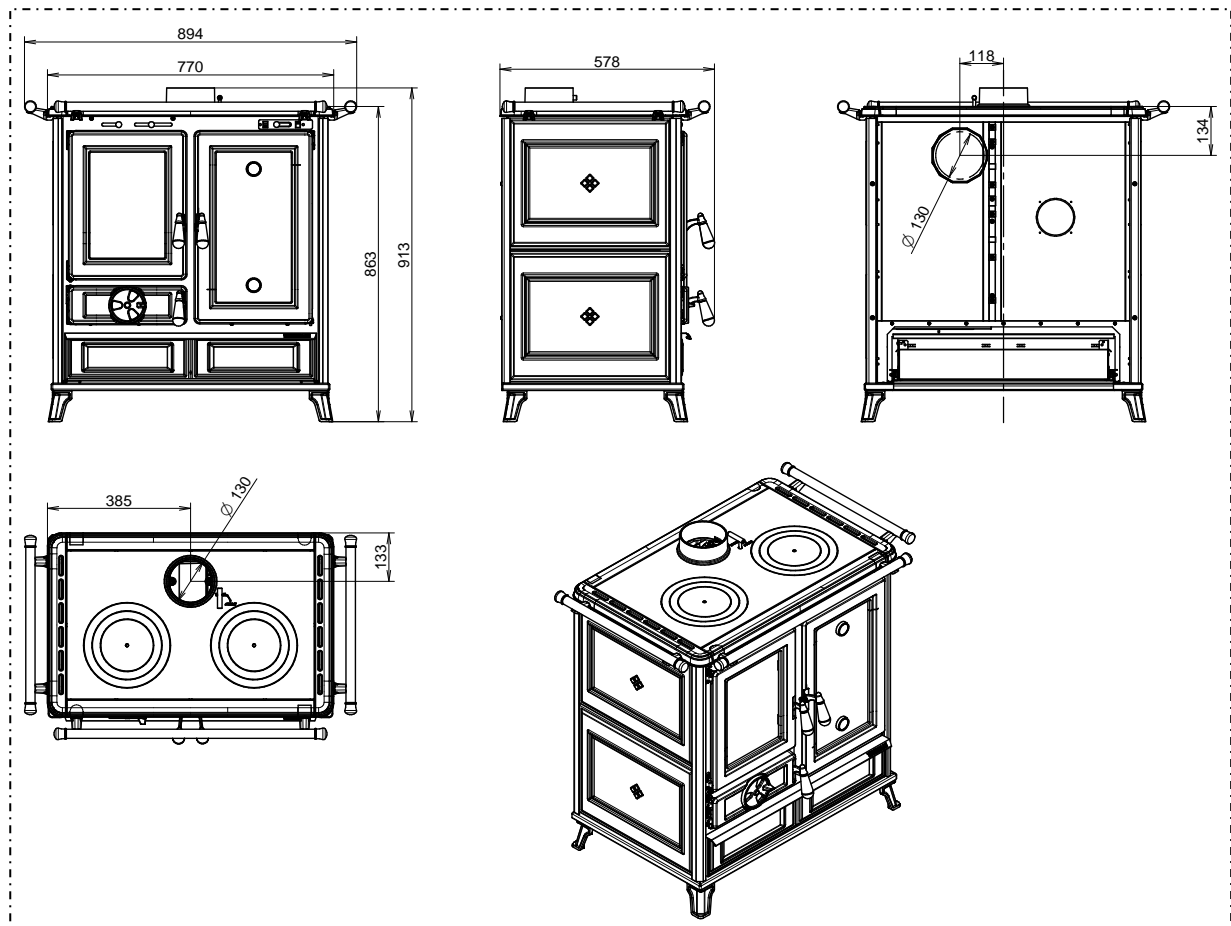

KLARA EVO – VIOLA EVO

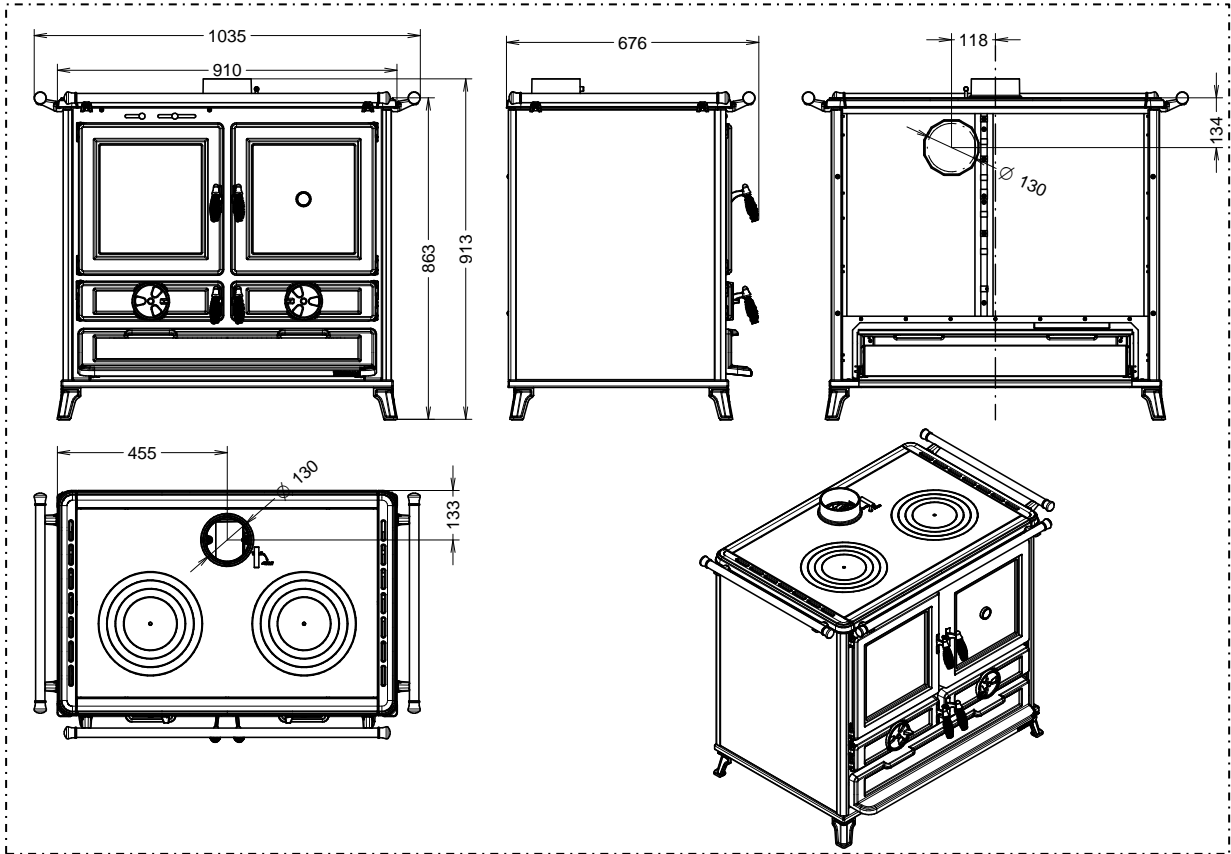

MARGOT EVO – MARGHERITA EVO

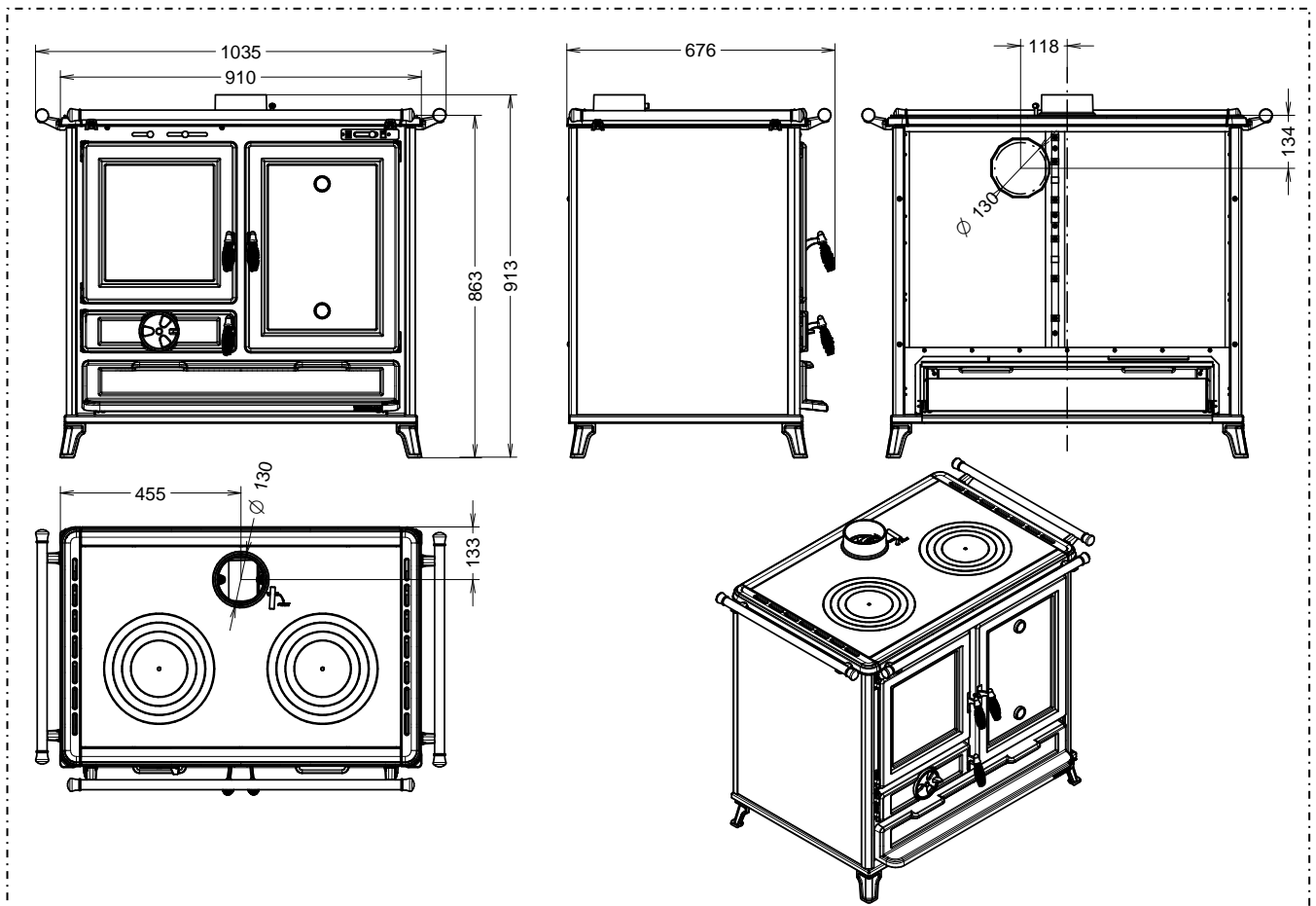

3 – GENERAL DESCRIPTION

3.1 THE FUEL

The fuel for this appliance is ordinary wood billets with a moisture content between 10% and 20% and with a thermal value of 10,400 to 16,400 kJ/kg. We recommend using beech or common hornbeam. If using wood with a lower moisture content or with a higher thermal value the heat produced by the stove will be greater.

The awareness and use of the right fuel are important aspects to be observed in order to ensure correct operation and long service life of the appliance. To this end we recommend using only dry, well-seasoned wood. We recommend against using wet wood or wood that has been seasoned for less than 18/20 months, as this could be the cause of malfunctions and the formation of tarry deposits that could permanently blacken the walls of the combustion chamber.

We recommend using logs of max 330 mm long (max recommended section Ø 80 mm) and loading a maximum of 2-3 logs.



MAXIMUM PERMITTED FUEL FEED:

- 1.7 kg KLARETTA EVO, VIOLETTA EVO, KLARISSA EVO and MELISSA EVO.
- 2.4 Kg KLARA EVO, VIOLA EVO, MARGOT EVO and MARGHERITA EVO.

THE FUEL FEED INTERVALS MUST NOT BE LESS THAN 1 HR.



LOADING A LARGER QUANTITY OF FUEL OR LOADING SEVERAL TIMES IN AN HOUR EXPOSES THE COMPONENTS OF THE APPLIANCE TO VERY HIGH TEMPERATURES. FOR THIS REASON, THE WARRANTY WILL NOT COVER ANY DAMAGE CAUSED BY PROLONGED EXPOSURE OF THE APPLIANCE TO THESE TEMPERATURES.



The use of fuel that does not comply with the above specifications or the use of different substances or fuels will immediately void the appliance warranty. The appliance must not be used as an incinerator, and it is prohibited to use any liquid or gas fuel. Do not overload the stove with excessive quantities of fuel; adhere strictly to the maximum declared consumption.



It is strictly prohibited to use the under-oven compartment or the tool storage compartment for storing combustible or flammable material. The temperature inside can reach very high levels.

3.2 MAIN COMPONENTS

KLARETTA EVO – VIOLETTA EVO – KLARA EVO – VIOLA EVO

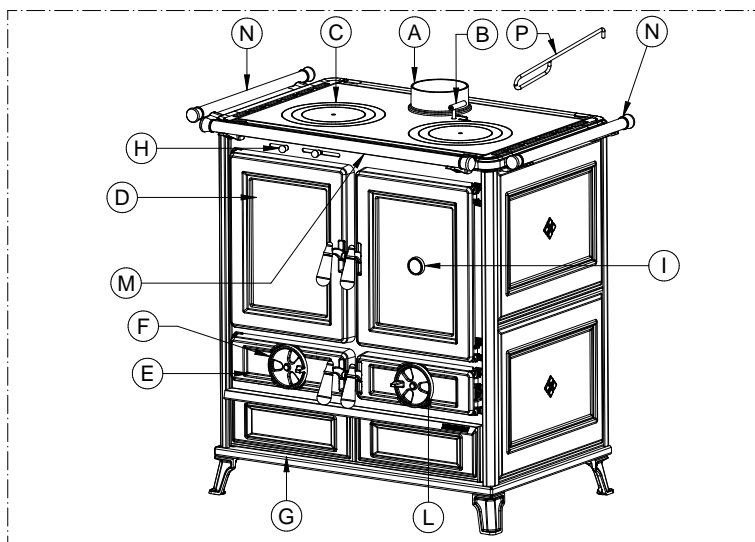

KEY

A	Top smoke exhaust	B	Starter
C	Cooktop	D	Door firebox
E	Ash pan and riddling lever	F	Primary air control
G	Tool storage compartment	H	Secondary air levers
I	Oven	L	Under-oven compartment
M	Front handrail	N	Side handrail (optional)
P	Riddling tool		

KLARISSA EVO – MELISSA EVO – MARGOT EVO – MARGHERITA EVO

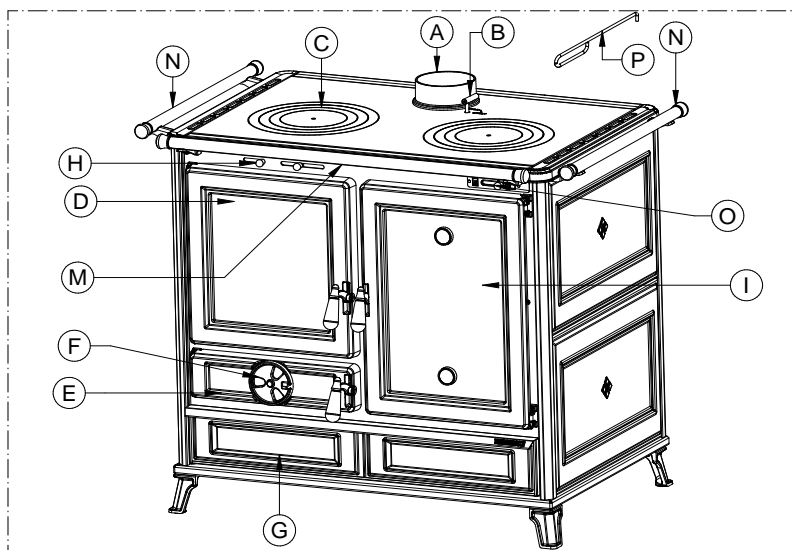

KEY

A	Top smoke exhaust	B	Starter
C	Cooktop	D	Door firebox
E	Ash pan and riddling lever	F	Primary air control
G	Tool storage compartment	H	Secondary air levers
I	Oven	M	Front handrail
N	Side handrail (optional)	O	Device PANEPICCA®
P	Riddling tool		

F – Primary air control

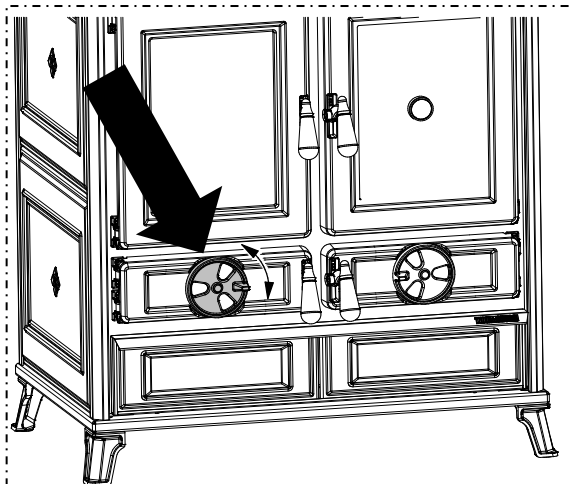

It is used to regulate the primary air inflow. The primary air passes through the grate of the firebox and fuels the combustion to determine its power and speed. Rotate the control counterclockwise to reduce the air flow. On the contrary, rotate the control clockwise to increase the air flow.



ATTENTION: when the appliance is operating the temperature of the primary air control is very high, so take care not to touch it. The glove provided must be worn when handling it.

H – Secondary air lever

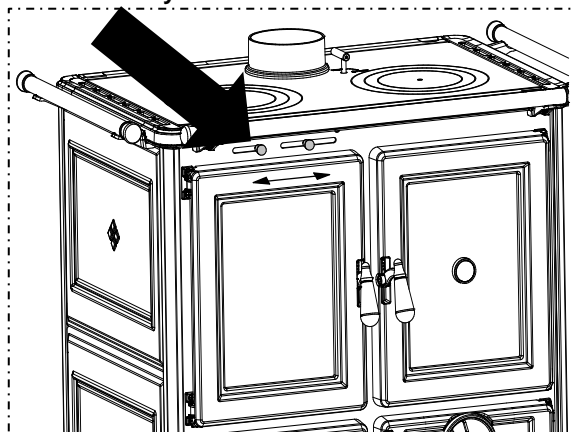

It is used to regulate the secondary air inflow. As the secondary air passes through the holes in the back wall of the combustion chamber, it preheats and contributes to the second combustion as well as having the function of keeping the glass clean. Shift one of the two levers to the left to reduce the air flow. Whereas to increase the inflow air shift it to the right.



ATTENTION: the temperature of the secondary air levers is very hot while the appliance is operating, so take care not to touch them. The glove provided must be worn when handling them.

B – Starter

This device creates a direct bypass for the flue gases which facilitates both the lighting and refuelling operations. The glove provided must be worn when activating it and only when lighting or stoking the fire.



IT IS STRICTLY PROHIBITED TO LEAVE THE STARTER OPEN DURING NORMAL OPERATION.

Leaving the starter open during normal operation results in higher fuel consumption than the declared quantity, a considerable drop in efficiency and exposure of the appliance to extremely high temperatures. For this reason, the warranty does not cover any direct or indirect damages caused by prolonged exposure of the appliance to these temperatures. **ATTENTION: the temperature of the starter is very hot while the appliance is operating, so take care not to touch it. The glove provided must be worn when handling it.**

Turning the starter towards the word START activates the direct bypass for the flue gases, whereas turning it towards the word WORK activates the normal flue gas path.

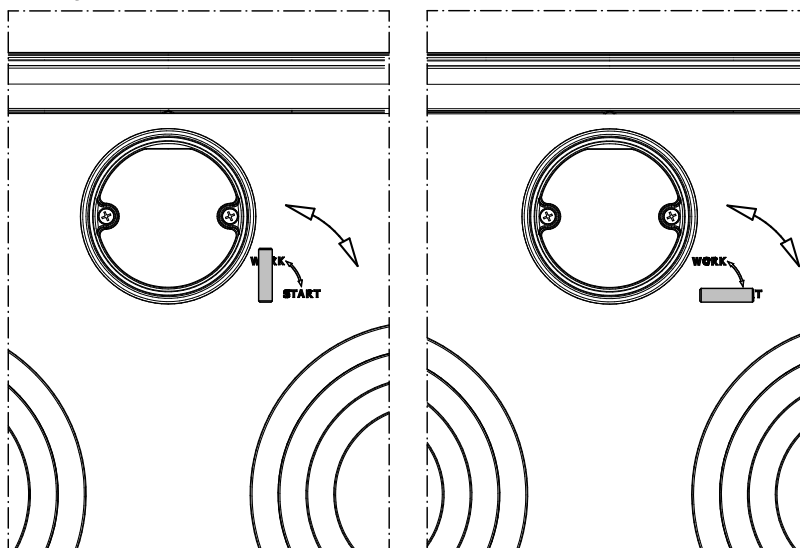

4 – INSTALLATION

4.1 APPLIANCE LOCATION



Follow the general guidelines set out in paragraph 1.1 to the letter. Be aware that the flooring of the installation site must be capable of withstanding the weight of the appliance. If this requirement is not met, it is obligatory to adopt counter measures (for example, load distribution plate ...).



ATTENTION: the room where the appliance is installed must be well-ventilated and free from humidity and salty air. A high level of humidity or saltiness in the room can lead to the onset of rust or corrosion which will not be covered by warranty. The appliance must be positioned at a minimum safe distance from walls and furnishings. If inflammable materials are located in the vicinity of the appliance (e.g.: matchboarding, furniture, curtains, pictures and paintings, sofas) it is mandatory to comply with the minimum distances illustrated on the side.



If the flooring is made of wood or any other combustible material, it is mandatory to install a fireproof floor protector plate between the appliance and the floor. Installation in the vicinity of heat-sensitive materials is only permitted if suitable insulating and fireproof protection is placed between the object and the appliance (ref. Uni 10683). Failure to observe this instruction will immediately invalidate the warranty.

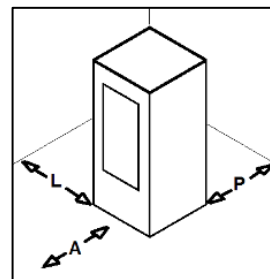

A = 800 mm
L = 300 mm
P = 300 mm

The installer must issue a certificate of conformity for the installation which includes the design plans and the following documents:

- a) Report containing the type of materials utilised.
- b) Project as defined in Article 5 of Ministerial Decree n° 37 22 January 2008.
- d) References to existing partial or previous declarations of conformity (e.g., flue outlet).
- e) Copy of the certificate of recognition of the professional technical qualifications.



These documents must, by law, be kept together with the installation, use and maintenance manual. The customer is responsible for verifying, directly or indirectly, that the installation has been carried out to perfection in accordance with relevant regulations in force. Do not install the appliance in unsuitable rooms such as bedrooms, bathrooms, garages and/or lock-ups. It is forbidden to place the appliance in environments with an explosive atmosphere.



ATTENTION, the appliance is not simply a household appliance: if the instructions set out in this manual are not followed and/or if installation of the appliance is not executed perfectly and/or the provisions in force are not strictly complied with, dangerous conditions could arise for both objects and persons. It is the user's responsibility to verify the presence, in the room, of a vent necessary for supplying oxygen to the appliance. It is strictly prohibited to install the appliance as inset or next to furniture.

4.2 UNPACKING THE APPLIANCE

The appliance is supplied packaged on a pallet; always use trolleys to move the appliance and the appliance must always be in a vertical position. Before positioning and installing it dismantle the appliance from the pallet as described:

- Remove the cover and side panels from the pallet.
- Remove the feet fasteners.
- Remove the appliance from the pallet with the aid of a trolley. Slip the bottom of the trolley under the back part of the appliance and tip the trolley back onto its wheels. Given the weight of the appliance we recommend that this operation be carried out by two people. Take care when lifting the appliance as the centre of gravity of the weight is concentrated at the front.
- Check that all the mobile parts are in place; remove the labels and stickers from the glass.

REMOVE PROTECTIVE FILM FROM THE COOKTOP.

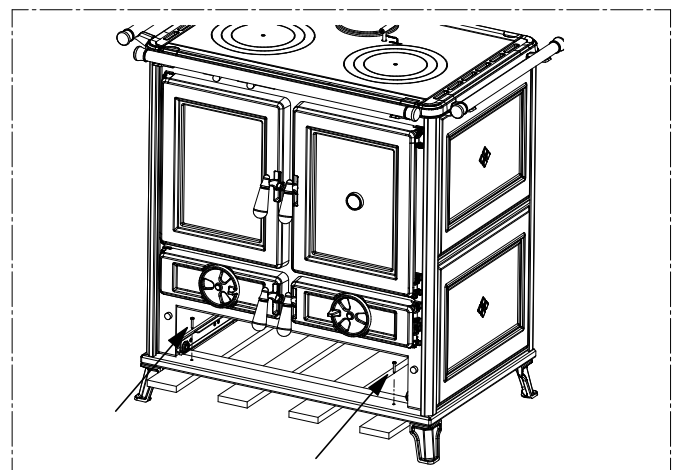
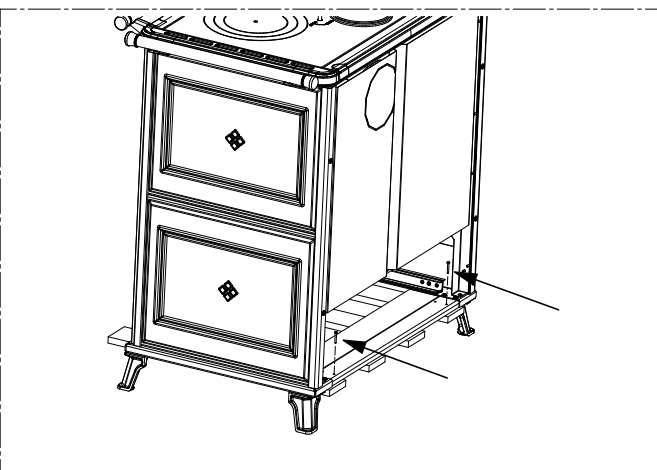
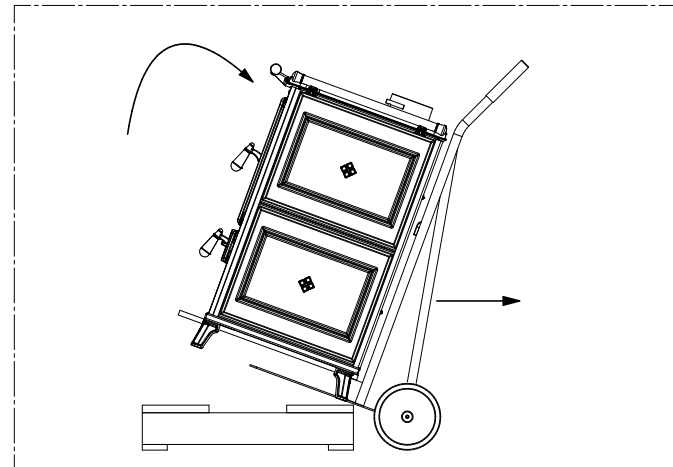
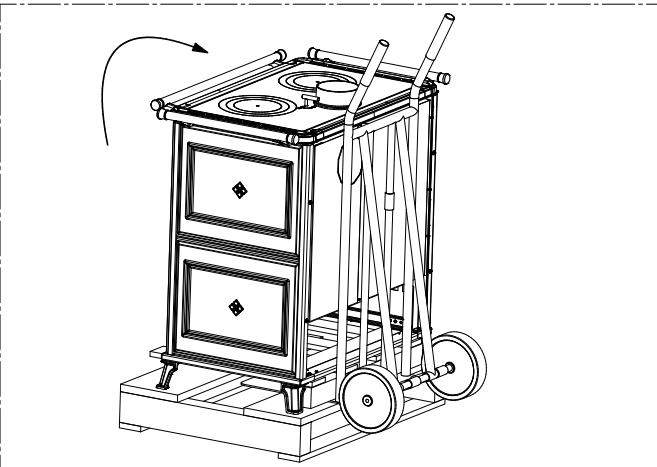
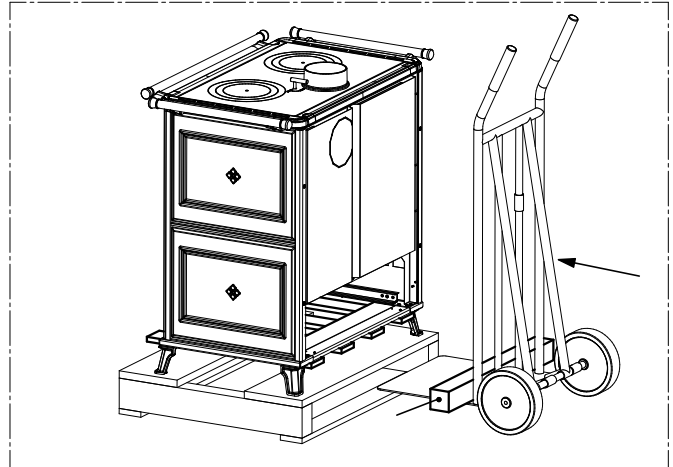
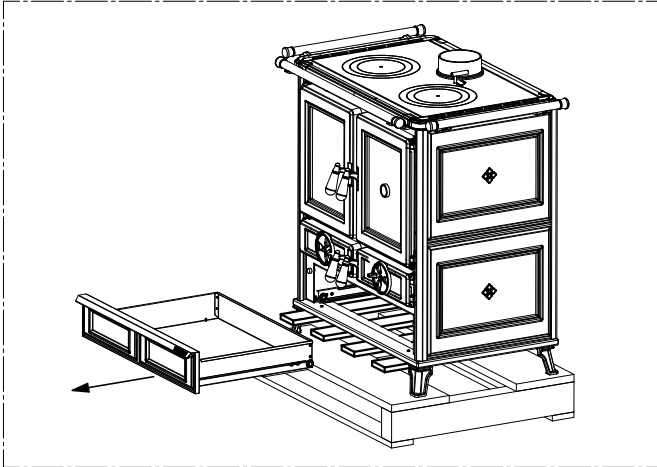

IMPORTANT: HANDLE THE APPLIANCE WITH CARE, AS DAMAGE CAUSED DURING THE UNPACKING OPERATION WILL NOT BE COVERED BY THE WARRANTY.

5 – ASSEMBLING THE COMPONENTS

5.1 MOUNTING THE FRONT HANDRAIL

To mount the front handrail proceed as follows:

- 1) Fix the two supports (AO) to the handrail (AN) using the 2 screws (AK), see Figure 1.
- 2) Insert the handrail complete with supports under the cooktop frame as shown in Figure 2.
- 3) Tighten the 2 nuts (AP) onto screws (AQ) as shown in Figure 3.
- 4) Insert the screws with nuts (AQ) into the handrail complete with supports and tighten until the handrail is firmly secured to the appliance. See Figure 4.

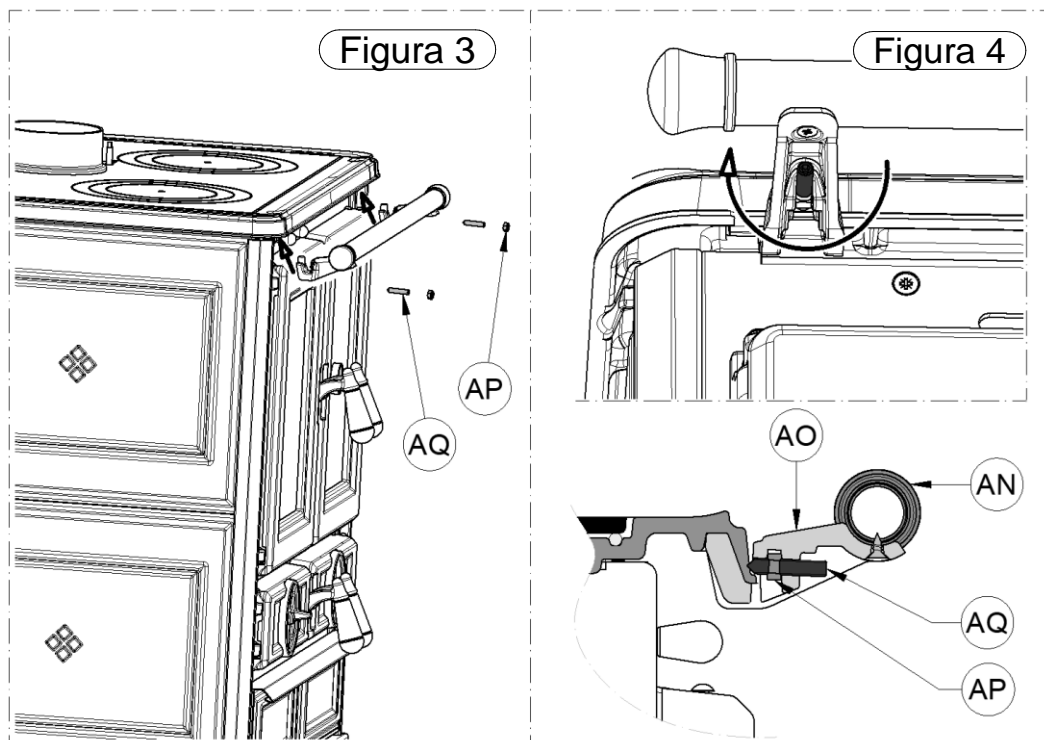
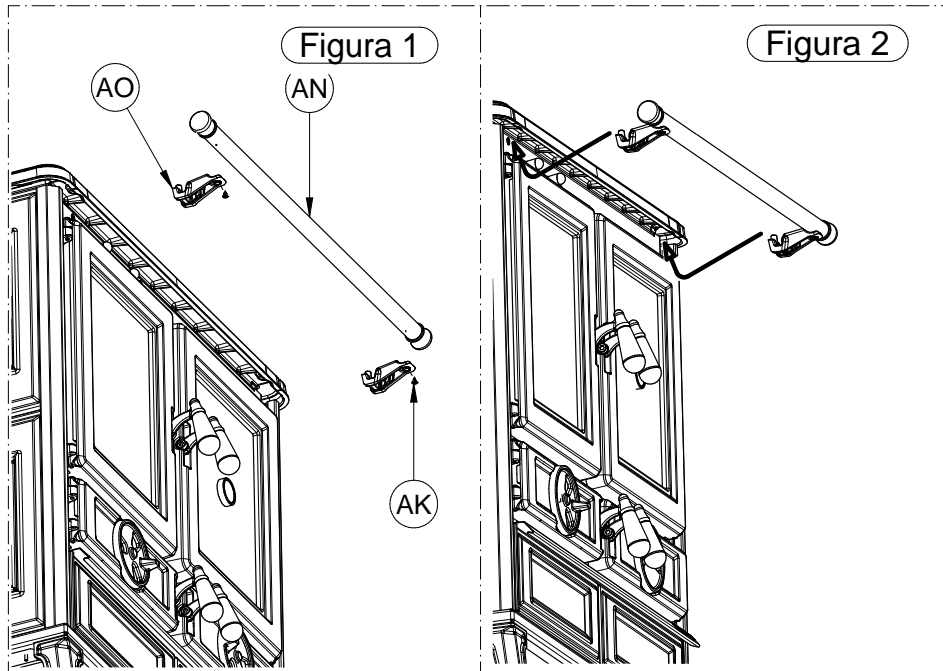

5.2 MOUNTING THE SIDE RAIL (OPTIONAL)

To mount the side handrail, follow the same procedures described in the paragraph: 5.1 MOUNTING THE FRONT HANDRAIL.

5.3 MOUNTING THE SMOKE OUTLET COLLAR

A smoke outlet collar is supplied with the product. The smoke outlet collar can be fixed to the back of the appliance for a rear smoke outlet, otherwise it can be fixed to the top of the appliance for a vertical smoke outlet.

REAR SMOKE OUTLET:

If opting for the rear smoke outlet then you must remove the pre-cut flange indicated in the figure on the side. Remove the cover (AG) by undoing the screws (AE) and fix the collar (AD) with the screws (AE). Then close the top smoke outlet with the cover (AG) removed from the back and secure with the screws (AE). There must be no narrowing of the pipes that connect the appliance to the flue outlet. The joints must be completely airtight.

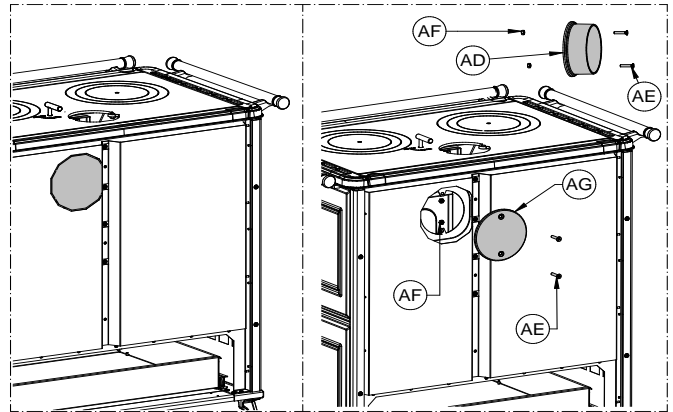

TOP SMOKE OUTLET:

If opting for the top smoke outlet fix the collar (AD) with the screws (AE). There must be no narrowing of the pipes that connect the appliance to the flue outlet. The joints must be completely airtight.

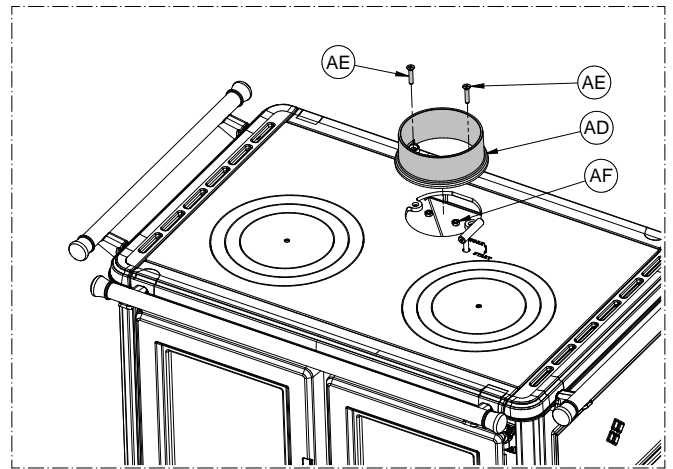

5.4 CASINGS

The appliance is supplied with pre-mounted casings.

For majolica casings:



ATTENTION: the majolica tiles are handcrafted so they could contain subtle surface imperfections, crazing or shade variations. The layer of glaze has an expansion factor that is different to that of the majolica tiles which is what causes the hairline cracks. This phenomenon is a natural process and is not a defect. We recommend cleaning the majolica tiles with a dry microfibre cloth. Using moist or wet cleaning cloths would show up the natural crazing even more; use only dry, non-abrasive cloths and when the appliance is cold.

For metal and cast iron casings:



ATTENTION: we recommend cleaning the metal and cast iron only with a dry or slightly moist microfibre cloth. Use only non-abrasive cloths on a cold appliance.

6 – USE OF THE APPLIANCE



The appliance, when operating, is hot to the touch, particularly the door of the combustion chamber: consequently, take care not to touch any surface. Your appliance has obtained the CE marking. The product must not be used by children, by persons with physical or mental impairments, by persons who are not familiar with the instructions for use and maintenance of the product (the instructions are found in this installation, use and maintenance manual). During the heating and cooling stages, the appliance is exposed to considerable thermal expansions that can cause light expansion sounds. This is a normal process and is not a defect of the product.



ATTENTION: the door must always remain shut tight when the appliance is operating. While the appliance is in operation the smoke exhaust pipes can reach extremely high temperatures: do not touch them! It is strictly forbidden to use any type of liquid or gaseous fuel to light the appliance. Do not place non-heat resistant or inflammable or combustible objects in the vicinity of the appliance: keep them at a suitable distance. Do not place wet clothing to dry on the appliance. When using a clothes horse, keep at a suitable distance. During the first lighting the paint on the product and the protective oil on the cooktop may give off a slight smell as they complete their drying. This is quite normal. It is recommended to ventilate the room until the paint has completely dried.

6.1 LIGHTING

To startup the stove proceed as follows:

- 1) Turn the starter towards the word Start (see paragraph 3.2).
- 2) Rotate the primary air control clockwise as far as it will go (see Figure 1).
- 3) Move the secondary air levers all the way to the right (see Figure 1).



ATTENTION: BEFORE LIGHTING THE APPLIANCE MAKE SURE THAT THE GRATE IN THE FIREBOX IS CLEAN, THAT IS THAT THERE IS NO ASH OR COMBUSTION RESIDUES.

- 4) Open the firebox door, place some kindling in the firebox and light it with paper or any other tinder available on the market, then close the firebox door (figure 2).



IT IS PROHIBITED TO USE ANY LIQUIDS OR GASES SUCH AS ALCOHOL, PETROL ETC. TO LIGHT OR REKINDLE THE FIRE.

- 5) Do not leave the appliance unsupervised while the lighting process is still in progress (roughly 30 minutes to complete the process) or whenever there are abundant burning embers present.



Figura 1



Figura 2

- 6) Once the lighting sequence is completed close the starter using the supplied glove by rotating it towards the word WORK.

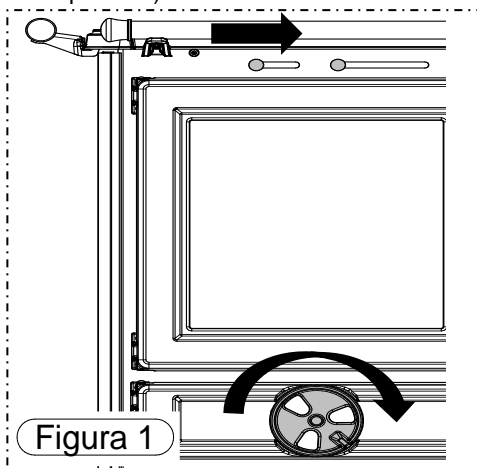

ATTENTION: THE DOOR OF THE COMBUSTION CHAMBER AND OF THE ASH PAN MUST ONLY BE OPENED FOR THE LIGHTING OPERATIONS, FOR STOKING AND FOR REMOVING RESIDUAL MATERIAL. DURING NORMAL OPERATION THE FIREBOX DOOR MUST REMAIN FIRMLY CLOSED AND THE STARTER MUST BE IN THE OFF POSITION.

Leaving the starter open during normal operation results in higher fuel consumption than the declared quantity, a considerable drop in efficiency and exposure of the appliance to extremely high temperatures. For this reason, the warranty does not cover any direct or indirect damages caused by prolonged exposure of the appliance to these temperatures. **ATTENTION: the temperature of the starter is very hot while the appliance is operating, so take care not to touch it. The glove provided must be worn when handling it.**



ATTENTION: IT IS NORMAL FOR THE COOKTOP, AFTER THE FIRST LIGHTING, TO ACQUIRE AND RETAIN A BLuish AND/OR YELLOWISH HUE.

6.2 REFUELLING

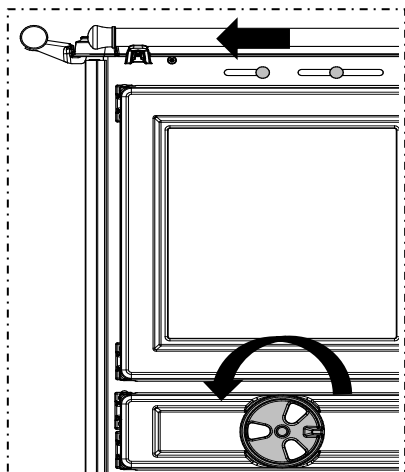

The stove is an intermittent combustion appliance so it requires refuelling. Once combustion is achieved inside the combustion chamber and consequently there are embers present, proceed with the first fuel feed:

- 1) Rotate the starter towards the word Start.
- 2) Wait a few seconds and open the firebox door slowly to minimise the risk of smoke escaping and use the riddling tool to spread the embers.

N.B. It is prohibited to light or reload the fuel with a bed of embers higher than 3 cm as this does not guarantee correct use of the appliance.

- 3) Take two logs, each of which must not exceed the weight specified in the technical data table, and lay them parallel in the centre of the grate in the combustion chamber, as illustrated in the figures below.
- 4) Slowly close the door of the firebox, close the starter using the supplied glove by rotating it towards the word WORK.
- 5) Rotate the primary air control almost all the way to the end and move the secondary air levers all the way to the left.

To rekindle the fire, clear the ash from the air passage slots to promote better combustion. Do not add additional fuel until the previous load has burnt or is reduced to embers, then open the firebox door slowly and place the logs in an orderly manner on the bed of embers. Complete the operation by slowly closing the door and return the air control and levers to the positions described above.



6.3 PANEPIZZA® DEVICE

On the KLARISSA EVO, MELISSA EVO, MARGOT EVO and MARGHERITA EVO models, when you want to bake foods that require high temperatures, such as bread or pizza, simply shift the smoke deviator flap to the right to raise the temperature in the top oven. In this case the majority of the heat generated by the appliance is directed to the top oven, and the amount of heat in the bottom oven is limited. On the other hand when you want to heat both ovens simply shift the Panepizza® device to the left.

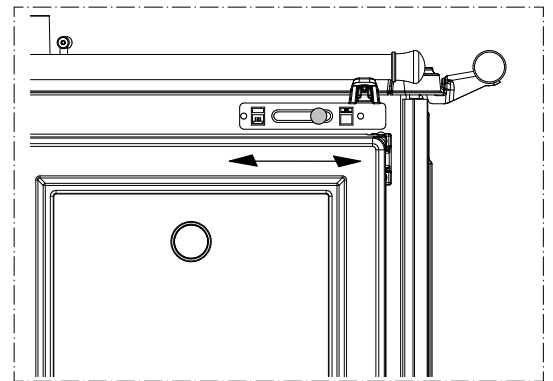

6.4 THERMOMETERS

The product comes standard with one or two thermometers on the oven glass, depending on the model chosen.



THE THERMOMETER GIVES AN APPROXIMATE, NOT PERFECTLY RELIABLE, READING OF THE OVEN TEMPERATURE. THE OVEN TEMPERATURE IS STRICTLY RELATED TO THE QUALITY OF THE FUEL, THE FLUE OUTLET DRAUGHT AND OTHER FACTORS, AND MAY EXPERIENCE SUDDEN VARIATIONS. THEREFORE ALWAYS VISUALLY CHECK THE FOOD FOR DONENESS.

6.5 PRESCRIPTIONS FOR CORRECT OPERATION

- Respect the maximum declared consumption, do not over-load the stove with excessive quantities of fuel as this could cause damage.



MAXIMUM PERMITTED FUEL FEED:

- 1.7 kg KLARETTA EVO, KLARISSA EVO, VIOLETTA EVO and MELISSA EVO.
- 2.4 kg KLARA EVO, VIOLA EVO, MARGOT EVO and MARGHERITA EVO.

THE FUEL FEED INTERVALS MUST NOT BE LESS THAN 1 HR.



LOADING A LARGER QUANTITY OF FUEL OR LOADING SEVERAL TIMES IN AN HOUR EXPOSES THE COMPONENTS OF THE APPLIANCE TO VERY HIGH TEMPERATURES. FOR THIS REASON, THE WARRANTY WILL NOT COVER ANY DAMAGE CAUSED BY PROLONGED EXPOSURE OF THE APPLIANCE TO THESE TEMPERATURES.



DO NOT THROW THE WOOD INTO THE COMBUSTION CHAMBER, PLACE IT IN GENTLY. THROWING THE WOOD COULD END UP BREAKING PARTS. DAMAGE CAUSED IN THIS WAY IS NOT COVERED BY WARRANTY.

- The appliance must not be used as an incinerator, the use of liquid or gaseous fuels is prohibited.
- Adhere strictly to the operating instructions set out in this manual.
- Always verify that the fuel loaded into the combustion chamber lights correctly. Make sure that this always occurs to avoid any buildup of combustible gases. The buildup of a high quantity of combustible gases could exceed the mechanical resistance of the glass and other components of the stove. For these reasons, the manufacturer disclaims all responsibility.
- In adverse weather conditions, such as for example low pressure, windy or rainy days or days with high outside temperatures, the effect could be a drop in draught or reverse draught. In these situations, the flue gases may not be completely exhausted. Consequently, in these cases it is necessary to increase the primary air and load the smallest amount of fuel in order to reactivate the draught of the flue outlet. If you notice the smell of smoke in the room or stagnation of gases inside the combustion chamber avoid using the appliance.

7 – CLEANING AND MAINTENANCE

7.1 FOREWORD



To guarantee correct operation and optimal performance of the appliance at all times carry out the operations described below. Observe the recommended frequency.

If the product is unused for a prolonged period of time before starting up it is mandatory to inspect the smoke channel and outlet to ensure that there are no obstructions. It is important to carefully follow the instructions set out below: failure to observe these instructions could cause serious damage to the product, to the system, to objects and to persons using the appliance.



Attention: do not wet or touch the appliance with wet hands. Never vacuum hot ash: this could damage the vacuum device. All the cleaning operations described in this manual must be carried out when the appliance is cold.

The user must periodically clean the appliance, or have an authorised service centre clean it, as described in this manual. Moreover, once a year it is advisable to have an inspection carried out of the functionality of the flue outlet.

7.2 CLEANING AND MAINTENANCE

EVERY TIME YOU REFUEL:

- Agitate the riddling lever back and forth several times so that the ash drops through the slots in the grate. If necessary, thoroughly clean the grate of the combustion chamber by de-ashing the grate through the slots. The air passage through the firebox grate must always be kept free from obstructions. Use the supplied riddling tool for this operation.

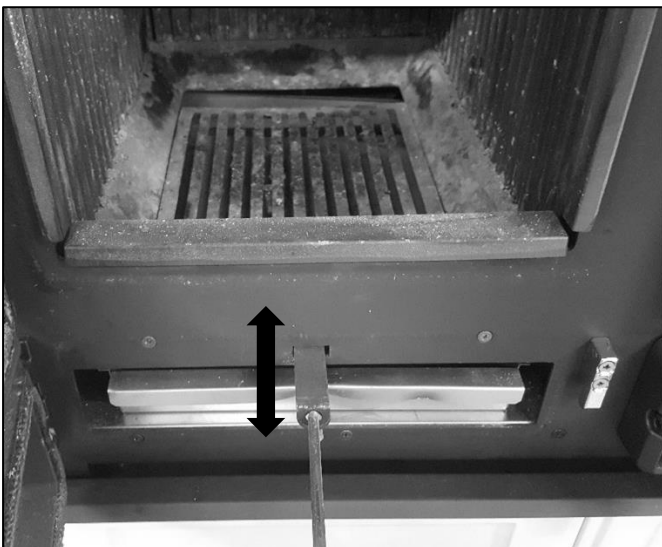

EVERY TWO DAYS or WHENEVER NECESSARY:

- Empty the ash pan. We recommend emptying the ash pan regularly before it fills up completely.



EVERY WEEK:

- Use an ash vacuum device to clean the combustion chamber.

EVERY 6 MONTHS:

- Lift and remove the cooktop to clean the flue path with a flue brush and ash vacuum device. To remove the cooktop, you must:
 - 1) Remove the Starter by pulling it upwards.
 - 2) Remove all the rings from the cooktop with the riddling tool.
 - 3) Lift the cooktop and vacuum the flue path thoroughly.

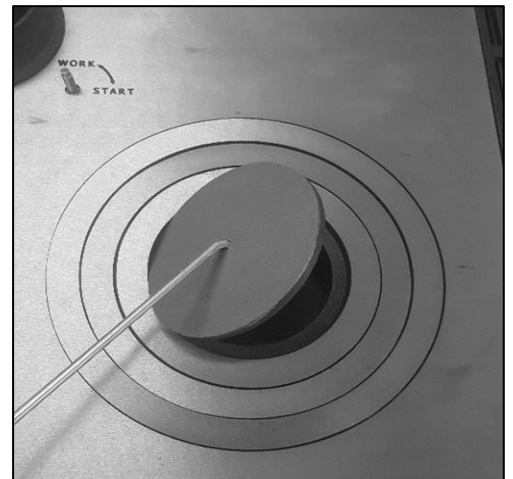
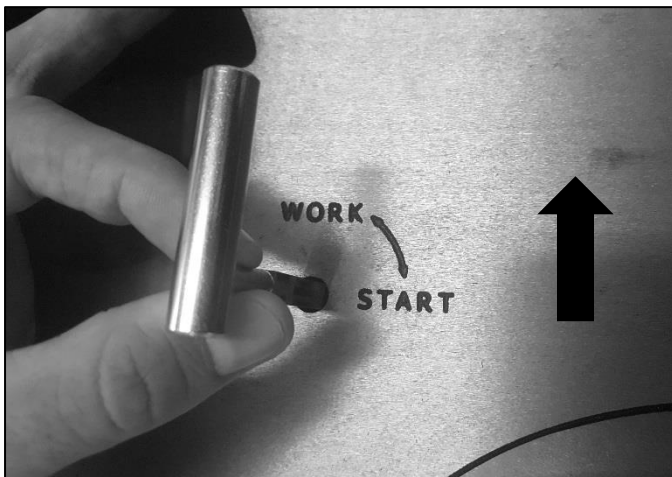

EVERY 6 MONTHS:

- Vacuum the under-oven compartment. To clean the under-oven compartment, you must:

FOR THE KLARETTA EVO, VIOLETTA EVO, KLARA EVO AND VIOLA EVO MODELS:

- 1) Undo the two screws indicated in the figure using a Phillips screwdriver.
- 2) Remove the oven bottom and clean thoroughly.

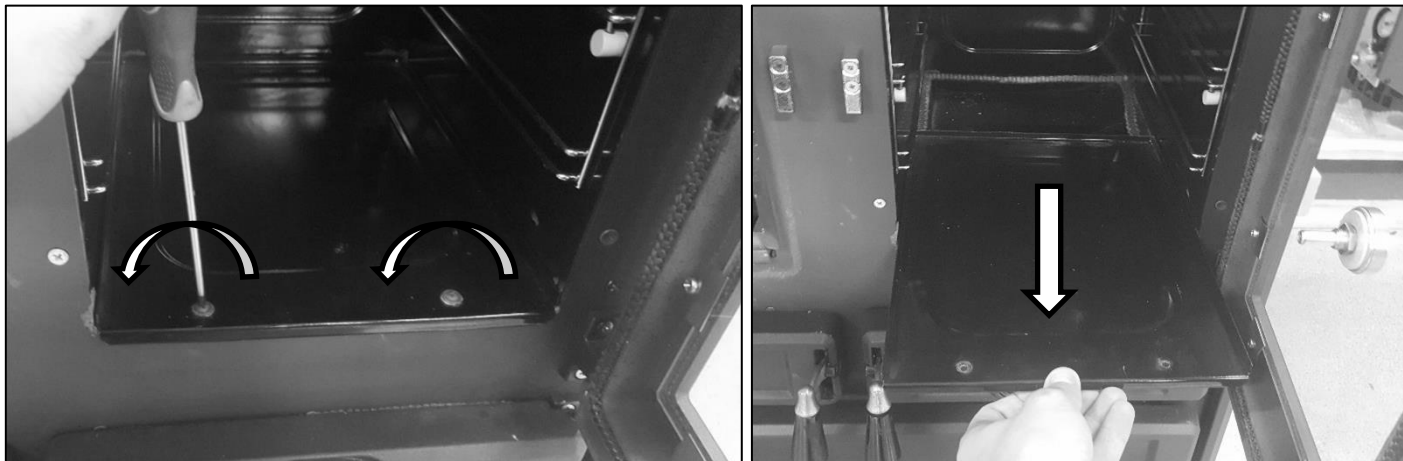

FOR THE KLARISSA EVO, MELISSA EVO, MARGOT EVO and MARGHERITA EVO MODELS:

- 1) Remove the upper soapstone shelf and clean thoroughly.
- 2) Remove the lower soapstone shelf and clean thoroughly.



AT LEAST ONCE A YEAR:

- Clean the flue outlet. If there are any horizontal sections, inspect them and clean out any ash and soot deposits before they block the passage of the flue gases.

7.3 CLEANING THE COOKTOP AND GLASS ELEMENTS

Clean the cooktop with normal, mild detergents. After cleaning protect the plate by applying a thin layer of oil to it to keep it clean and shiny. Alternatively, apply a thin layer of protective chrome paste readily available at hardware stores. Take care when applying the oil to avoid indelibly soiling the side edges. If any rust appears remove with a slightly abrasive scourer then apply a thin layer of protective oil or chrome paste.

The glass and all the steel parts must only be cleaned when the appliance is cool, with water and mild detergents.

8 – SMOKE EXHAUST TUBE

8.1 FOREWORD



Due to the frequent accidents caused by poor functioning of flue outlets installed in private dwellings, we have prepared the following paragraph to assist the installer in his inspection of the parts concerned with eliminating the gases produced by combustion.



The exhaust pipe must be installed in compliance with regulations UNI 7129, UNI 10683, and with the stated reference values. In particular, the outlet must comply with fire prevention regulations.

It is important to carefully follow the instructions set out below: failure to observe these instructions could cause serious damage to the product, to the system, to objects and to persons using the appliance.

8.2 ROOM VENTILATION



ATTENTION: the presence of extraction fans or similar appliances, if operating in the same room or space in which the product is installed, could cause problems for the correct operation of the product.

ATTENTION: do not obstruct the vents or the air inlets on the appliance.

The room where the appliance is installed must have a good air flow to guarantee air for the appliance for the combustion process and for ventilation of the room. The natural air flow must take place directly through permanent openings on the outer walls or through single or multiple ventilation ducting.

The ventilation air intake must be located away from pollution sources.

The openings in the walls must comply with the following conditions:

- have an unobstructed section of at least 6cm² for each Kw of installed thermal power, with a minimum limit of 100cm²;
- be made in such a way that the vent openings, both on the inside and outside of the wall, cannot be obstructed;
- be protected with grills or similar systems that do not reduce the opening section indicated above;
- be situated at a height near floor level and they must not obstruct the correct operation of the combustion product discharge devices; if this position is not possible the section of the ventilation openings must be enlarged by at least 50%.



The following chapter is not intended to replace UNI 7129 and UNI 10683 standards. The qualified installer must in any case be fully aware of this standard and its amending versions.

8.3 SMOKE OUTLET



The smoke channel, the exhaust pipe, chimney and flue outlet (defined as the system for the evacuation of combustion products), are parts of the heating system and they must comply with the legislative requirements of the Ministerial Decree D.M. 37/08 (ex Italian Law 46/90) and to the applicable specific installation regulations, according to the type of fuel. Fireplaces, stoves and barbecues must not be installed in locations where gas appliances type A and type B are present and operating (for the classification see UNI 10642 and UNI 7129). The connection between the appliance and the flue outlet must only receive exhaust from one heat generator.



The installer must provide one or more access points on the flue outlet to check the emissions once the appliance has been installed; these access points must be made in such a way as to be air-tight sealable to prevent exhaust gas leaks.



It is recommended to provide insulation and to ensure the optimal sizing of the flue outlet in order to avoid the possible risk of condensation forming in the flue outlet.

8.3.1 CHIMNEY TYPES

The following types of chimneys, constructed as described, are possible:

- System: chimney installed using a combination of compatible components (flue liner, insulation, outer casing, etc...), manufactured or specified by a single manufacturer and EC certified in accordance with the applicable standard;
- Composite chimney: chimney installed and built on site using a combination of compatible components such as flue liner (wall in direct contact with the flue gases), possibly also insulation and outer casing (wall) that may be supplied by different manufacturers or by the same manufacturer;
- Relining: operation involving the installation of a specific pipe in an existing shaft (even if newly constructed) made of non-combustible materials, free from obstructions and for single use.

8.3.2 FLUE OUTLET / FLUE SYSTEM COMPONENTS

Components and accessories of a chimney

Key

- 1 Chimney
- 2 Flow path
- 3 Smoke discharge tube
- 4 Thermal insulation
- 5 External wall
- 6 Outer lining
- 7 Flue outlet section
- 8 Multiwall chimney
- 9 Connector
- 10 Flue pipe
- 11 Heat generator

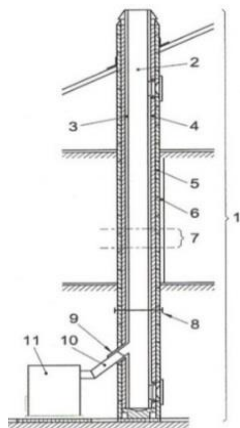

Every chimney must have minimum number of components as laid down by standard UNI EN 1443 which are also indicated in the figure on the side.



ATTENTION: wall outlets, that is outlets installed on the outer front wall without the use of a chimney/flue outlet /flue pipe to convey the combustion products to the roof, are strictly prohibited.

LEGENDA	KEY
COMIGNOLO E CANNA FUMARIA SECONDO NORMA UNI 10683	CHIMNEY CAP AND FLUE OUTLET ACCORDING TO UNI 10683 STANDARD
Tutte le tubazioni devono essere termicamente isolate	All the pipes must be thermally insulated
ISPEZIONE	INSPECTION
ALTEZZA SUPERIORE A 4 metri	HEIGHT MORE THAN 4 m.
Pendenza non inferiore al 5%	Minimum slope 5%
2 metri MAX	2 metres MAX
2-3 metri MAX	2-3 metres MAX.

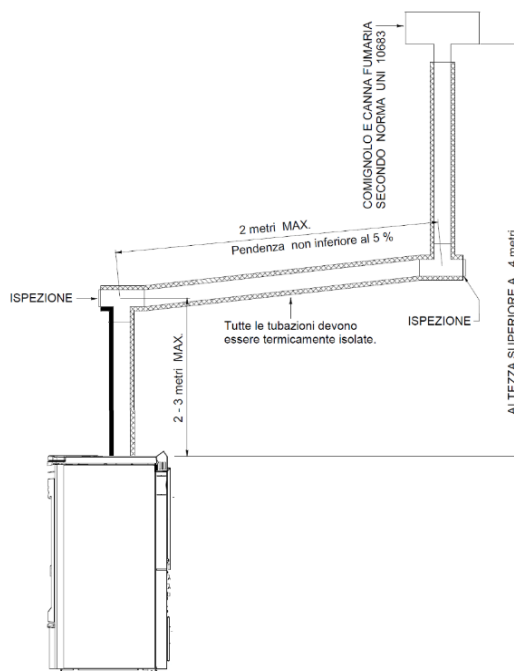

8.3.3 CONTROLS PRIOR TO INSTALLING THE APPLIANCE

The user must possess a certificate of conformance for the flue outlet (Ministerial Decree 22 January 2008, no. 37).

The flue outlet must be built in compliance with UNI 10683.

The smoke exhaust illustrated in the figure on the side is the best solution required to ensure that the flue gases are discharged. If you prefer to exhaust the smoke from the roof insert a union tee with inspection cap, connecting brackets suitable for the height of the flue outlet, flashing that crosses the roof and chimney cap to protect against bad weather conditions.

If you decide to use the classic masonry exhaust provide a union tee with inspection cap and suitable supporting brackets. If the flue outlet is too big it is necessary to insert a stainless steel or porcelain-coated steel tube with suitable diameter.

Seal area where the inlet and outlet part of the smoke exhaust meets the wall. It is strictly forbidden to apply mesh to the end of the outlet tube, as it could cause the appliance to malfunction.

If the smoke tube is installed in a fixed position, it is advisable to provide inspection openings for clean-out purposes especially in the horizontal sections.

See the diagram. These openings are essential to allow for the removal of ash and unburned products which tend to accumulate along the discharge path. Seal the fittings with red silicone (resistant to 350°C).

The outer casing of the tube must be made with insulating material (mineral wool, ceramic fiber) or use pre-insulated tubing.

THE FLUE OUTLET MUST BE USED ONLY FOR THE APPLIANCE.

It must be possible to inspect and remove all the smoke tube sections for clean-out purposes.



ATTENTION: if the flue outlet is not sufficiently insulated and /or if it is too long it could generate condensation. It is advisable to provide a condensation drain near the smoke outlet of the appliance. The appliance must always and only be installed in a single flue outlet system dedicated exclusively to the appliance.

If the generator is connected to a non-compliant flue system the appliance could rapidly deteriorate due to an abnormal, continuous overheating: in this case the damaged parts will not be covered by warranty.

IF THE CHIMNEY CATCHES FIRE, CLOSE THE PRIMARY AND SECONDARY AIR LEVERS IMMEDIATELY AND CALL THE FIRE BRIGADE.

9 – PROBLEMS, CAUSES AND SOLUTIONS

PROBLEM	CAUSE	SOLUTION
Difficulty in lighting the cooker.	Blocked grate.	Clean the grate.
	Moist wood or too thick.	Use smaller sized and more seasoned wood.
	Poor draught.	Clean the ash pan. Remove the cooktop and thoroughly clean the flue gas path and the flue outlet Check the flue pipe: <ul style="list-style-type: none"> • for constrictions • too many curves • bad insulation • section too small
Smoke in the room. Difficulty maintaining the fire. The oven is not heating properly. Low cooktop temperature. Flame insensitive to draft variations. Puffs while operating.	Poor draught.	Clean the ash pan and all the inspection drawers. Remove the cooktop and thoroughly clean the smoke channel. Clean (or have someone clean) the flue. Check the flue pipe: <ul style="list-style-type: none"> • for constrictions • too many curves • bad insulation • section too small
	No air in the room.	Create an adequate opening for the air.
	Moist wood or too thick.	Use smaller sized and more seasoned wood.
Cooktop oxidised.	Poor maintenance of the cooktop.	Clean and maintain the cooktop.
	Corrosive environment for metals.	Install in a non-oxidizing environment.
The fuel is burning too quickly, uncontrolled combustion.	Excessive draught.	Reduce draught of the flue outlet by installing a suitable device (e.g., draught regulator).
The cooktop has warped. The oven thermometers have drifted or yellowed. The handles have warped. Broken components inside the combustion chamber.	Excessive consumption of wood, more than the amount indicated in this manual. Incorrect use of the appliance. No or poor cleaning of the appliance.	Contact a service centre to restore the appliance for a fee then use the appliance as instructed in this manual and comply with all the supplied instructions.

IF THE RECOMMENDED REMEDIES DO NOT SOLVE THE PROBLEM, CONTACT A QUALIFIED TECHNICAL ASSISTANCE SERVICE.



THERMOROSSI 

Fire Lovers

THERMOROSSI S.p.A.

Via Grumolo, 4 (Z.I.) 36011 Arsiero (VI) - ITALY

Fax 0445.741657 - www.thermorossi.com - info@thermorossi.it