



# **THERMOROSSI**

HEATING TECHNOLOGY AND INNOVATION

## *INSTALLATION, USE AND MAINTENANCE GUIDE*



***ASPIROMECA LE***

***ASPIROTRONIC LE***

***ASPIROTRONIC COMBI LE***



# CONTENTS

DECLARATION OF CONFORMITY.....	4
1. INTRODUCTION .....	5
1.1 General guidelines .....	5
1.2 Safety guidelines .....	5
1.3 Standards and recommendations.....	6
1.4 Transportation .....	6
2. TECHNICAL CHARACTERISTICS.....	7
2.1 Technical data.....	7
3. GENERAL DESCRIPTION .....	9
3.1 ASPIROTRONIC LE / ASPIROMECC LE wood fired boilers .....	9
4. INSTALLATION.....	10
4.1 Mounting the outer casing on ASPIROTRONIC LE ASPIROMECC LE .....	10
4.2 Mounting the outer casing on ASPIROTRONIC COMBI LE .....	11
4.3 Mounting the electronic panel on ASPIROTRONIC LE .....	12
4.4 Functions of panel on ASPIROTRONIC LE .....	13
4.5 Display panel of ASPIROTRONIC .....	14
4.6 Programs of the ASPIROTRONIC LE panel.....	14
4.7 Electrical connections diagram for ASPIROTRONIC LE .....	15
4.7.1 Diagram of ASPIROTRONIC LE electronic panel .....	16
4.7.2 REMOTE BOARD CONTROL.....	17
4.7.3 Installation of the antenna.....	17
4.7.4 Diagram of ASPIROTRONIC LE panel operation .....	18
4.8 Installation of ASPIROMECC LE electromechanical panel .....	18
4.9 ASPIROMECC LE electromechanical panel functions .....	19
4.9.1 Wiring diagram for ASPIROMECC LE.....	20
4.10 Electrical connections diagram for ASPIROMECC LE.....	21
4.11 Installation of smoke suction unit on ASPIROMECC LE / ASPIROTRONIC LE .....	21
4.12 Installation of safety exchanger/heat exchanger on ASPIROMECC LE/ASPIROTRONIC LE (Optional).....	22
4.13 Guidelines for the hydraulic connections of the LE series boilers .....	22
4.14 Guidelines for the hydraulic connections of the ASPIROTRONIC COMBI LE boiler (Optional) .....	23
4.15 Guidelines for the hydraulic connections of the ASPIROTRONIC LE / ASPIROMECC LE boiler with the boiler tube (optional).....	23
4.16 Example of hydraulic diagram for ASPIROTRONIC LE with DUO-TEC settings .....	24
4.17 Example of hydraulic diagram for ASPIROTRONIC LE with PUFFER-TEC settings.....	24
4.18 Approximate hydraulic diagram of ASPIROTRONIC LE with puffer with first priority to heating system.....	25
5. USE OF THE BOILERS .....	25
5.1 Starting the ASPIROMECC LE boiler .....	25
5.2 Starting the ASPIROTRONIC LE boiler .....	25
5.3 Regulation of the combustion air in ASPIROMECC LE and ASPIROTRONIC LE.....	26
5.4 Refuelling with wood .....	26
5.5 Adjustment of the combustion air damper opening .....	26
5.6 Practical advice and guidelines .....	27
5.7 Wood fuel .....	27
6. TROUBLESHOOTING .....	28
6.1 Troubleshooting for ASPIROMECC LE and ASPIROTRONIC LE boilers .....	28
7. CLEANING AND MAINTENANCE .....	29
7.1 Cleaning and maintaining ASPIROMECC LE and ASPIROTRONIC LE boilers .....	29
7.2 Cleaning and maintaining EURA boilers.....	29



THERMOROSSI S.p.A.  
Via Grumolo. 4  
36011 ARSIERO  
tel: 0445.741310  
fax:0445.741657

## CE DECLARATION OF CONFORMITY

In accordance with the following directives:

European Directive	73/23/EEC and its amending directive	93/68
	89/336/EEC and its amending directives	93/68/EEC
		92/31/EEC
		93/97/EEC

Thermorossi S.p.A., Via Grumolo 4 - ARSIERO (VI), declares that the the boilers belonging to the series ASPIROMECH LE, ASPIROTRONIC LE, ASPIROTRONIC COMBI LE have been designed and manufactured in compliance with the safety requirements of the standards for EC marking.

This declaration refers to the entire range of the specified series.

ARSIERO, 1 March 2003

**THERMOROSSI S.p.A.**

# 1. INTRODUCTION

## 1.1 GENERAL GUIDELINES

- This installation, use and maintenance guide is an integral and essential part of the product and must be kept by the user.
- Before commencing with the installation, use and maintenance of the product, carefully read all the instructions contained in this booklet.
- This appliance must only be used as intended by the manufacturer. Any other use is considered incorrect and therefore hazardous; consequently, the user shall be totally liable for the product if used improperly.
- Installation, maintenance and repairs must be carried out by personnel with professional qualifications and in compliance with current regulatory standards and in accordance with the instructions of the manufacturer of the appliance.  
Use only original spare parts.
- Incorrect installation or poor maintenance could injure or damage people, animals or things; in this case the manufacturer shall be relieved of all responsibility.
- Before commencing any cleaning or maintenance operation ensure that the appliance has been disconnected from the mains power supply by means of the main system switch or some other disconnecting device installed upstream from the appliance.
- The product must be installed in locations suitable for fire-fighting and furnished with all the services (power and outlets) which the appliance requires for a correct and safe operation.
- If the appliance is sold or transferred to another user ensure that the guide is handed over with it.

*Thermorossi S.p.A. maintains the author's rights on these service instructions.*

*The information in this booklet may not be reproduced or given to third parties or used for competitive purposes without the appropriate authorization.*

## 1.2 SAFETY GUIDELINES



### **Personal injury**

This safety symbol identifies important messages throughout the manual. Read the information marked by this symbol carefully as non-observance of this message can cause serious injury to persons using the boiler.



### **Damage to property**

This safety symbol identifies messages or instructions that are fundamental for the boiler and system to function well. To avoid serious damage to the boiler and/or heating system adhere strictly to these instructions.



### **Information**

This symbol indicates important instructions for good functioning of the boiler or system. If this information is not correctly observed, the performance of the boiler and/or system will not be satisfactory.

### 1.3 STANDARDS AND RECOMMENDATIONS

**Normative references:** national and international standards used for the design, industrialization and manufacture of the products described in this manual:

- European Directive 73/23/EEC - CEI 61/50
- European Directive 93/68/EEC - CEI EN 60204
- European Directive 89/336/EEC - CEI 64-8 (IEC 364)



#### RECOMMENDATIONS:

- Before using the appliance, carefully read every section of this instruction manual as knowledge of the information and the regulations contained in it are essential for a correct use of the appliance.
- The connection of the electric panel must be made by skilled personnel; the manufacturer denies all responsibility for damage, even to third parties, if the instructions for the installation, use and maintenance of the appliance are not strictly observed.
- The user is entirely liable for any changes made to the appliance by the user or by third parties on his behalf.
- All the operations required for the installation and maintenance of the appliance before and during its use are the responsibility of the user.



#### GENERAL WARNINGS

- Caution: the appliance must be connected to a system provided with a PE conductor (in compliance with the specifications of 73/23/EEC, 93/98/EEC, concerning low voltage equipment). Before installing the equipment check the efficiency of the earth circuit of the power supply system.
- Caution: the power supply line must have a section which is suitable for the power of the equipment. In any case, the section of the cables must not be less than 1.5 mm<sup>2</sup>. The boiler must be powered with a voltage of 230 V and 50 Hz. Voltage variations which exceed 10% of the nominal value can cause poor functioning or damage the electrical device. Ensure that a suitable differential switch is installed upstream from the appliance.

### 1.4 TRANSPORTATION

#### TRANSPORTATION AND HANDLING

The boiler body must always be in a vertical position when handled and exclusively by means of trolleys. Take special care to protect the electric panel from mechanical impact which could damage it and its correct functioning.

#### STORAGE

The boiler must be stored in dry, sheltered areas; it is inadvisable to store the boiler directly on the floor. The electric panel must be stored in a clean, dry place. It is inadvisable to store the electrical panel for long periods of time.

## 2. TECHNICAL CHARACTERISTICS

### 2.1 TECHNICAL DATA

#### ASPIROMECL

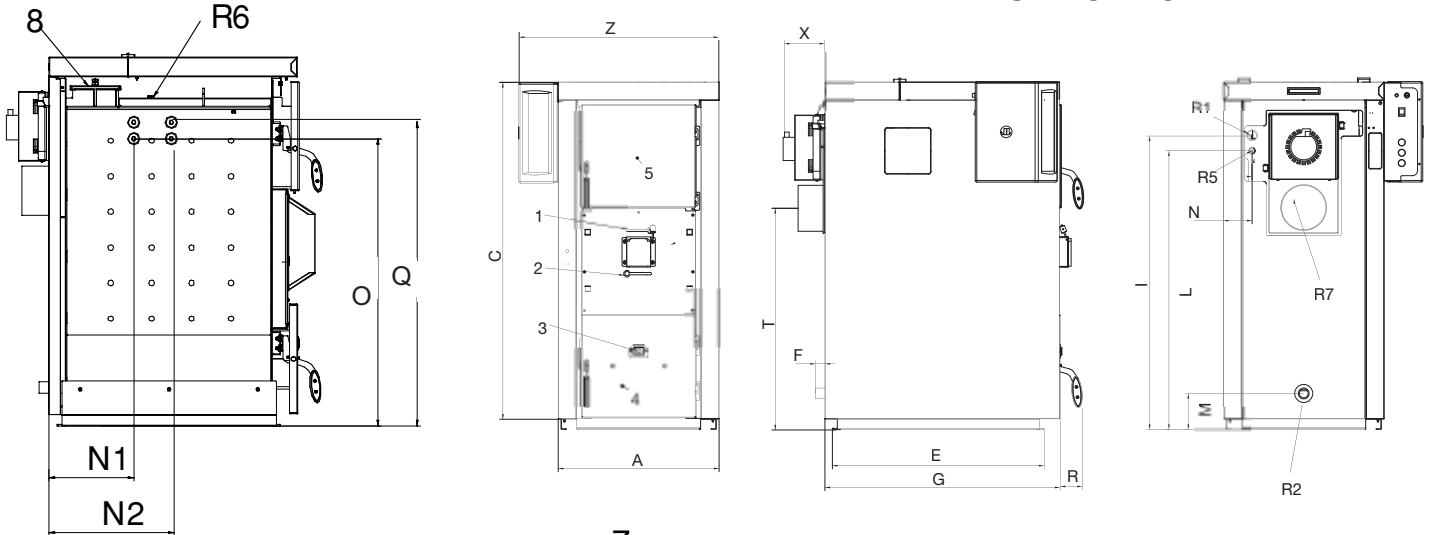

#### ASPIROTRONIC LE

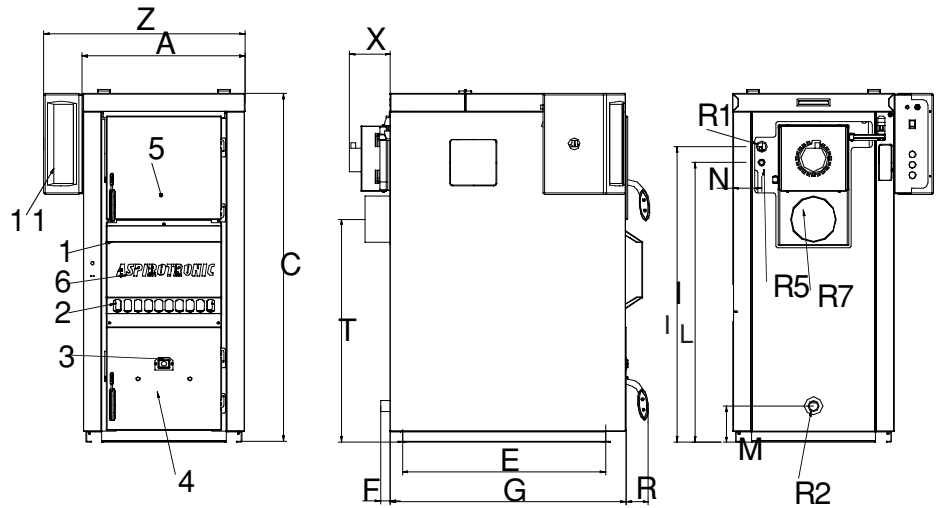

#### ASPIROTRONIC COMBI LE

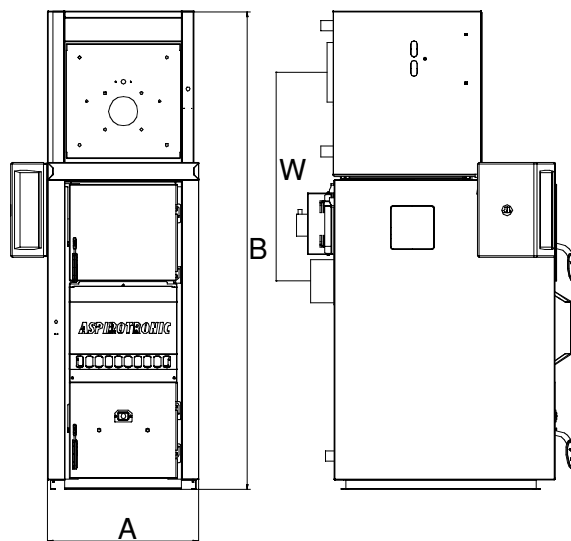

# TECHNICAL CHARACTERISTICS

## DIMENSIONAL TECHNICAL DATA

MODEL	DIMENSIONS IN MM																WEIGHT KG	FLUE OUTLET CONNECTION	DOOR DIMENSIONS mm			
	A	B	C	E	F	G	I	L	M	N	N1	N2	O	Q	R	T				X	Z	W
ASPIROMECC LE 35	623	/	1303	820	37	909	1140	1080	140	112	311	\	1048	1108	90	860	156	775	\	490	180	324x234
ASPIROMECC LE 54	713	/	1435	820	37	909	1270	1210	145	122	304	\	1176	1236	90	980	156	865	\	605	180	354x264
ASPIROMECC LE 73	713	/	1435	984	37	1107	1270	1210	145	122	305	445	1176	1236	90	945	185	865	\	715	180	354x264
ASPIROTRONIC LE 24	623	/	1303	696	37	827	1140	1080	140	112	230	\	1048	1108	90	600	156	775	\	430	180	324x234
ASPIROTRONIC LE 35	623	/	1303	820	37	909	1140	1080	140	112	311	\	1048	1108	90	860	156	775	\	500	180	324x234
ASPIROTRONIC LE 54	713	/	1435	820	37	909	1270	1210	145	122	304	\	1176	1236	90	980	156	865	\	615	180	354x264
ASPIROTRONIC LE 73	713	/	1435	984	37	1107	1270	1210	145	122	305	445	1176	1236	90	945	185	865	\	725	180	354x264
ASPIROTRONIC LE 102	713	/	1435	1354	37	1479	1270	1210	145	122	375	515	1176	1236	90	925	221	865	\	915	200	354x264
ASPIROTRONIC COMBI LE 24	623	1970	/	696	37	827	980	1080	140	112	230	\	1048	1108	90	600	156	775	941	540	180/130	340x260
ASPIROTRONIC COMBI LE 35	623	1970	/	820	37	909	1140	1080	140	112	311	\	1048	1108	90	860	156	775	860	610	180/130	324x234
ASPIROTRONIC COMBI LE 54	713	2180	/	820	37	909	1270	1210	145	122	304	\	1176	1236	90	980	150	865	791	725	180/200	354x264
ASPIROTRONIC COMBI LE 73	713	2180	/	984	37	1107	1270	1210	145	122	305	445	1176	1236	90	945	185	865	826	885	180/200	354x264
ASPIROTRONIC COMBI LE 102	713	2180	/	1354	37	1479	1270	1210	145	122	375	515	1176	1236	90	925	221	865	847	1075	200/200	354x264

MODEL	CONNECTORS			
	Delivery Ø	Return Ø		
ASPIROMECC LE 35	1" x 1/2"	1" x 1/2"		
ASPIROMECC LE 54	1" x 1/2"	1" x 1/2"		
ASPIROMECC LE 73	1" x 1/2"	1" x 1/2"		
ASPIROTRONIC LE 24	1" x 1/2"	1" x 1/2"		
ASPIROTRONIC LE 35	1" x 1/2"	1" x 1/2"		
ASPIROTRONIC LE 54	1" x 1/2"	1" x 1/2"		
ASPIROTRONIC LE 73	1" x 1/2"	1" x 1/2"		
ASPIROTRONIC LE 102	2"	2"		
	SOLIDS	FLUIDS		
ASPIROTRONIC COMBI LE 24	1" x 1/2"	1" x 1/2"	1" x 1/2"	1" x 1/2"
ASPIROTRONIC COMBI LE 35	1" x 1/2"	1" x 1/2"	1" x 1/2"	1" x 1/2"
ASPIROTRONIC COMBI LE 54	1" x 1/2"	1" x 1/2"	1" x 1/2"	1" x 1/2"
ASPIROTRONIC COMBI LE 73	1" x 1/2"	1" x 1/2"	1" x 1/2"	1" x 1/2"
ASPIROTRONIC COMBI LE 102	2"	2"	2"	2"

## TECHNICAL CHARACTERISTICS

MODEL	COMBUSTION CHAMBER POWER Kw(Kcal/h)		MAXIMUM USEFUL HEATING CAPACITY Kw (Kcal/h)		MANIMUM USEFUL HEATING CAPACITY Kw (Kcal/h)
ASPIROMECC LE 35	34.7(30 300)		30 (25.000)		/
ASPIROMECC LE 54	54 (46 800)		44 (38.000)		/
ASPIROMECC LE 73	73 (63 200)		59 (51.000)		/
ASPIROTRONIC LE 24	24 (20 800)		20 (17.300)		13 (11 300)
ASPIROTRONIC LE 35	34.7(30 300)		30 (26.000)		19.5 (16 900)
ASPIROTRONIC LE 54	54 (46 800)		44 (38.000)		28.5 (24.700)
ASPIROTRONIC LE 73	73 (63 200)		59 (51.000)		38 (32 000)
ASPIROTRONIC LE 102	102 (88 400)		82 (71.000)		53 (46 000)
	SOLIDS	FLUIDS	SOLIDS	FLUIDS	
ASPIROTRONIC COMBI LE 24	24(20 800)	34 (29.300)	20(17300)	30 (26.500)	13 (11 300)
ASPIROTRONIC COMBI LE 35	34.7(30 900)	34 (29.300)	30(26 000)	30 (26.500)	19.5 (16 900)
ASPIROTRONIC COMBI LE 54	54(46 800)	52 (42.200)	44(38 100)	44 (38.000)	28.5 (24.700)
ASPIROTRONIC COMBI LE 73	73(63 200)	68 (55.000)	59(51 000)	57 (49.000)	38 (32 900)
ASPIROTRONIC COMBI LE 102	102(88 400)	91 (55.000)	82(71 000)	57 (49.000)	53 (46 000)

MODEL	FUEL BOX VOLUME (dm³)	WATER CONTENT (L)	WORKING PRESSURE (bar)	MAX. FUEL LENGTH (mm)	FLUE OUTLET DRAFT LOSS (mbar)	HEAT EXCHANGER CONNECTIONS Ø	WATERSIDE HEAD LOSS (mbar)	WEIGHT (kg)	COLD WATER PRESSURE REQUIRED BY THE HEAT EXCHANGER			
ASPIROMECC LE 35	113	105	3	530	-0,15	1/2"	0,3	490	2			
ASPIROMECC LE 54	166	150	3	530	-0,15	1/2"	0,6	605	2			
ASPIROMECC LE 73	221	195	3	680	-0,15	1/2"	1,96	715	2			
ASPIROTRONIC LE 24	113	83	3	530	-0,15	1/2"	0,15	420	2			
ASPIROTRONIC LE 35	113	105	3	530	-0,15	1/2"	0,3	500	2			
ASPIROTRONIC LE 54	166	150	3	530	-0,15	1/2"	0,6	615	2			
ASPIROTRONIC LE 73	221	195	3	680	-0,15	1/2"	1,96	725	2			
ASPIROTRONIC LE 102	315	225	3	1000	-0,15	1/2"	3,43	915	2			
ASPIROTRONIC COMBI LE 24	98	83	3	4	530	\	-0,15 -0,15	1/2"	\	0,15	430	2
ASPIROTRONIC COMBI LE 35	113	105	3	4	530	\	-0,15 -0,15	1/2"	\	0,3	610	2
ASPIROTRONIC COMBI LE 54	166	150	3	4	530	\	-0,15 -0,15	1/2"	\	0,6	725	2
ASPIROTRONIC COMBI LE 73	221	195	3	4	680	\	-0,15 -0,15	1/2"	\	1,96	885	2
ASPIROTRONIC COMBI LE 102	315	225	3	4	1000	\	-0,15 -0,15	1/2"	\	3,43	1075	2



### 3. GENERAL DESCRIPTION

#### 3.1 ASPIROTRONIC LE / ASPIROMECC LE WOOD FIRED BOILERS

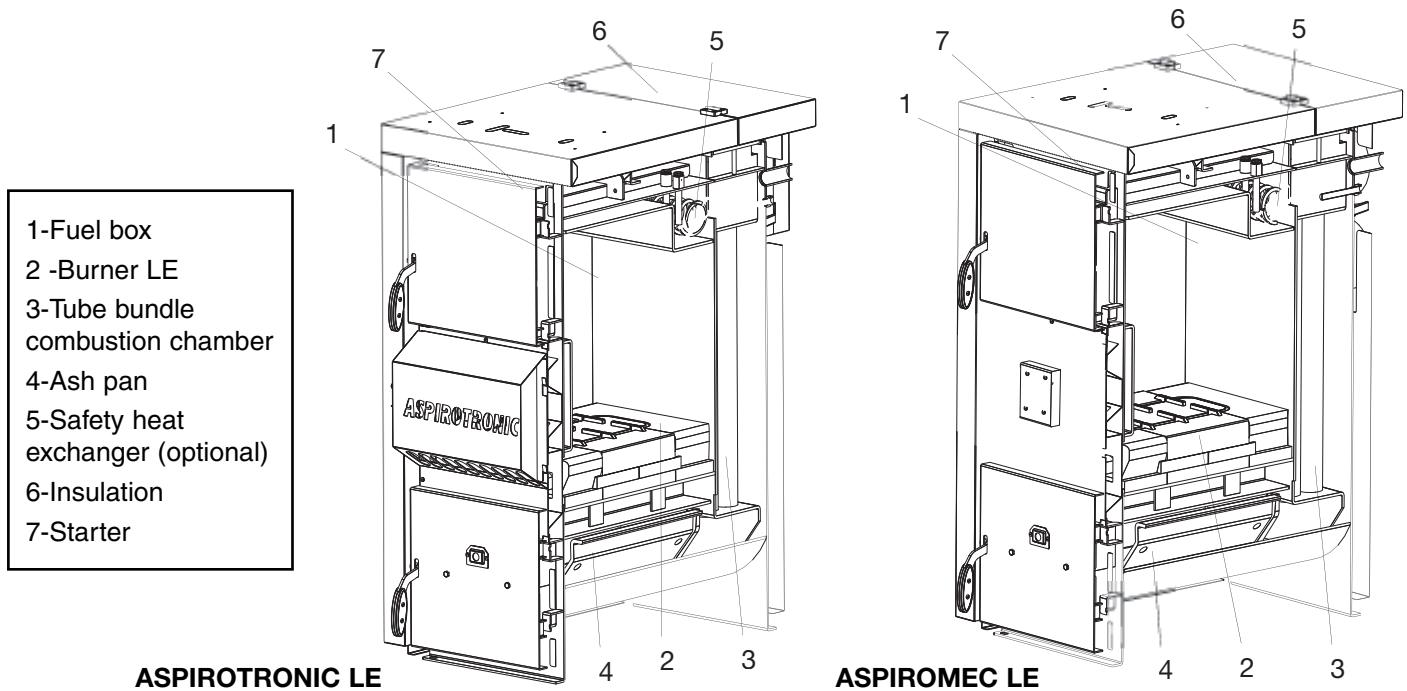

#### FOREWORD

**ASPIROTRONIC LE, ASPIROMECC LE**, are wood fired boilers which operate on the reverse flame principle. The flame is conveyed to the lower part of the boiler by the action of a suction device. The flame develops in the burner referred to as LE. The configuration determines low emissions and an exceptionally regular functioning. The LE burner satisfies the emission limit regulations in major European countries, including Austria which has the strictest regulations concerning polluting emissions (art. 15a B.V.G.).

#### THE BOILER CONSISTS OF :

- 1 - FUEL BOX.** This is where the gasification process (Pyrolysis) takes place, that is the reduction of the wood moisture in simultaneous precombustion with the substances that take part in combustion. It is normal for a layer of tar to be produced in proportion with the quantity of moisture content of the fuel.
- 2 - LE BURNER.** The shape of the burner and the materials used in its construction guarantee the creation of a strong turbulence in the compartment under the burner. Very high temperatures are developed in the LE burner. The symbiosis between temperature and turbulence guarantee low emissions.
- 3 - COMBUSTION CHAMBER.** The combustion chamber is located in the lowest part of the boiler and it is the area on which the ash pan sits.
- 4 - ASH PAN.** The ash is deposited here.
- 5 - SAFETY HEAT EXCHANGER.** ASPIROMECC LE and ASPIROTRONIC LE can be fitted with a safety heat exchanger. If a thermal relief valve is installed it absorbs the excess heat as soon as the boiler, due to external causes, increases to excessively high temperature values. This function is referred to as the fast disconnection phase. If necessary the heat exchanger can be used to produce hot water for domestic use. Limit the duration of this function, as if it is used for a long period of time the boiler will cool down too much. Furthermore, the removal of water must take place together with the operation of the boiler.
- 6 - INSULATION.** The thick layer of mineral wool enveloping the boiler and the insulated outer casing panels guarantee that thermal dispersion is reduced to a minimum.
- 7 - STARTER.** Every time the loading door is opened it activates a direct communication between the fuel box and the smoke outlet.

## 4. INSTALLATION

### 4.1 MOUNTING THE OUTER CASING ON ASPIROTRONIC LE / ASPIROMECC LE.

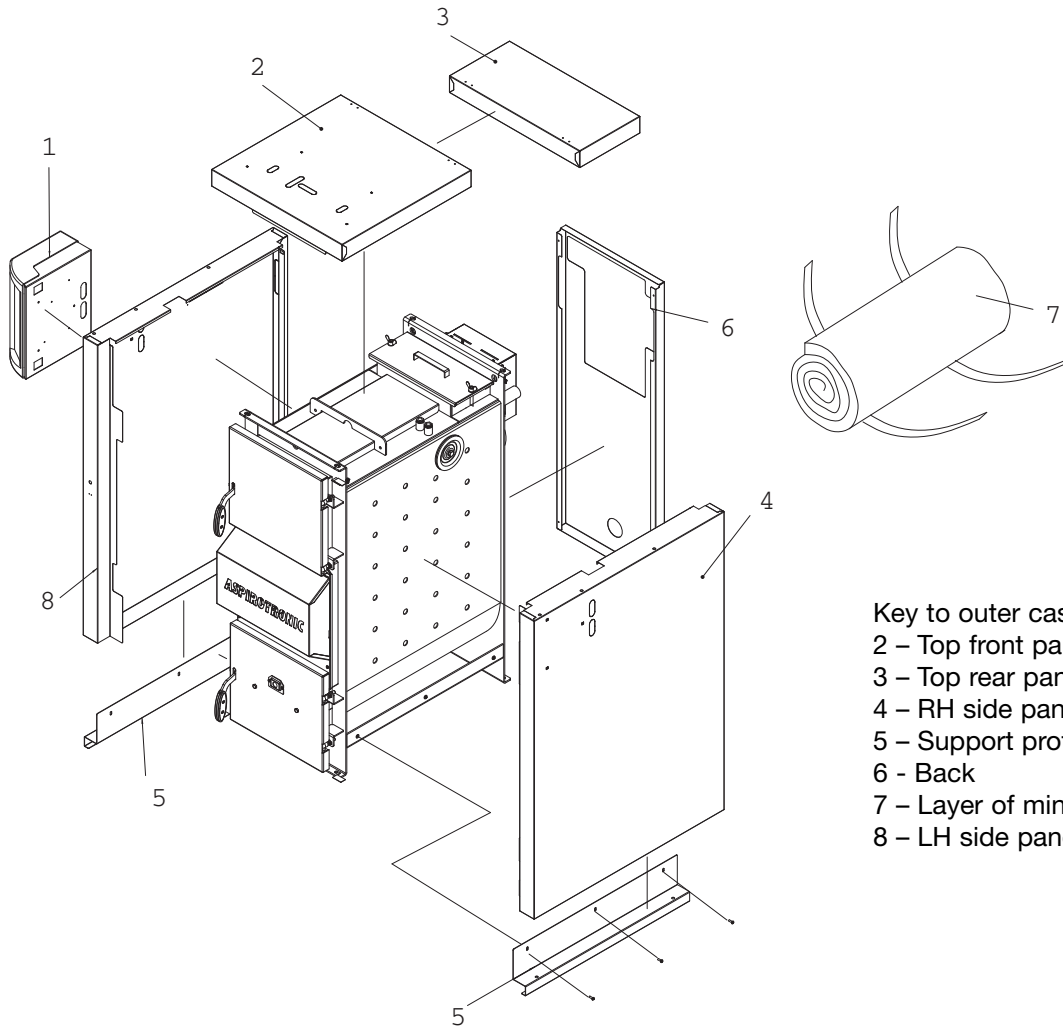

Key to outer casing material:

- 2 - Top front panel
- 3 - Top rear panel
- 4 - RH side panel (2 pieces for model 102)
- 5 - Support profiles
- 6 - Back
- 7 - Layer of mineral wool
- 8 - LH side panel (2 pieces for model 102)

- Wrap the layer of mineral wool (7) around the heater body and fasten it using the strap and fastener; make holes in the mineral wool for the feeler pockets, the tube bundle door and the heat exchanger covers (optional).
- Mount the 2 support profiles (5) using M5x16 screws, washers and nuts.
- Make sure that the RH side panel (4) is correctly mounted on the support profiles then fasten it (for the LE 102 mount 2 side panels).
- Fasten the LH side panel (8), with the smoke suction unit power plug facing towards the back, to the support profile.
- Fasten the top rear panel (3) to the top front panel using the hinges provided and the 4.8x25 screws.
- Lastly, fasten the back panel.

4.2 MOUNTING THE OUTER CASING ON ASPIROTRONIC COMBI LE.

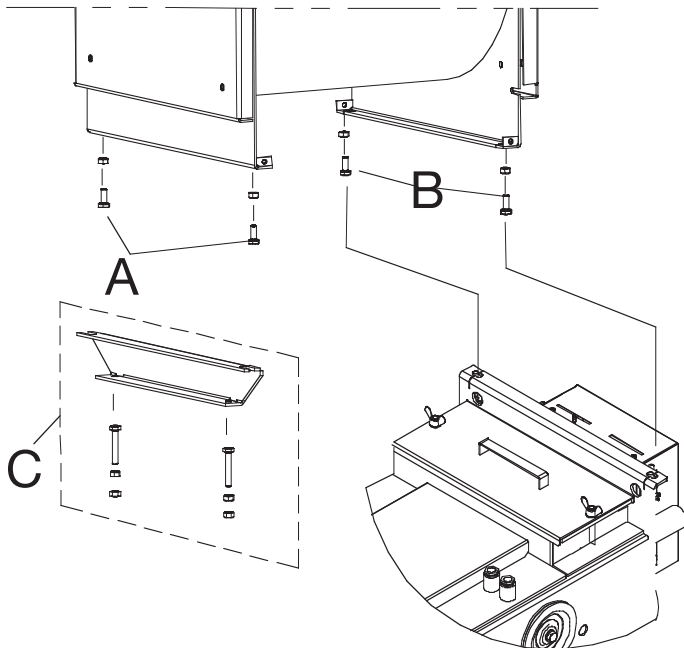

- Mount the outer casing to the boiler as shown in the figure on the previous page.
- Do not mount the top front panel (2); in its place, mount the top rear panel (3) (For LE 102 COMBI use 2 brackets as the Eura boiler, unlike the Aspirotronic boiler, is positioned centrally).
- Disconnect the pins from the front panel and fasten it to the rear panel.
- Fasten the bracket C to the EURA boiler (using screws and nuts A)
- Position the Eura boiler as illustrated in the figure and fasten it to the ASPIROTRONIC boiler (using screws and nuts B).
- Position the EURA boiler and adjust the height by acting on the screws which fasten the bracket B.

**Screws and nuts A, B:** M8x25 hexagon head screws and nuts  
**Screws and nuts C:** M10x60 hexagon head screws and nuts

Follow the diagram below to mount the outer casing of the EURA boiler. Two panels to be mounted at the front and back of the boiler are supplied with boiler LE 102.

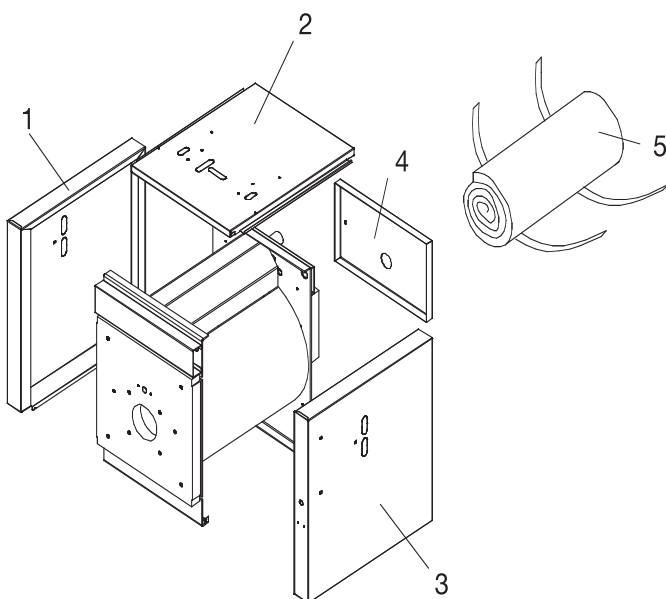

- Wrap the mineral wool (5) around the boiler, secure it using the fasteners provided and make holes for the feeler pockets.
- Mount panels 1 and 3 (the plug must be at the front); insert them inside the 4 brackets on the front panel of the boiler.
- Then mount panel 2 and secure the side panels 1 and 3 using the screws provided.
- Lastly, fasten panel 4.

4.3 MOUNTING THE ELECTRONIC PANEL ON ASPIROTRONIC LE

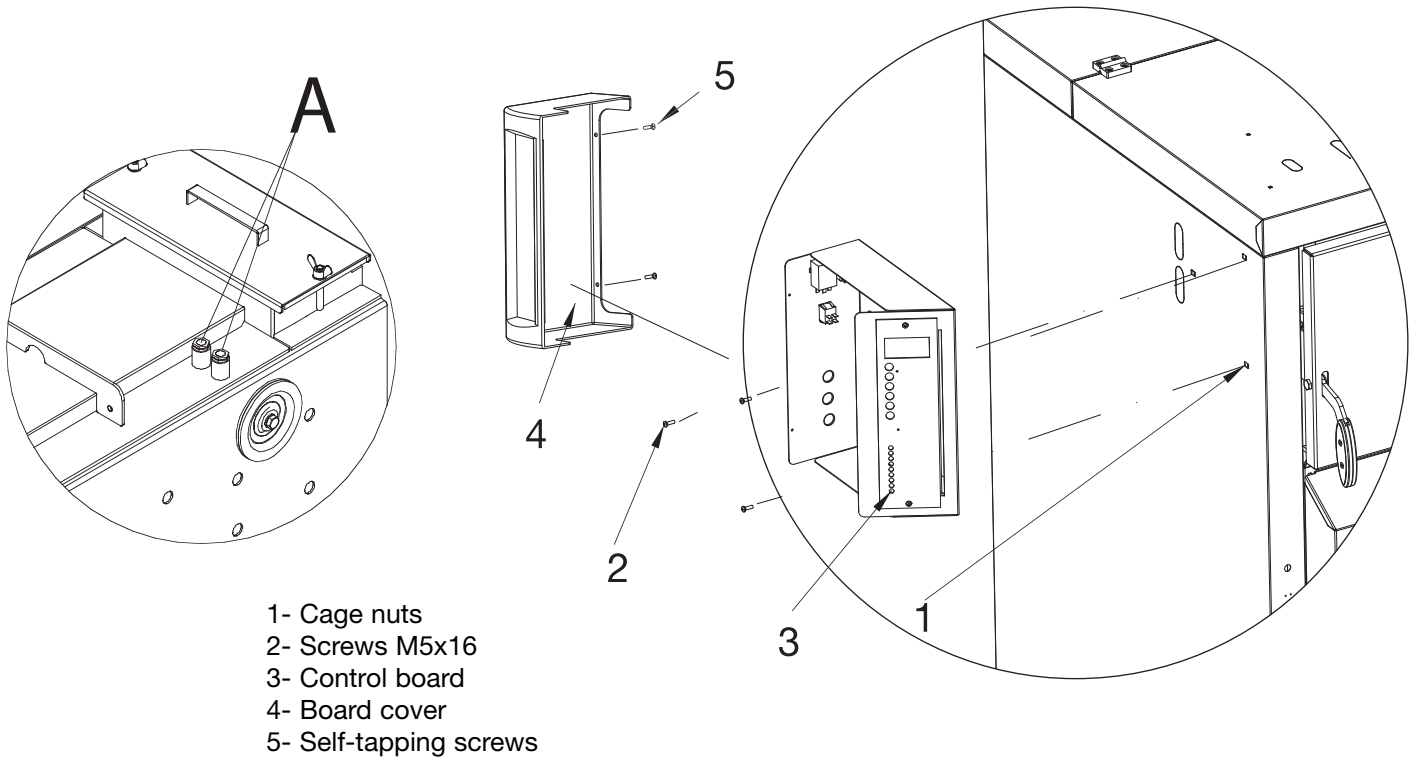

- Fasten the ASPIROTRONIC panel to the left side panel of the boiler. (If mounting it on the right side panel, fix the control board by rotating it by 180° with respect to the panel. Alternatively, the panel can be affixed to the wall).
- Fasten the cage nuts (1) provided in the precut holes.
- Unroll the capillaries and the thermocouple, thread them through the precut holes on the side panels. Thread the end bulbs in the pockets (A) located on the top of the boiler and fill up with lubricating oil to improve the heat exchange.
- Close the panel with the board cover (4) using the screws and nuts (5).
- Insert the rear part and secure the front part with the catch.

#### 4.4 FUNCTIONS OF PANEL ON ASPIROTRONIC LE

The electronic panel is managed by a suitably programmed microprocessor. The microprocessor not only improves the functioning of the boiler, but it also makes it possible to manage the gas-diesel oil boiler with blown burner of the EURA series.

The temperature detection system is controlled by one or two thermocouples (combi version). The large display improves boiler management by making read-outs and functions promptly available.

The main feature of the panel is its capacity to modulate the boiler power according to the energy requirements of the plant. The panel allows the suction unit to vary its speed according to the temperature of the boiler: the modulation of power is obtained by reducing the speed of the smoke suction unit as the temperature in the boiler increases.

#### THE PANEL CONSISTS OF:

- Main illuminated switch located on the back of the panel.
- Manual reset safety thermostat push button (back of panel); if the overtemperature rises above 100°C the burner and fan are shut off. Once the causes leading to the overtemperature have been identified and solved the burner and fan can be reactivated by unscrewing the plastic cover of the thermostat and pressing the button (the boiler temperature must be below 70° C).
- Signal light (back of panel); the light comes on to signal that the manual reset thermostat has tripped.
- Display.
- **START** push button (to start the operating cycle).
- **MIN / MAX** push button . Press the push button to select the **MINIMUM CYCLE**; the min. indicator light comes on to signal that the cycle has been activated. The boiler develops a power which is 35% below the rated power.
- **ECONOMY** push button. When this function is selected the letter “e” appears on the display. The ECONOMY function can be selected in both the MAXIMUM CYCLE and the MINIMUM CYCLE. The maximum speed of the fan is 1800 RPM in this cycle compared to 2700 RPM in the cycles other than the ECONOMY cycles. This function must be used in the in-between season periods with a partial load of wood or to produce hot water for domestic use. The fan operates at maximum working speed until the boiler reaches 60°C. The modulation phase starts at 61°C: the suction unit reduces its rotating speed until it stops as soon as the boiler temperature reaches 78°C. Press the push button to select the **MAXIMUM CYCLE**; the max. indicator light comes on to signal that the cycle has been activated. The boiler operates at maximum power until the temperature reaches 68°C. The fan modulates from 69°C to 82°C which is when it stops.
- **H-H** selection push button. When this button is pressed the letters H-H appear on the display and the fan operates at maximum speed for one minute in whatever situation it happens to be (even if it has shut down due to having reached the temperature).
- **WOOD-AUT.-DIESEL** selection (only for COMBI version). Press this button to select the operating cycle: only wood, only diesel oil or automatic. Each time the button is pressed the corresponding light comes on. The automatic cycle activates the gas-diesel oil burner 30 minutes after the boiler temperature drops below 59°C.
- **DIESEL OIL °C**. Press this button to select the temperature for the burner to shut off. The temperature can be selected from between 65°C-85°C; each time you press the button the temperature increases by 1°C.

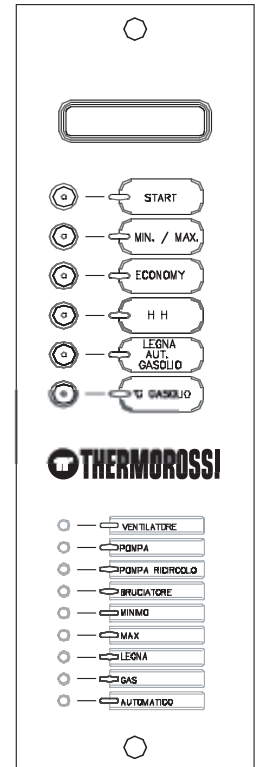

#### 4.5 DISPLAY PANEL OF ASPIROTRONIC

##### OPERATION OF ASPIROTRONIC LE

Symbols appearing on the display:

- Boiler temperature
- ✚ - Wood fuel operation
- ✱ - Smoke suction unit



##### OPERATION OF ASPIROTRONIC COMBI LE

Symbols appearing on the display:

- Boiler temperature
- ✚ - Wood fuel operation
- - Diesel oil fuel operation
- ✱ - Smoke suction unit

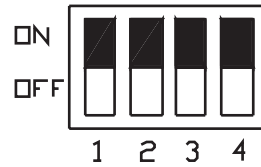

##### OPERATION OF ASPIROTRONIC COMBI LE PUFFER TEC

Symbols appearing on the display:

- Boiler temperature + storage temperature
- ✚ - Wood fuel operation
- - Diesel oil fuel operation
- ✱ - Smoke suction unit



#### 4.6 PROGRAMS OF THE ASPIROTRONIC LE PANEL

The operating program for the panel can be selected according to the plant type. The settings for the dipswitches located on the front panel are shown below (figure below).

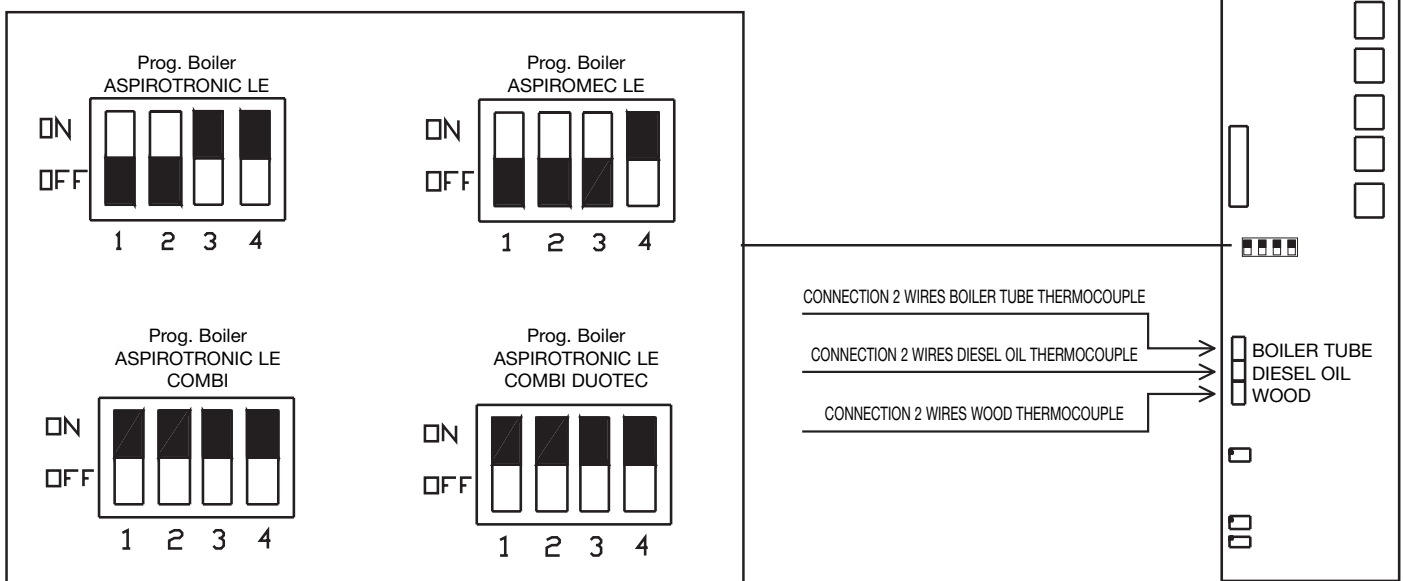

**4.7 ELECTRICAL CONNECTIONS DIAGRAM FOR ASPIROTRONIC LE**

The circuitry consists of 3 terminal boards called M1 M2 M3. The individual contacts are called "pins".

**TERMINAL BOARD M1**

Pins 1-2-3 are used in the combi version with the installation of a 3-way motorised valve which can cut out and isolate the wood fuel boiler when the gas-diesel oil boiler is operating. The switch-over is done by means of the special push button on the panel.

Pins 4 and 5 are used for the room temperature thermostat of the plant circulating pump (pins 6 and 7).

The plant circulating pump will only be activated under the following conditions:

- Room temperature thermostat with closed contact.

- Temperature of the boiler above 61°C.

The power supply (220 V) for the plant circulating pump is delivered from pins 6, 7.

The plant circulating pump also functions as a thermal safety device: if the temperature in the boiler rises above 90°C the plant circulating pump is activated automatically.

**TERMINAL BOARD M2**

The M2 terminal board is used when a boiler tube is installed for the production of hot water for domestic use.

For priority to domestic hot water install a thermostat connected to pins 1,2,4.

It is mandatory to connect all the contacts: common, N.C., N.O.. Pins 3 and 5 are dedicated to energising the boiler tube pump (220 V).

**TERMINAL BOARD M3**

Pins 1, 2 (220 V) are used for additional circulating pumps.

The circulating pumps are only activated if the boiler temperature reaches or exceeds 61°C.

Pins 3 and 4 are used for the recycling pump connected between the delivery and the return (to prevent heat stratification of the water in the boiler). This pump operates when the wood fired boiler is active. Pins 5 and 6 (220V) are used to power the gas-diesel oil burner. Pins 7 and 8 are dedicated to powering the suction unit.

Pins 9, 10, 11 are dedicated to an exchange valve when the thermal safety device is activated.

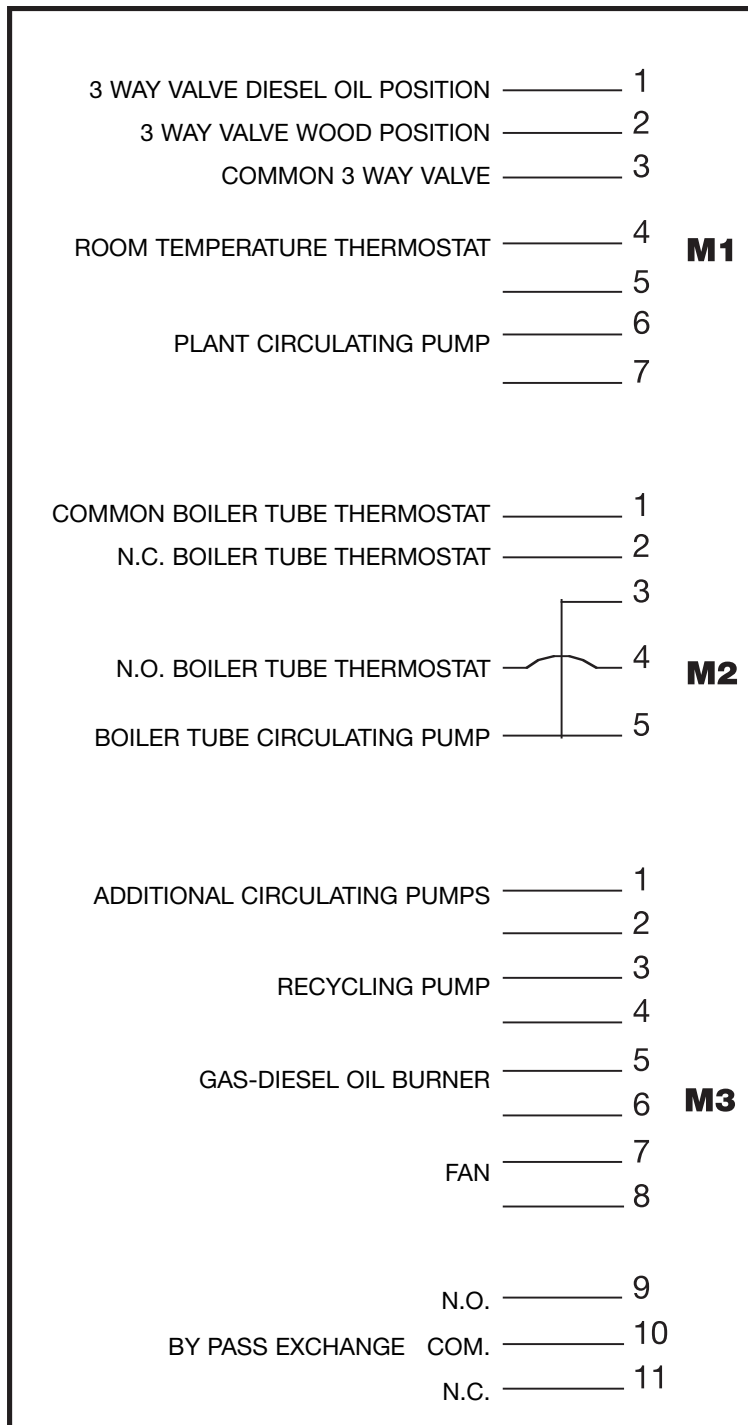

4.7.1 DIAGRAM OF ASPIROTRONIC LE ELECTRONIC PANEL

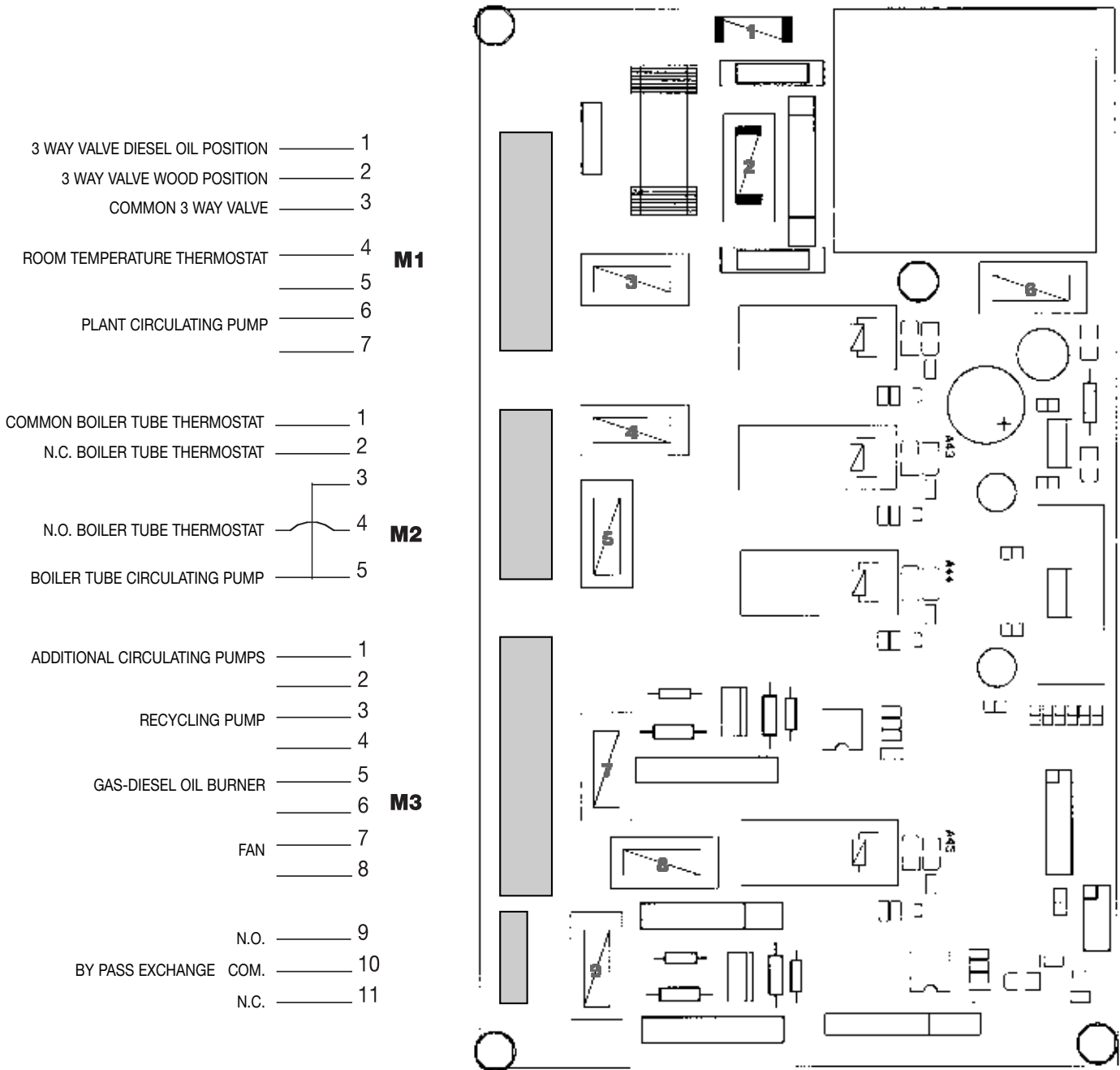

The fuses on the power board are shown in the diagram:

- 1) 220 V safety fuse
- 2) General safety fuse
- 3) 3 way valve fuse
- 4) By pass fuse
- 5) Circulating pump fuse
- 6) Low voltage fuse
- 7) Recycling pump fuse
- 8) Burner fuse
- 9) Smoke suction unit fuse

**N.B.:** If the room temperature thermostat is not used install a jumper between terminals 4 and 5 on terminal board M1.  
**N.B.:** If the boiler tube is not used install a jumper between terminals 1 and 4 on terminal board M2.



#### 4.7.2 REMOTE BOARD CONTROL

Allows you to view the main parameters of the generator on a separate unit (Remote Board Control). The data is transmitted on radio waves. The unit is powered with the help of a transformer 220 – 7.5 V (supplied).

#### 4.7.3 INSTALLATION OF THE ANTENNA

Installation of the antenna on the control board for the "Remote Board Control" (only on ASPIROTRONIC version). The transmitting antenna must be installed in order to be able to transmit the main parameters from the control panel to the "Remote Board Control".

Fasten the antenna to the top part of the panel, as shown in the photos.

Insert the transmitting module on the connection board.

At this point the antenna is connected to the control board.

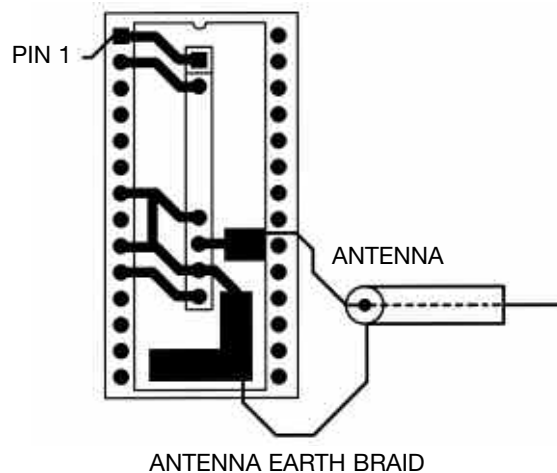
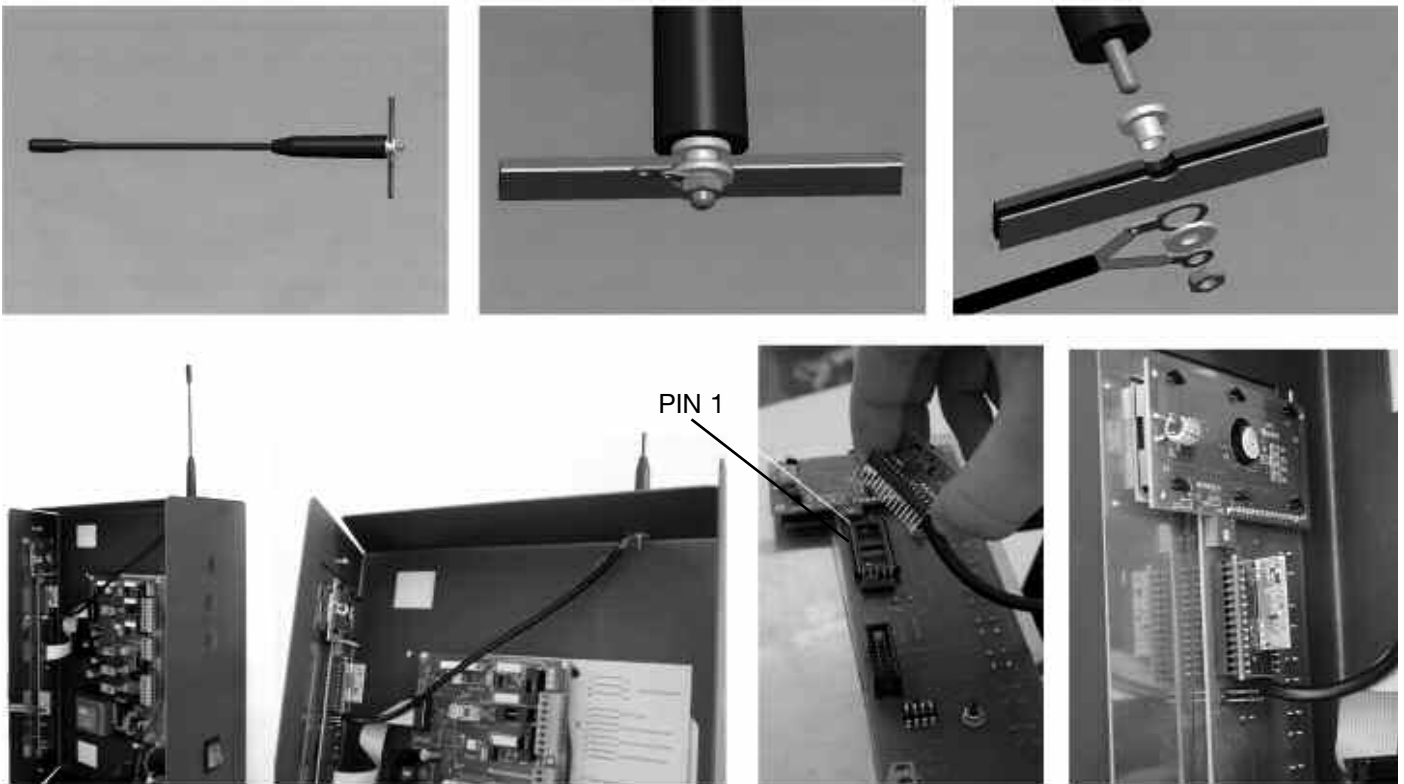

4.7.4 INSTALLATION OF THE ANTENNA

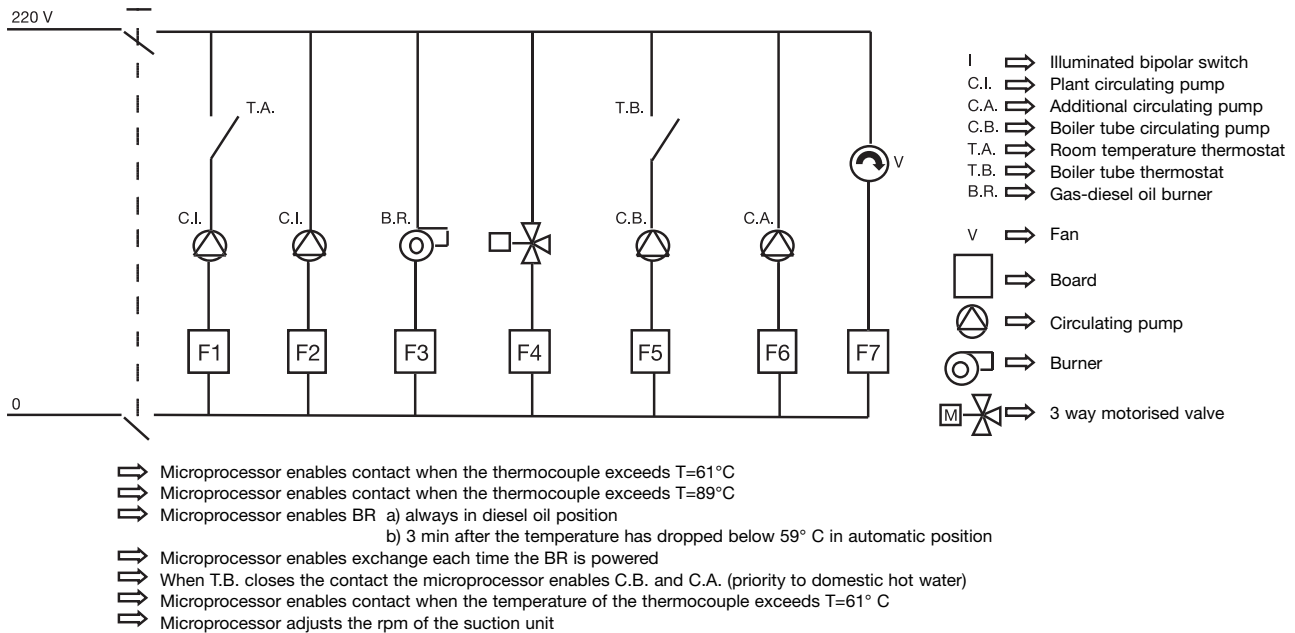

4.8 INSTALLATION OF ASPIROMECA LE ELECTROMECHANICAL PANEL

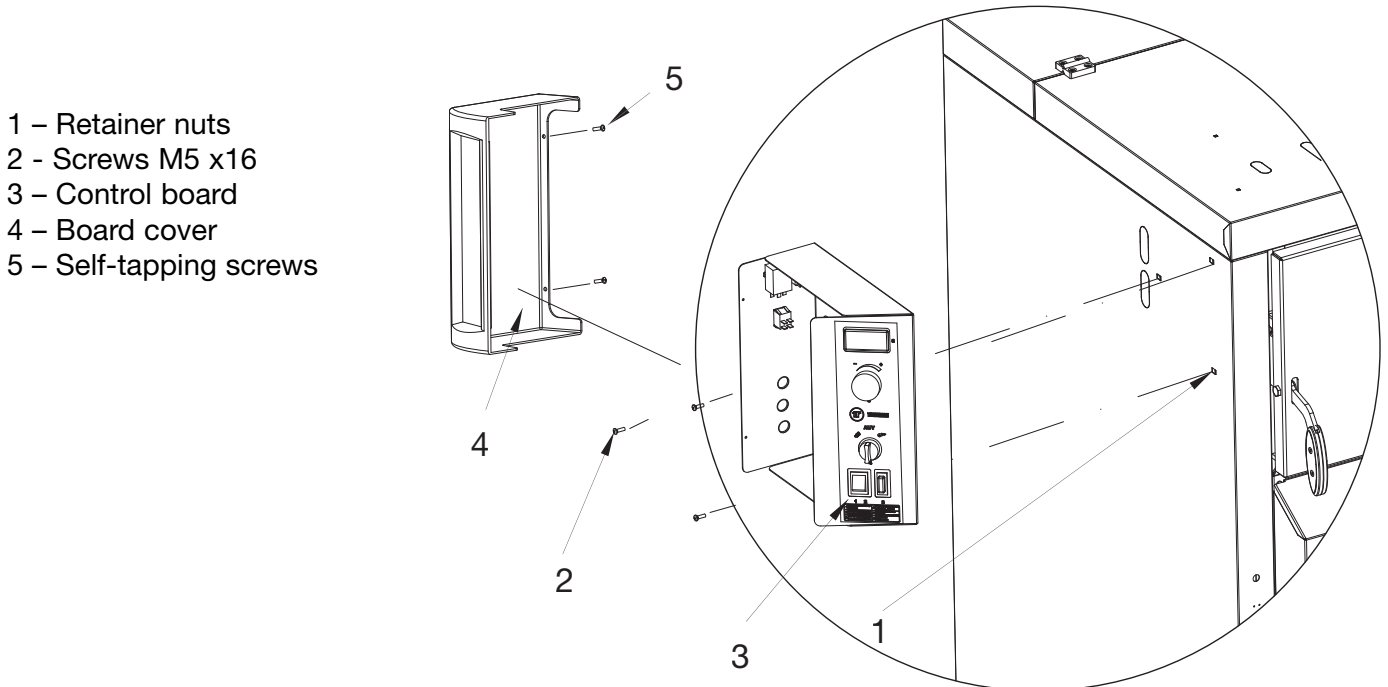

Fasten the ASPIROMECA LE panel to the front cover of the boiler.  
Use the supplied screws and nuts (3) to fasten the panel with cover after having made all the necessary connections: unwind the capillaries, thread them through the pre-cut holes in the side right or left, insert the end bulbs in the pockets (A) located on the top of the boiler and fill up with lubricating oil to improve the exchange.

#### 4.9 ASPIROMECC LE ELECTROMECHANICAL PANEL FUNCTIONS

**The control panel consists of the following parts:**

- 1 – Main and cycle start switch (illuminated).
- 2 – Boiler fan control switch.
- 3 – Heating plant circulating pump control switch.
- 4 – Wood cycle start and fuel finished signal light. This light comes on when the fuel finished thermostat signals a drop in the water temperature caused by a lack of firewood. The thermostat is located inside the electric panel and is calibrated at 45° C. Once the wood load finishes the light comes on and the fan shuts off.
- 5 – Manual reset safety thermostat; when the overtemperature goes above 100° C the fan shuts off. Once the reasons for this overtemperature have been identified and resolved the fan can be reactivated by unscrewing the plastic cover on the thermostat and pressing the button (the temperature of the boiler must be below 70° C).
- 6 – Thermostat for regulating the boiler water temperature (from 70 to 90° C). The manufacturer recommends keeping the boiler water temperature on high values (75° C /80° C) in order to prevent the formation of condensation.
- 7 – Thermometer.

**The following devices are located inside the electric panel:**

- Forced circulation (bypass) thermostat calibrated at 90°C. This is a safety device which prevents the boiler water from boiling by activating the circulating pump for a few seconds, even without the signal from the room temperature thermostat.
- Anticondensation thermostat (Calibrated at 60°C)
- Fuel finished thermostat (Calibrated at 45°C)
- Relay.

**Operation:**

The operation of the fan is indispensable for intaking air required for the combustion in the boiler. The fan functions if switch 2 is positioned on "1".

The air intake is always the maximum and it only stops when the set point temperature of the boiler thermostat is reached. The pumps must always be connected to the panel as they are activated above 60°C. When the wood fuel is about to finish, the water temperature tends to drop and eventually shuts down the pump as the anticondensation thermostat is tripped. The fan continues to operate without producing any further heat and cools the boiler body. When, as a result of this cooling process the temperature drops to roughly 45°C, the fuel finished thermostat is tripped, which in turn shuts down the fan. In the initial starting phase when the boiler is cold the fuel finished device could be activated even if the boiler is lit and running on a full load of wood.

**This occurs when:**

- The circulators are not connected to the electric board but by means of external collar thermostats. The poor sensitivity of these thermostats can allow the pumps to operate to the point where the water temperature in the boiler drops below 45°C which trips the fuel finished thermostat.
- The overall capacity of the pumps is so high that when they start at 60°C for the first time, the water refill is so fast that the cold water return from the plant is not signalled in time by the anticondensation thermostat, consequently the temperature drops below 45°C, which in this case as well, trips the fuel finished thermostat.

To remedy this situation in this case simply reduce the pump speed, or throttle its flow capacity.

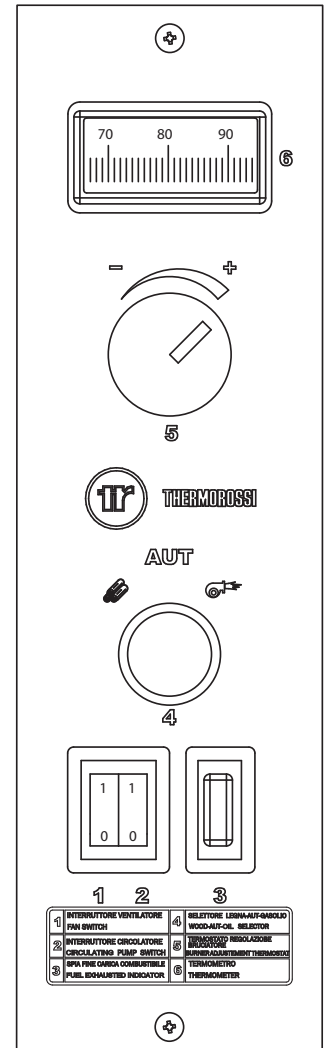

4.9.1 WIRING DIAGRAM FOR ASPIROMECE LE

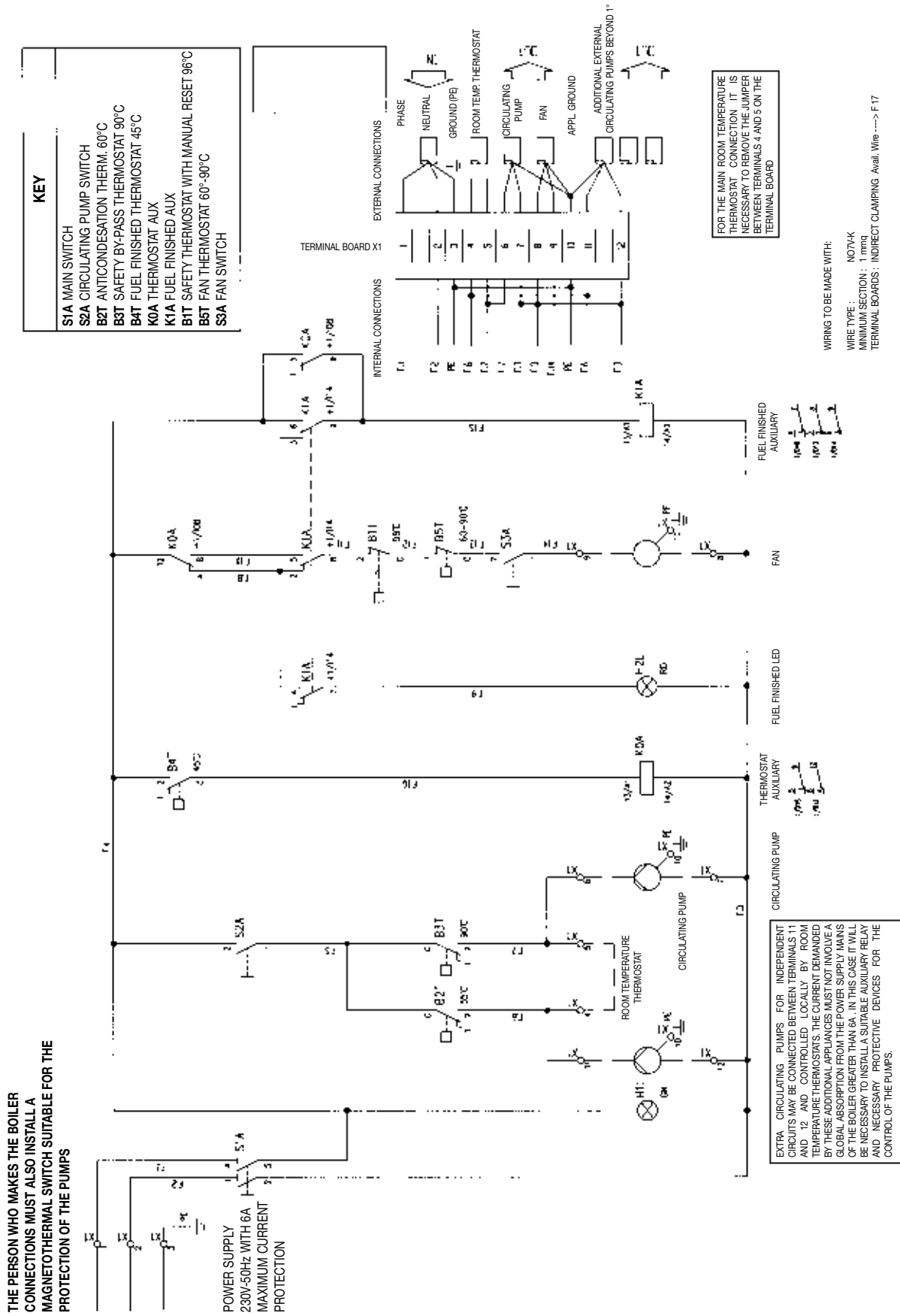

**4.10 ELECTRICAL CONNECTIONS DIAGRAM FOR ASPIROMECC LE**

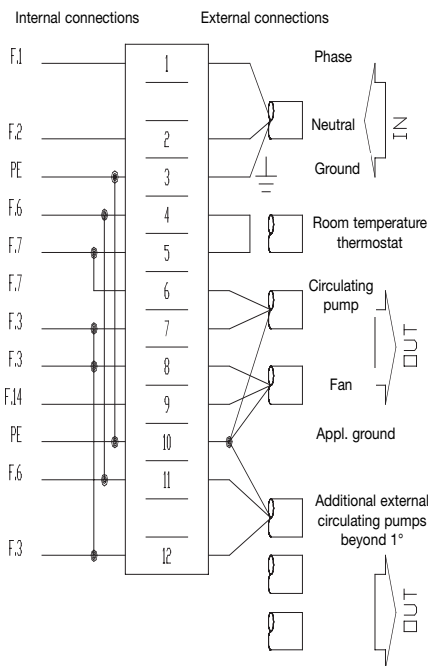

See the diagram on the right for the connections of the power supply, the circulating pump, the fan and the additional circulating pumps. If the plant is only equipped with one circulating plant and one room temperature thermostat then the first must be connected to terminal pins 6 and 7 and the second to pins 4 and 5.

Connections which are different to those indicated and arbitrary modifications void the warranty.

If, on the other hand, the plant consists of several areas fed by the same number of circulating pumps then one area and its corresponding circulating pump and room temperature thermostat must be selected to function as a thermal safety device.

These are to be connected as described above to pins 6-7 and 4-5.

All the other circulating pumps will have to be connected directly to pins 11 and 12, if the overall load does not exceed 5 Amperes, or by means of relays if the load is greater.

The corresponding room temperature thermostats must be inserted in series on the corresponding power supply lines. This type of connection will guarantee that the circulating pumps function as anticondensation devices and consequently will not be able to function if the water in the boiler is below 60° C.

**4.11 INSTALLATION OF SMOKE SUCTION UNIT ON ASPIROMECC LE / ASPIROTRONIC LE**

Install the smoke suction unit after mounting the outer casing.

Firstly mount the ceramic fibre gasket (2). Then mount the smoke suction unit (1) on the centring pins on the boiler.

Then secure it using the fasteners on the boiler.

Make sure that after it has been secured the safety spring on the fasteners is attached; this prevents the smoke suction unit from accidentally coming off.

Then connect the unit plug.

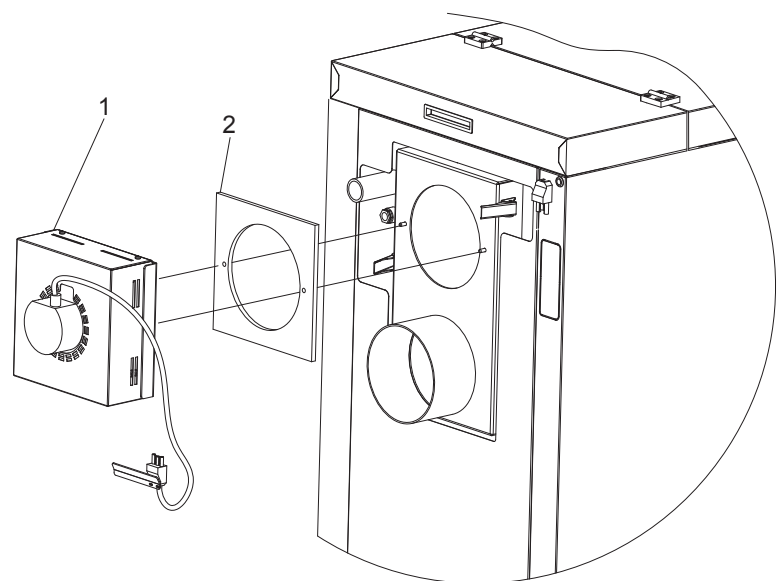

**4.12 INSTALLATION OF SAFETY EXCHANGER / HEAT EXCHANGER ON ASPIROMECC LE ASPIROTRONIC LE (OPTIONAL).**

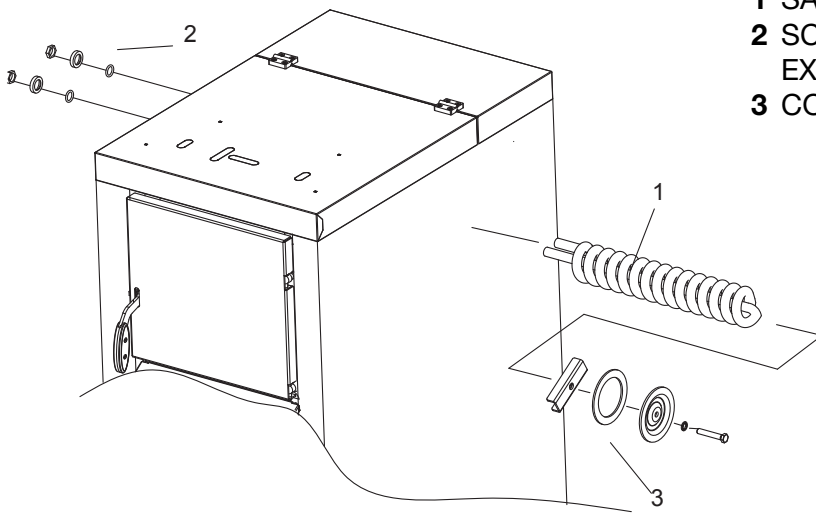

- 1 SAFETY EXCHANGER / HEAT EXCHANGER
- 2 SCREWS AND NUTS FOR FASTENING EXCHANGER INLET-OUTLET
- 3 COVER

Remove the precut covers from the exchanger holes on the side panels of the outer casing; also remove the rectangular precut cover from the left side panel (see image on previous page) located on the back of the panel: this opening is used for the hydraulic connections to the exchanger.

Remove the cover (3) and remove the covers on the opposite side panel.

Insert the exchanger (1) and secure it to

the boiler using the screws and nuts provided (2).

Close the hole with the cover (3).

By installing the thermal relief valve the excess heat is absorbed as soon as the boiler, for external reasons, rises to temperature values which are far too high. This function is referred to as fast disconnection phase.

Whenever it is necessary the exchanger can be used to produce hot water for domestic use. This use of the exchanger must not last too long an amount of time as otherwise the boiler will cool down too much. Furthermore, the removal of the water must be simultaneous with the operation of the boiler.

**4.13 GUIDELINES FOR THE HYDRAULIC CONNECTIONS OF THE LE SERIES BOILERS**

Safety standards stipulate that solid fuel fired boilers can only be installed in plants with an open expansion tank.

- They must be equipped with:
- a) **Open expansion tank**
  - b) **Safety tube with suitable section**
  - c) **Feed tube for water to refill the boiler**
  - d) **Thermal safety relief valve**

The safety tube (b) must be connected to the boiler delivery tube and no cutoff devices must be installed on it. Its path from the boiler to the open expansion tank must be as short as possible and must never have descending sections or sections with siphons.

The sensitive bulb of the thermal relief valve with capillaries must be inserted in the special pocket situated under the boiler delivery tube.

The thermal relief valve disposes of the excess heat if there is an excessive increase in the temperature of the water in the boiler.

If the boiler is fitted with a heat exchanger for the production of hot water for domestic use, the thermal relief valve will have to be installed at its outlet. A safety valve calibrated at 6 bar must also be installed at the heat exchanger outlet.

It is extremely important that the plant does not display any natural circulation phenomena as until the water has a temperature below 55-60°C, the humidity contained in the smoke would condensate inside the boiler. The condensation is acidic and consequently corrosive which is extremely damaging for the steel walls of the boiler, especially those not protected by vitrification.

Therefore, plants with natural circulation must be fitted with a nonreturn valve downstream from each circulating pump.

**4.14 GUIDELINES FOR THE HYDRAULIC CONNECTIONS OF THE ASPIROTRONIC COMBI LE BOILER WITH BOILER TUBE (OPTIONAL)**

The connections to be made are shown in the following diagram:

- A:** Heating system delivery
- R:** Heating system return
- P:** Connection of wood fired boiler delivery to gas-diesel oil boiler EURA return
- E:** Safety tube that connects the boiler to the open expansion tank
- S:** Boiler drain
- L:** 1" water recycling tube
- V:** 3 way motorised deviator valve
- PC:** Plant circulating pump
- PR:** Boiler water recycling pump
- VI:** On-off valve
- VNR:** Nonreturn valve
- VST:** Thermal relief valve
- VS:** Safety valve

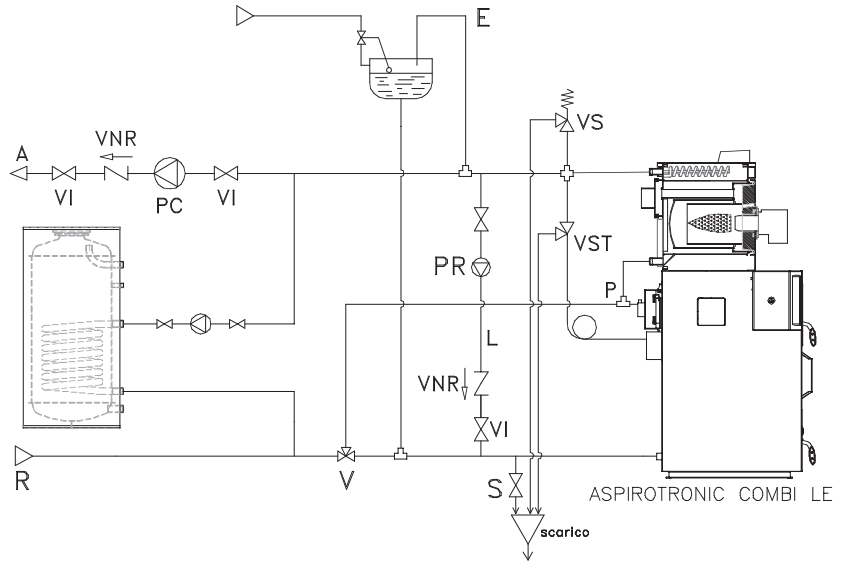

**4.15 GUIDELINES FOR THE HYDRAULIC CONNECTIONS OF THE ASPIROTRONIC LE ASPIROMECH LE BOILER WITH BOILER TUBE (OPTIONAL)**

The connections to be made are shown in the following diagram:

- A:** Heating system delivery
- R:** Heating system return
- E:** Safety tube that connects the boiler to the open expansion tank
- S:** Boiler drain
- PC:** Plant circulating pump
- VI:** On-off valve
- VNR:** Nonreturn valve
- VST:** Thermal relief valve
- VS:** Safety valve
- PR:** Boiler water circulating pump

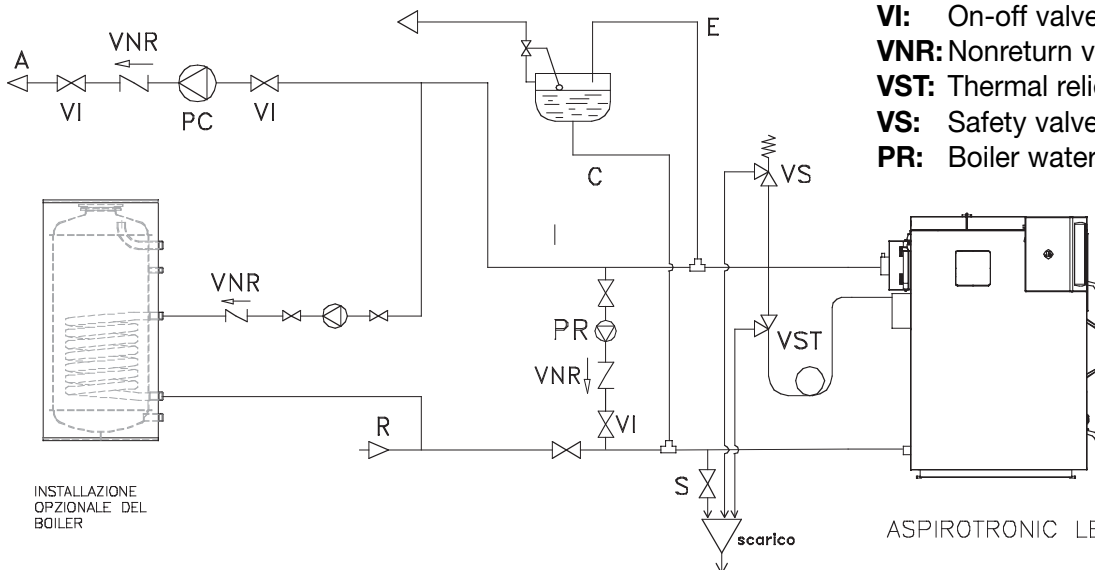

**4.16 EXAMPLE OF HYDRAULIC DIAGRAM FOR ASPIROTRONIC LE WITH DUO-TEC SETTINGS**

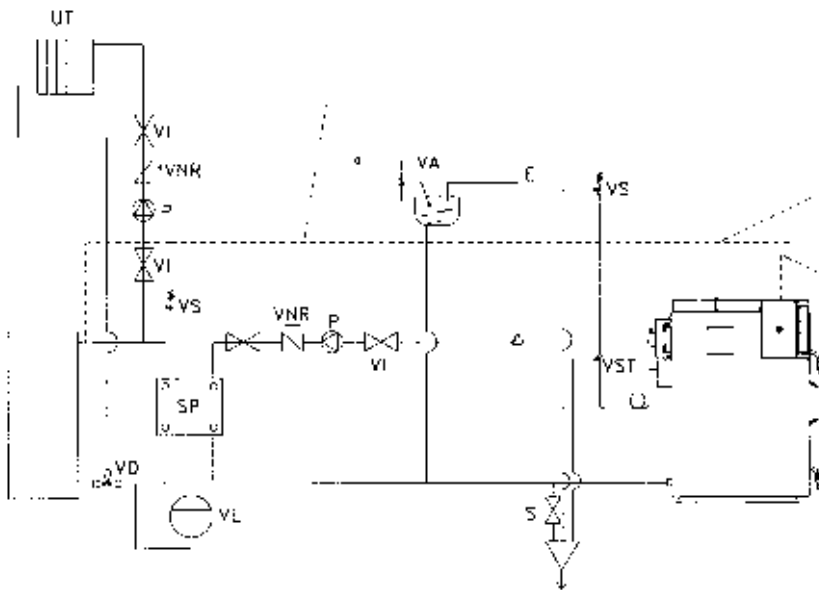

- P:** Pump
- UT:** Radiators
- VE:** Expansion tank preloaded at 1.5 bar
- VA:** Open expansion tank
- SP:** Heat exchanger (e.g: plate-type exchanger)
- E:** Safety tube that connects the boiler to the open expansion tank
- S:** Boiler drain
- PC:** Plant circulating pump
- VI:** On-off valve
- VNR:** Nonreturn valve
- VST:** Thermal relief valve
- VS:** Safety valve
- VD:** Deviator valve

**4.16.1 OPERATION OF PUMP P WITH PUFFER-TEC SETTINGS**

P operates as follows: if the boiler temperature is 7°C above the temperature of the puffer pump P operates. Vice versa if the temperature of the puffer is 7°C higher than the temperature of the boiler pump P stops. The functions of the other terminal boards are described on page 15.

**4.17 EXAMPLE OF HYDRAULIC DIAGRAM FOR ASPIROTRONIC LE WITH PUFFER – TEC SETTINGS.**

- P:** Recycling pump (enabled by the 2 thermocouples)
- UT:** Radiators
- P1:** Plant circulating pump
- VS:** Safety valve
- VST:** Thermal relief valve
- S:** Boiler drain
- VI:** On-off valve
- VNR:** Nonreturn valve
- E:** Safety tube that connects the boiler to the open expansion tank
- VA:** Open expansion tank

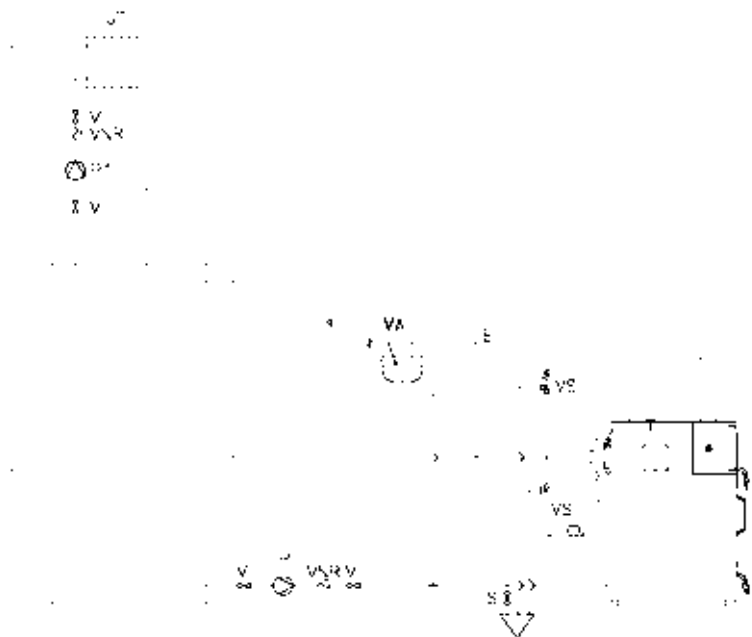



**4.18 APPROXIMATE HYDRAULIC DIAGRAM Of ASPIROTRONIC LE WITH PUFFER WITH FIRST PRIORITY TO HEATING SYSTEM**

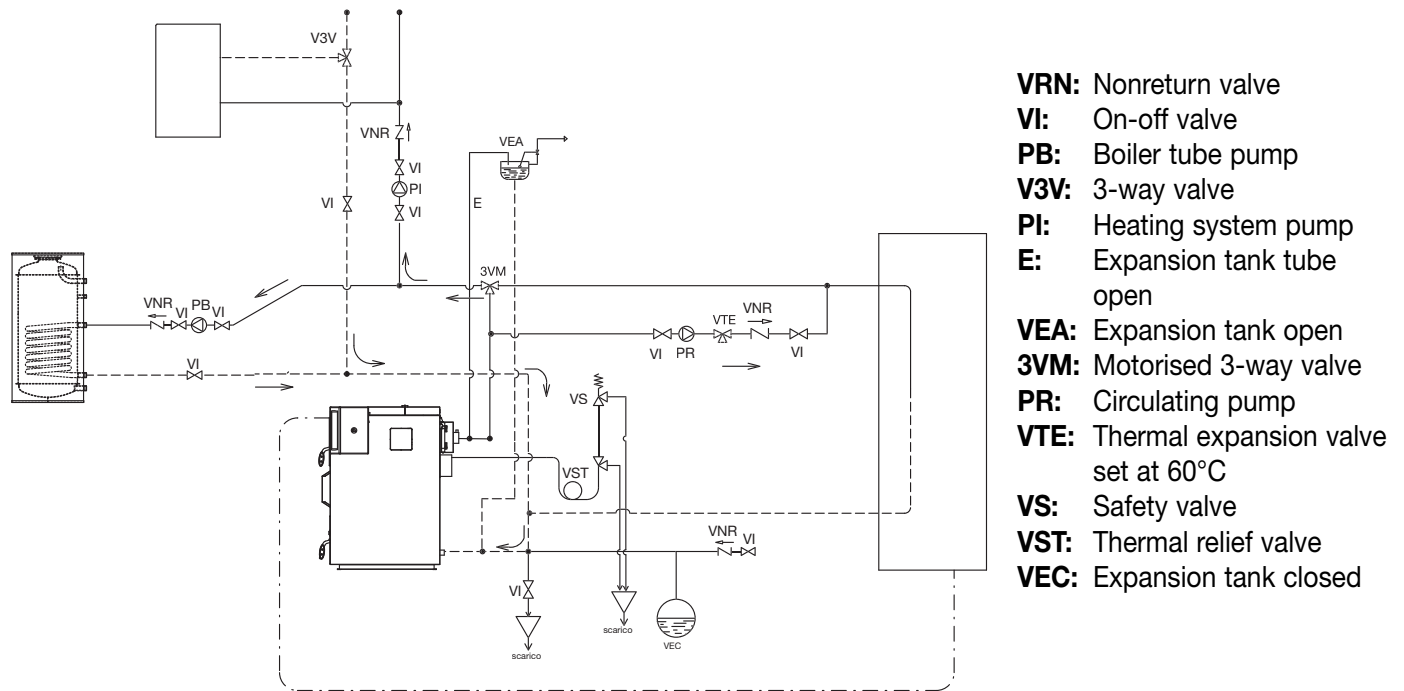

- VRN:** Nonreturn valve
- VI:** On-off valve
- PB:** Boiler tube pump
- V3V:** 3-way valve
- PI:** Heating system pump
- E:** Expansion tank tube open
- VEA:** Expansion tank open
- 3VM:** Motorised 3-way valve
- PR:** Circulating pump
- VTE:** Thermal expansion valve set at 60°C
- VS:** Safety valve
- VST:** Thermal relief valve
- VEC:** Expansion tank closed



**CAUTION:** For the management of the electronic panel with this type of plant contact an authorised Thermorossi service centre.

The approximate diagram shows an example of how the puffer can be installed in the plant. It operates as follows:

The plant must be equipped with 2 additional feelers installed on the puffer as well as the one already installed on the Aspirotronic panel to be inserted in the pocket on the wood-fired boiler.

**First phase:** Aspirotronic LE delivers heat to the plant: the plant circulating pump (PI) is activated according to the demands of the room temperature thermostat/s. It is enabled above 61°C if it's room temperature thermostat has a jumper installed and if the priority to water for household use is disabled (jumper terminal 1-4 of terminal board M2).

Its operation is similar to the plant illustrated in the diagram in paragraph 4.15.

**Second phase:** If the boiler exceeds a temperature of, for example, 75°C (adjustable), we can deduce that the temperature was reached. The pump (PR) will begin to operate above this level and start to transfer heat from the Aspirotronic LE to the inertial puffer. This situation will continue until the fuel is finished. If, during operation the temperature of the Aspirotronic LE drops below the temperature of the puffer the pump (PR) will deactivate in order to prevent the puffer from dispersing heat.

**Third phase:** when the fuel load is finished the wood-fired generator will be cut off by means of the 3-way valve 3VM, the hot water will be taken directly from the puffer. The valve will switch over as soon as the wood-fired boiler temperature drops below 55°C and then after 30 minutes. The pump PI shall be therefore enabled to operate above 40°C and shut down at 38°C: it will not be necessary to respect the activation threshold of the plant pump (PI) of 61°C in order to shut down the plant wood-fired boiler.

Fourth phase: when the pump stops below 38°C it will be possible to activate a traditional gas and/or diesel oil boiler. In this case it will be necessary to use the gas/diesel oil burner terminal as a signal activation.

## 5. USE OF THE BOILER

### 5.1 STARTING THE ASPIROMECC LE BOILER

Arrange roughly cut pieces of dry wood (D. 3-4cm) on the central part of the burner; then place thinner wood on top of this, lastly place a fair amount of newspaper on top of this wood and light it.

Turn on (see figure in Chapter 4.9) the main switch (1), the plant circulating pump switch (3), and the suction unit switch (2).

Close the baffle plate.

A few minutes later, when the wood has started to burn, add pieces of wood of suitable length for the boiler on the fire in an ordered manner (do not cross over the pieces of wood as this creates empty spaces and results in poor combustion).

This initial phase of combustion can last several minutes.



**IMPORTANT: WHEN STOKING THE BOILER WITH WOOD THE BED OF EMBERS MUST NOT BE THICKER THAN 5 CM; THIS IS TO GUARANTEE OPTIMAL OPERATION AND EFFICIENCY.**

### 5.2 STARTING THE ASPIROTRONIC LE BOILER

Arrange roughly cut pieces of dry wood (D. 3-4cm) on the central part of the burner; then place thinner wood on top of this, lastly place a fair amount of newspaper on top of this wood and light it.

Start the fan by pressing the START button.

Close the baffle plate.

A few minutes later, when the wood has started to burn, add pieces of wood of suitable length for the boiler on the fire in an ordered manner (do not cross over the pieces of wood as this creates empty spaces and results in poor combustion).

This initial phase of combustion can last several minutes.



**IMPORTANT: WHEN STOKING THE BOILER WITH WOOD THE BED OF EMBERS MUST NOT BE THICKER THAN 5 CM; THIS IS TO GUARANTEE OPTIMAL OPERATION AND EFFICIENCY.**

### 5.3 REGULATION OF COMBUSTION AIRS IN ASPIROMECA LE AND ASPIROTRONICA LE

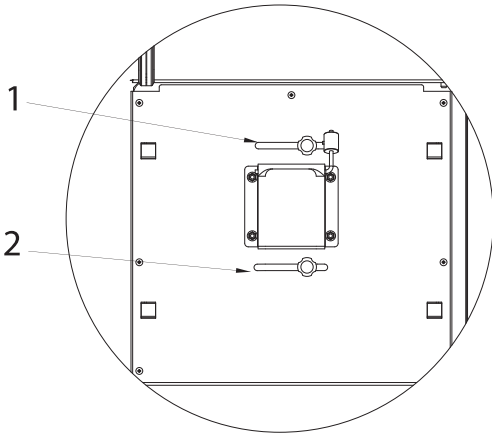

To regulate the air, first remove the guard with the writing ASPIROTRONIC on it (there is no guard on the ASPIROMECA model).

1- Act on damper 1 to regulate the intake of primary combustion air. The correct position should be 1/3 of its stroke. If the opening is bigger than there is an increase in power in the firebox.

2- Act on damper 2 to regulate the intake of secondary combustion air. The correct position should be 1/3 of its stroke; it must always be less than the primary air.

If not, the power is not supplied correctly.

The correct position for this damper guarantees optimal efficiency and low emissions. If the load of wood is placed on a bed of embers thicker than 5 cm the primary air does not flow freely. In these conditions the boiler only operates on the secondary air.

The result is a reduction of power.

### 5.4 REFUELLING WITH WOOD

#### REFUELLING THE ASPIROMECA LE BOILER WITH WOOD

- Before opening the loading door make sure that the red light on the panel is not on.

If it is on (automatic fuel finished device shuts off the fan) the boiler has to be started up again by turning the main switch off and on (the fan restarts at the maximum power).

- Open the loading door and lower the baffle plate.

- Use a riddling tool to spread out the embers and remaining wood uniformly (the height must not exceed 5 cm; if it does, the power is limited).

- Arrange the wood uniformly on the burner plate and make sure that there are as few gaps as possible between the pieces of wood.

#### REFUELLING THE ASPIROTRONICA LE BOILER WITH WOOD

- Before opening the loading door make sure that the smoke suction unit is not operating at low capacity and that it is not stopped. If it is press the H.H. button on the panel; the suction unit starts to function at maximum capacity for a time of 1 minute.

- Open the loading door and lower the baffle plate.

- Use a riddling tool to spread out the embers and remaining wood uniformly (the height must not exceed 5 cm; if it does, the power is limited).

- Arrange the wood uniformly on the burner plate and make sure that there are as few gaps as possible between the pieces of wood.

### 5.5 ADJUSTMENT OF THE COMBUSTION AIR DAMPER OPENING

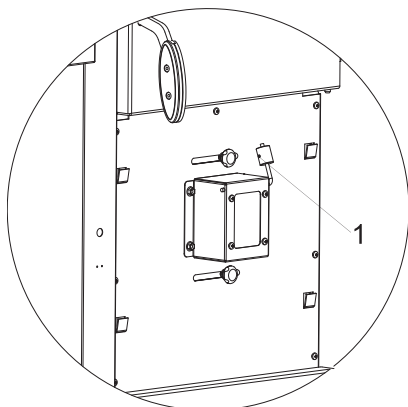

On the ASPIROMECA LE and ASPIROTRONICA LE boilers the damper must remain closed when the fan is not working.

If the flue outlet, creating an excessive draft, does not satisfy the above condition, then adjust the draft control flap by acting on the counterweight screw (1). If necessary,

bend the shaft by hand as well.

### 5.6 PRACTICAL ADVICE AND GUIDELINES

The load of wood must always be suitable for the actual technical absorption requirements of the plant: large load of wood in conditions of limited plant absorption result in long periods of unburned wood lying on top of a layer of embers. This situation encourages the distillation of the wood with the resulting formation of considerable amounts of gases and vapours which are not burned, as the suction unit which brings oxygen to the burner is not working.

The gases created from the distillation tend to condense inside the boiler and form thick layers of tar which can also drip outside and soil the boiler extensively. To avoid this situation the manufacturer recommends loading small loads during the between-season periods in order to burn all the wood in the time required to bring the plant to its working temperature.



**Important: When the fan is not working and you need to open the door to stoke the fire, always keep your hands and face away from the opening; when there is a lack of oxygen the unburned gases could light up instantly when fuelled by the fresh air entering through the opening and create a dangerous situation for the operator.**

### 5.7 WOOD FUEL



**Special attention should be given to the characteristics of the wood: like all biomass generators, good operation of the generator depends on the type of wood used as fuel and its degree of seasoning.**

- wood with one year of seasoning still has 40% moisture content and develops an average of 2000/2200 Kcal per Kg
- wood with two years of seasoning still has 25% moisture content and develops approximately 3000 Kcal per Kg
- wood with three years of seasoning still has an average of 15% moisture content and develops approximately 3500 Kcal per Kg

#### **Classification of wood quality:**

Excellent :ash, beech, maple, hornbeam, oak.

Good quality: birch, alder and acacia.

Satisfactory: linden, poplar, willow, chestnut, fir and larch.

Barely suitable: other types of resinous wood.

The wood must be cut as far as possible equal to the size of the combustion chamber in order to completely cover the base of the refractory and also to obtain a heavier load and therefore a longer duration.

The billets of wood must be placed parallel to each other in order to leave as few gaps as possible.

To express the rated power the fuel load must be placed on a bed of embers that is no thicker than 5 cm.

The maximum useful power is obtained using wood pieces having a diameter of 5/7 cm, even if larger pieces could be used.

## 6 TROUBLESHOOTING

### 6.1 TROUBLESHOOTING FOR ASPIROTRONIC LE AND ASPIROMECC LE BOILERS

<b>Difficulty with the first start up</b>	Burner blocked	Clean the burner by lifting the plate
	Moist wood or too thick	Use more seasoned and smaller pieces of wood
	No air in the room	Make a larger opening for the air
	Wood is not yet perfectly alight	Open the top door and wait for it to light completely
<b>The flame does not reverse</b>	Suction unit fan is stopped	Start the fan and check its working order
	Smoke passages obstructed	Clean with the special brush
	Secondary air too open	Close to 1/3 of the stroke
	Primary air too closed	Open to _ of the stroke
	Air box obstructed	Disassemble and clean
	Flue outlet clogged with ash	Clean
	Boiler very dirty	Clean
<b>The water in the boiler tends to overheat and boil</b>	Draft control flap open	Reduce the flue outlet draft
	The pumps are not active	Check their working order
	Thermostat bulbs or feeler	Check that the bulbs are inserted correctly in the pockets in contact with the diathermic oil
<b>Tendency to generate condensation</b>	Anticondensation thermostat faulty (ASPIROMECC)	Replace thermostat
	Boiler too big	Reduce wood load to prevent pauses
	Smoke condensation along the flue outlet	Insulate flue outlet
	Low temperature in boiler	Connect pumps to panel
<b>The boiler does not heat up sufficiently</b>	Wood pieces are too big	Split wood into smaller sized pieces
	Ash pan is not resting on the bottom	Push the pan up against the internal wall of the boiler

## 7 CLEANING AND MAINTENANCE

### 7.1 CLEANING AND MAINTAINING ASPIROTRONIC LE AND ASPIROMECC LE BOILERS



FIGURA B

FIGURA A  
(LE 35-54-73-102)FIGURA C  
(LE 24)

**The LE series boilers must be cleaned in accordance with the following time schedule:**

**EVERY 3 days** remove all ash from the compartment using the special tool (figure B) to de-ash the cast iron pan. The compartment, consisting of 3 parts made from refractory cast iron, collects the ash and dust which drops from the burner.

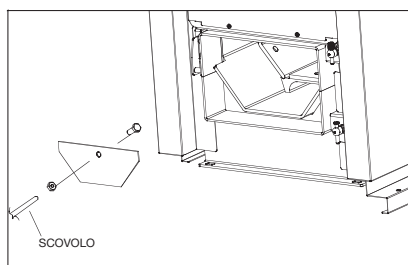
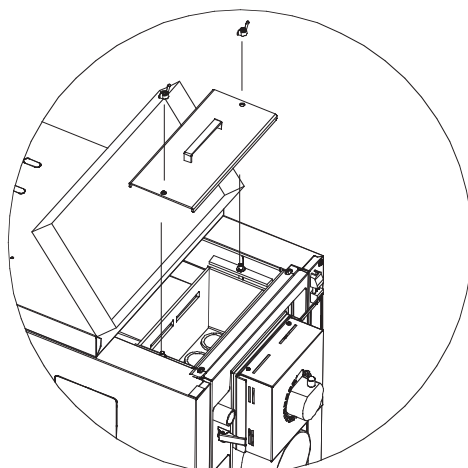
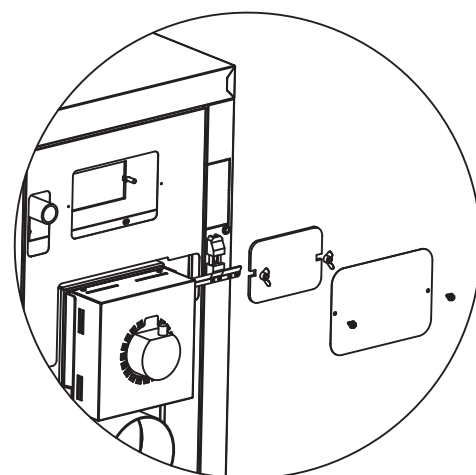
**EVERY 7 days** clean the burner completely; any small cracks appearing in the refractory bricks do not affect the excellent operation of the boiler in any way whatsoever.

**EVERY WEEK OR IS NECESSARY** inspect and clean the blade of the smoke suction unit (see figure para. 4.11). The dust accumulated by the blades must be removed; good wood fuel creates very little dust on the fan blades.

In ASPIROTRONIC LE 22 remove the suction unit to clean the back hood; use the brush to clean the internal surface (residues always accumulate at the bottom of the hood); with the same frequency clean the union tee at the base of the smoke discharge tube.

**EVERY MONTH** clean the tube bundle at the back of the boiler using the special steel tool provided (figure a).

**THE END OF EVERY SEASON** clean the entire boiler and flue outlet.

### 7.2 CLEANING AND MAINTAINING THE EURA BOILERS

**The EURA gas-diesel oil boiler does not require frequent cleaning like the wood fired boiler, however good maintenance and cleaning of the tube bundle before the winter season will keep it perfectly efficient.**

**Simply open the front door, on which the burner is installed, and the back door.**

**Remove the steel cylinder, the turbulators and clean thoroughly.**

It is advisable to have the burner calibration and its combustion checked regularly by an expert burner technician.

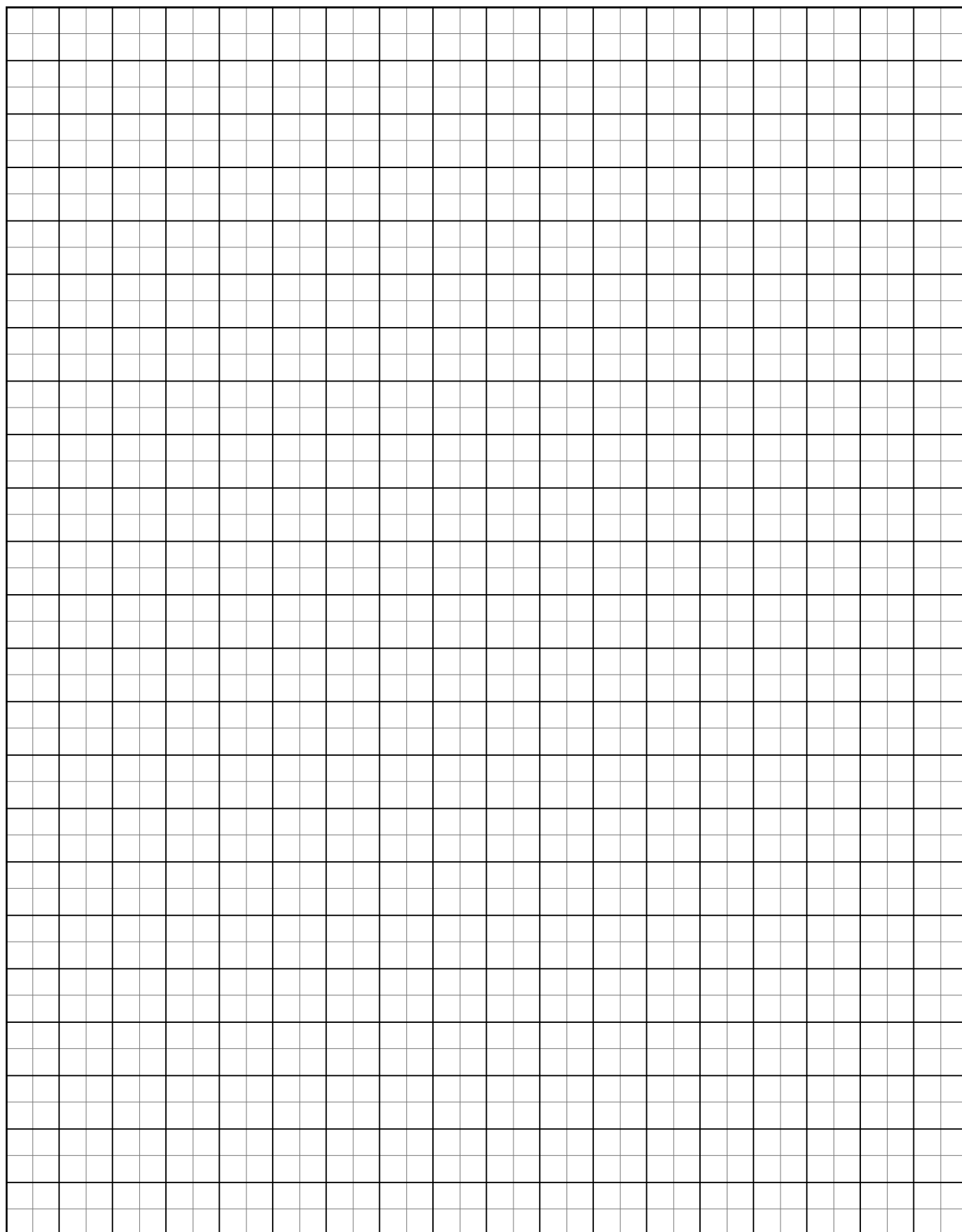



36011 Arsiero (VI) Italy - Via Grumolo, 4 - Z.I. - Tel. 0445. 741310 (5 l.r.a.) - Fax 0445. 741657  
Web Site: [www.thermorossi.com](http://www.thermorossi.com) - E-mail: [thermorossi@keycomm.it](mailto:thermorossi@keycomm.it)