



EURO TRIC F Free Standing

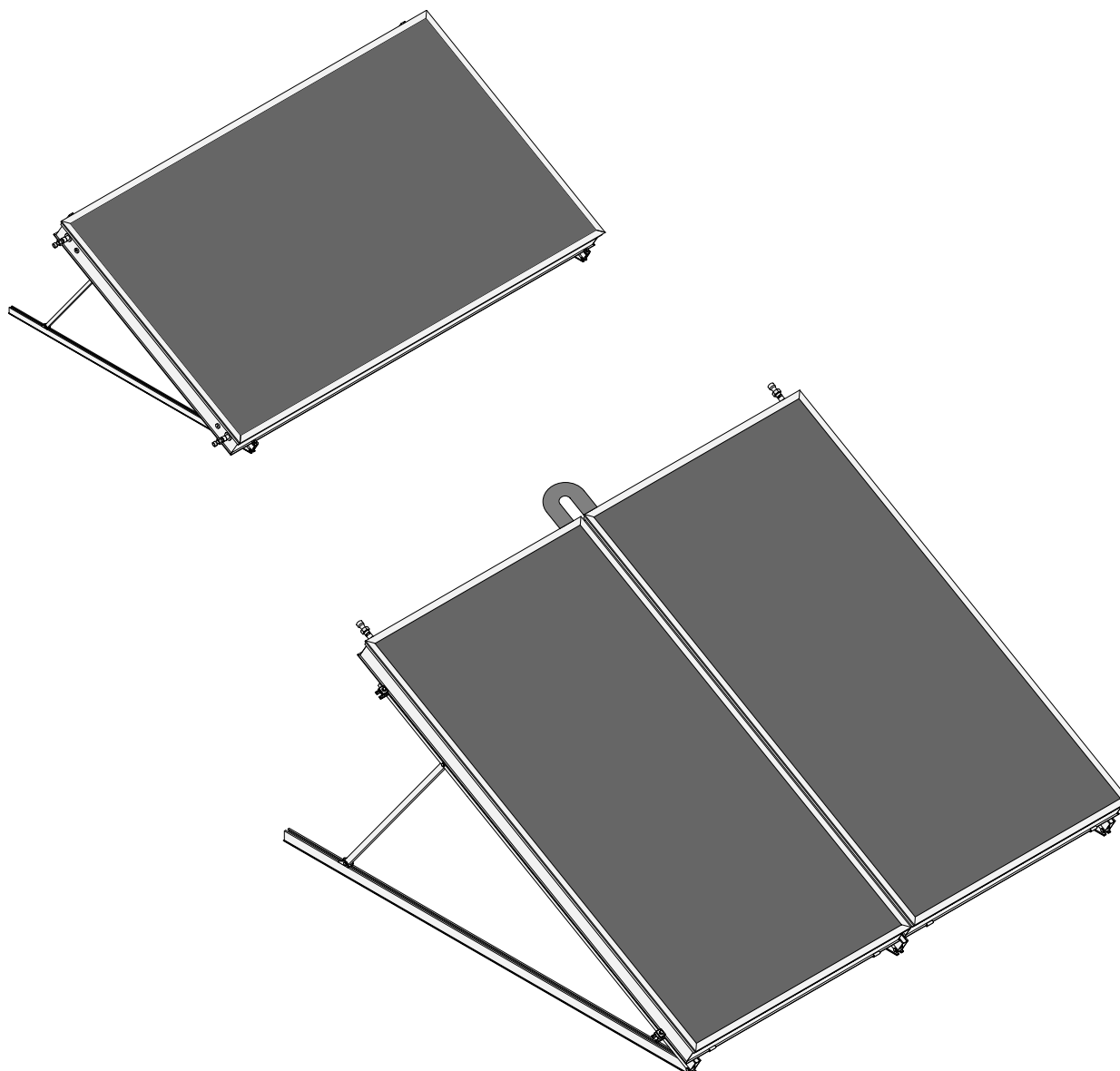

Figure 1 Horizontal and vertical free standing setup

Content

1. General Safety Notes	2
2. Scope of Supply	5
3. Installation of Racking Triangles.	8
4. Horizontal Collector Installation	15
5. Vertical Collector Installation	16
6. Sensor Installation	19
7. Collector Connections.	19
8. Accessories	20

Installation instructions valid for these collectors:
EURO L20, EURO C20, EURO C30, EURO C22,
EURO L22, EURO C32



1. General Safety Notes

1.1 Symbols

The following symbols are used throughout these instructions and must be adhered to:



DANGER of possibly serious personal injury



WARNING against material damage.



NOTE as additional information

1.2 Norms and Regulations

The standards and regulations applicable at the installation location must be adhered to. In absence of other regulations we recommend to follow the following norms:

Thermal Solar Systems and Components

- EN 12976 and EN V 12977

Electrical Work, Potential Equalization, Lightning Protection

- DIN EN 62305
- VDE 0185 part 305
- DIN VDE 0100 part 540
- VDE 190
- DIN 18382

(Other regulations may apply, depending on your region, country or territory.)

Especially the pipes in the lower parts of the building must be connected electrically conductive, conforming to standards. The collector installation must be professionally integrated with an existing or new lightning protection system.

Snow and Wind Loads

Comply with local regulations and norms related to snow and wind loads, within the EU to EN 1991-1-4 (Wind Actions) and EN 1991-1-3 (Snow Loads). If you have questions related to structural conditions and planning, please contact our technical department for information. We offer comprehensive planning support on a project base.

Work on Roofs

Make sure to observe country and territory regulations related to roof works and roof sealing standards as well as professional codes for plumbing work.

The installation process must reflect the on-site conditions as well as applicable rules, regulations and accident prevention procedures. Basic accident prevention principles are shown in figure 5. Installers must be qualified and - where applicable - licensed to work on roofs.

1.3 Qualification of the Installer

Setup, installation and proper commissioning of the solar installation must be carried out by authorized professionals. Non-compliance renders the warranty void.

1.4 Intended Use and Application

Proper Outdoor Storage of Collectors

Remove protective film and lay down collectors with glass pane up. Avoid direct ground contact (e.g. underlay square timber). Avoid scratches on glass panes by using spacers between collectors (e.g. wooden laths). When leaning collectors against walls or similar, use a minimum inclination of 15° and apply spacers. Do not use cardboard as underliner. If incorrectly stored, humidity can enter the collectors through the air vents. Storing collectors in foil package can damage the glass surface (see figure 2).



Scope and Limitations of Application

The collector is intended for the application in solar thermal installations for hot water preparation and space heating support. As operating mediums water (attention - risk of freezing!) or an appropriate water-glycol mixture can be used in a closed circuit. Operational conditions under-running the dew point within the collector for prolonged periods are not permitted! This can occur for example, when collectors are integrated in the brine circuit of a heat pump.



Overheat Protection

For roof heating centrals and when 4 or more EURO collectors with anti reflective glass are installed vertically, the "Technical Information Solar Thermal Systems - Setup, Commissioning and Maintenance" must be followed to avoid damage to the solar circuit.



Preventing frost Damage

After pressure testing and flushing, collectors cannot be completely emptied. Make sure that no pure water remains in collector during risk of frost!



Empty Collector on Roof

After being installed on the roof, unfilled collectors should not be exposed to the sun for more than a few days. Otherwise thermal stress on gaskets can result in damage. Alternatively postpone the installation of gaskets to just before filling the solar circuit.



Maintenance

For maintenance notes and additional information about setup and operation of the collector field, please refer to the technical information "Solar Thermal Systems".

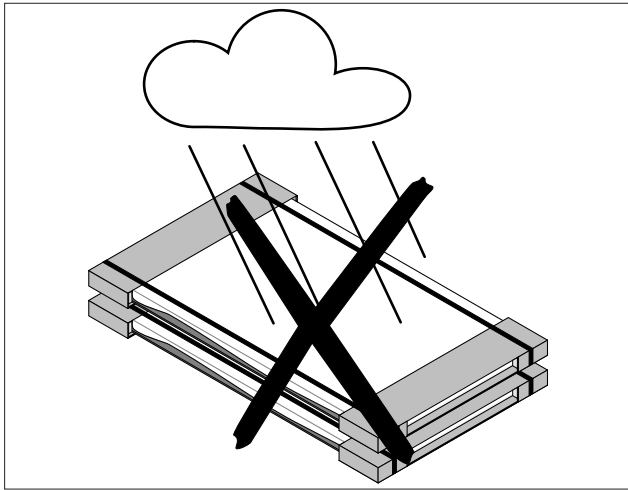

Figure 2 Do not expose collector covered with protective film to rain.

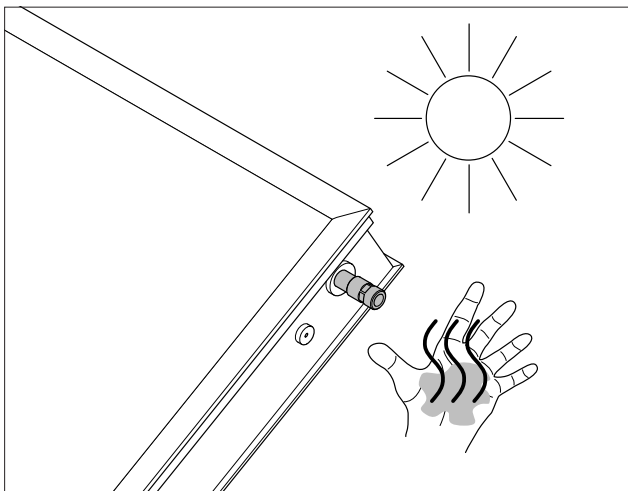

Figure 3 Collector connections heat up during solar irradiation.

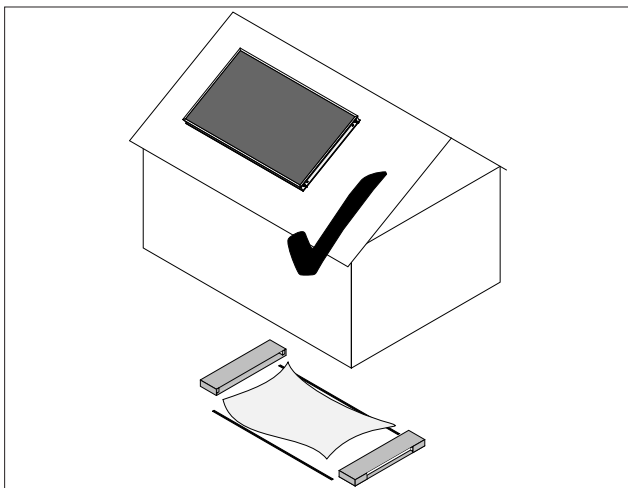

Figure 4 Remove glass protection film before installing collector!

1.5 Pre Installation Notes

- Risk of burns at collector connections as soon as uncovered collector is exposed to the sun (figure 3).
- Danger of open injuries when working with sharp edged metal sheets and components!
- Remove protective plastic caps from connections before collector is exposed to the sun. Risk of melting and damage to absorber!
- Remove glass protection PE-LD film before commencing installation work! (figure 4).



1.6 Recycling Note

At the end of the long operational lifetime, the valuable materials of the installation should be recycled in an environmentally sound manner. If recycling is not possible, Wagner & Co will take the scrap material back.

You can find additional information in the "Partner Area" of our website at <http://www.wagner-solar.com>

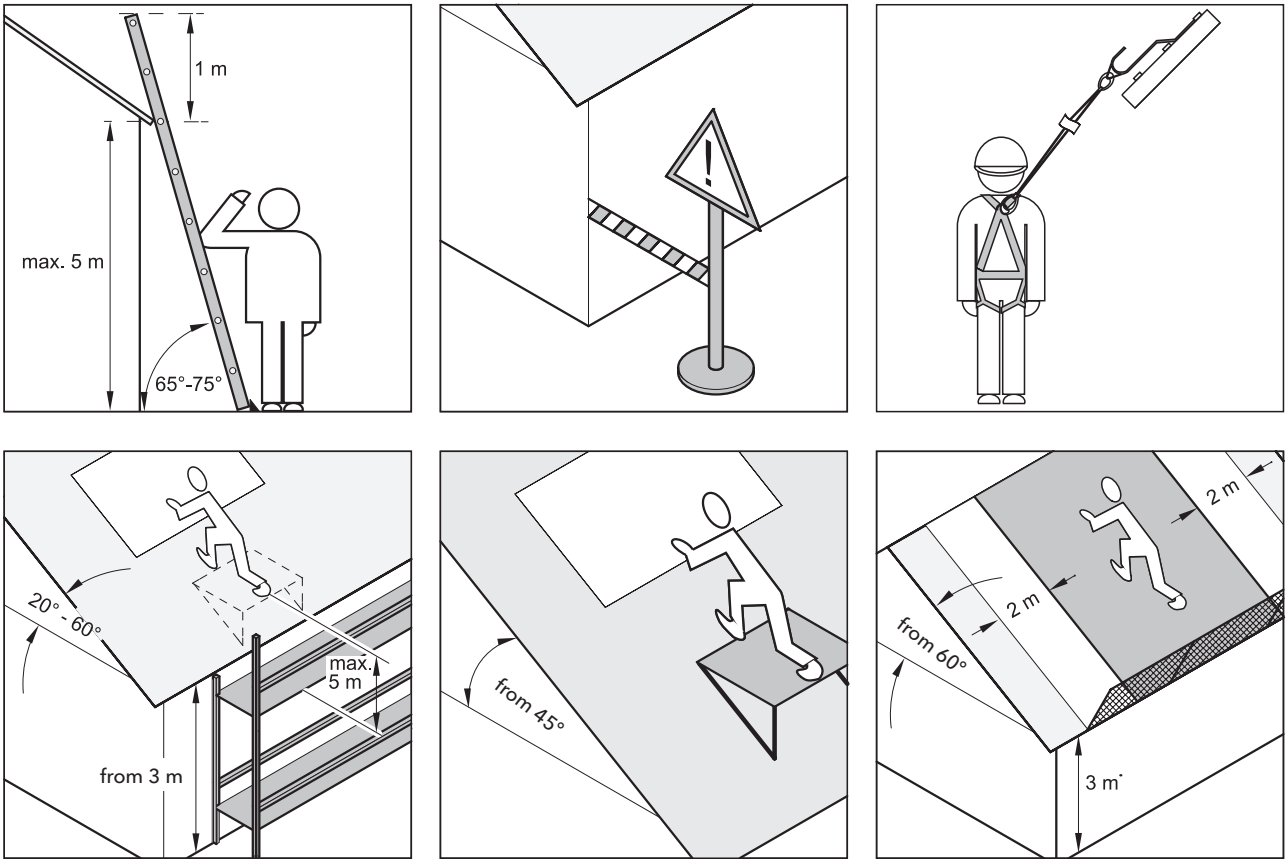

Figure 5 Accident prevention guidelines for work on roofs.

2. Scope of Supply

2.1 Horizontal

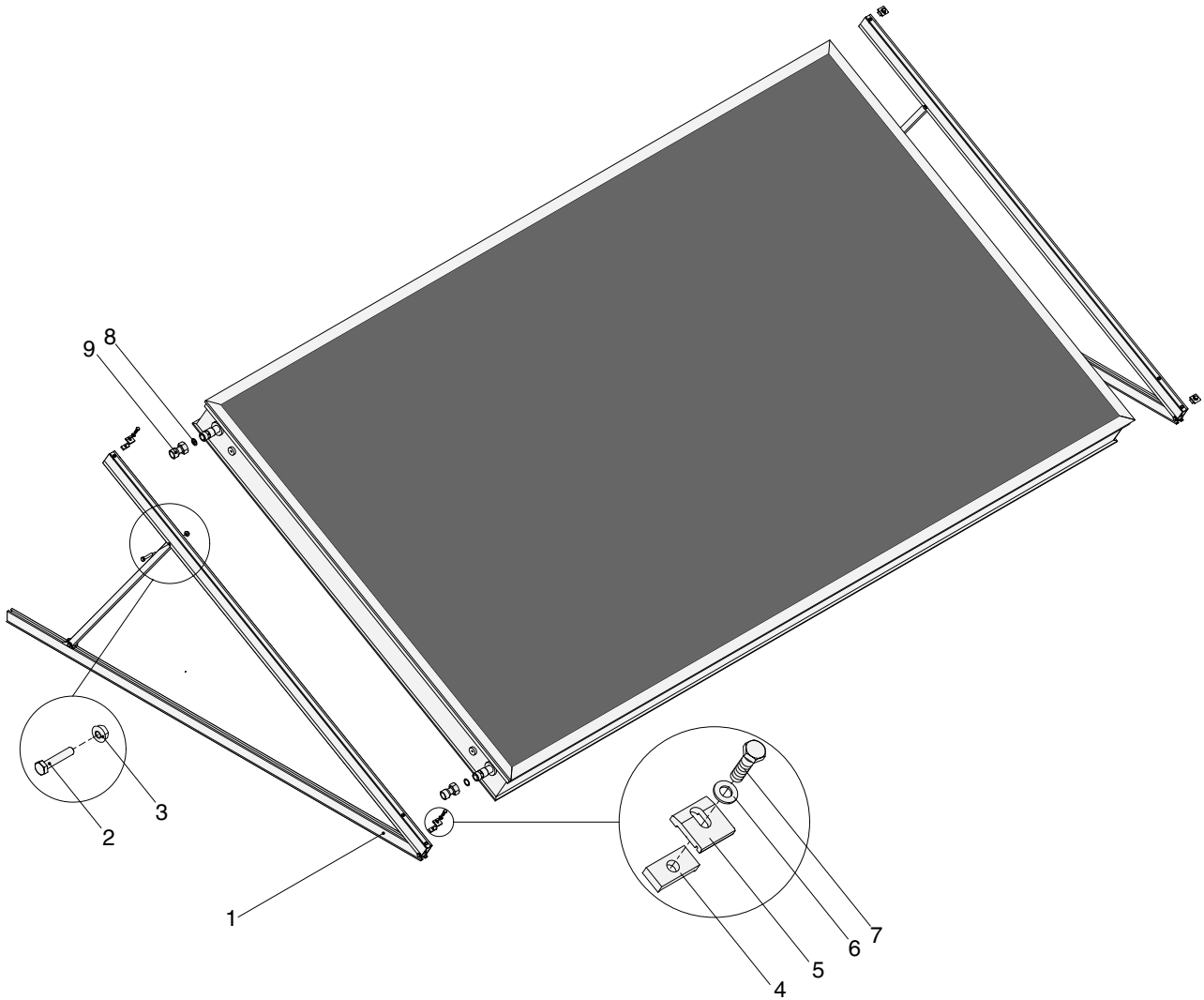

Figure 6 Basic Set, horizontal, free-standing installation (collector not included in delivery)

Table 1 Figure no.	Components: Basic Set, Horizontal	Quantity
1	Pre-assembled racking triangle	2
2	Hexagonal screw M8 x 40	2
3	Nut M8 interlocked	2
4	Collector clamp - lower side	4
5	Collector clamp - top	4
6	Washer Ø 8.4	4
7	Hexagonal screw M8 x 30	4
8	Gasket ½"	2
9	Interconnection (screw to solder) ½" - 18 mm	2

2.2 Vertical

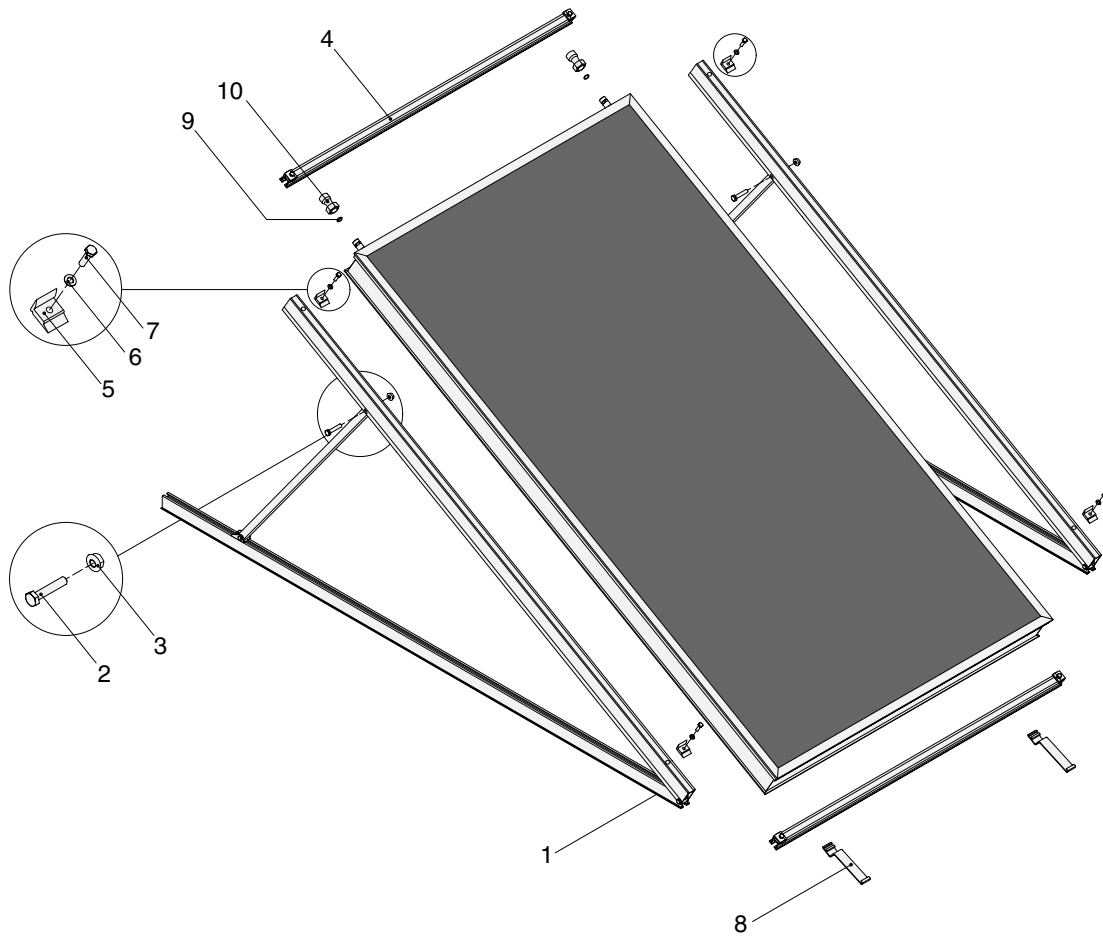

Figure 7 Basic Set, vertical, free-standing installation (collector not included in delivery)

Table 2 Figure no.	Components: Basic Set, Vertical	Quantity
1	Pre-assembled racking triangle	2
2	Hexagonal screw M8 x 40	2
3	Nut M8 interlocked	2
4	Collector rail 1257 mm (EURO L20, C20, C30) or 1202 mm (EURO L22, C22, C32) incl. 2 collector clamps	2
5	Clamping angle	4
6	Washer Ø 8,4	4
7	Hexagonal screw M8 x 30	4
8	Collector holder	2
9	Gasket ½"	2
10	Interconnection (screw to solder) ½" - 18 mm	2

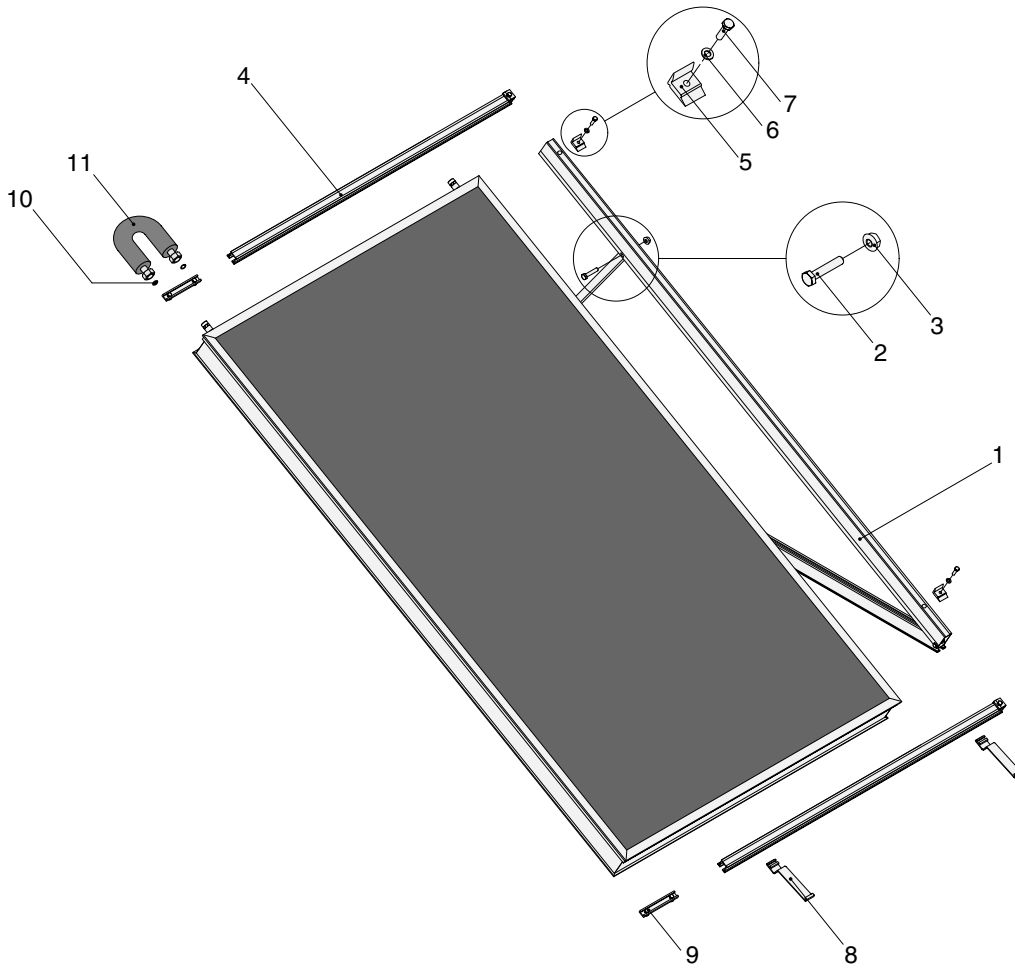

Figure 8 Extension Set, vertical, free-standing installation (collector not included in delivery)

Table 3 Figure no.	Components: Extension Set, Vertical	Quantity
1	Pre-assembled racking triangle	1
2	Hexagonal screw M8 x 40	1
3	Nut M8 interlocked	1
4	Collector rail 1223 mm (EURO L20, C20, C30) or 1168 mm (EURO L22, C22, C32) incl. 1 collector clamp	2
5	Clamping angle	2
6	Washer Ø 8.4	2
7	Hexagonal screw M8 x 30	2
8	Collector holder	2
9	Rail connector	2
10	Gasket ½"	2
11	Collector connection hose, 250 mm length	1

3. Installation of the Racking Triangles

3.1 Possible Inclination Angles

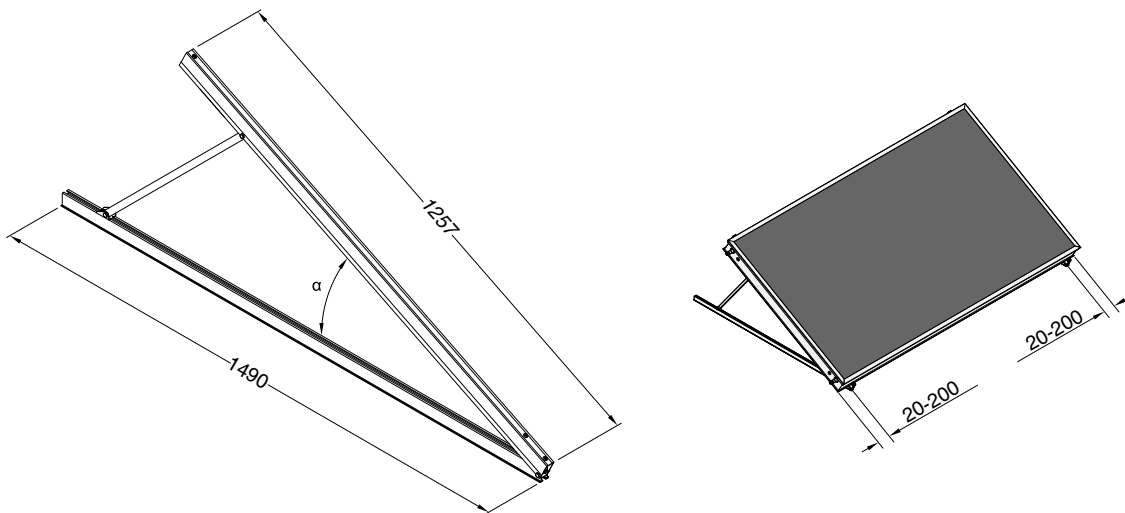

Figure 9 EURO TRIC F horizontal for 35° - 50°

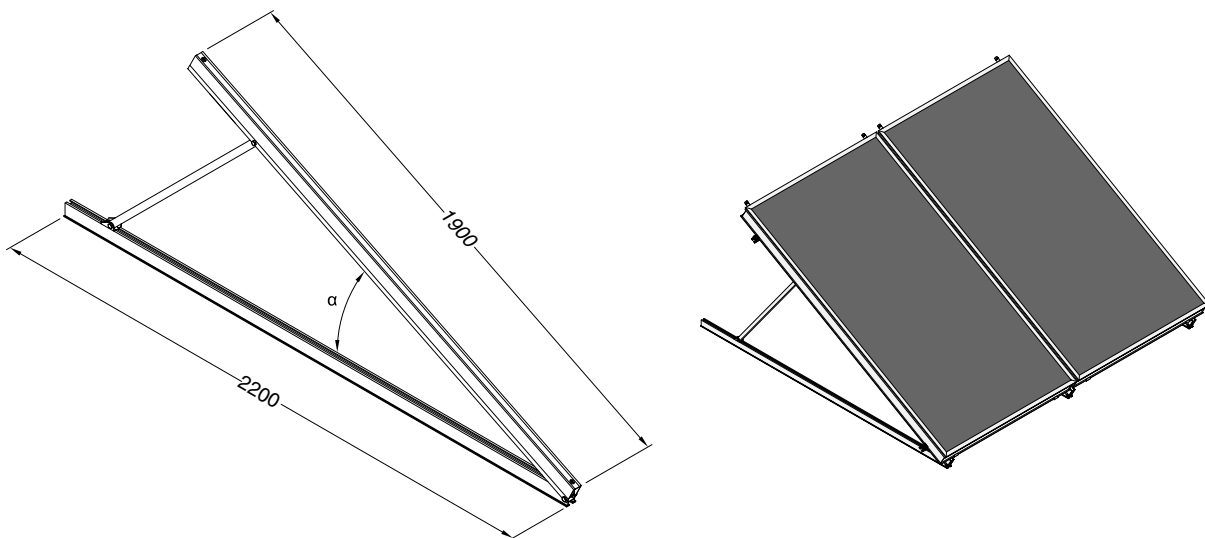

Figure 10 EURO TRIC F vertical for 37° - 50°

3.2 Setting up the Racking Triangle

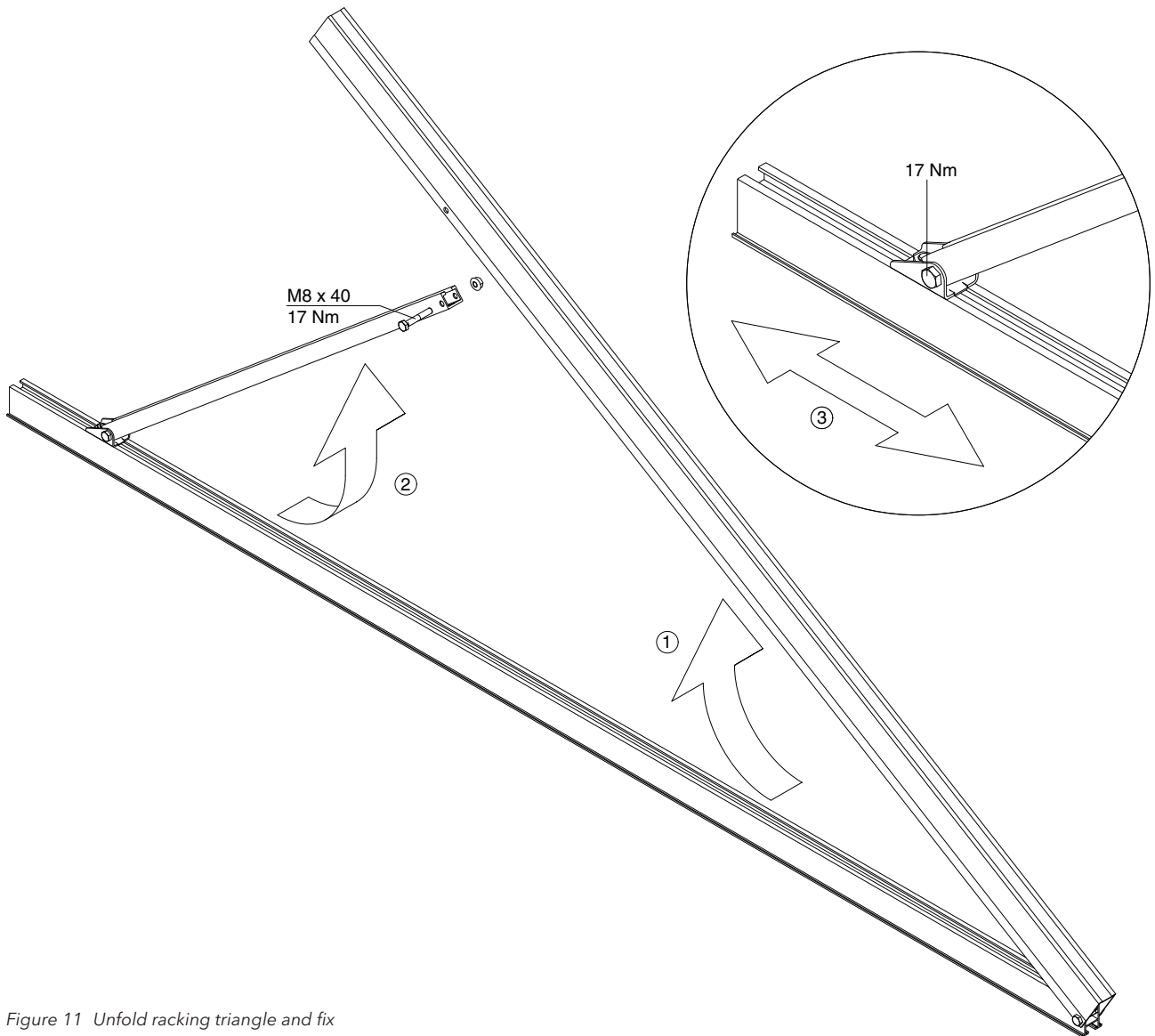

Figure 11 Unfold racking triangle and fix

3.3 Determining the Collector Inclination α

Table 4	Collector Type	α [°]	A [mm]	B [mm]
EURO TRIC F horizontal 35° - 50°	All EURO-collectors	35°	863	10
		40°	940	147
		45°	1009	311
		50°	1070	521
EURO TRIC F vertical 37° - 50°	EURO L20, EURO C20 and EURO C30	37°	1471	0
		40°	1553	153
		45°	1679	458
		50°	1782	920
	EURO L22, EURO C22 and EURO C32	37°	1338	0
		40°	1410	153
		45°	1522	458
		50°	1619	920

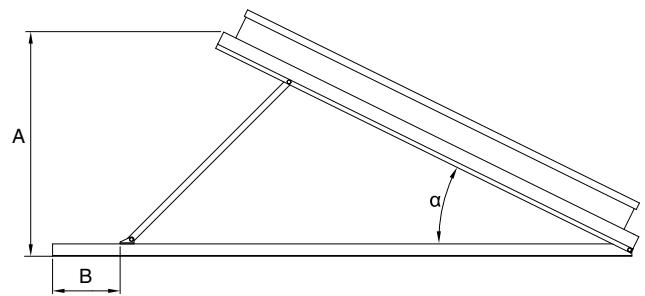

Figure 12 Collector inclination and setup dimensions

3.4 Positions of the Ground Fixations

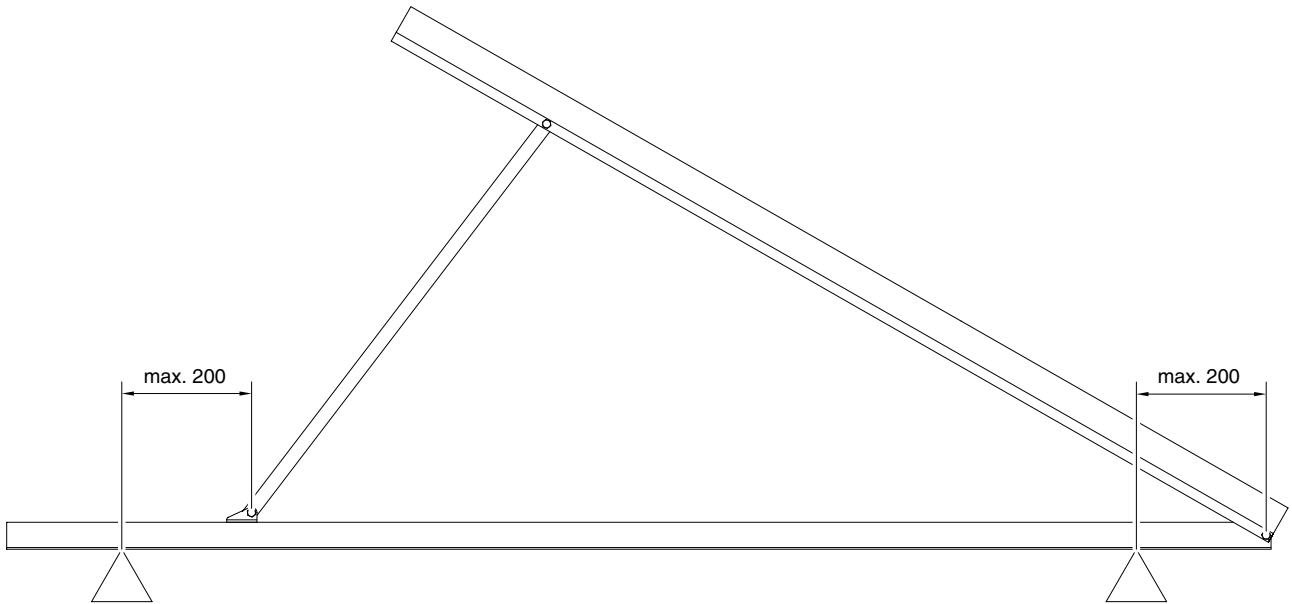

Figure 13 Max. distance from ground fixations (mm)

i The number of clamping angles required for fixing the racking triangles depends on the type of surface. If unsure, please contact our technical support for more information.

3.5 Installation on Steel Beams

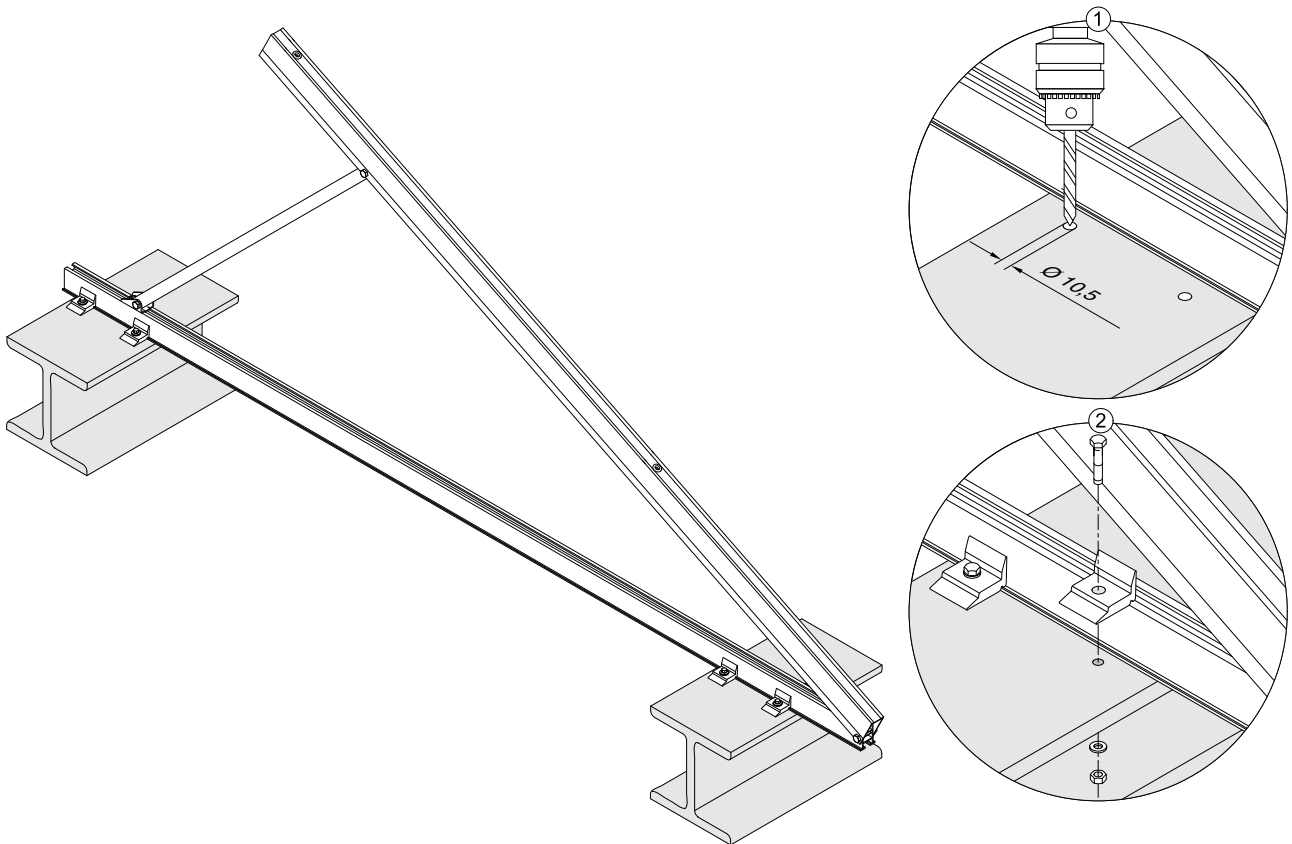

Figure 14 Fixing the racking triangles on steel beams

3.6 Installation on Concrete Slabs

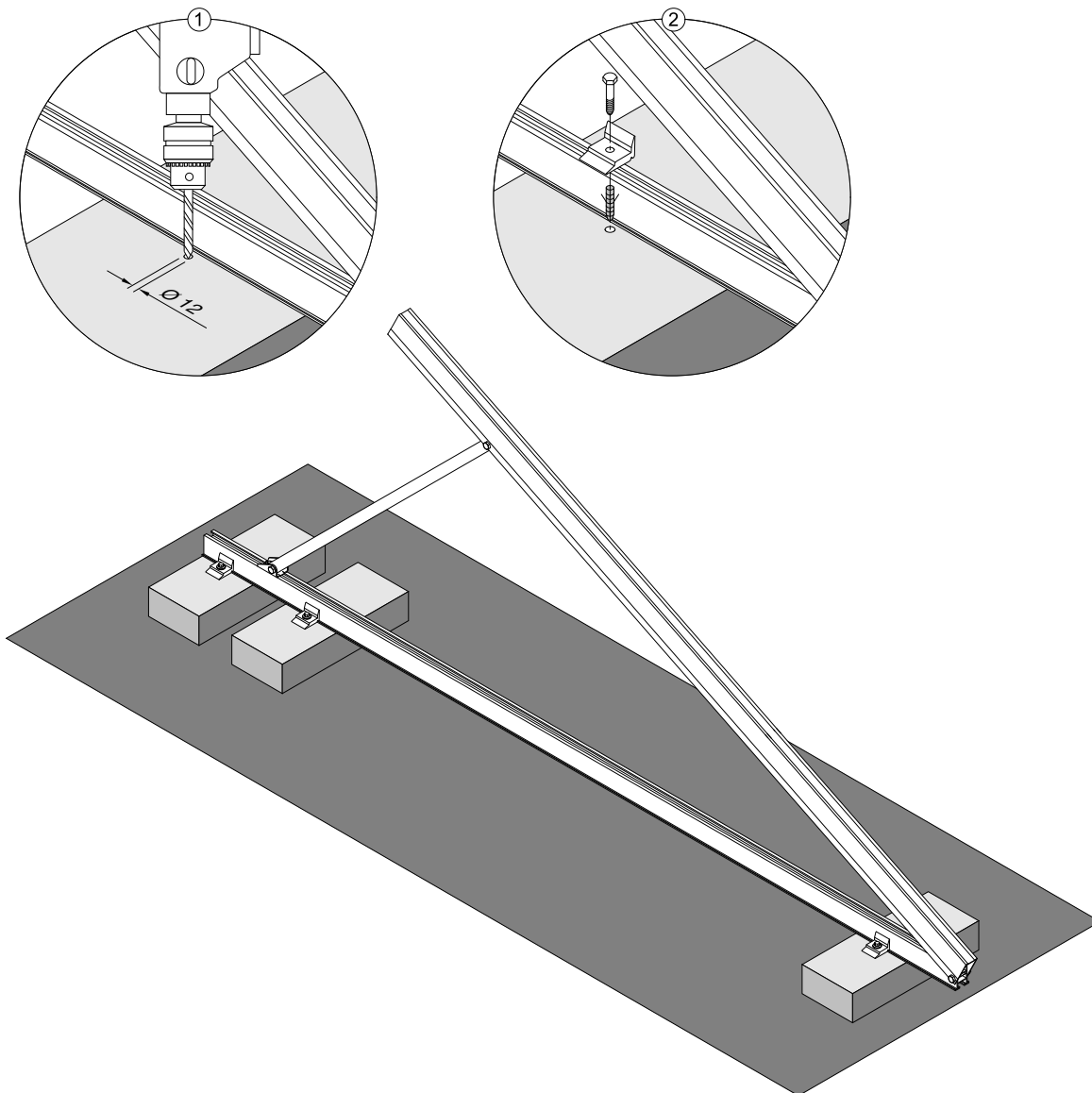

Figure 15 Fixing the racking triangles on concrete slabs placed on protective underlay.

3.7 Installation on Gravel Board Set

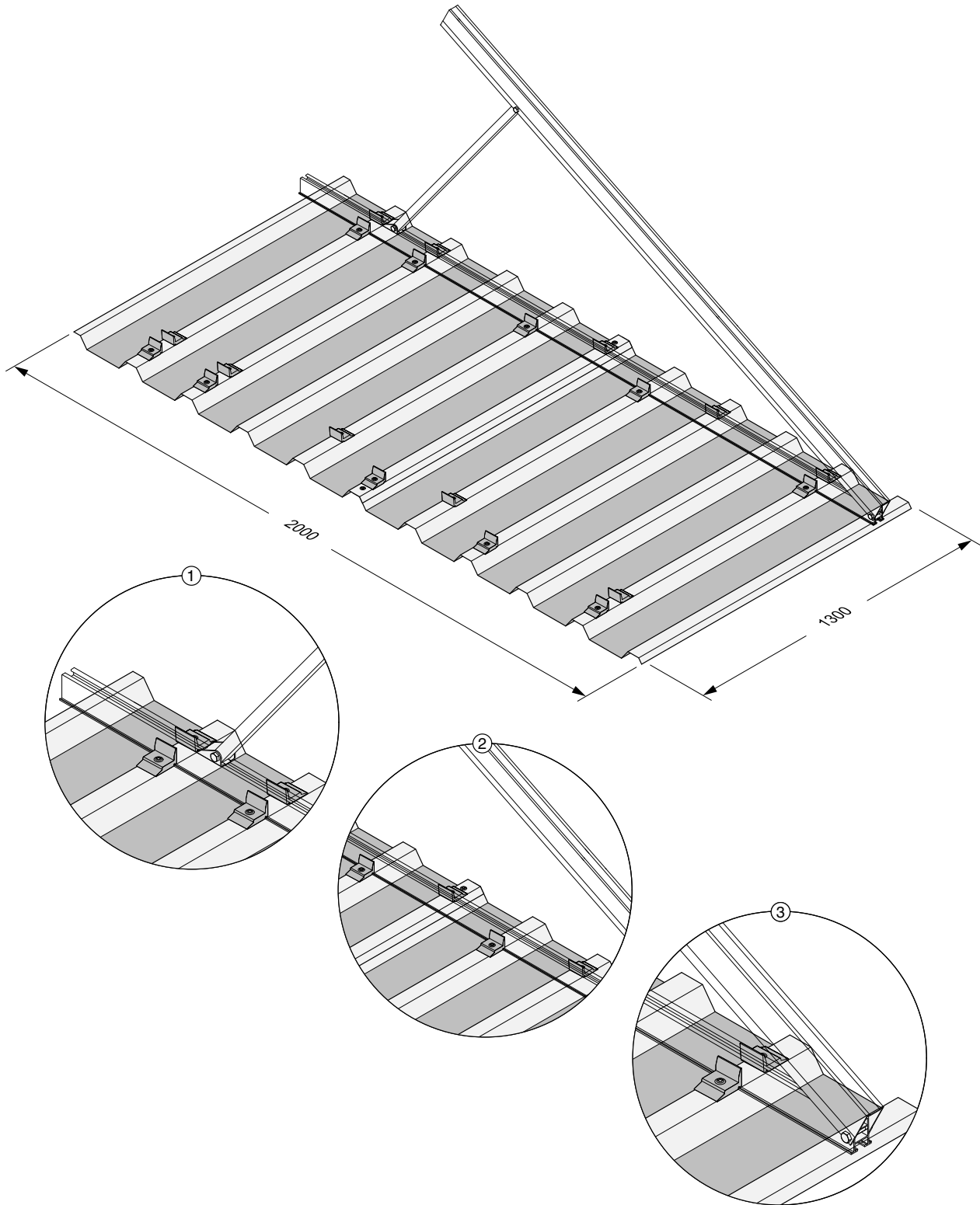

Figure 16 Gravel board basic set for vertical installation (prod. no. 192 020 75). At the supporting profile of the triangle use 4 clamping angles to encompass the ground rail on both sides (magnifying glass 1). At the front (magnifying glass 2) use one angle on each side.

 Provide protective underlay to avoid damage to roofing!

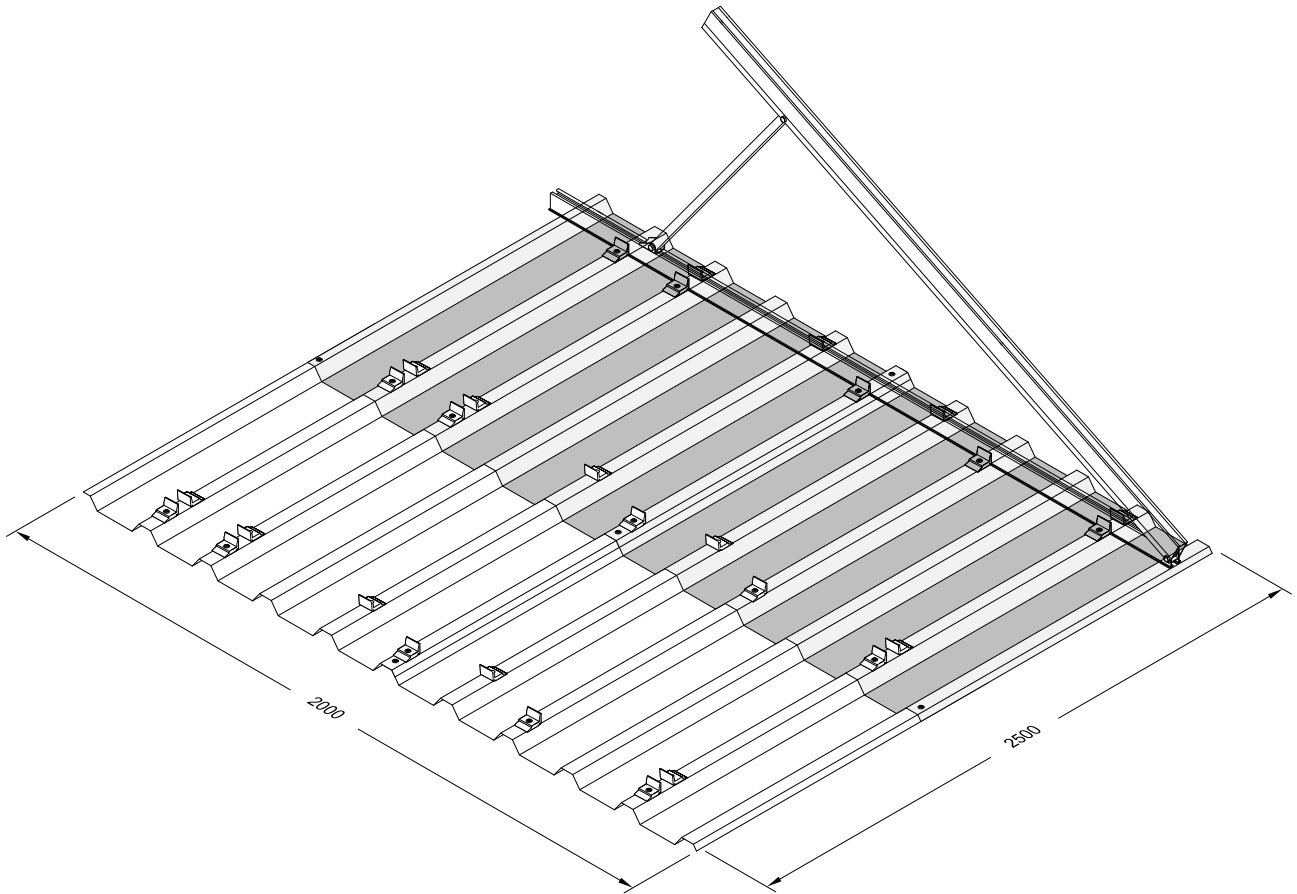

Figure 17 Gravel board basic and extension sets for vertical installation (prod. no. 192 020 76)

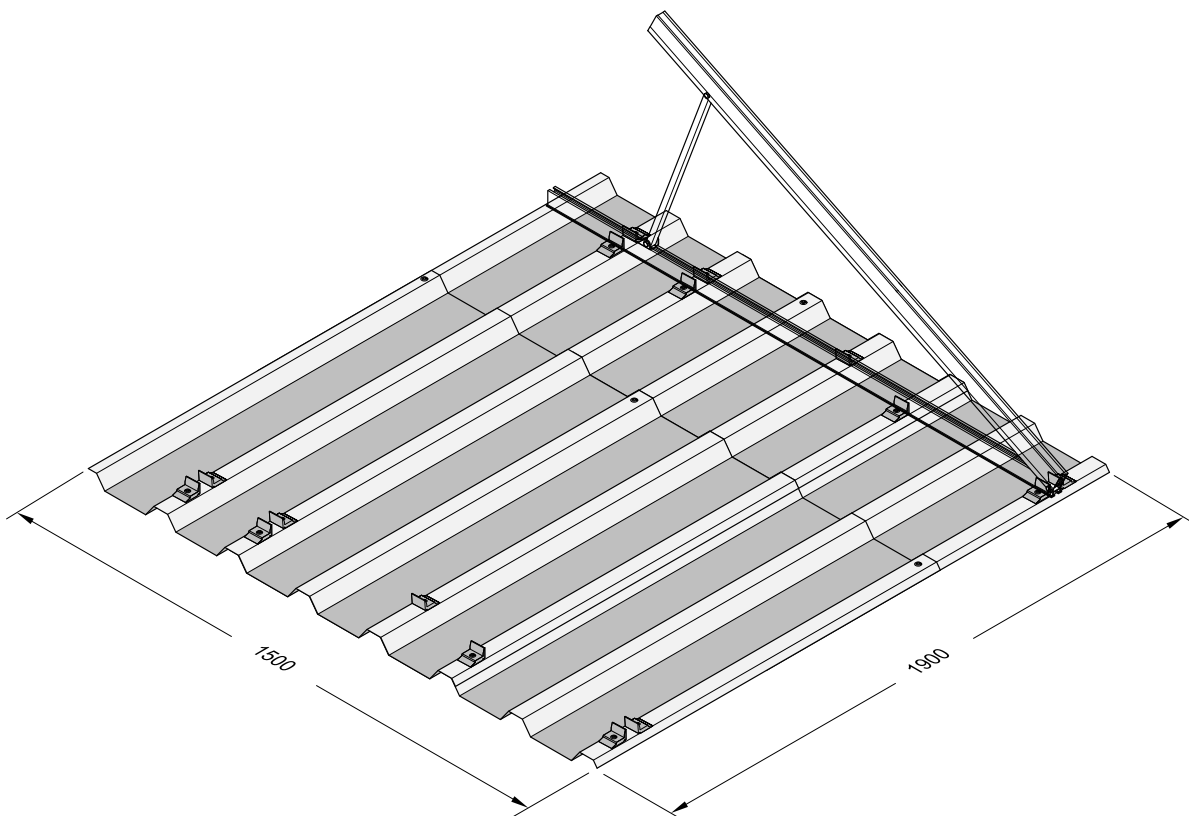

Figure 18 Gravel board set for horizontal installation (prod. no. 192 020 74)

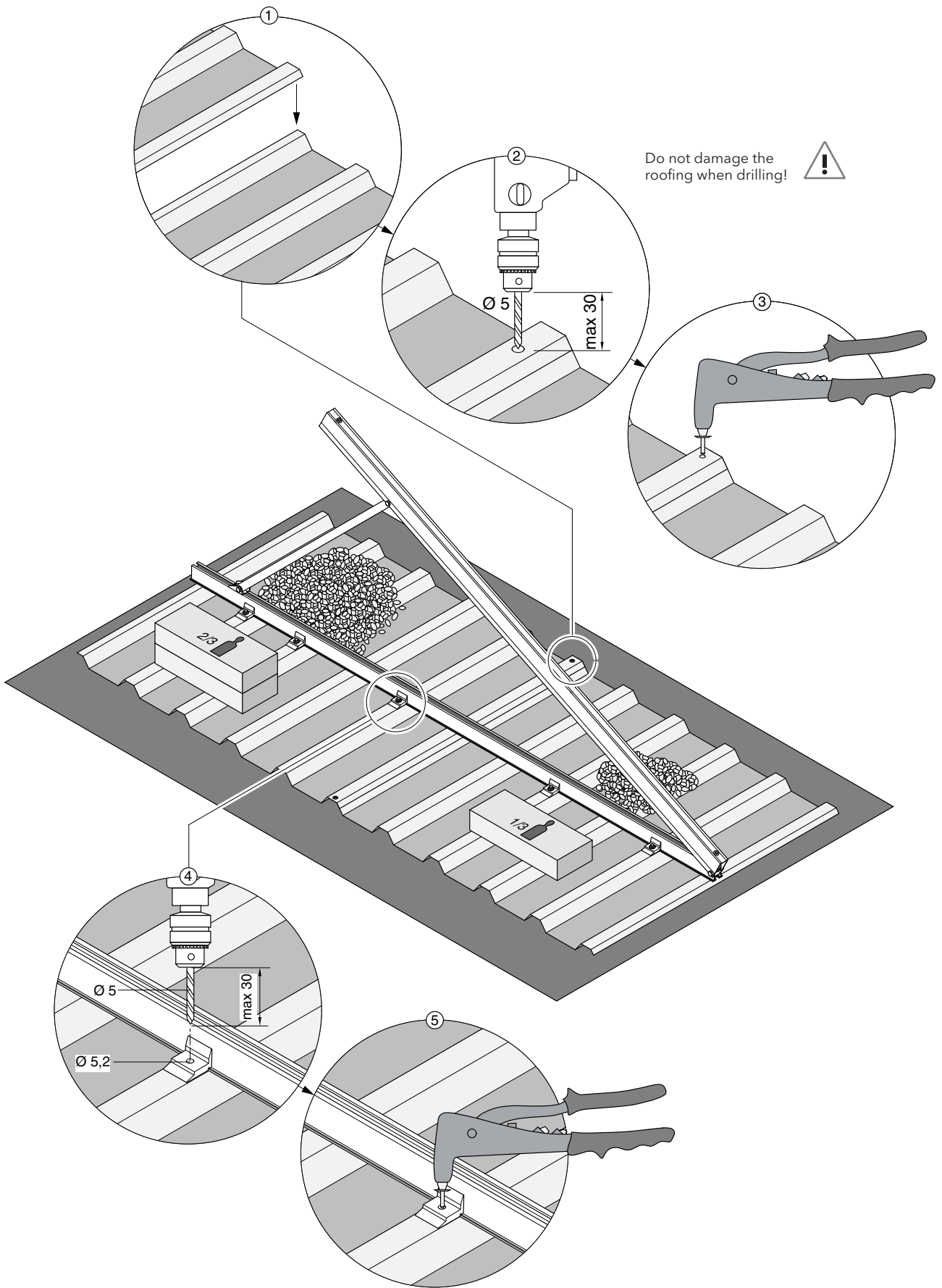
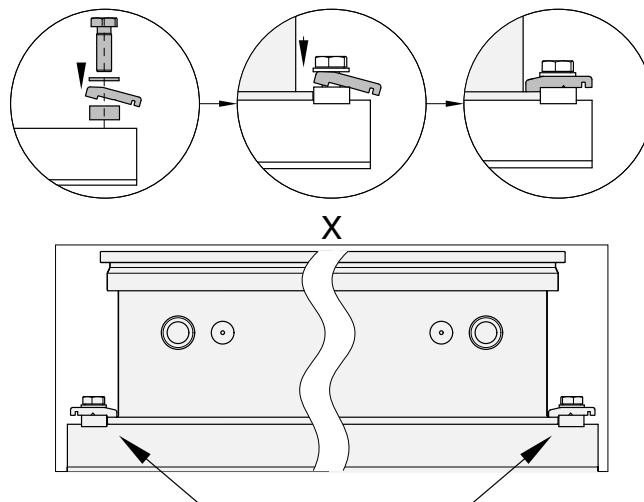
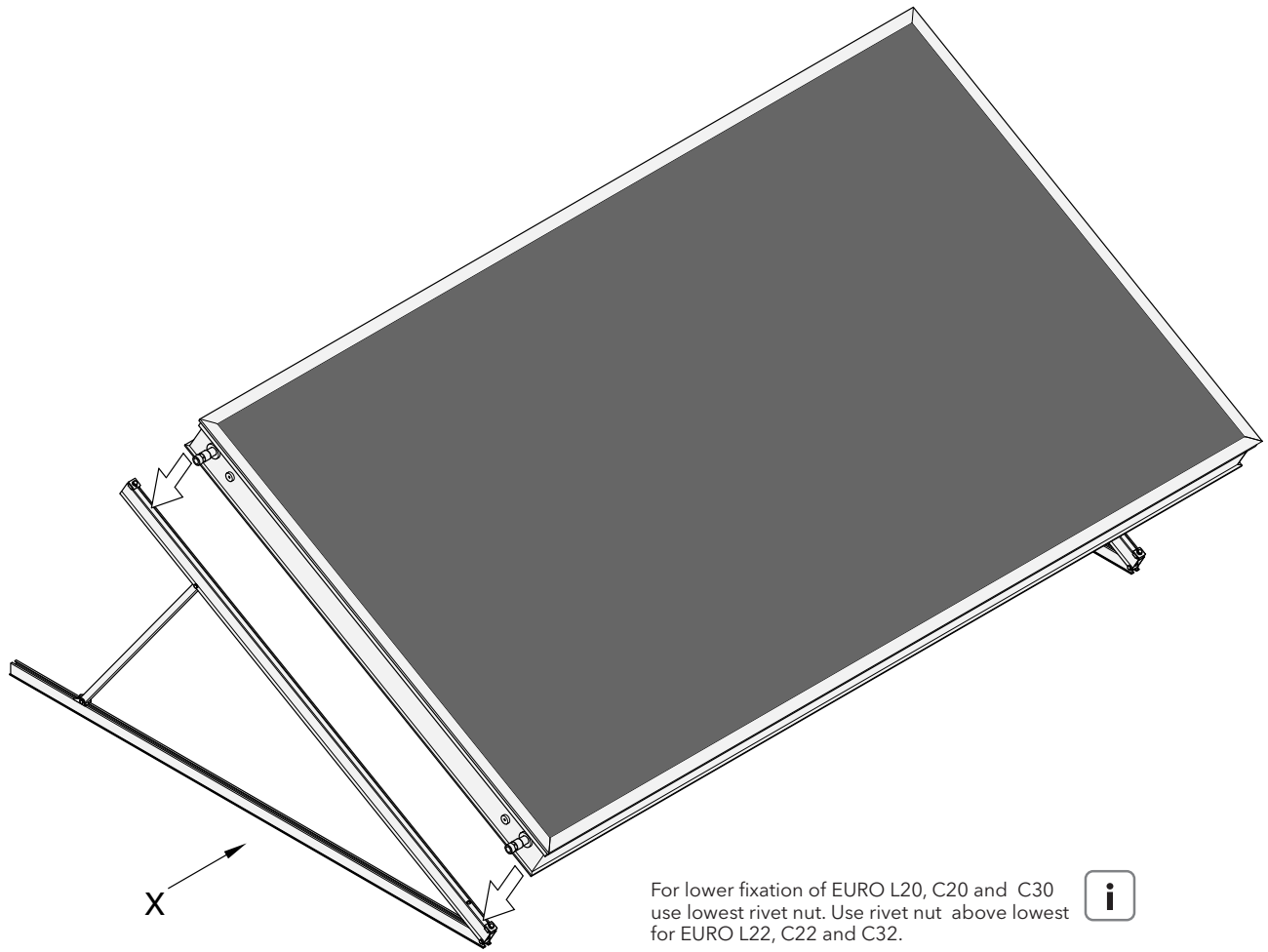

Figure 19 Fixing the racking triangles on gravel boards.

4. Horizontal Collector Installation



Loosely pre-install the collector clamps and then place collector. Finally push collector clamps to collector and tighten. Incorrectly positioned collector clamps may result in insufficient stability! !

Figure 20 Connecting collector and racking triangles

5. Vertical Collector Installation

5.1 Installation of the Collector Supporting Rails

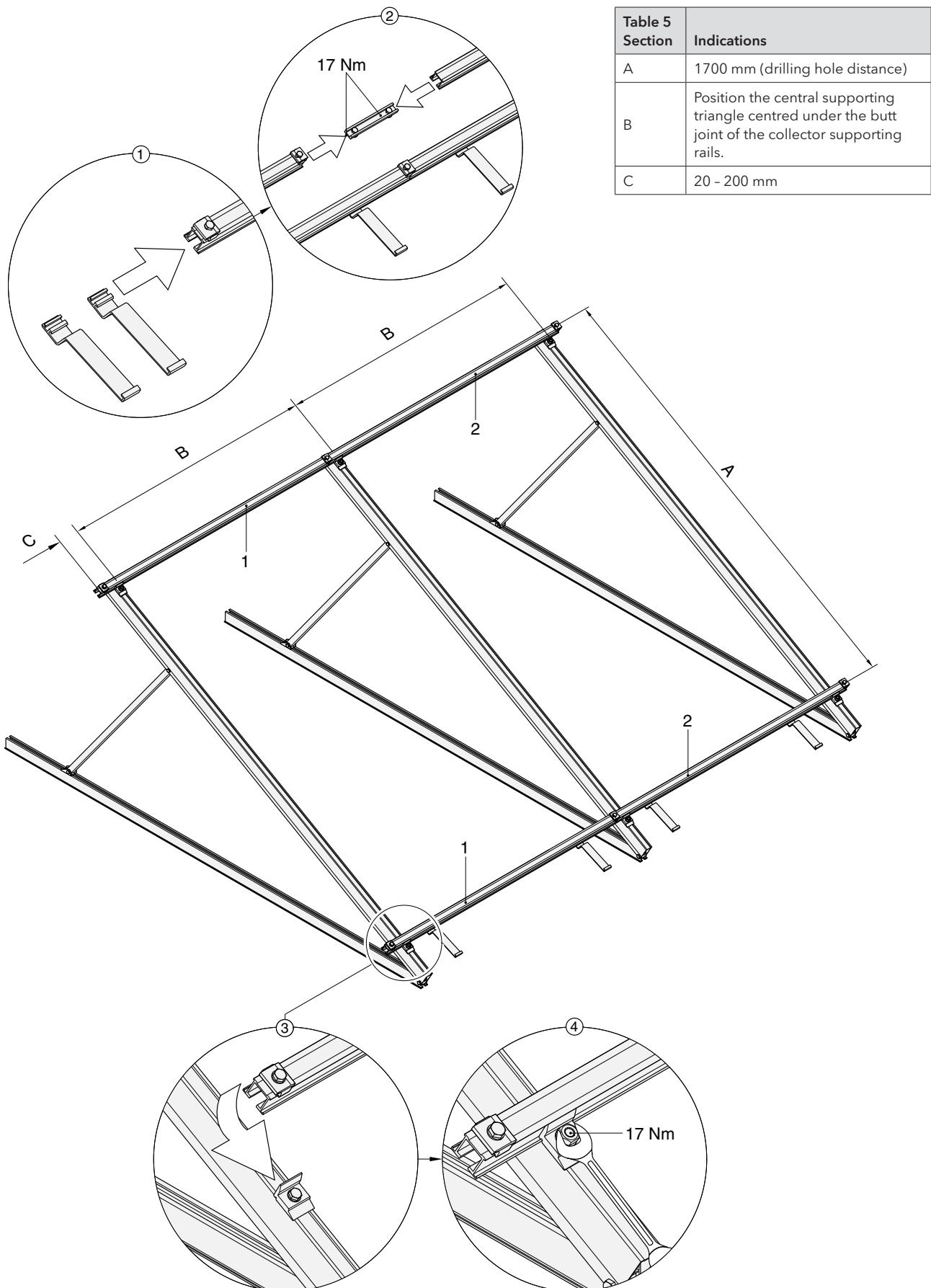

Figure 21 Overview supporting rail installation 1 rail with two collector clamps 2 rail with one collector clamp

5.2 Collector Installation

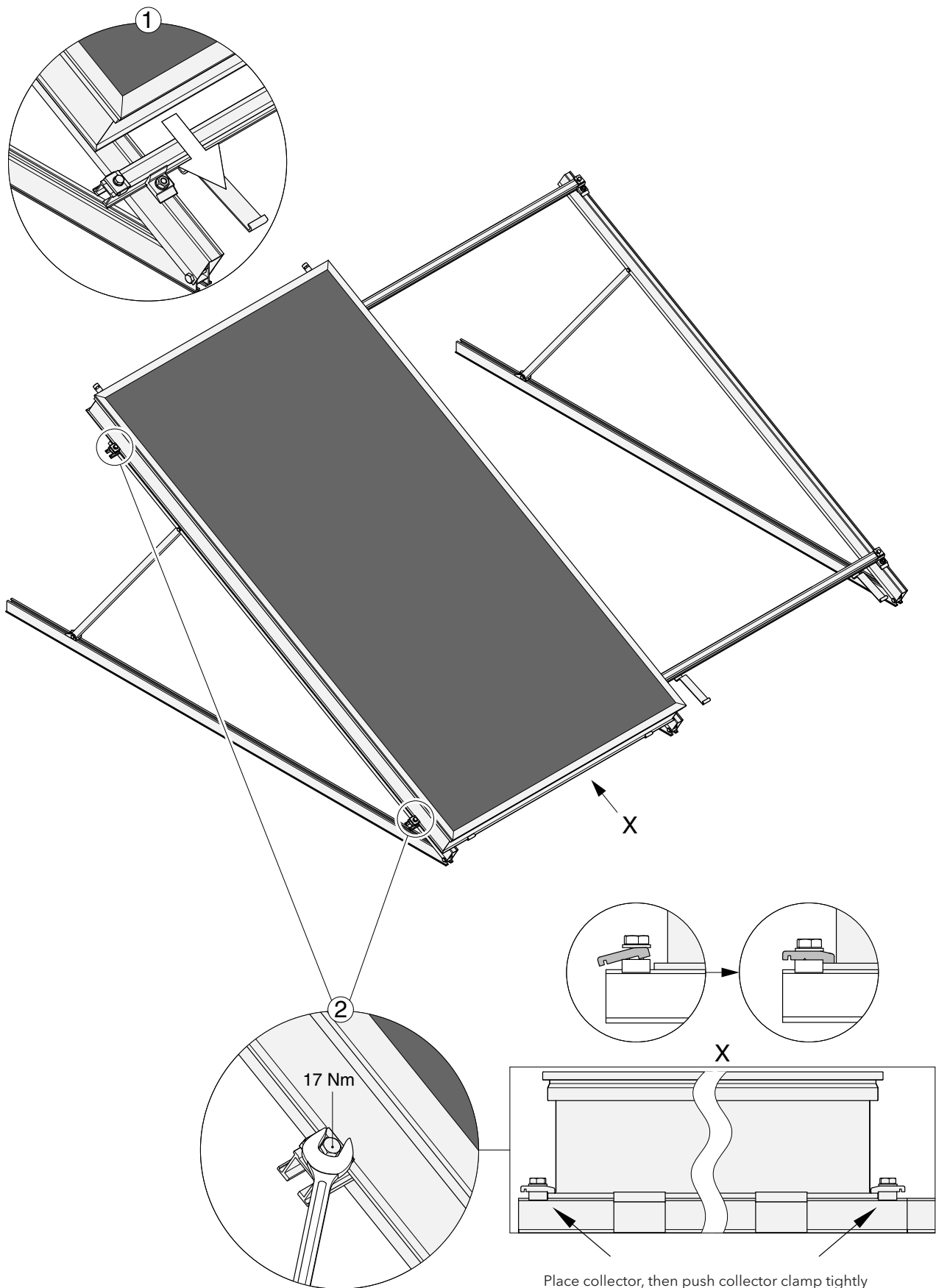

Figure 22 Installation of the first collector.

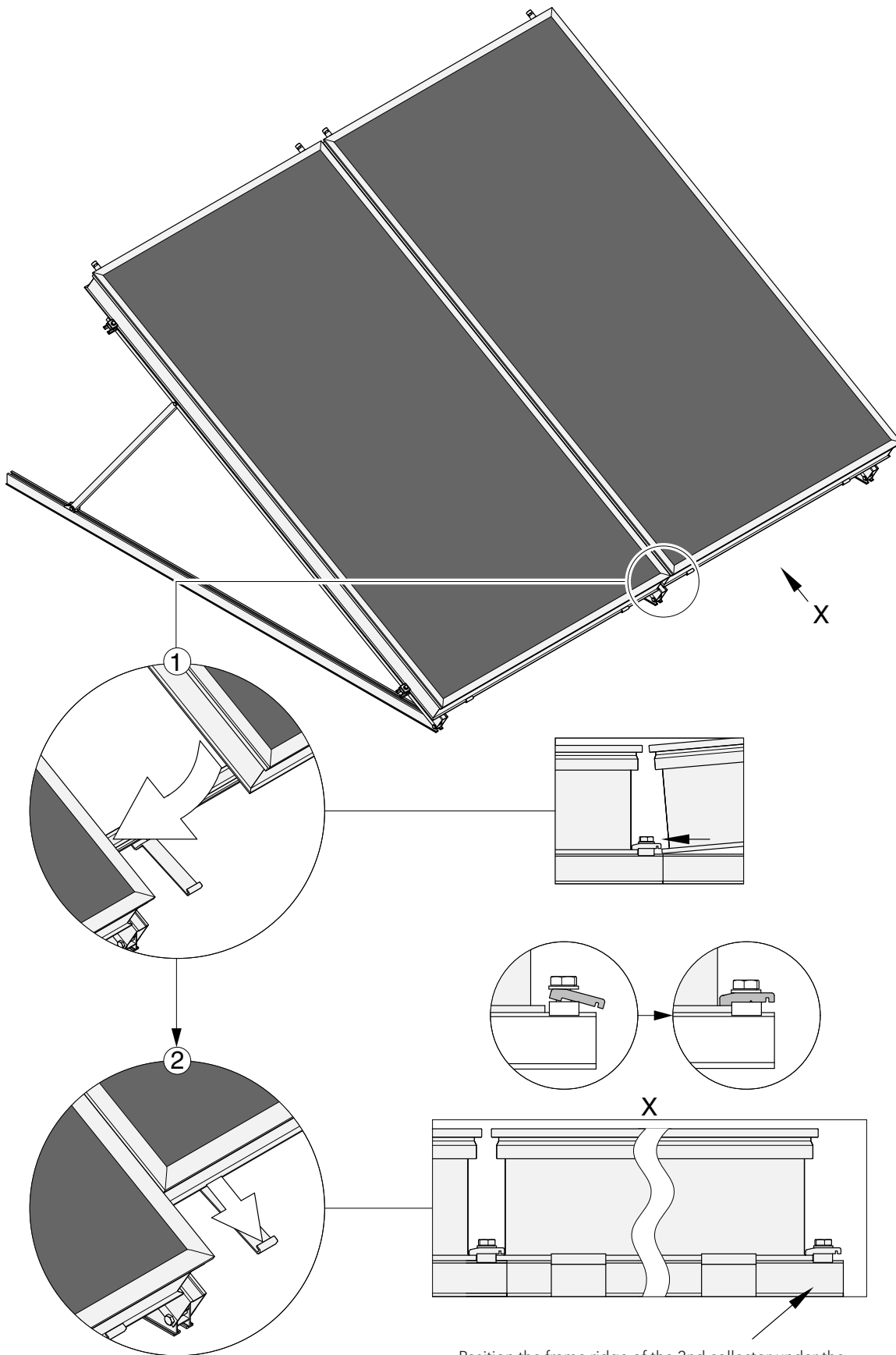

Figure 23 Installation of following collectors

Position the frame ridge of the 2nd collector under the fixed collector clamps at the side of the first collector. On the other side loosen collector clamps slightly, then push tightly against collector and tighten screw. Incorrectly positioned collector clamps may result in insufficient stability!



6. Sensor Installation

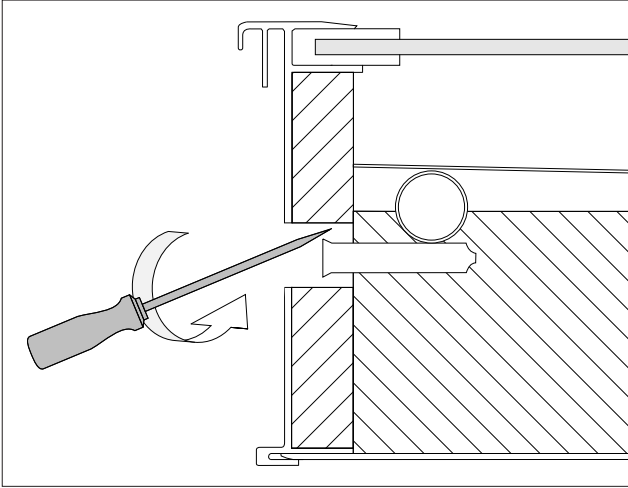

Figure 24 Remove rubber plug from frame. Possibly use screwdriver to lay open sensor sleeve.

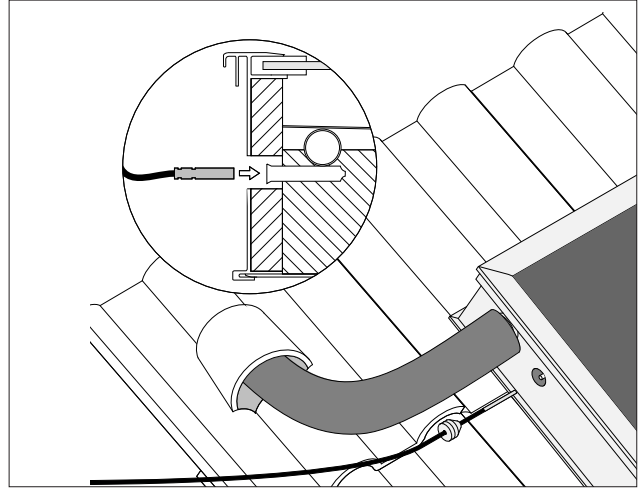
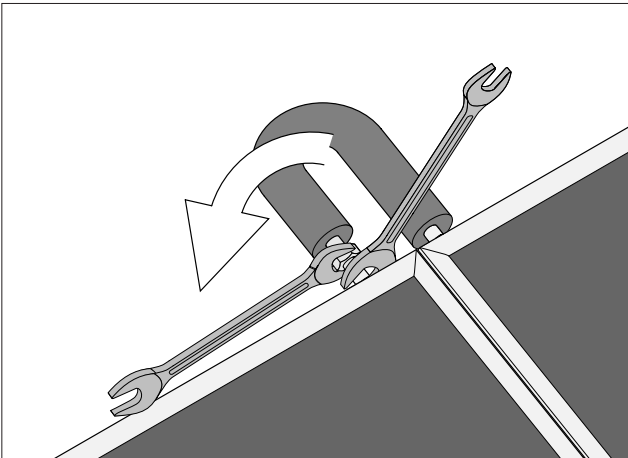



Figure 25 Pull sensor through rubber plug and insert sensor tip into sensor sleeve. Screw in rubber plug again.

7. Collector Connections



 Figure 26 Counter collector connection hose (vertical, free standing set-up) during tightening to protect collector connection and connection hose against damages.

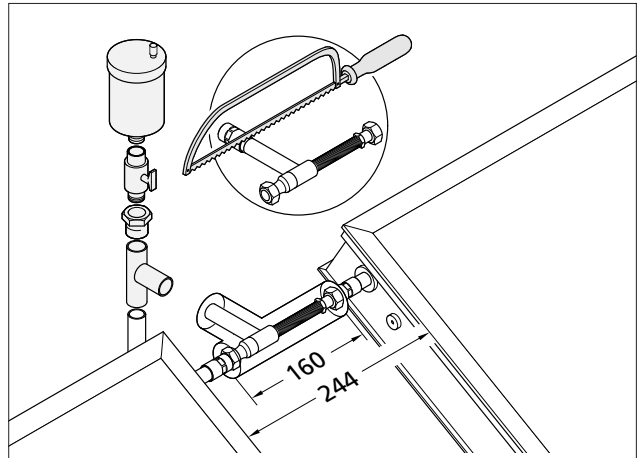

Figure 27 Installation dimensions for connection set prod. no. 190 202 30; Cut to size for compression or solder connections.

8. Accessories

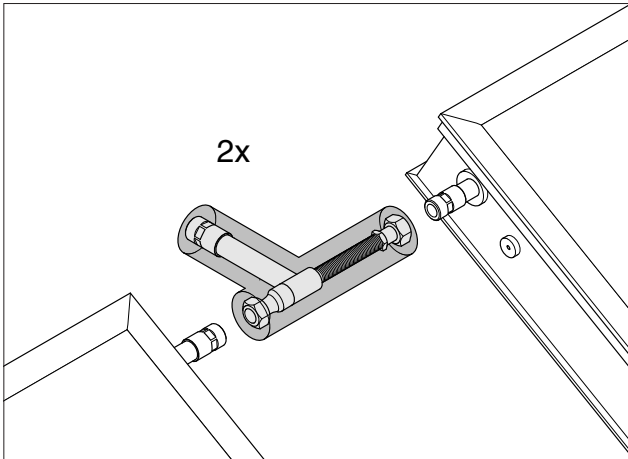

Figure 28 Connection set prod. no 190 202 30 for 2 horizontal collectors: 2 insulated T-connector pieces with 2 x 1/2" swivel nuts and 1 x 3/4" M thread.



Figure 29 Collector handles for easier collector transport (prod. no. 188 005 02)

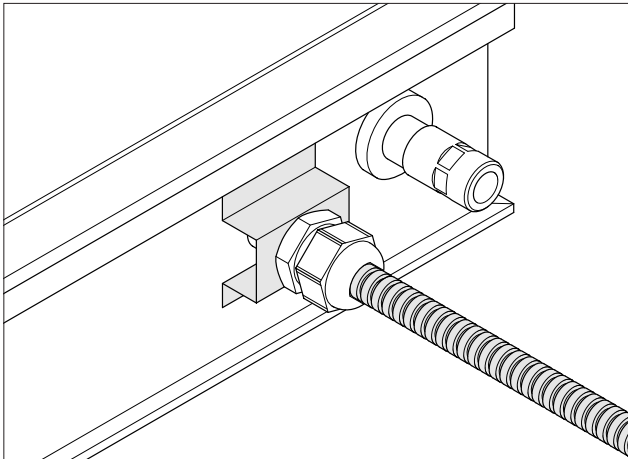

Figure 30 Optional sensor protection against marten bites (part no. 192 040 09 for black collectors, part no. 192 040 10 for aluminum colored collector frames).