

---

**Installation, use and maintenance guide**

**Thermopuffer 500**

**Thermocell 500**

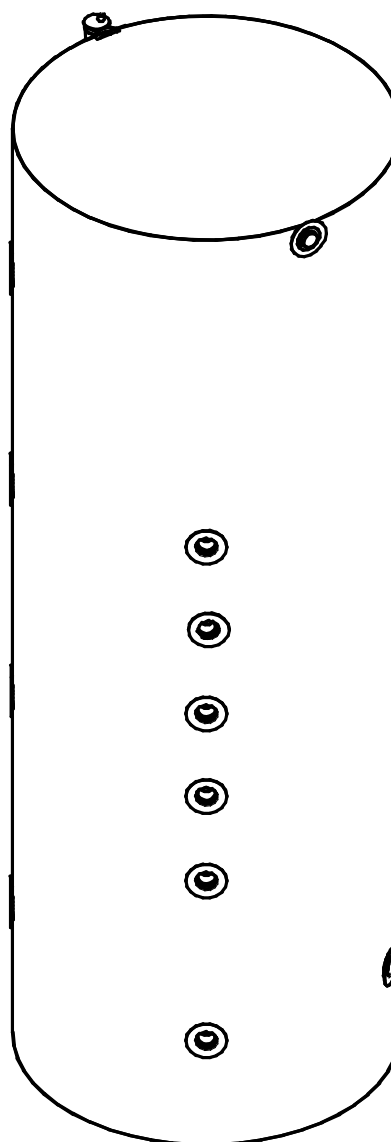
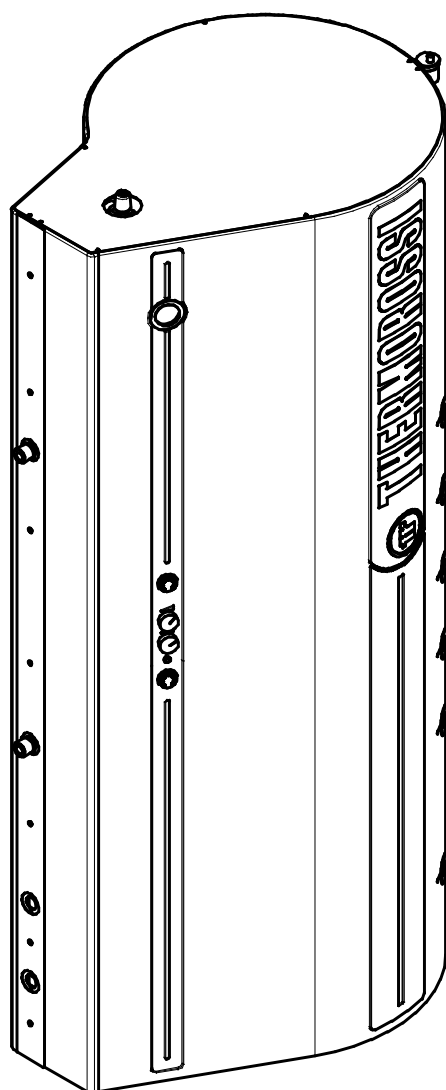

# CONTENTS

## DECLARATION OF CONFORMITY

<b>1.</b>	<b>INTRODUCTION .....</b>
1.1	General guidelines .....
1.2	Safety guidelines .....
1.3	Standards and recommendations .....
1.4	Transportation and storage .....
<b>2.</b>	<b>TECHNICAL CHARACTERISTICS .....</b>
<b>3.</b>	<b>INSTALLATION .....</b>
3.1	Positioning of the Thermocell / Thermopuffer .....
3.2	Electrical connection of the Thermocell.....
3.3	Assembly and electrical connection of the Thermopuffer with Thermocontrol (optional) .....
3.4	Hydraulic connection of the Thermocell .....
3.5	Hydraulic connection of the Thermopuffer .....
<b>4.</b>	<b>HYDRAULIC DRAWINGS .....</b>
4.1	Schematic drawing of typical hydraulic circuit for pellet boiler + Thermocell (or Thermopuffer) + additional Thermopuffer + high temperature heating and low temperature heating .....
4.2	Schematic drawing of typical hydraulic circuit for pellet boiler + Thermocell + high temperature heating and low temperature heating .....
4.3	Schematic drawing of typical hydraulic connection of solar panels to the Thermocell .....
4.4	Schematic drawing of typical hydraulic circuit for pellet boiler + Thermocell + high temperature heating and low temperature heating + solar panels + Central heating cooker / Heater .....
<b>5</b>	<b>ADJUSTMENT OF THE DOMESTIC WATER TEMPERATURE IN THE "SANFAST" .....</b>
<b>6</b>	<b>SPARE PARTS .....</b>

## "EC" DECLARATION OF CONFORMITY



**THERMOROSSI**

Via Grumolo, 4 36011 ARSIERO (VI)  
tel. 0445 741310 fax.0445 741657

The Manufacturer, Thermorossi S.p.A., Via Grumolo 4 - ARSIERO (VI), hereby declares under his own responsibility that Thermopuffer and Thermocell are designed and manufactured in compliance with CE marking requirements.

ARSIERO, March 2010

**THERMOROSSI S.p.A.**



# 1 INTRODUCTION

## 1.1 GENERAL GUIDELINES

This installation, use and maintenance guide is an integral and essential part of the product and must be kept by the user. Before commencing with the installation, use and maintenance of the product, carefully read all the instructions contained in this booklet. At the time of installation of the product all local regulations, including those that refer to national and European regulations, must be observed. The Manufacturer recommends carrying out all the maintenance operations described in this manual.

This appliance must only be used as intended by the manufacturer. Any other use is considered incorrect and therefore hazardous; consequently, the user shall be totally liable for the product if used improperly. Installation, maintenance and repairs must be carried out by personnel with professional qualifications and in compliance with current regulatory standards and in accordance with the instructions of the manufacturer of the appliance. Use only original spare parts.

Incorrect installation or poor maintenance could injure or damage people, animals or things; in this case the manufacturer shall be relieved of all responsibility. Before commencing any cleaning or maintenance operation ensure that the product has been disconnected from the mains power supply by means of the main system switch or some other disconnecting device installed upstream from the product. Any repairs or actions carried out on any systems, components or internal parts of the product, or on any of the accessories supplied with it, that are not specifically authorised by Thermorossi s.p.a, will automatically void the warranty and the manufacturer's responsibility, pursuant to D.P.R. 224 of 24/05/1988, art. 6/b . Use only original Thermorossi spare parts. If the product is sold or transferred to another user ensure that the guide is handed over with it.

*Thermorossi S.p.A. maintains the author's rights on these service instructions. The information in this booklet may not be reproduced or given to third parties or used for competitive purposes without the appropriate authorization.*

## 1.2 SAFETY GUIDELINES



### PERSONAL INJURY

This safety symbol identifies important messages throughout the manual. Read the information marked by this symbol carefully as non-observance of this message can cause serious injury to persons using the product.



### DAMAGE TO PROPERTY

This safety symbol identifies messages or instructions that are fundamental for the product to function well. To avoid serious damage to the product adhere strictly to these instructions.



### INFORMATION

This symbol indicates important instructions for good functioning of the product. If this information is not correctly observed, the performance of the heater will not be satisfactory.

## 1.3 STANDARDS AND RECOMMENDATIONS

### NORMATIVE REFERENCES :

- Standard CEI 61/50

- Standard CEI 64-8 (IEC 364)

- Standard CEI EN 60204



### RECOMMENDATIONS

Before using the product, carefully read every section of this instruction manual as knowledge of the information and the regulations contained in it are essential for a correct use of the product.



The entire operation concerning the connection of the electric panel must be carried out by expert personnel; no responsibility will be accepted for damages, even to third parties, if the instructions for installation, use and maintenance of the appliance are not followed scrupulously. Modifications made to the product by the user or on his behalf, must be considered to be under his complete responsibility.

The user is responsible for all the operations required for the installation and maintenance of the appliance before and during its use.

### GENERAL WARNINGS

**Caution:** the appliance must be connected to a system provided with a PE conductor (in compliance with the specifications of 73/23/EEC, 93/98/EEC, concerning low voltage equipment). Before installing the appliance check the efficiency of the earth circuit of the power supply system.

**Caution:** the power supply line must have a section which is suitable for the power of the equipment. The cable section must in any case be no less than 1.5 mm<sup>2</sup>. The equipment must be powered with a voltage of 220/240 V and 50 Hz. Voltage variations which exceed or are lower than 10% of the nominal value can cause poor functioning or damage the electrical device. The product must be positioned in such a way that it is easily accessible. Ensure that a suitable differential switch is installed upstream from the equipment.

## 1.4 TRANSPORTATION AND STORAGE

**TRANSPORTATION AND HANDLING:** Take special care to protect all the fragile parts from mechanical impact which could damage them and their correct functioning.

**STORAGE:** The product must be stored in a humid-free environment and sheltered from the weather; it is inadvisable to store the product directly on the floor. It is inadvisable to store the equipment for long periods of time.



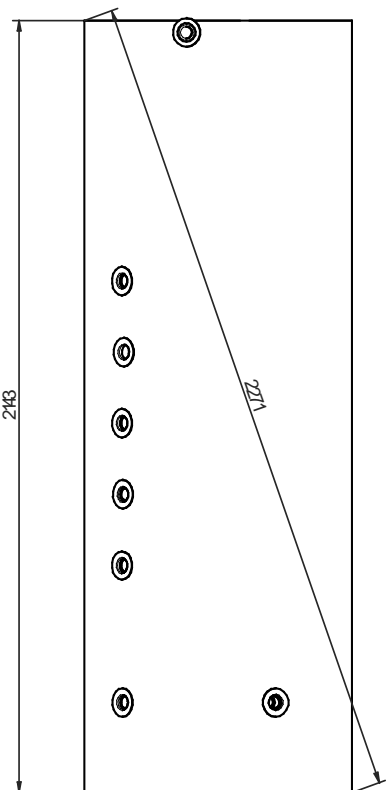
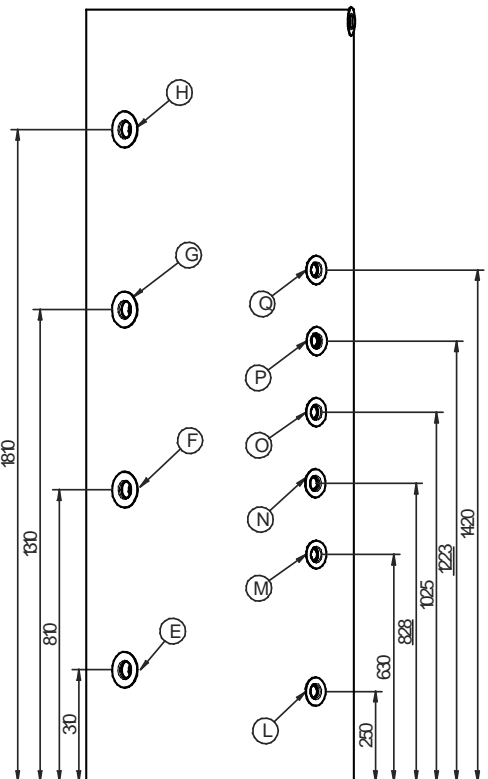
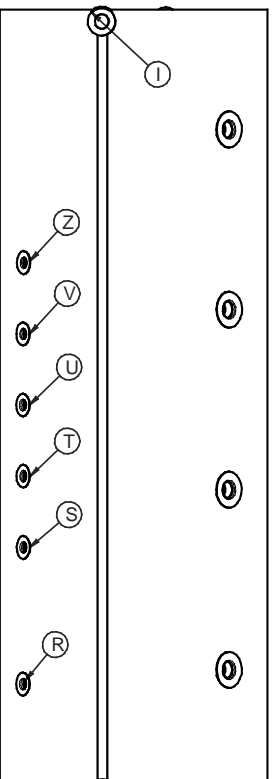

Thermopuffer	
<b>E</b>	Connection pipe to another puffer (1"1/2)
<b>F</b>	Connection pipe to another puffer (1"1/2)
<b>G</b>	Connection pipe to another puffer (1"1/2)
<b>H</b>	Connection pipe to another puffer (1"1/2)
<b>I</b>	Connection pipe to automatic vent (1")
<b>L</b>	Boiler-system connection (1")
<b>M</b>	Boiler-system connection (1")
<b>N</b>	Boiler-system connection (1")
<b>O</b>	Boiler-system connection (1")
<b>P</b>	Boiler-system connection (1")
<b>Q</b>	Boiler-system connection (1")
<b>R</b>	Pocket for probes (1/2")
<b>S</b>	Pocket for probes (1/2")
<b>T</b>	Pocket for probes (1/2")
<b>U</b>	Pocket for probes (1/2")
<b>V</b>	Pocket for probes (1/2")
<b>Z</b>	Pocket for probes (1/2")

Insulation thickness 75 mm  
 Puffer capacity 500 lt  
 Puffer max working pressure 3 bar  
 °C max 100

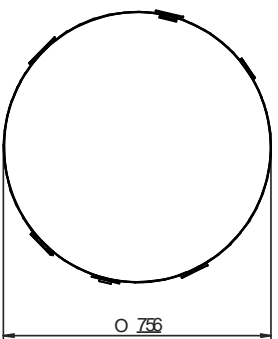

The system operating pressure must always be above the expansion tank preload:  
 2 bar for the expansion tank 1.5 bar.

### 3 INSTALLATION

#### 3.1 Positioning of the Thermocell - Thermopuffer

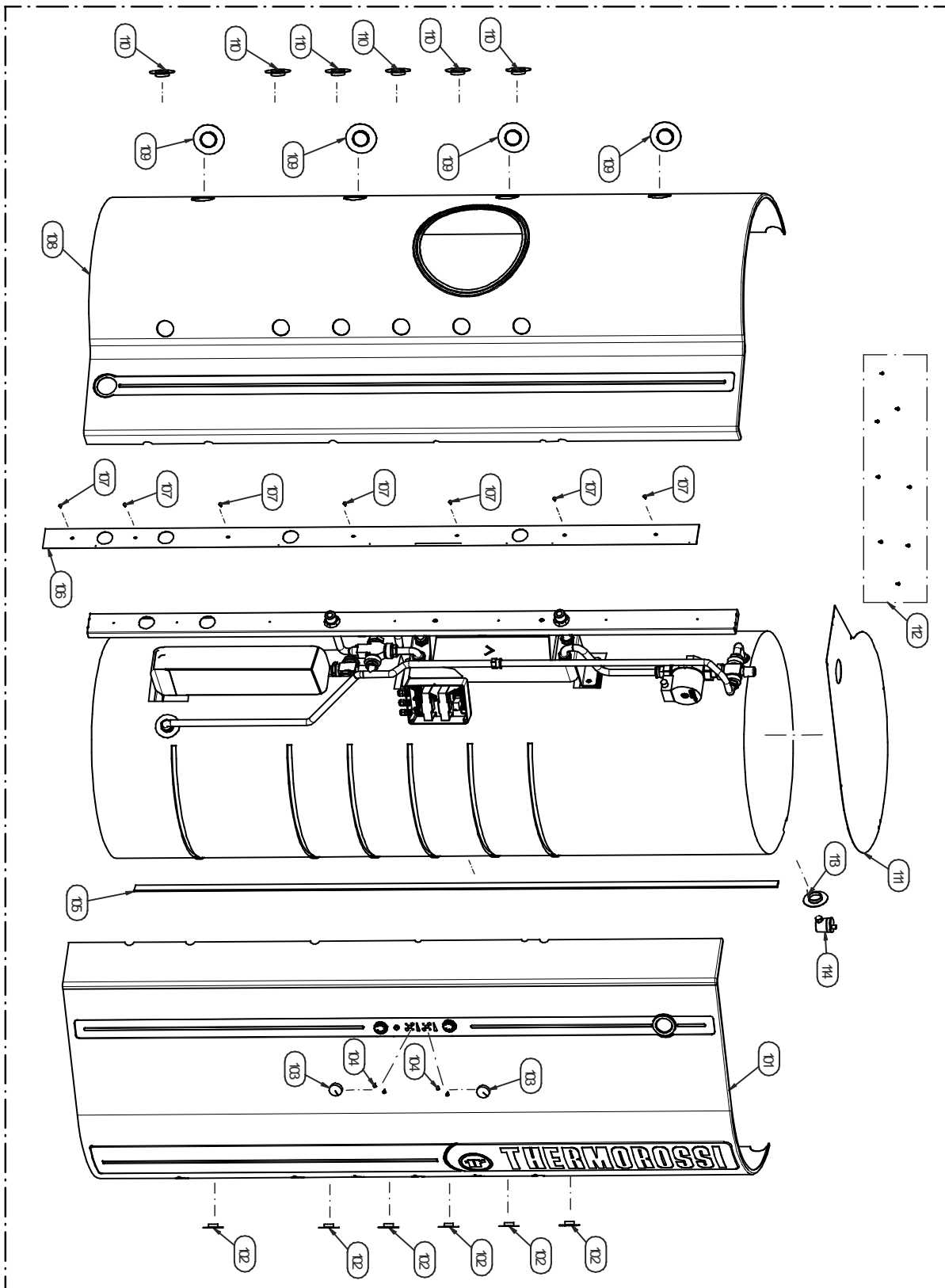

**CAUTION:** Always use trolleys to move the appliance and the appliance must always be in a vertical position. Follow the general guidelines set out in paragraph 1.1 to the letter. Keep in mind that the flooring of the room in which the product is to be installed must withstand the combined weight of the appliance and the water contained in it.

To prevent damaging the casing of the Thermocell during the positioning procedure we suggest disassembling it then re-assembling it when in position.

Remove the top (111) by undoing the screws (112), remove the purge valve (114) and the plug (113).

Remove the profile (105), the plugs (102), the 2 knobs (103) and the 4 screws (104).

Next remove the profile (106) by undoing the screws fastened to it (107), then move the casing (101) (pay attention to the electrical wiring of the green LED fixed to it). Now remove the plugs (109) and plugs (110) then move the casing (108) (pay attention to the electrical wiring). At this point position the Thermocell then, once it is correctly positioned, reassemble all of the above parts.

It is not necessary to remove the casing of the Thermopuffer in order to position it.

### 3.2 Electrical connection of the Thermocell

For the electrical connections of the Thermocell follow the indications illustrated in the figure below on the left (with regard to this see also the instructions given in the Thermocontrol manual (manual supplied with the Thermocell)). Note also the electrical wiring diagram provided below on the right.

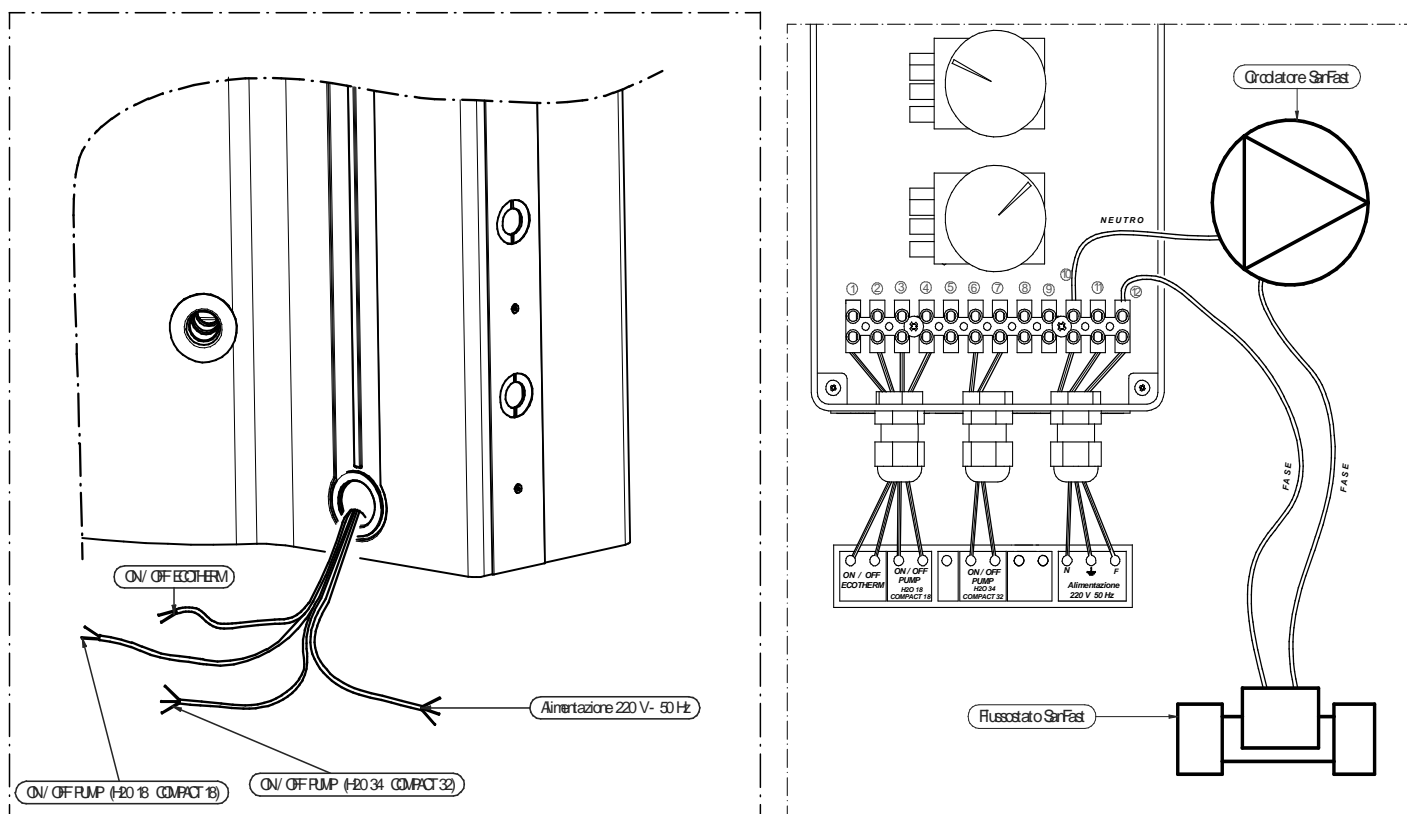

#### LEGENDA

Alimentazione

Circolatore

Flussostato

Fase

Neutro

#### KEY

Power supply

Circulating pump

Flow switch

Phase

Neutral

### 3.3 Assembly and electrical connection of the Thermopuffer with Thermocontrol (optional)

To mount the Thermocontrol to the Thermopuffer follow the indications illustrated in the images below:

Make the electrical connections as indicated in the drawing below and in the Thermocontrol manual (manual supplied when the Thermocontrol is purchased).

Fix the 2 thermostats in their seats.

Pull off the 2 knobs from the Thermocontrol

Remove the plastic cover of the Thermocontrol the fix the Thermocontrol to the Support with the 4 screws provided.

Next fix the 2 previously removed knobs.

Then fix the bracket to the Thermopuffer using the 6 screws provided.

Now attach the complete support to the bracket and position the thermostat and thermometer bulbs as indicated in the hydraulic drawings provided in this manual.

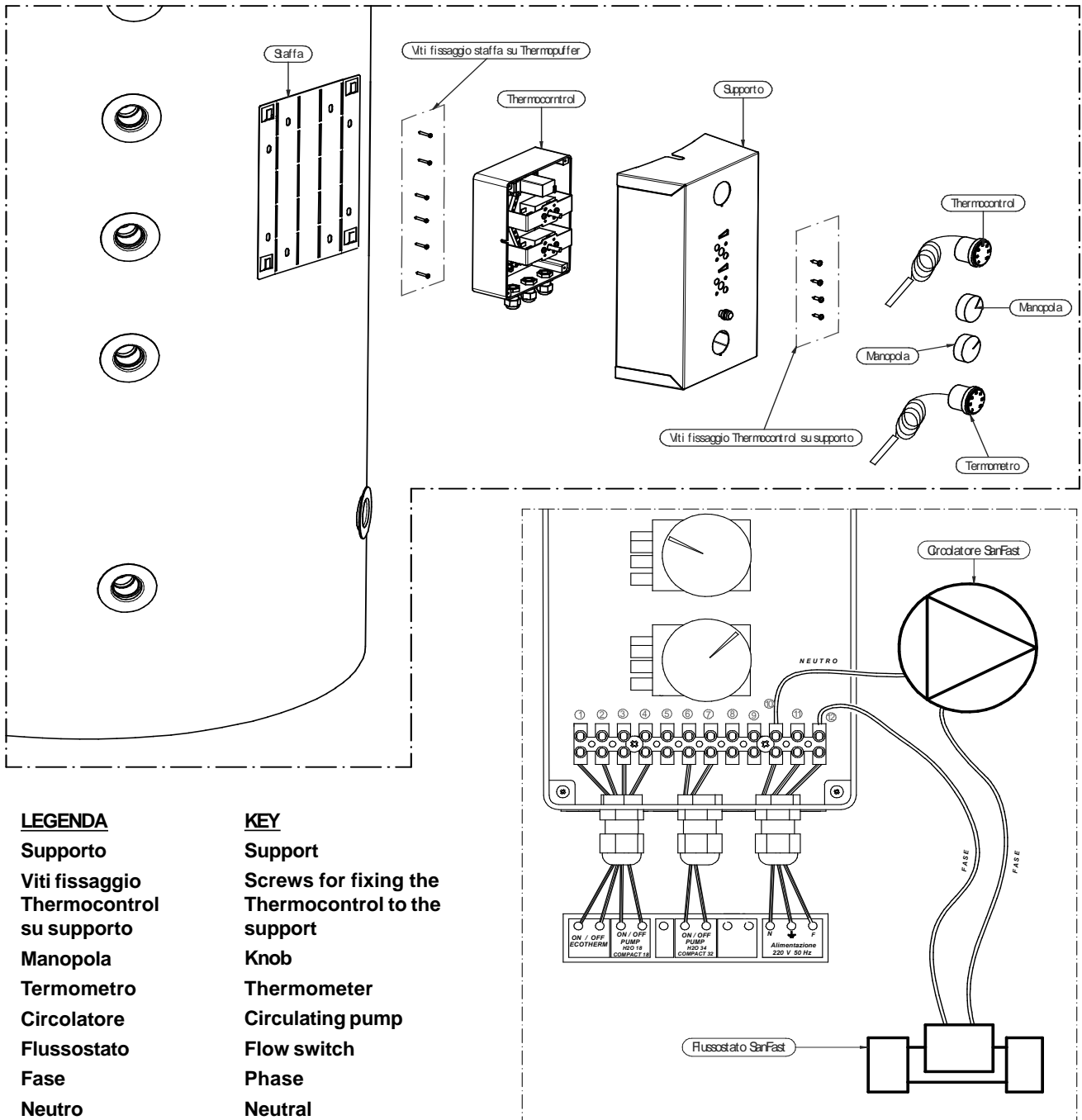

#### LEGENDA

Supporto  
 Viti fissaggio  
 Thermocontrol  
 su supporto  
 Manopola  
 Termometro  
 Circolatore  
 Flussostato  
 Fase  
 Neutro

#### KEY

Support  
 Screws for fixing the  
 Thermocontrol to the  
 support  
 Knob  
 Thermometer  
 Circulating pump  
 Flow switch  
 Phase  
 Neutral



### 3.4 Hydraulic connection of the Thermocell

Follow the indications illustrated in the drawing below as well as the detailed instructions below for the hydraulic connections of the Thermocell:

Remove the top (111) by undoing the screws (112), remove the purge valve (114) and the plug 113. Remove the profile (105), the plugs (102), the 2 knobs (103) and the 4 screws (104). Next remove the profile (106) by undoing the screws (107).

Next move the casing (101) (pay attention to the electrical wiring of the green LED fixed to it).

Now connect the solar heat exchanger with tubes (Y and X) (tubes not supplied). Next apply the fittings (C) and (D) to the domestic water system. Next re-assemble all the above parts. Next make the hydraulic connections between the boiler and system and the Thermocell by following the indications illustrated in the hydraulic drawings.

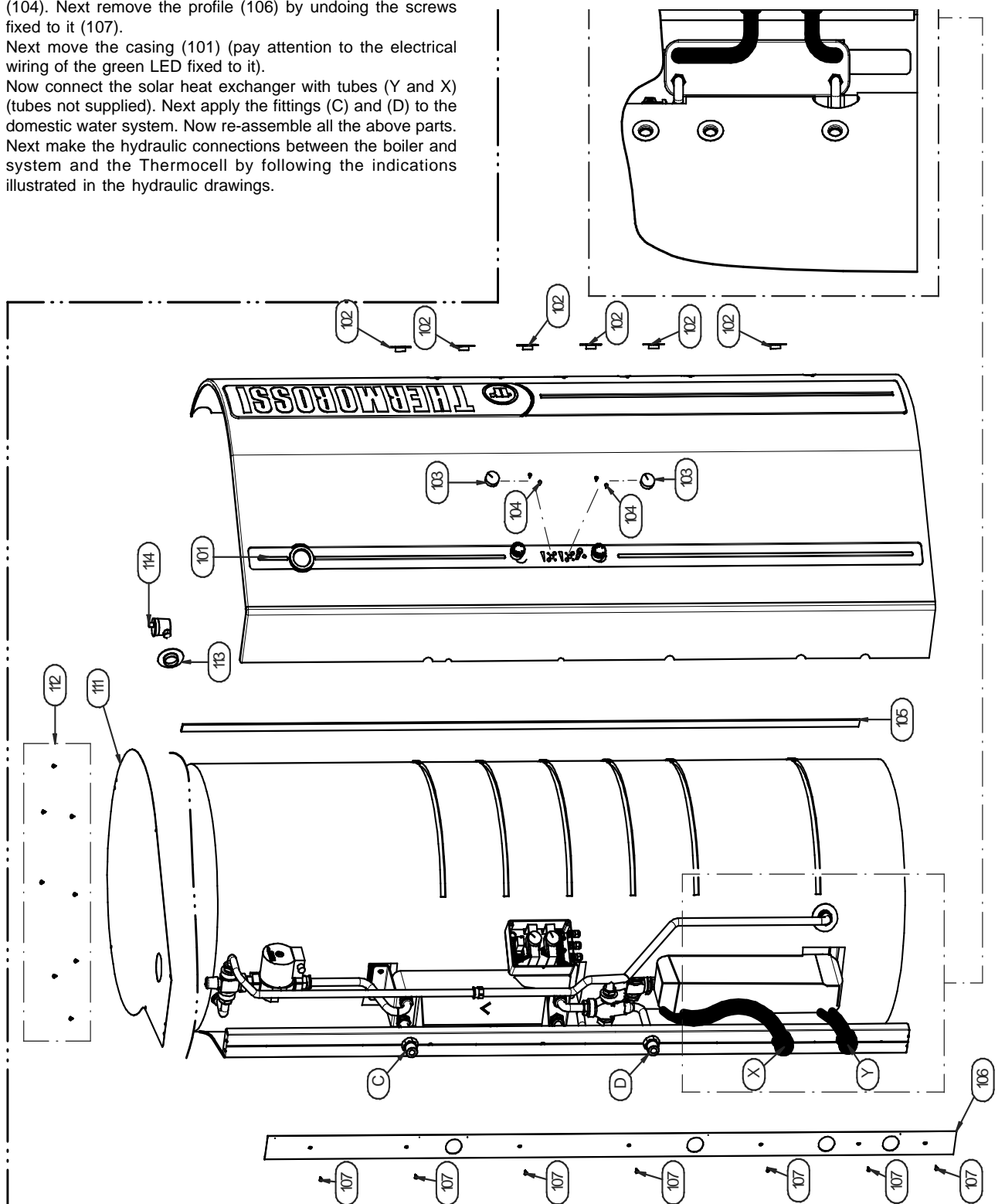

### 3.5 Hydraulic connection of the Thermopuffer

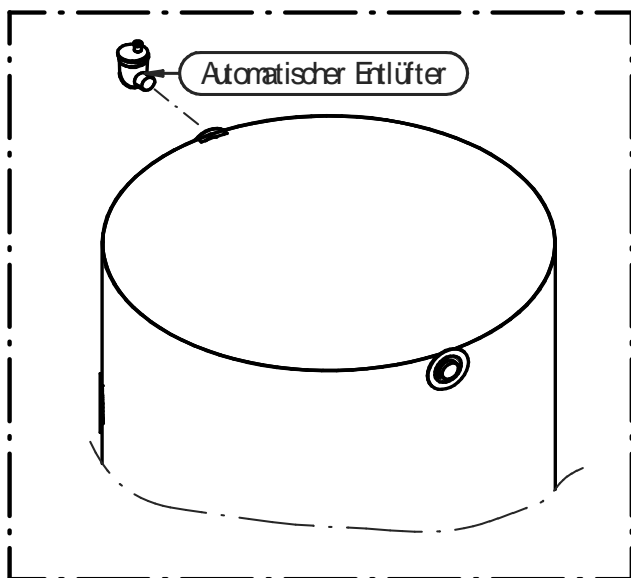

For the hydraulic connections of the Thermopuffer the automatic purge valve (not supplied) must be installed as indicated below. Next make the hydraulic connections between the boiler and system and the Thermopuffer by following the indications illustrated in the hydraulic drawings.

4 HYDRAULIC DRAWINGS  
 4.1 SCHEMATIC DRAWING OF TYPICAL HYDRAULIC CIRCUIT FOR PELLETT BOILER + THERMOCELL (OR THERMOPUFFER) + ADDITIONAL THERMOPUFFER + HIGH TEMPERATURE HEATING AND LOW TEMPERATURE HEATING

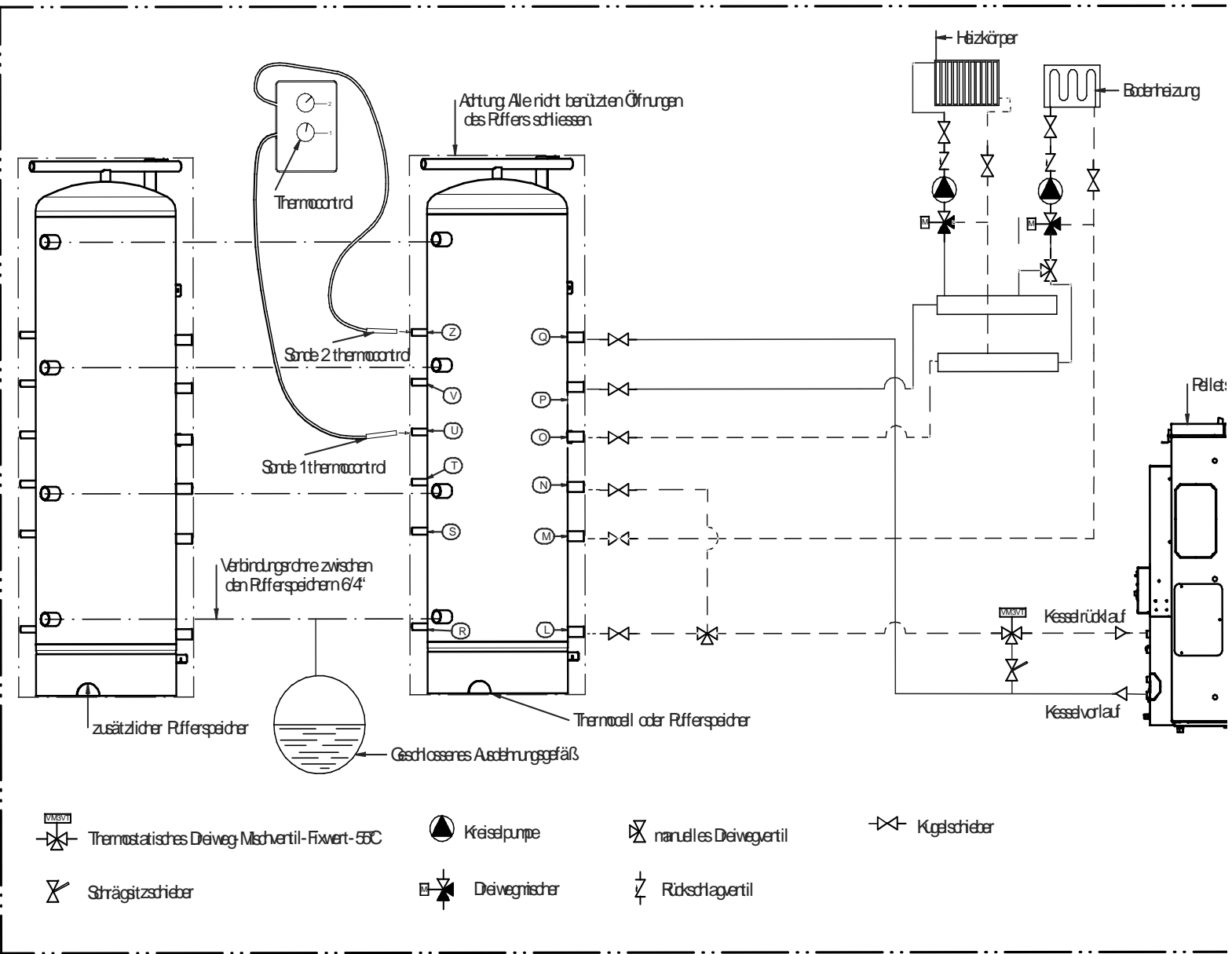



#### 4.2.1 ELECTRICAL WIRING DIAGRAM FOR DOMESTIC WATER CIRCULATING PUMP

**CAUTION:** The electrical connection of the "domestic water circulating pump" (not supplied) and the "thermostat set at 35°C" (not supplied) must be carried out in accordance with the instructions set out below.

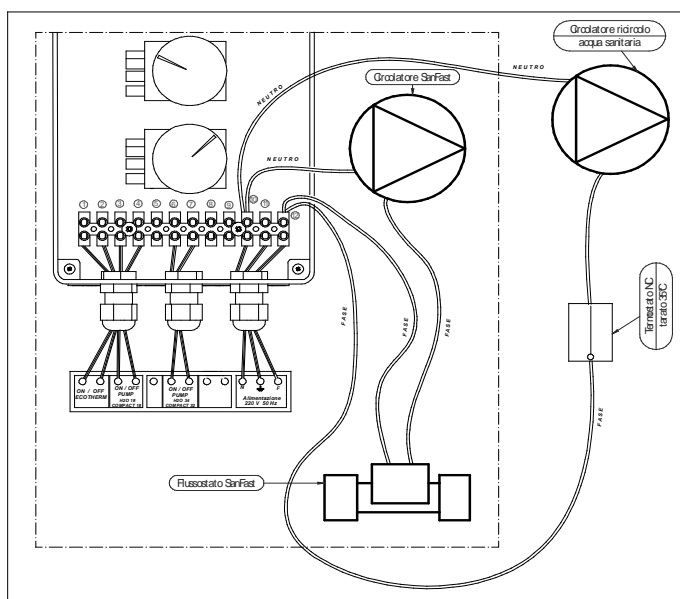

<u>LEGENDA</u>	<u>KEY</u>
Circolatore SanFast	Circulating pump SanFast
Circolatore ricircolo acqua sanitaria	Domestic water circulating pump
Termostato NC tarato a 35°C	Thermostat NC set at 35°C
Flussostato SanFast	Flow switch SanFast
Neutro	Neutral
Fase	Phase
Alimentazione	Power supply

#### 4.3 SCHEMATIC DRAWING OF TYPICAL HYDRAULIC CONNECTION OF SOLAR PANELS TO THERMOCELL

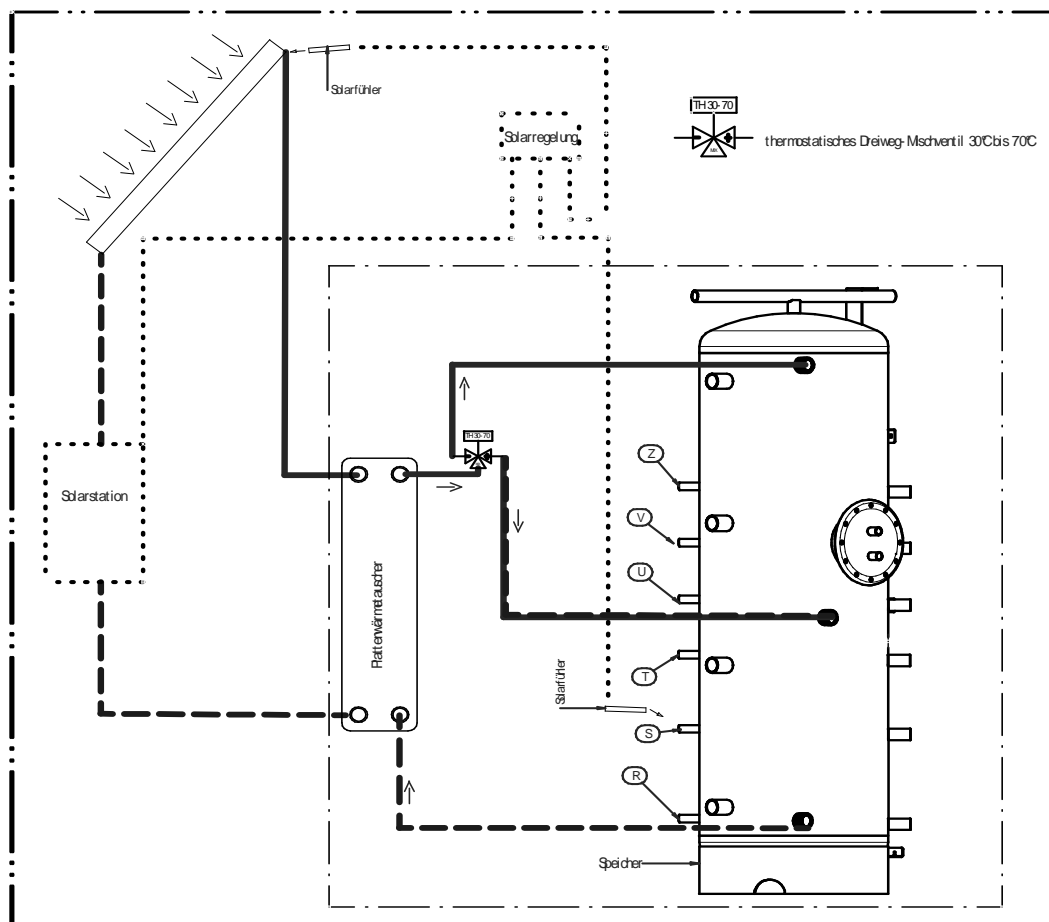

**4.4 SCHEMATIC DRAWING OF TYPICAL HYDRAULIC CIRCUIT FOR PELLET BOILER + THERMOCELL + HIGH TEMPERATURE HEATING AND LOW TEMPERATURE HEATING + SOLAR PANELS + CENTRAL HEATING COOKER / WOOD-FIRED HEATER.**

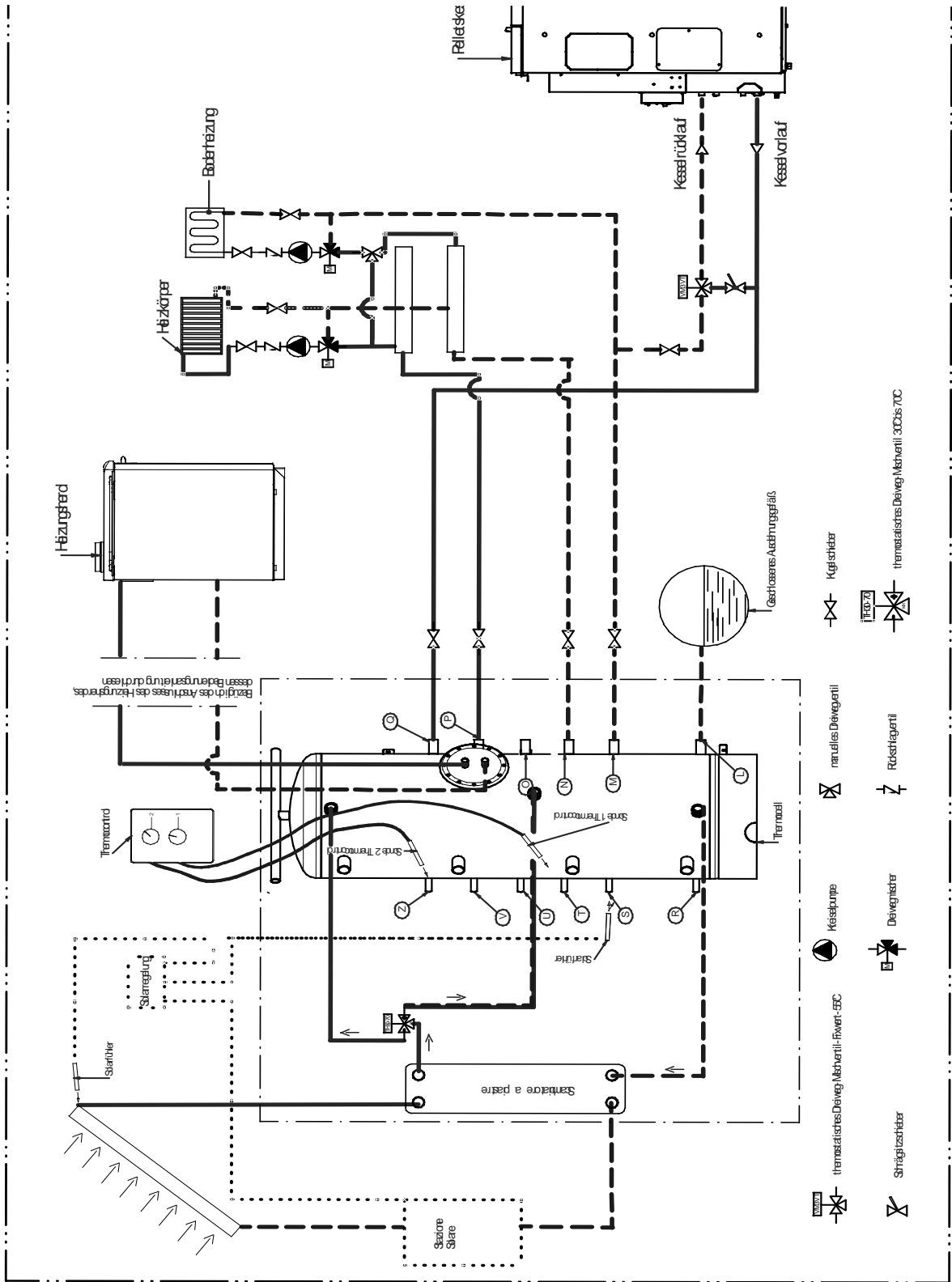

## 5 ADJUSTMENT OF THE DOMESTIC WATER TEMPERATURE

The domestic hot water can be adjusted to a temperature ranging between 30 °C and 70°C by turning the knob indicated in the figure below: the maximum obtainable temperature always depends on the temperature of the puffer. Turn the knob clockwise to adjust the temperature to a minimum value of 30°C, turn the knob counter clockwise to a maximum value of 70°C.

**CAUTION:** if the water hardness exceeds 14° French (average hardness ), install a water softener .  
The water hardness value is available from your Urban Water Authority.

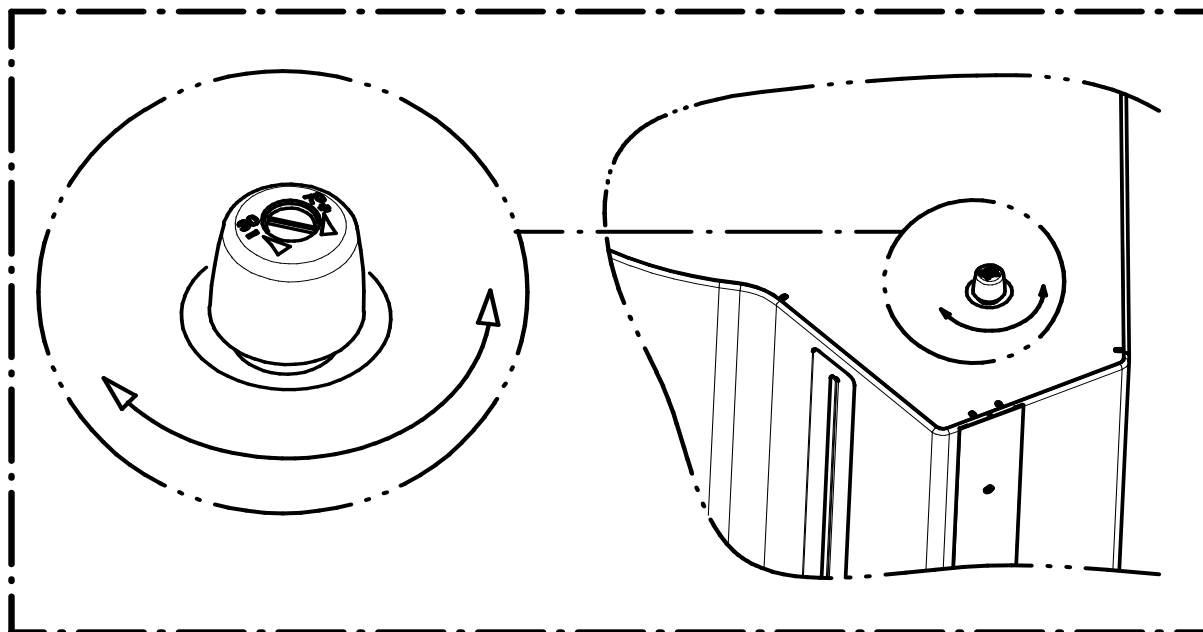

## 6 SPARE PARTS

### 6.1 THERMOCELL SPARE PARTS (page 1 of 2)

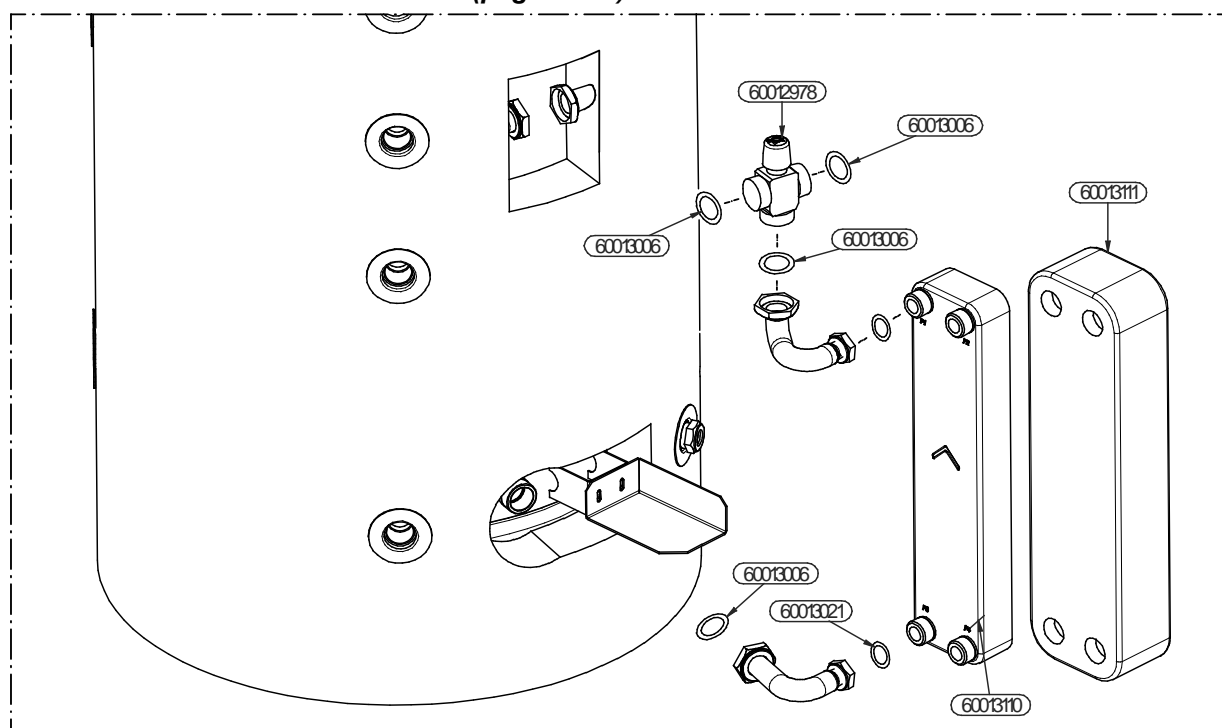

6.2 THERMOCELL SPARE PARTS (page 2 of 2)

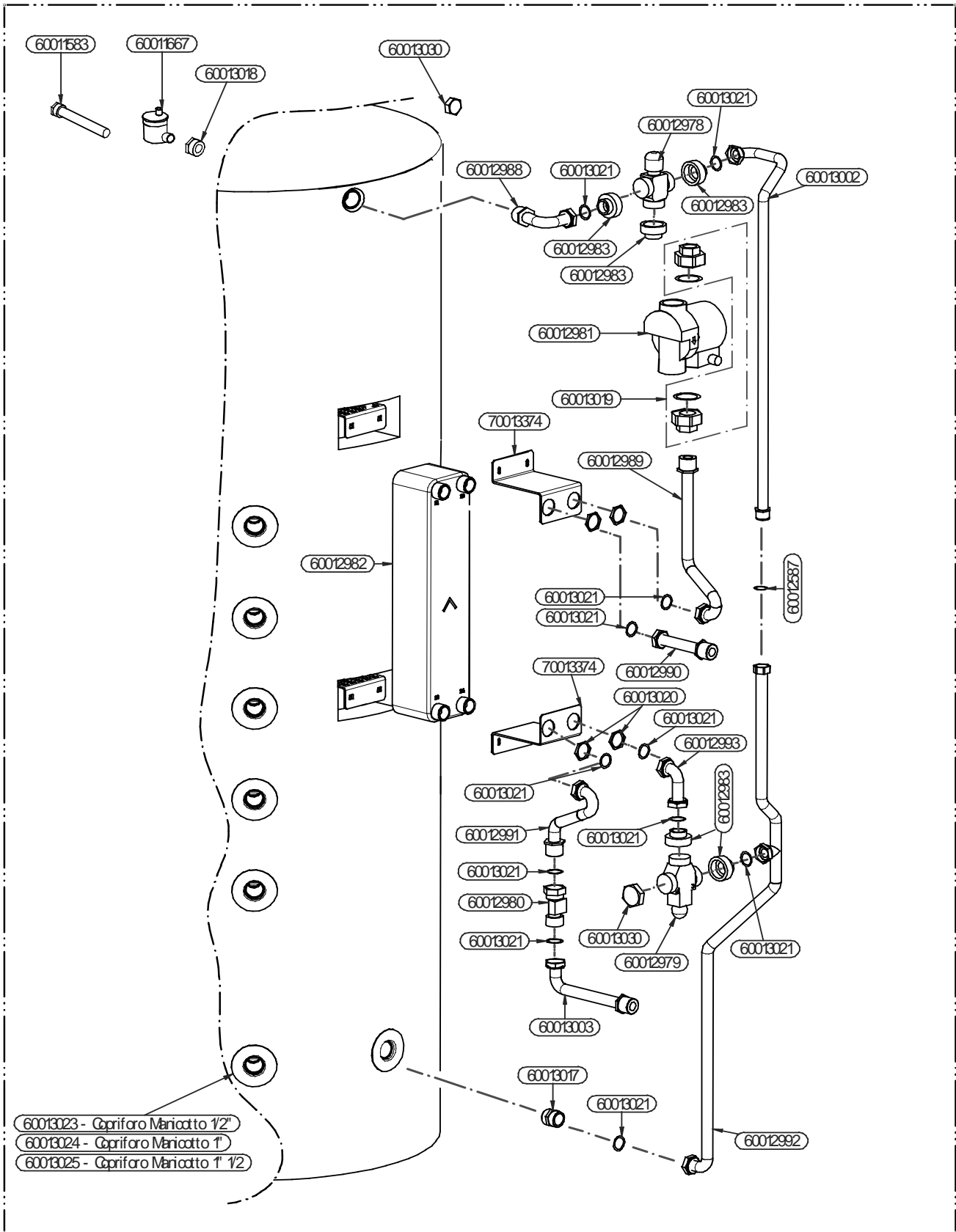



**6.3 THERMOPUFFER SPARE PARTS**

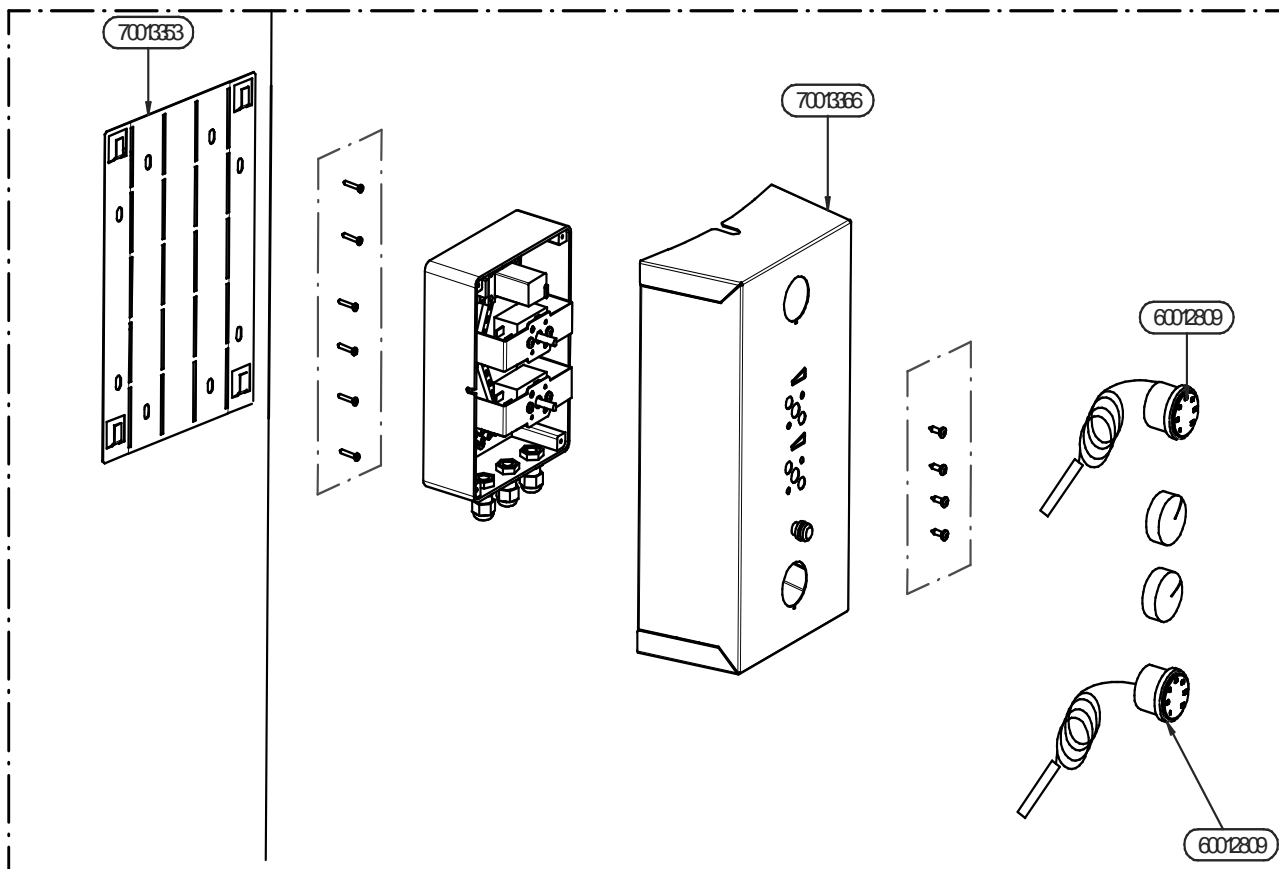

**6.3.3 THERMOCELL / THERMOPUFFER SPARE PARTS (OPTIONAL)**

**LEGENDA Pag. 16**  
Copriforo Manicotto

**KEY Page 16**  
Plastic Hole Plug

**LEGENDA Pag. 17**  
Zoccolo Relè  
Relè

**KEY Page 17**  
Relay Base  
Relay

