



THERMOROSSI

TECNOLOGIE ED INNOVAZIONI PER IL RISCALDAMENTO

H₂O 18 - COMPACT 18



INSTALLATION, USE AND MAINTENANCE GUIDE
ECOTHERM H₂O 18 - COMPACT 18

CONTENTS

1. INTRODUCTION

1.1 General guidelines

1.2 Safety guidelines

1.3 Standards and recommendations

1.4 Transportation and storage

2. TECHNICAL CHARACTERISTICS

2.1 Technical data.....

3. GENERAL DESCRIPTION

3.1 Operating technology

3.2 Pellets

3.3 The feedbox.....

3.4 Main components of heater mod. H2O 18 and boiler mod. Compact 18.

4. INSTALLATION

4.1 Heater / boiler location.....

4.2 Mounting boiler / heater casing.

4.2.1 Mounting Metalcolor / Easycasing for heater H2O

4.2.2 Mounting rectangular ceramic tile casing for heater H2O.

4.2.3 How to mount Compact boiler casing.

4.2.4 How to install the additional hopper (optional) with Compact boiler

4.2.5 Fastening additional hopper (optional) to Compact boiler

4.3 Hydraulic drawing for heater H2O / Compact

4.4 Example of hydraulic drawing for H2O / Compact only heating

4.5 Example of hydraulic drawing for H2O / Compact with interspaced boiler tubes

4.6 Example of hydraulic drawing H2O / Compact with boiler coils and use of Thermocontrol (optional)

4.7 Example of hydraulic drawing H2O / Compact + Thermocell (or Thermopuffer) + additional Thermopuffer + High temperature heating and low temperature heating.

4.8 Instructions for executing the hydraulic system closed expansion tank

4.9 Example of hydraulic drawing for H2O / Compact with puffer system, solar panels and heating with radiating panels

4.11 Mounting the "Kit for the production of instant domestic hot water " (optional)

5. USE OF THE HEATER / BOILER

5.1 Description of control panel

5.2 Description of rear panel

5.3 Day and time setting

.....

5.4 Chronothermostat: ON/OFF programming

.....

5.5 Language selection

.....

5.6 Operating level setting

.....

5.7 Water pressure in the generator

5.8 Action temperature setting "Sensor 1 Thermocell" and " Sensor 2 Thermocell " as indicated in the hydraulic drawing para. 4.8

5.9 Information about how the generator works

.....

5.10 Boiler water pressure control.

.....

5.11 Switching on the heater H2O / boiler Compact

.....

5.12 Adjusting the combustion of the heater H2O / boiler Compact.

.....

5.13 Switching off the heater H2O / boiler Compact..

.....

6. ADDITIONAL ROOM TEMPERATURE THERMOSTAT AND ADDITIONAL CHRONOTHERMOSTAT (NOT SUPPLIED)

6.1 Operating with the additional room temperature thermostat (not supplied)

6.2 Operating with the additional chronothermostat (not supplied)

.....

7. CLEANING AND MAINTENANCE

.....

7.1 Foreword

.....

7.2 Cleaning and maintenance of heater H2O / boiler Compact

.....

7.3 Patented self-cleaning burner.

.....

8. SMOKE DISCHARGE TUBE AND COMBUSTION AIR INTAKE

.....

8.1 Ventilation of the rooms

.....

8.2 Combustion air intake

.....

8.3 Smoke outlet

.....

9. ALARMS ..

.....

10. ELECTRICAL WIRING

.....

.....

11. INFORMATION FOR THE SKILLED TECHNICIAN

.....
11.1 Main components and their operation

.....
11.2 Useful advice for installation and operation

.....
11.3 Troubleshooting cause - solution

12. SPARE PARTS

.....
.....



THERMOROSSI S.p.A.

Via Grumolo, 4
36011 ARSIERO
tel. 0445.741310
fax 0445.741657

“CE” DECLARATION OF CONFORMITY

In accordance with the following directives:

European Directive	73/23/EEC and its amending directive	93/68/EEC
	89/336/EEC and its amending directives	93/68/EEC 92/31/EEC 93/97/EEC

Thermorossi S.p.A., Via Grumolo 4 - ARSIERO (VI), declares that the heater H2O and the boiler Compact have been designed and manufactured in compliance with the safety requirements of the standards for EC marking.
This declaration refers to the entire range of the specified series.

ARSIERO , 5th June 2007

THERMOROSSI S.p.A.

1 INTRODUCTION

1.1 GENERAL GUIDELINES

This installation, use and maintenance guide is an integral and essential part of the product and must be kept by the user. Before commencing with the installation, use and maintenance of the product, carefully read all the instructions contained in this booklet. At the time of installation of the appliance all local regulations, including those that refer to national and European regulations, must be observed. The Manufacturer highly recommends carrying out all the maintenance operations described in this manual. This appliance must only be used for its intended purpose. Any other use is considered incorrect and therefore hazardous; consequently, the user shall be totally liable for the product if used improperly. Installation, maintenance and repairs must be carried out by personnel with professional qualifications and in compliance with current regulatory standards and in accordance with the instructions of the manufacturer of the appliance. Use only original spare parts.

Incorrect installation or poor maintenance could injure or damage people, animals or things; in this case the manufacturer shall be relieved of all responsibility. Before commencing any cleaning or maintenance operation ensure that the appliance has been disconnected from the mains power supply by means of the main system switch or some other disconnecting device installed upstream from the appliance. The product must be installed in locations suitable for fire-fighting and furnished with all the services (power and outlets) which the appliance requires for a correct and safe operation. Any repairs or actions carried out on any systems, components or internal parts of the appliance, or on any of the accessories supplied with it, that are not specifically authorised by Thermorossi s.p.a, will automatically void the warranty and the manufacturer's responsibility, pursuant to D.P.R. 224 of 24/05/1988, art. 6/b. Use only original Thermorossi spare parts. If the appliance is sold or transferred to another user ensure that the guide is handed over with it.

Thermorossi S.p.A. maintains the author's rights on these service instructions. The information in this booklet may not be reproduced or given to third parties or used for competitive purposes without the appropriate authorization.

1.2 SAFETY GUIDELINES



PERSONAL INJURY

This safety symbol identifies important messages throughout the manual. Read the information marked by this symbol carefully as non-observance of this message can cause serious injury to persons using the heater/boiler.



DAMAGE TO PROPERTY

This safety symbol identifies messages or instructions that are fundamental for the heater/boiler and system to function well. Failure to observe these symbols could result in serious damage to the heater/boiler and system.



INFORMATION

This safety symbol signals instructions that are important for the good operation of the heater / boiler or heating system. The appliances will not function correctly if the instructions are not observed correctly.

1.3 STANDARDS AND RECOMMENDATIONS

NORMATIVE REFERENCES :national and international standards used as reference guides for the design, industrialization and production of the products:

- European Directive 73/23/EEC
- European Directive 93/68/EEC
- European Directive 89/336/EEC
- standard CEI 61/50
- standard CEI EN 60204
- standard CEI 64-8 (IEC 364)



RECOMMENDATIONS

Before using the appliance, carefully read every section of this instruction manual as knowledge of the information and the regulations contained in it are essential for a correct use of the appliance.

The entire operation concerning the connection of the electric panel must be carried out by expert personnel; no responsibility will be accepted for damages, even to third parties, if the instructions for installation, use and maintenance of the appliance are not followed scrupulously. Modifications made to the appliance by the user or on his behalf, must be considered to be under his complete responsibility. The user is responsible for all the operations required for the installation and maintenance of the appliance before and during its use.

GENERAL WARNINGS



Caution: the appliance must be connected to a system provided with a PE conductor (in compliance with the specifications of 73/23/EEC, 93/98/EEC, concerning low voltage equipment).

Before installing the appliance check the efficiency of the earth circuit of the power supply system.

Caution: the power supply line must have a section which is suitable for the power of the equipment. The cable section must in any case be no less than 1.5 mm². The appliance must be powered with a voltage of 220/240 V and 50 Hz. Voltage variations which exceed 10% of the nominal value can cause poor functioning or damage the electrical device. Position the appliance so that the electric power plug is easily accessible. Voltage variations less than 10% of the nominal value can cause lighting and use problems. Apply a current regulator.

Ensure that a suitable differential switch is installed upstream from the equipment.

1.4 TRANSPORTATION AND STORAGE

TRANSPORTATION AND HANDLING The boiler body must always be in a vertical position when handled and exclusively by means of trolleys. Take special care to protect the electric panel, the glass, the ceramics and all the fragile parts from mechanical impact which could damage them and their correct functioning.

STORAGE : The heater / boiler must be stored in a humid-free environment and sheltered from the weather; do not place the heater / boiler directly on the floor. The Company denies all responsibility for damage caused to wood floors or floors made from any other material. It is inadvisable to store the heater / boiler for long periods of time.

2 TECHNICAL CHARACTERISTICS *

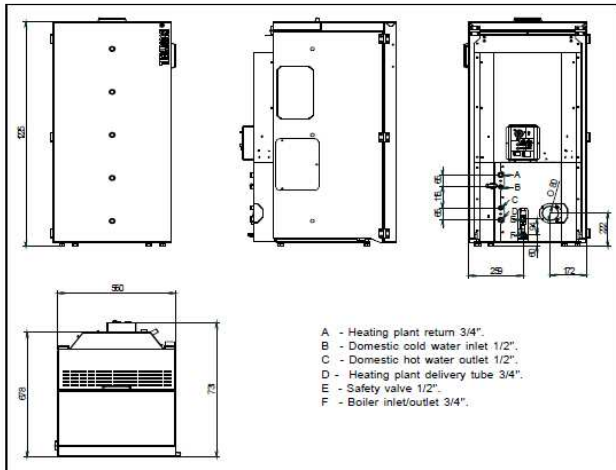
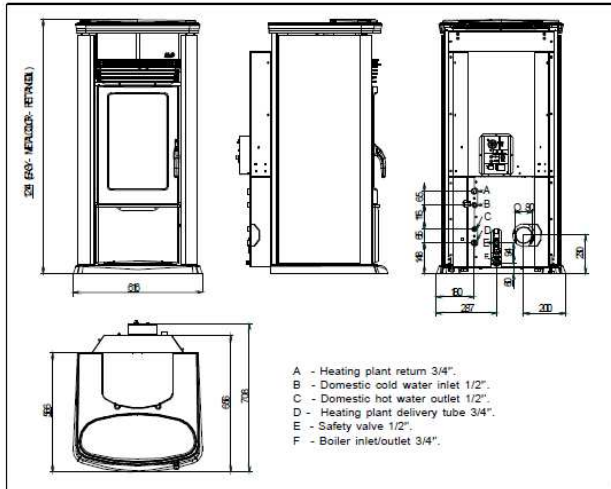

	<i>ECO</i>	<i>Compact</i>
Height (mm)	1214	1225
Depth (mm)	708	731
Width (mm)	616	560
Weight (Kg)	209 / 235	206
D. smoke outlet (mm)	80	80
Min. draft (mbar)	-0,10	-0,10
Thermal power at the firebox (kW)	3,1 - 18	3,1 - 18
Thermal power output air (kW)	2,5	0,5
Thermal power output water (kW)	12,5	14,5
% yield	up to 90%	up to 90%
Min/max consumption (Kg/h)	0,8 - 3,5	0,8 - 3,5
Hopper capacity (Kg)	43	43
Working pressure	1 bar	1 bar
Water content (l)	36	36
Electricity	220 V 50 HZ	220 V 50 HZ
Max electrical consumption	1,74 A - 383 W	1,74 A - 383 W
Average electrical consumption	0,77 A - 169 W	0,77 A - 169 W
A heating plant return	3/4"	3/4"
F boiler inlet/outlet	3/4"	3/4"
E safety valve	1/2"	1/2"
D heating plant delivery tube	3/4"	3/4"
B domestic cold water inlet (optional)	1/2"	1/2"
C domestic hot water outlet (optional)	1/2"	1/2"
domestic hot water max volume (optional)	approx. 5.5 l/min *	approx. 5.5 l/min *

* The volume of domestic hot water refers to max combustion power and temperature of water flowing into the heat exchanger at 20 °C and water flowing out of the heat exchanger at 60 °C.

CHARACTERISTIC CURVES OF SINGLE-PHASE PUMP

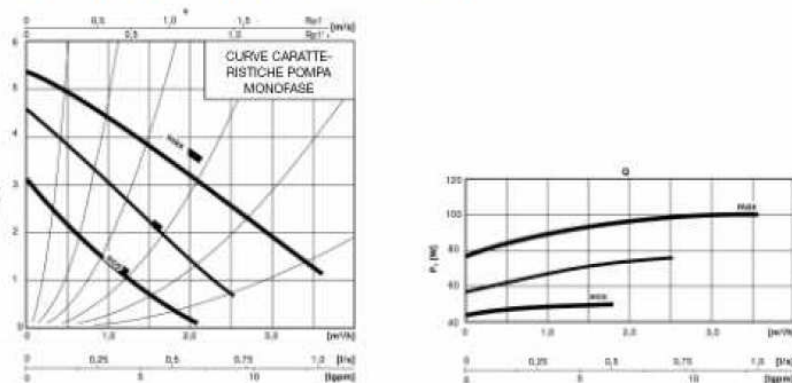

* All the data are based on the appliance fuelled with Austrian standard ÖNORM M 7135 type-approved pellets.

3 GENERAL DESCRIPTION

3.1 OPERATING TECHNOLOGY

Your heater / boiler has been constructed to satisfy in full all your heating and practical needs. Top-grade components and functions managed with microprocessor technology guarantee high reliability and optimal performance.

3.2 PELLETS

The appliance is fuelled by pellets, that is, cylinders of compressed sawdust; this will make it possible for you to enjoy to the full the heat of the flame thermal value 4000/4500 Kcal/Kg and density of approx. 620-630 Kg/m³.

⚠ The use of fuel which does not comply with the description given above immediately voids the heater / boiler warranty. Do not use the appliance as an incinerator, at the risk of voiding the warranty.

3.3 THE FEEDBOX

i The feedbox is situated in the top part of the heater / boiler. The maximum load capacity of the tank is approximately 43 Kg, but varies according to the specific weight of the pellets.

! The manufacturer recommends emptying the hopper and vacuuming the screw feeder zone once a month and during the summer period. Take special care when loading the hopper as the screw feeder at its base is in motion.

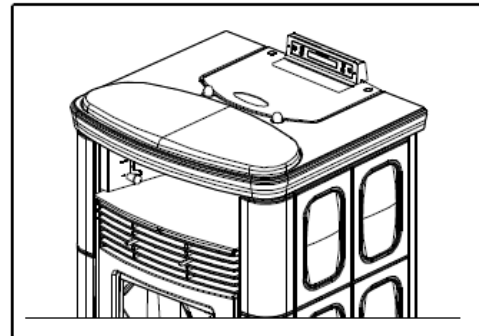

3.4 MAIN COMPONENTS OF HEATER MOD. H20 AND BOILER MOD. COMPACT

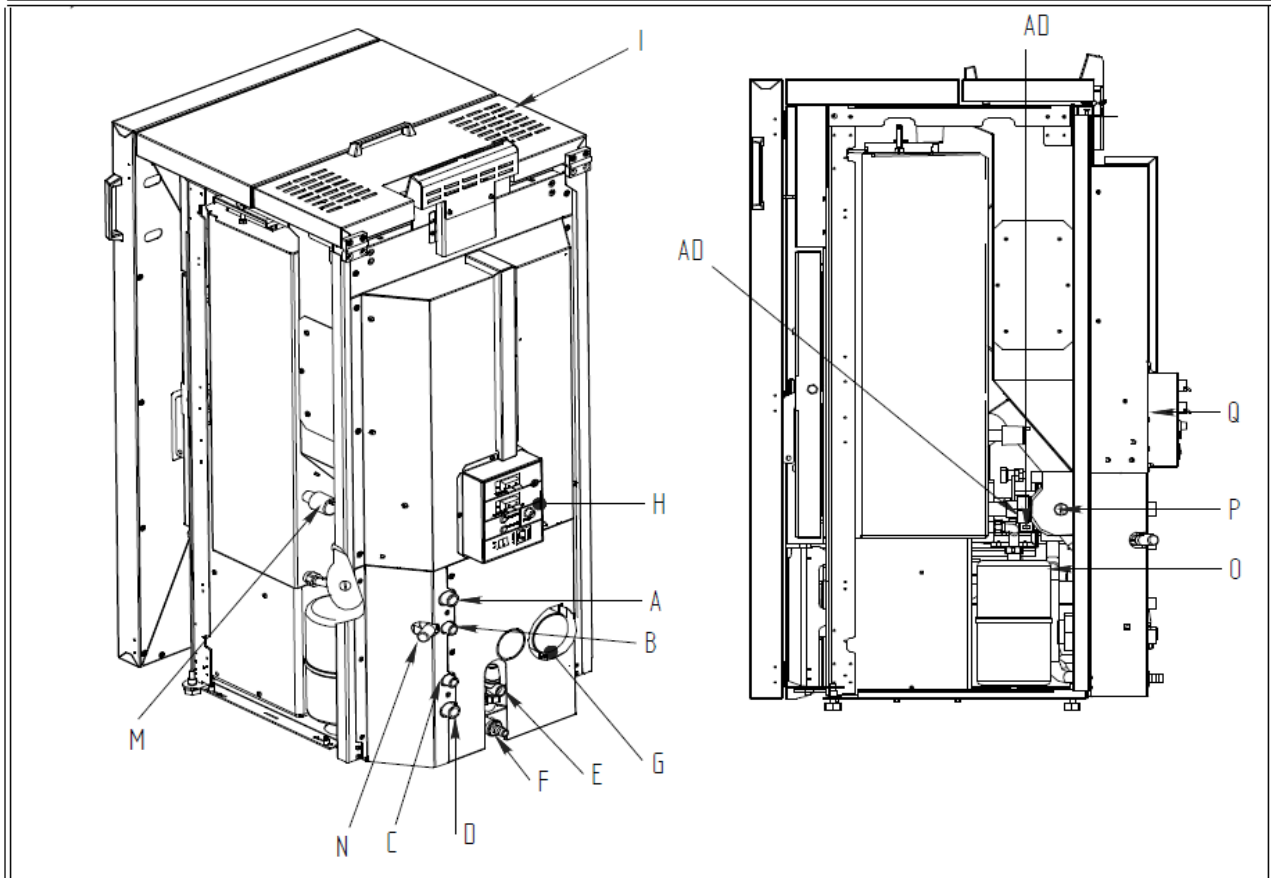

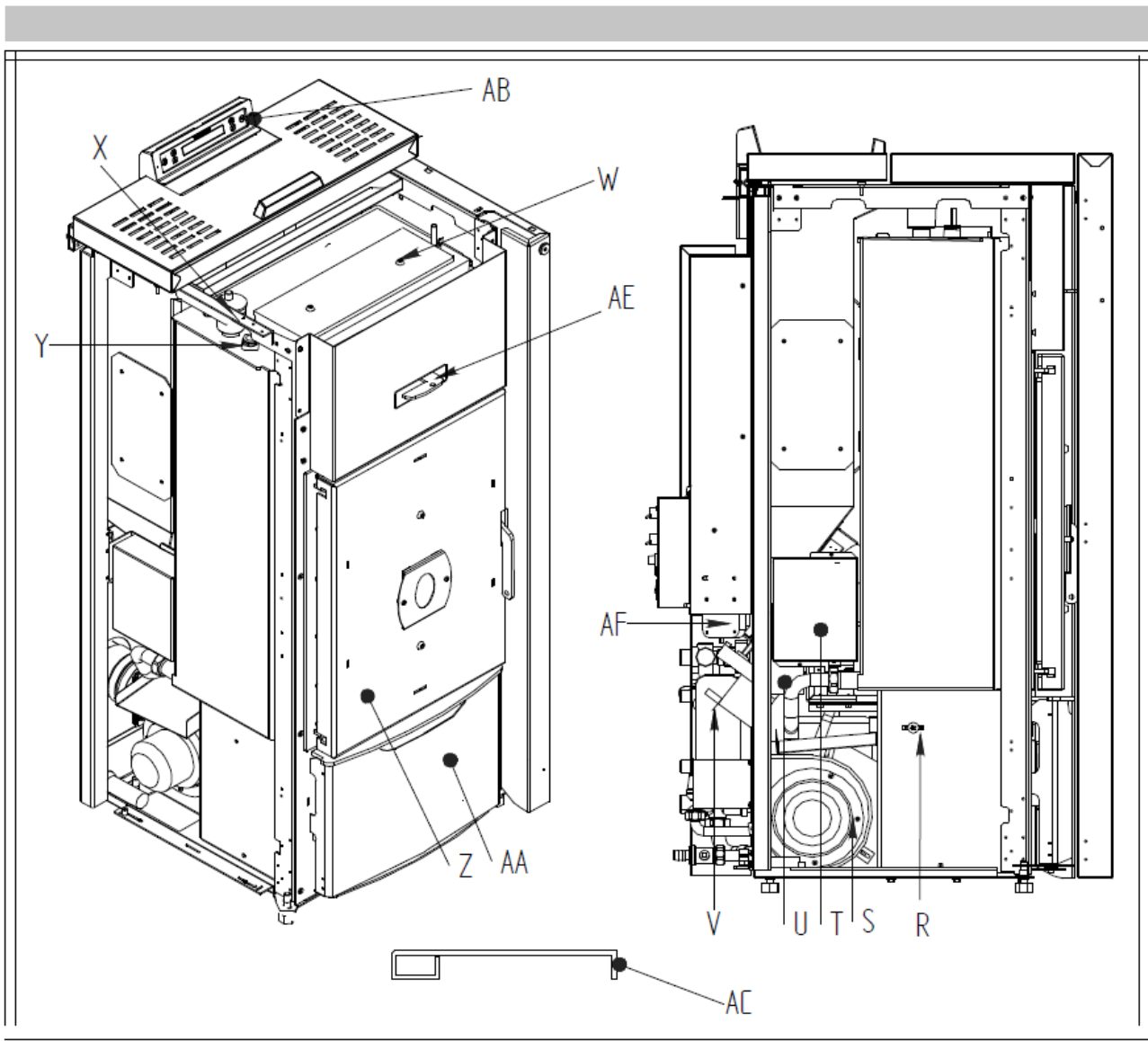

A: Heating plant return
B: Domestic cold water inlet 1/2".
 (only with Domestic Water Kit - optional -)
C: Domestic hot water outlet 1/2".
 (only with Domestic Water Kit - optional -)
D: Heating plant delivery tube 3/4".
E: Safety valve 3 bar 1/2".
F: Boiler Inlet - Outlet 3/4".
G: Smoke exhaust pipe

H: Safety thermostat 100°C.
I: Pellet hopper .
M: Pressure transducer.
N: System Inlet
 (only with Domestic Water Kit - optional -)
O: Expansion tank 2.5 l for protection of
 the boiler only.
P: System circulating pump.

Q: Back panel of heater.
R: Thermostat 42°C.
S: Smoke suction unit
T: Electronic power board.
U: Burner cleaning motor
V: Pellet loading motor.
W: Tube bundle inspection cover.
X: Automatic relief valve.
Y: Pocket for heating system PTC sensor
 and thermostat bulb 100°C reset.
Z: Patented burner.
AA: Ash pan.
AC: Riddling tool.
AD: Spark plug.
AE: Spiral tube scraper.
AF: Smoke side pressure switch.
AB: top display

4 INSTALLATION

4.1 HEATER / BOILER LOCATION

CAUTION : Always use trolleys to move the appliance and the appliance must always be in a vertical position. The casing for the H2O is packed separately. On the contrary, to unpack the Compact, once the wood crate has been removed, remove the casing (in reverse order as set out in para.4.2.3). Remove the screws at the base of the heater / boiler and remove the base from the bottom pallet. Follow the general guidelines set out in paragraph 1.1 to the letter. Above all ensure that the flooring of the room where the heater / boiler will be installed is capable of bearing the weight of the appliance plus the weight of the water contained in it and the weight of the pellets in the hopper.

CAUTION: The room in which the appliance will operate must be adequately ventilated (minimum air intake for an air flow of 1300 m³/h).

The heater / boiler must be positioned at a minimum safe distance from walls and furnishings. This distance will have to be increased considerably if the objects surrounding the appliance are inflammable (matchboarding, furniture, curtains, picture frames, sofas, etc...). The recommended minimum distances are illustrated in the drawing below on the right. Installation in the vicinity of heat-sensitive materials is only permitted if suitable insulating protection is provided (ref. Uni 10683).

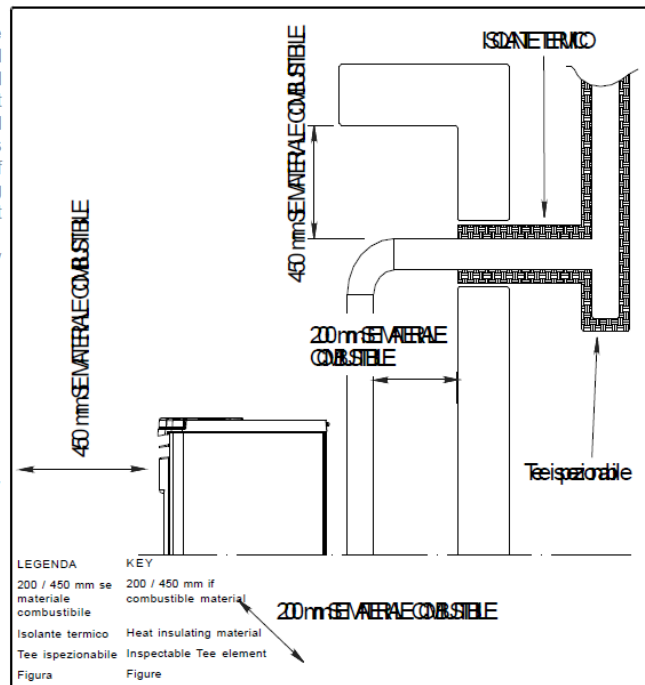

4.2 MOUNTING HEATER / BOILER CASING.

4.2 MOUNTING HEATER / BOILER CASING.

4.2.1 MOUNTING METALCOLOR / EASYCASING FOR HEATER H2O

After positioning and levelling the heater by raising or lowering the mounting feet, connecting it to the heating system and to the electrical system (see par.4.4 , 4.5 , 4.6 , 4.7 , 4.8 , 4.9 , 4.10, 4.11), proceed to mount the casing as illustrated:

Carry out the procedure described below and follow the drawing on the next page:

- Remove the cover (A) .
- Open the cover(D) , remove the screw (C) and remove the cover (E) .
- Fasten the 4 spacers (I) with the supplied nuts M4 (H) and screws M4x16 (L) to the lower base.
- Adjust the heater mounting feet and position the kickplates (M) as illustrated, making sure that the kickplates are inserted under the plate (PT); then check that the door can be easily removed (PC) and if necessary raise the feet.
- Mount the side panels by firstly inserting the lower holes on the spacers (I) that were fastened beforehand.
- Fasten the screws (F) to lock the side panels (G) .
- Mount the cast iron cover (E) , the cover (A) and fasten the screw (C) .

The casing on the EASY model is factory-mounted before being packaged. To move the heater from the pallet the casing and the 2 screws that secure the heater to the wood pallet must firstly be removed.

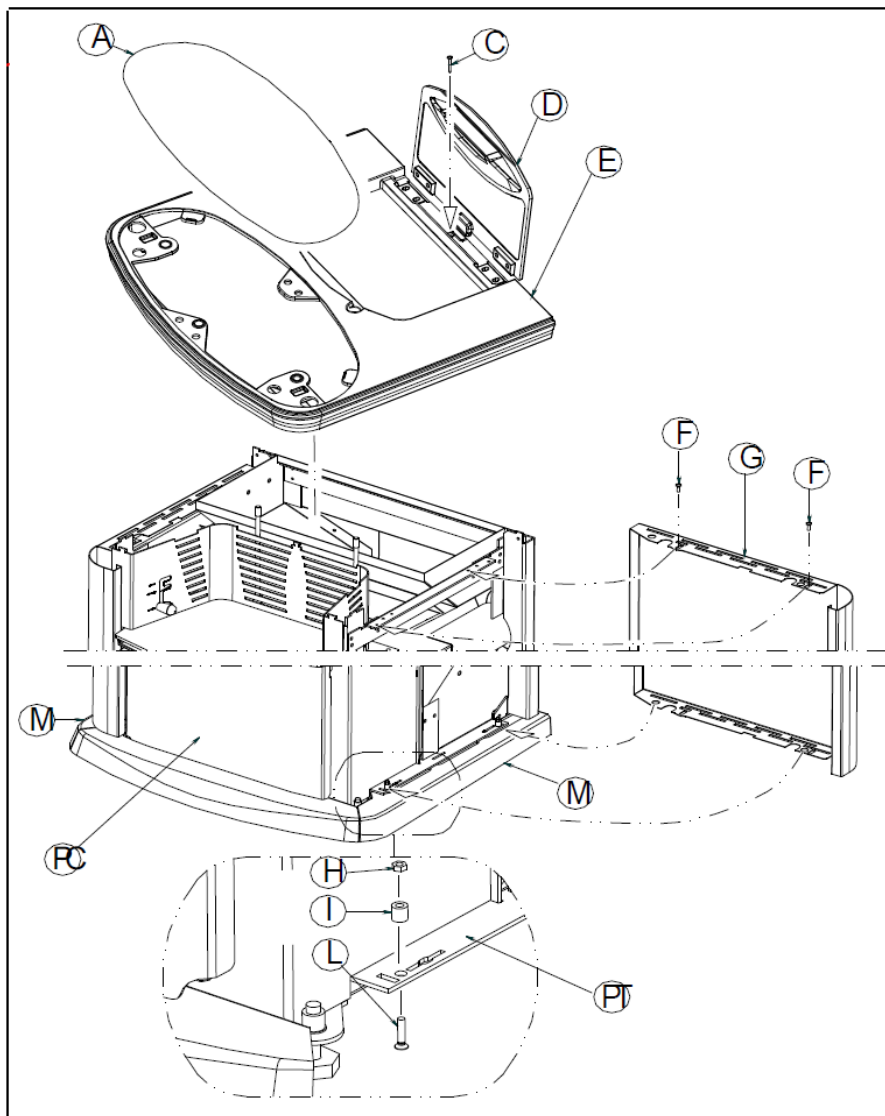

4.2.2 MOUNTING RECTANGULAR CERAMIC TILE CASING FOR HEATER H20.

After positioning and levelling the heater by raising or lowering the mounting feet, connecting it to the heating system and to the electrical system (see par.4.4 , 4.5 , 4.6 , 4.7 , 4.8 , 4.9 , 4.10 , 4.11), proceed to mount the casing as illustrated:

-Open the cover (D) and undo and remove the screw (C), then remove the cover (E) (figure 1).

Unpack the ceramic casing then proceed to secure the flat ceramic tiles with rectangular decor (CP) and the convex ceramic tiles (CT) to the steel backing plates (SA) :

-Fasten the steel backing plates to each other using the screws M4x12 (O), the washers d.4 (P), the nuts M4 (Q) (see figure 2). Place the elements on a flat surface (e.g. a table) to secure them and make sure that the edges match up (see detail figure 2)

-Next fasten the flat tiles to the steel backing plate using the screws M3 x 6 (R) and washers d.3 (S) provided (see figure 3): to carry out this operation place the flat tiles on a table and lay the steel backing plate (SA) on top, then fasten them with screws and washers. Handle the ceramic tiles with extreme care to prevent accidental breakages.

-Then secure the convex ceramics to the steel backing plate with the screws M3 x 6 (R) and washers d.3 (S) (see figure 3): to carry out this operation fasten the ceramics to the steel support (SA) with screws and washers as illustrated in figure 4 and adjust their alignment with the flat ceramics. Handle the ceramic tiles with extreme care to prevent accidental breakages.

-Do not tighten the screws M3X6 (R) excessively as this could damage the ceramic tiles; this damage is not covered by warranty.

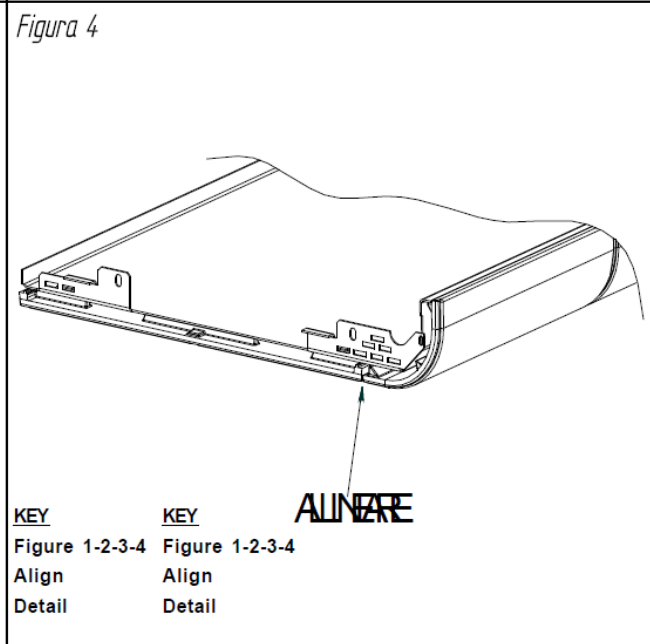
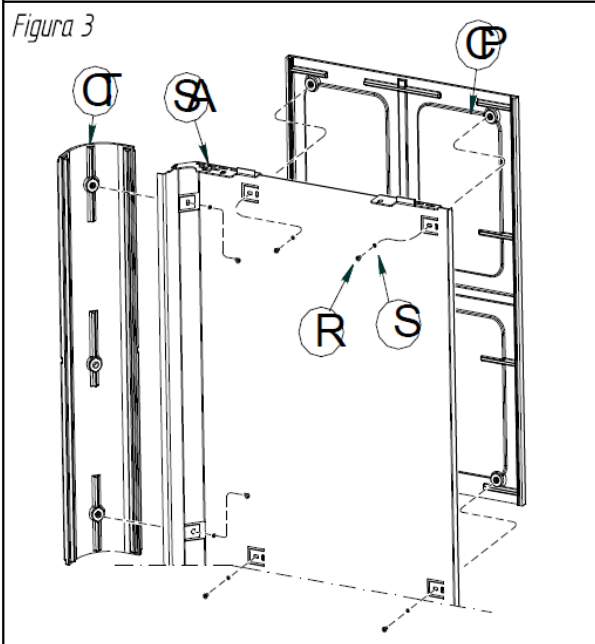
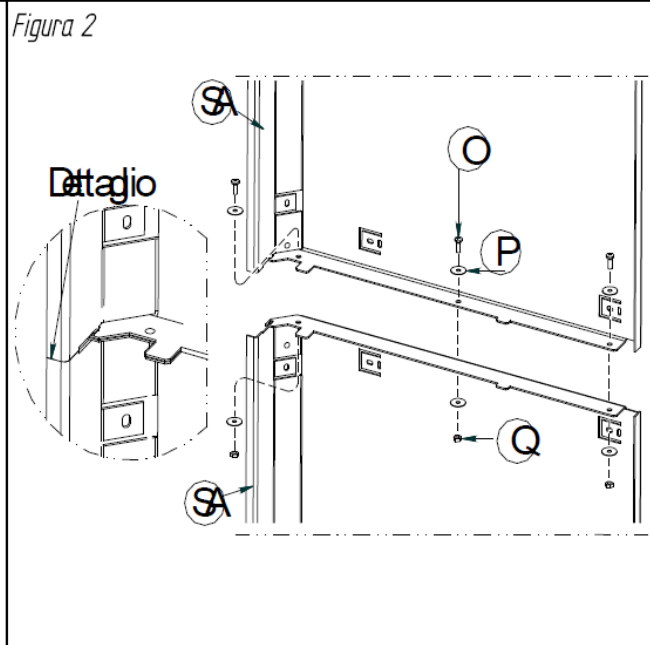
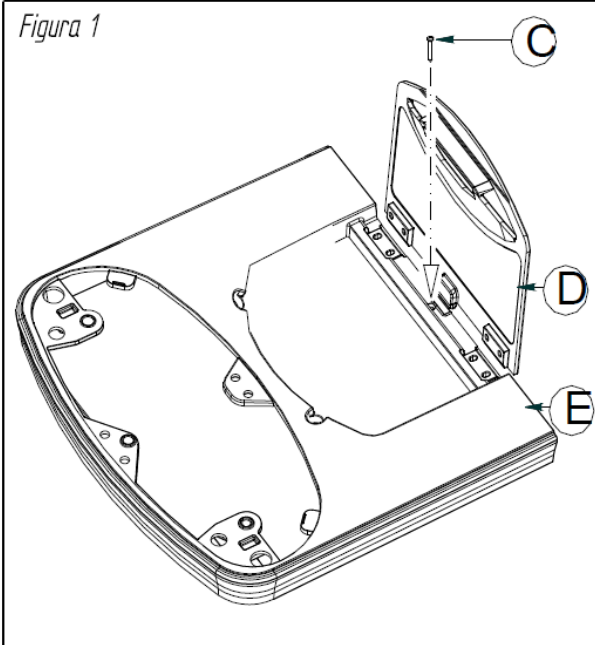

- Adjust the heater mounting feet.
- Position the kickplates (M) (figure 5 and figure 6), then check that the door (PC) can be removed and if necessary raise the mounting feet, mount the side with ceramic tiles by firstly inserting the bottom folds on the base and fastening with the 2 screws (F) at the top.
- Next mount the cover (E) and secure it with the screw (C) (figure 1) .
- Lastly position the ceramic top.

It is important to take special care when mounting the ceramic side panels (CP) and the sheet metal support (SA) in order to prevent irregular bending which could cause breakages not covered by warranty.

Small imperfections on the surfaces of the ceramics such as: dimples, shivering and slight colour variations are normal characteristics of handcrafted ceramics which make each piece unique. Remove any stickers from the brass bushes to facilitate screwing in the screws M3.

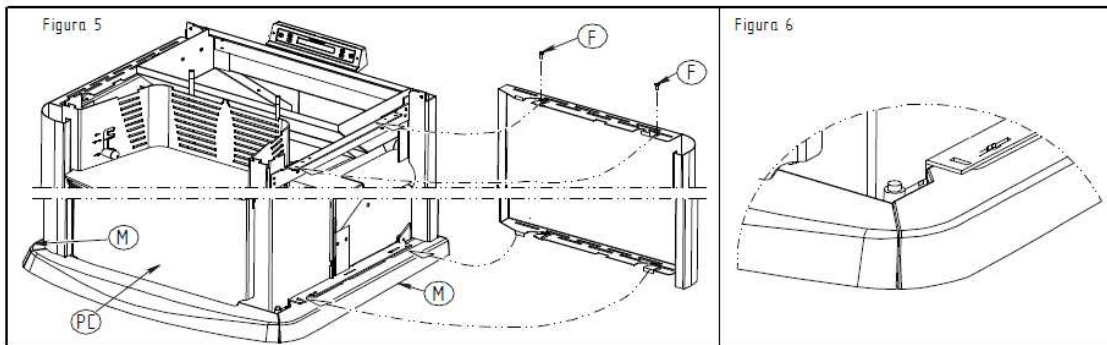

4.2.3 HOW TO MOUNT THE COMPACT BOILER CASING

After positioning and levelling the boiler by raising or lowering the mounting feet, connecting it to the heating system and to the electrical system (see par.4.4 , 4.5 , 4.6 , 4.7 , 4.8 , 4.9 , 4.10, 4.11), proceed to mount the casing as illustrated below:

- Firstly remove the protective film from the casing.
- Next mount the 2 side panels (F) by inserting the 2 holes of the bottom fold on the pins of the base and fastening the 2 top screws with a screwdriver.
- Fasten the front cover (C) by fitting it onto the side panels.
- Fasten the door (P) to the left side with the special hinges and screws provided.
- Lastly fit the back cover (CP) on the front cover (C) and fasten the hinges with the screws provided.

If you prefer the door (P) can be mounted with the handle on the left and the hinges on the right. Simply remove the handle (M) from the door and fix it to the holes on the left side of the door, remove the 3 hinges (T) and fix them to the right side of the door. Similarly, remove the magnet from the right side of the door and mount it on the left side of the door.

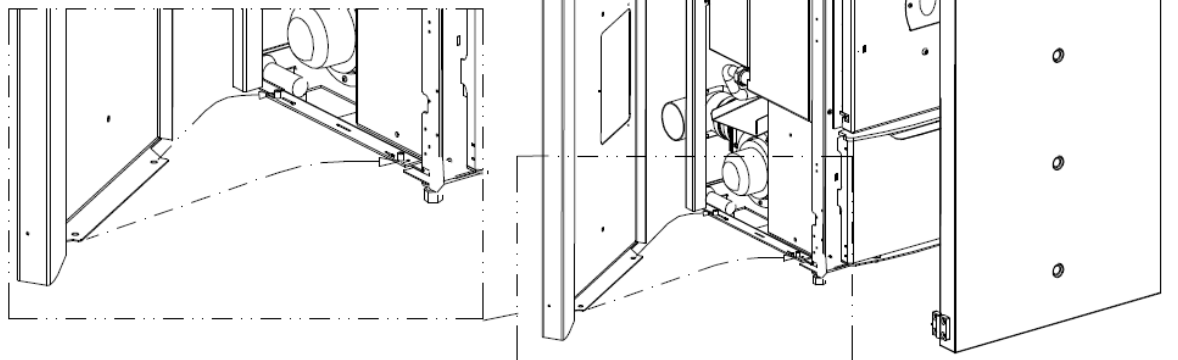

4.2.4 HOW TO INSTALL ADDITIONAL HOPPER (OPTIONAL) WITH COMPACT BOILER.

To increase the boiler's autonomy of operation it is possible to install one or two additional hoppers at the sides of the boiler. Each additional hopper can hold up to 100 Kg of pellets.

Firstly unpack the hopper then assemble it as follows:

- Fasten the 4 telescopic legs (A) using the screws provided (screws TSP+ 8x50).
- Fasten the pellet chute (attention: use chute B1) to the hopper using the screws provided (screws TC+4.8x13).
- Mount the panel (C) by inserting the bottom folds on the holes of the hopper, and then securing it using the screws provided (screws TC+4.8x13).
- Similarly fasten the panel (E) using the screws provided (screws TC+4.8x13).
- Then mount the panel (D) by lining up the lower rectangular holes on the panel folds (E) and fastening them using the screws provided (screws TC+4.8x13).
- The panels (D) and (E) can be mounted either to the right or to the left of the pellet chute (B1); if mounted on the right the additional hopper will have to be mounted to the right of the boiler.
- Fix the panel (G) by firstly inserting the holes on the bottom on the mounting feet then securing them with the screws provided (screws TC+4.8x13).
- Next mount the panel (F) by inserting the bottom folds on the holes in the panel (G).

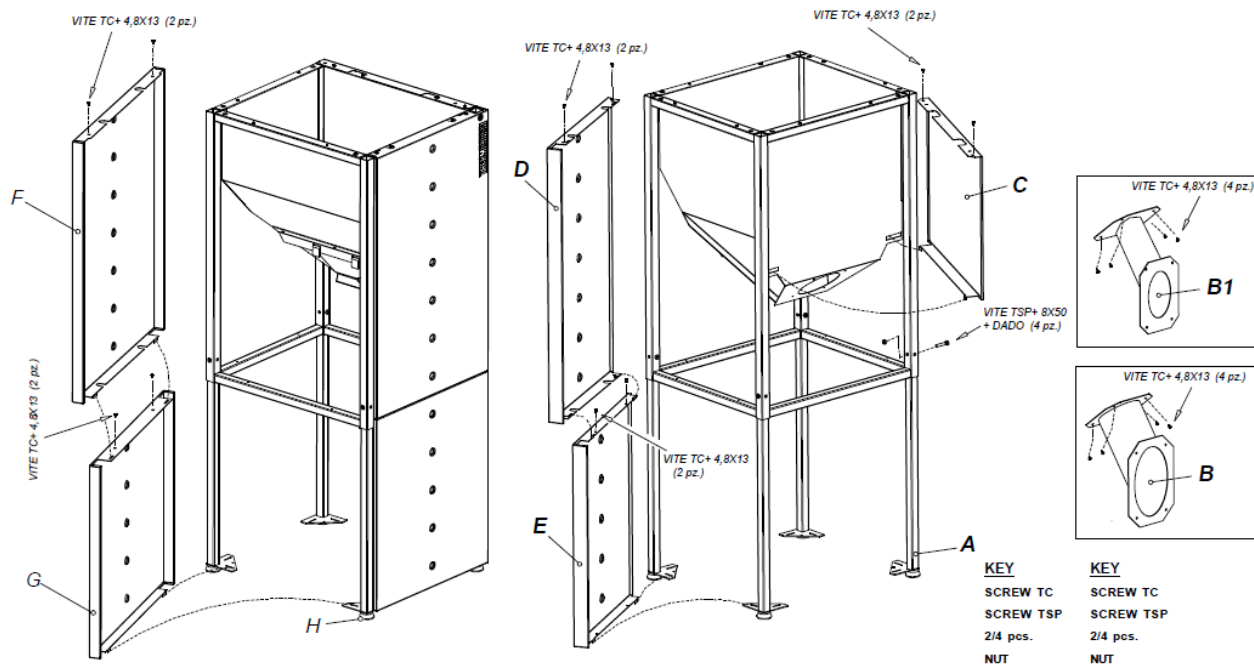

4.2.5 HOW TO FASTEN THE ADDITIONAL HOPPER (OPTIONAL) TO COMPACT BOILER.

After having mounted the additional hopper fasten the hopper to the boiler:

- Remove the octagonal portion of precut sheet metal from the side (F) of the boiler
- Remove the cap (I) from the hopper by undoing the screws fastened to it.
- Move the additional tank up against the boiler by adjusting the mounting feet (H) until the assembly is satisfactory.
- Fasten the assembly using the screws previously removed from the cap (I).

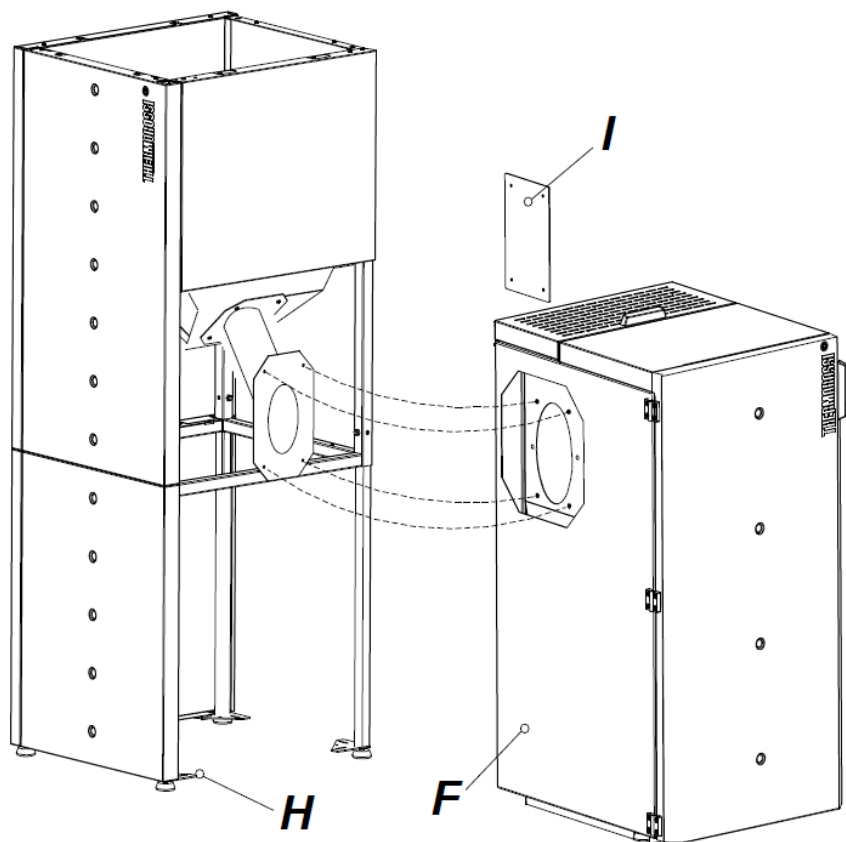

4.3 HYDRAULIC DRAWING FOR HEATER H₂O / COMPACT

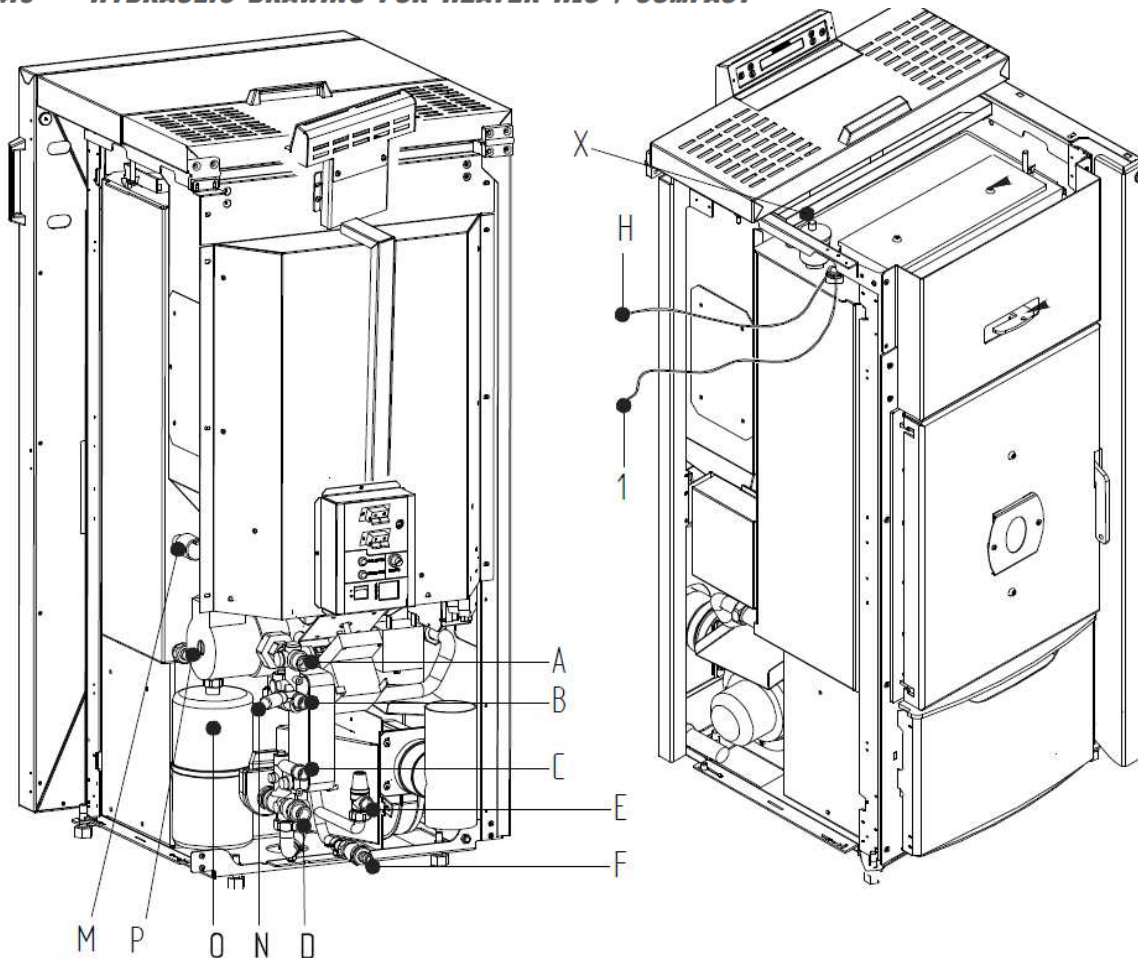

- | | |
|--|--|
| A : Heating plant return | B : Domestic cold water inlet 1/2". (only with Domestic Water Kit - optional -) |
| C : Domestic hot water outlet 1/2". (only with Domestic Water Kit - optional -) | D : Heating plant delivery tube 3/4". |
| E : Safety valve 3 bar 1/2". | F : Boiler Inlet - Outlet 3/4". (only with Domestic Water Kit - optional -) |
| H : Safety thermostat 100° C. | N : System Inlet |
| M : Pressure transducer. | P : System circulating pump. |
| O : Expansion tank 2.5 l for protection of the boiler only . | 1 : Boiler sensor |
| X : Automatic relief valve. | |



CAUTION: FOR THE DELIVERY, RETURN, MAKE-UP AND DISCHARGE CONNECTIONS USE FLEXIBLE TUBES HAVING A LENGTH OF AT LEAST 70 CM TO FACILITATE MOVING THE APPLIANCE FOR MAINTENANCE.
CAUTION: A CONNECTION MUST BE MADE BETWEEN THE SAFETY VALVE AND THE OUTLET TO PREVENT DAMAGING MATERIALS SURROUNDING THE BOILER/HEATER WHEN THE VALVE IS ACTIVATED.
 (SEE PAR. 4.4 - 4.5 - 4.6 - 4.7 - 4.8 - 4.9).

4.4 EXAMPLE OF HYDRAULIC DRAWING FOR H₂O / COMPACT ONLY HEATING .

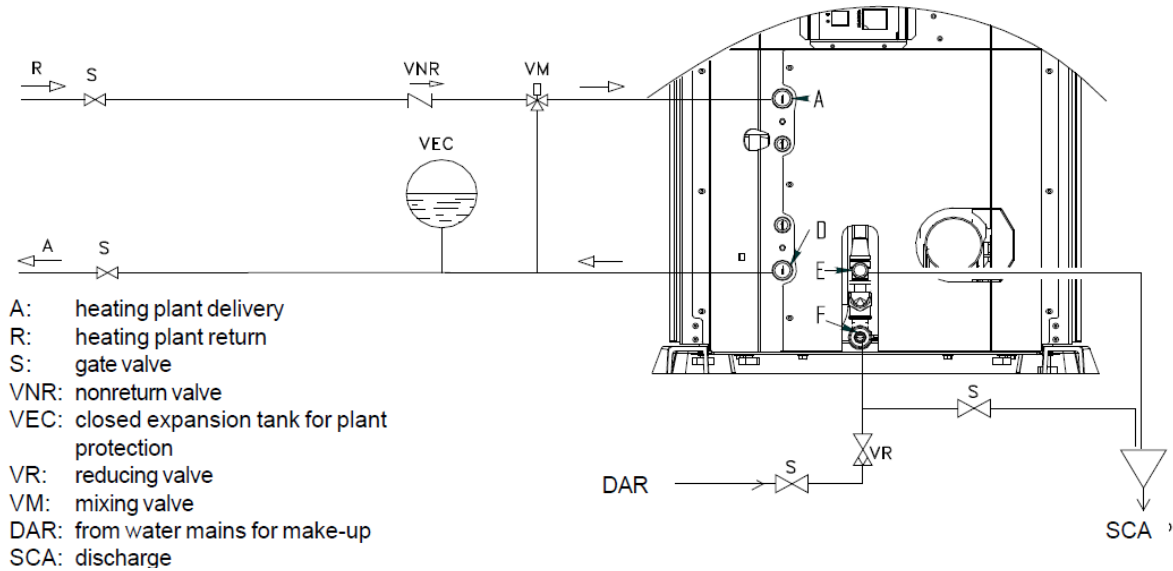

Caution: it is mandatory to earth the heater / boiler. If this instruction is not observed serious damage, which is not covered by warranty, will result to the body of the heater / boiler. Have an electrician check the earthing. There must be no electric potential (volts) between the earth of the generator and the actual earth of the plant. To prevent electrochemical corrosion of the boiler body do not use galvanised pipes and fittings. Dedicated ground wires must be used to ground all other materials.

4.5 EXAMPLE OF HYDRAULIC DRAWING FOR H₂O / COMPACT WITH AIRCASED BOILER TUBES

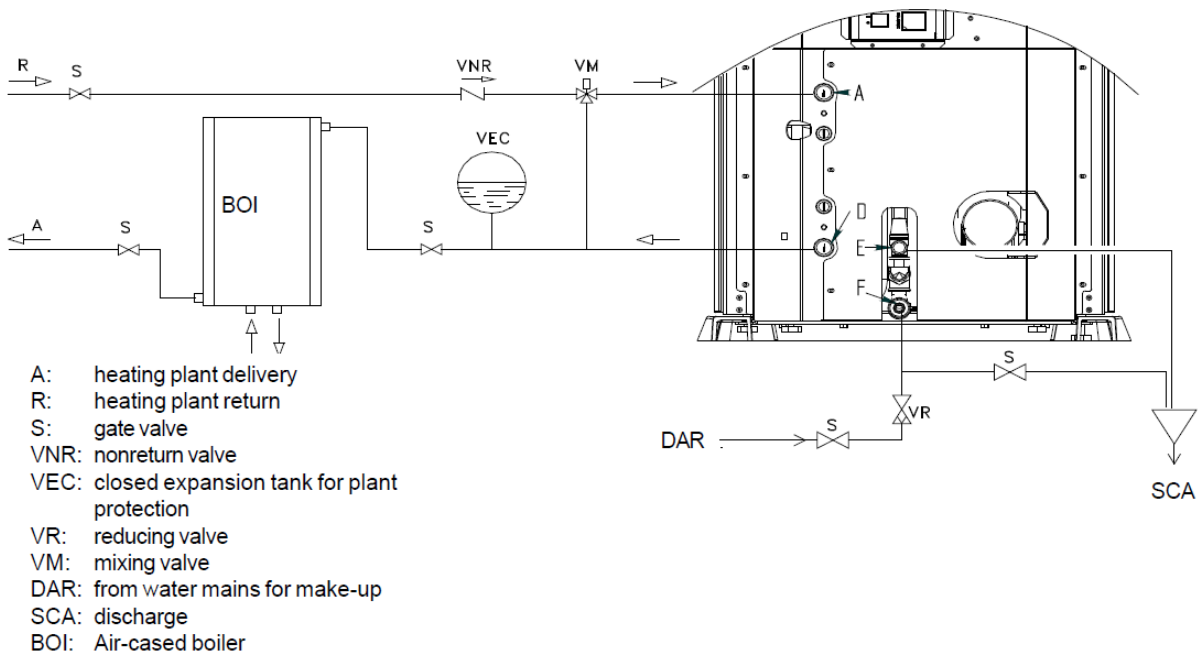

CAUTION : The water temperature in the boiler tubes in this case is not adjustable and depends on the systems's delivery temperature, that is the max temperature t setting.

Caution: it is mandatory to earth the heater / boiler. If this instruction is not observed serious damage, which is not covered by warranty, will result to the body of the heater / boiler. Have an electrician check the earthing. There must be no electric potential (volts) between the earth of the generator and the actual earth of the plant. To prevent electrochemical corrosion of the boiler body do not use galvanised pipes and fittings. Dedicated ground wires must be used to ground all other materials.

4.6 EXAMPLE OF HYDRAULIC DRAWING H₂O/COMPACT WITH BOILER COILS AND USE OF THERMOCONTROL (OPTIONAL)

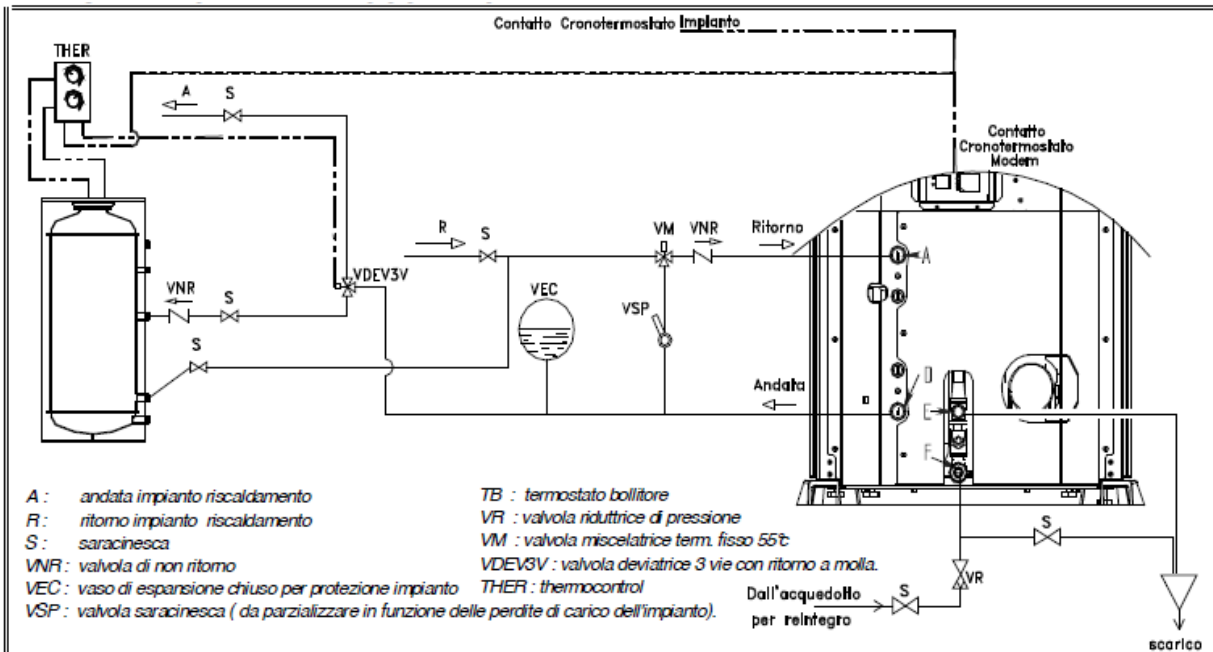

In order to guarantee correct absorption of the heat produced by the generator it is advisable to use a boiler tube with volume and heat exchange capacity suitable for the power of the generator.

Caution: it is mandatory to earth the heater / boiler. If this instruction is not observed serious damage, which is not covered by warranty, will result to the body of the heater / boiler. Have an electrician check the earthing. There must be no electric potential (volts) between the earth of the generator and the actual earth of the plant. To prevent electrochemical corrosion of the boiler body do not use galvanised pipes and fittings. Dedicated ground wires must be used to ground all other materials.

4.6.1 Thermocontrol electrical connection where the boiler is integrated in a plumbing system with boiler coils.

The following is a description of the electric wiring for Thermocontrol and H₂O 25 / Compact 25: through this electrical connection, the shut off action by Thermocontrol automatically switches the diverter valve and also switches off the boiler: if the system Chronothermostat requires more heat the boiler does not switch off until it has satisfied the heating requirements of the room. The connections to the diverter valve and system chronothermostat are shown in the diagram and in the following photos. **CAUTION:** in order to prevent too many boiler start ups, with consequent reduction in the electrical heater lifetime, the manufacturer highly recommends using a chronothermostat with a thermal hysteresis of at least 2°C.

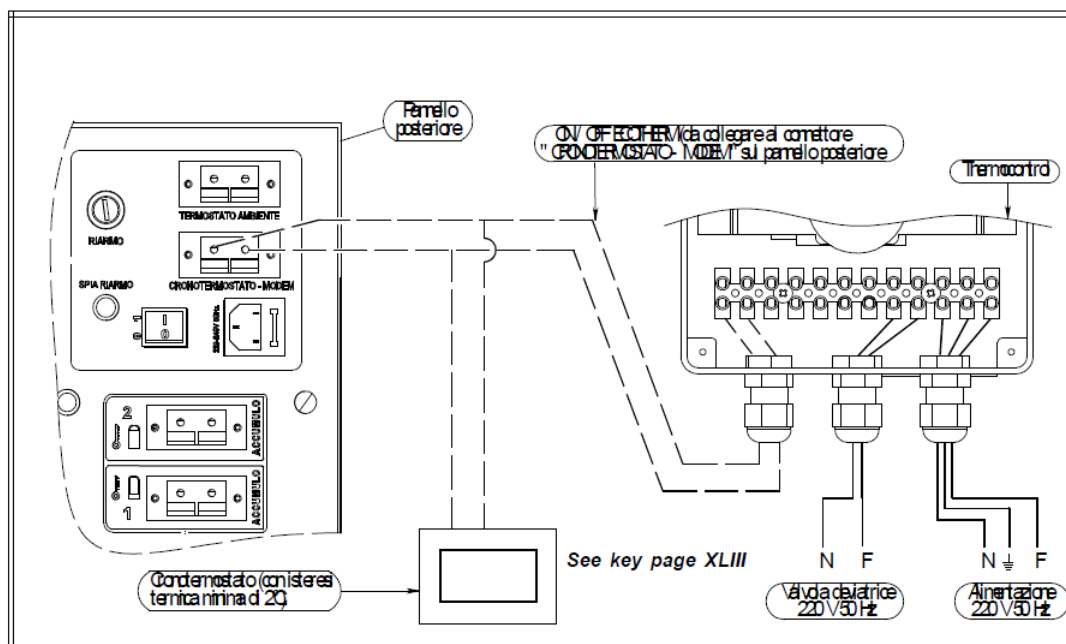

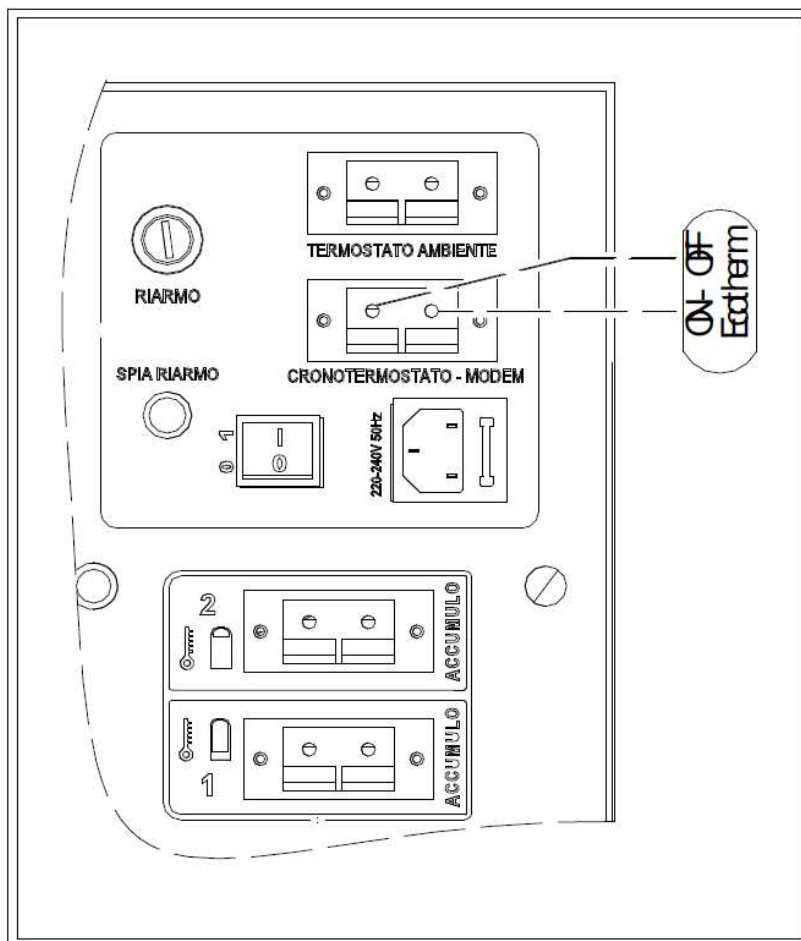
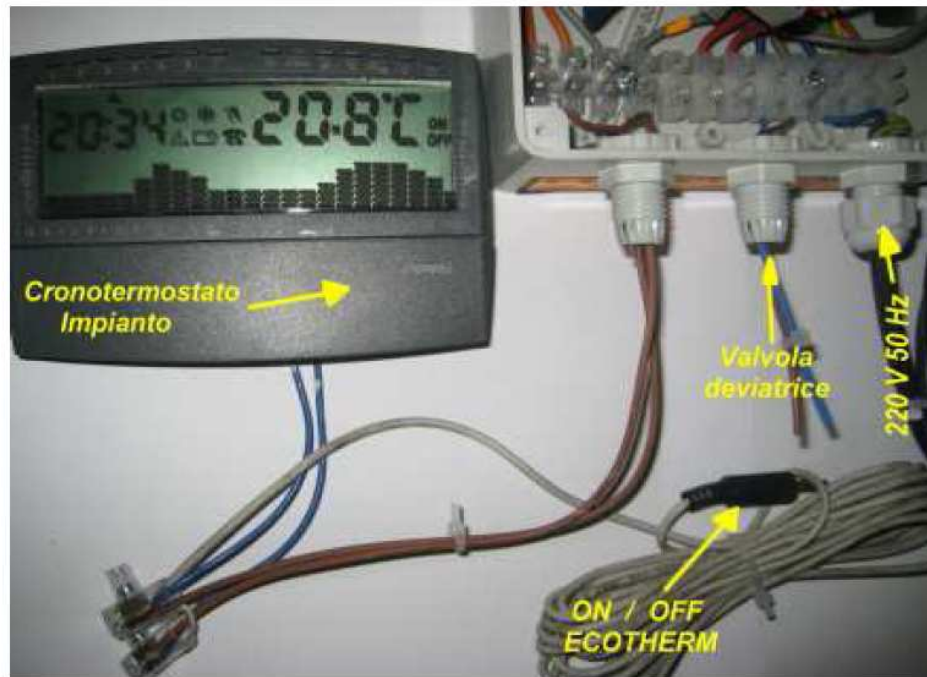

LEGENDA	KEY
ON - OFF - Ecotherm	ON - OFF - Ecotherm
Termostato ambiente	Room temperature thermostat
Cronotermostato - Modem	Chronothermostat - modem
Spia motor.	Motor. LED
Spia riarmo	Reset LED
riarmo	Reset
Cronotermostato impianto	System chronothermostat
Valvola deviatrice	Diverting valve
Dosatore di polifosfati	Polyphosphates metering device
Sali per resine	Salts for resins
Addolcitore	Water softener
Filtro	Filter
Dall'acquedotto	From water mains
Rubinetto di carico impianto riscaldamento	Heating system inlet tap
All'utenza	To the usage point
Scarico	Outlet

4.7 SCHEMATIC DRAWING OF TYPICAL HYDRAULIC CIRCUIT FOR H2O / COMPACT + THERMOCCELL (OR THERMOPUFFER) + ADDITIONAL THERMOPUFFER + HIGH TEMPERATURE HEATING AND LOW TEMPERATURE HEATING.

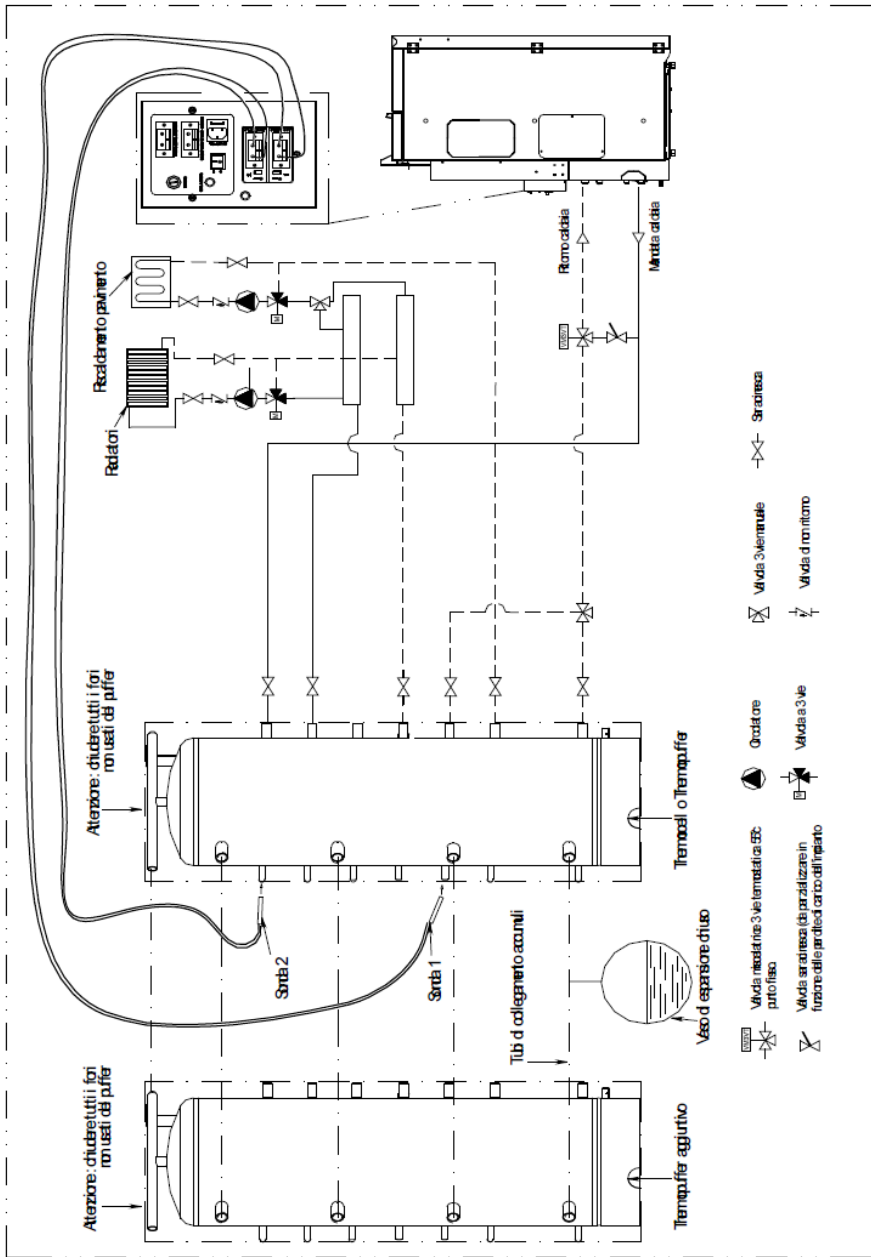

LEGENDA	KEY
Radiatori	Radiators
Riscaldamento pavimento	Underfloor heating
Attenzione: chiudere tutti i fori non usati del puffer	Caution: close all the holes not used by the puffer
Sonda 1 / 2	Sensor 1 / 2
Tubi di collegamento accumulati	Connection tubes to puffers
Thermopuffer aggiuntivo	Additional Thermopuffer
Vaso di espansione chiuso	Vaso di espansione chiuso
Thermocell o Thermopuffer	Thermocell or Thermopuffer
Mandata caldaia	Boiler delivery
Ritorno caldaia	Boiler return
Valvola miscelatrice 3 vie termostatica punto fisso	Three-way thermostatic mixing valve, fixed point
Circolatore	Circulating pump
Valvola 3 vie manuale	Manual three-way valve
Saracinesca	Gate valve
Valvola saracinesca (da parzializzare in funzione delle perdite di carico dell'impianto)	gate valve (throttle according to pressure drop in the system)
Valvola a 3 vie	Three-way valve
Valvola di non ritorno	Nonreturn valve

CAUTION: The system operating pressure must always be above the expansion tank preload: 2 bar for the expansion tank 1,5 bar.

CAUTION: The Thermocell must also be connected only to 220V - 50Hz power supply"; the adjustments of Sensor S1 and Sensor S2 must be controlled by the heater / boiler and not by the Thermocell electric panel. For this purpose connect 2 thermocouples (optional code no. 60010695) to the cable clamps of Sensor 1 and Sensor 2" of the generator.

CAUTION: Sensor S1 must be set at 65°C (over 65°C it switches off the boiler). Sensor S2 must be set at 40 - 45°C (under 40 - 45°C it switches on the boiler).

Caution: it is mandatory to earth the heater / boiler. If this instruction is not observed serious damage, which is not covered by warranty, will result to the body of the heater / boiler. Have an electrician check the earthing. There must be no electric potential (volts) between the earth of the generator and the actual earth of the plant. To prevent electrochemical corrosion of the boiler body do not use galvanised pipes and fittings. Dedicated ground wires must be used to ground all other materials .

4.7.1 CONNECTION OF SENSORS S1 AND S2 TO THE REAR PANEL OF THE HEATER / BOILER.

Sensor S2 and sensor S1 must be connected to the dedicated clamps on the rear panel (see para. 5.2). To activate the detections of Sensors S1 and S2 set THERMOCONTROL ON (see para. 5.8).

4.8 INSTRUCTIONS FOR EXECUTING THE HYDRAULIC SYSTEM CLOSED EXPANSION TANK.

Systems with closed expansion tank, must be provided with :

- | | |
|--|--|
| a) safety valve | b) thermal relief valve or thermal safety outlet (positive safety) |
| c) closed expansion tank | d) circulating pump activation thermostat (included in the panel of the central heating cooker). |
| e) acoustic alarm activation thermostat. | f) acoustic alarm |
| g) pressure gauge thermometer | h) circulation system |

These devices must be installed on the generator's delivery tube, within not more than 1 metre from the machine.

The **safety valve** must be connected to the highest part of the heat generator or the outlet tube, next to the generator. The length of the section of tube between the generator fitting and the safety valve must not be more than one metre. There must be no cocks that can cut off the tube connecting the safety valve to the heat generator and the section must not be less than the inlet section of the safety valve or the sum of the inlet sections if there are several valves that head a single tube, at any point whatsoever along its length. The outlet tube of the safety valve must be installed in such a way that it does not prevent the normal functioning of the valves and will not cause injury to persons ; the outlet must be located as close as possible to the safety valve and be accessible and visible. The diameter of the outlet tube must not in any case be less than the diameter of the safety valve outlet fitting. The outlet fitting diameter is the minimum internal diameter of the valve outlet upstream from any existing internal threading. The valve discharge pressure, equal to the calibration pressure and increased by the overpressure, must not exceed the maximum working pressure of the heat generator. The designer must ensure that the maximum pressure existing at every point of the system does not exceed the maximum working pressure of each of its components. The discharge capacity of the safety valve must be calculated according to the prescriptions set out in UNI 10412/2. The diameter of the minimum net cross section of the valve inlet must in any case be not less than 15 mm. **The maximum working pressure of the closed expansion tank** must not be less than the calibration pressure of the safety valve, plus the specific overpressure of the valve itself, with any difference in height between the tank and the valve taken into account, and the pressure generated by the functioning of the pump. The capacity of the expansion tank or tanks is evaluated according to the overall capacity of the plant as per the design. The closed expansion tanks must comply with current regulations governing pressure appliances in terms of design, construction, conformity assessment and utilization.



The rated volume of the closed expansion tank must be sized in relation to the expansion volume of the water in the system .

The heat generator must be connected directly to the plant's expansion tank or group of expansion tanks with a tube having an internal diameter no less than 18 mm. The connecting tube, which may consist of plant parts, must not be fitted with any shutoff cocks or have reduced sections. One three-way on-off valve may be installed for connecting the tank to the atmosphere for maintenance operations. This device must be protected against accidental manoeuvres. The connecting tube must be fitted in such a way that no scaling or deposit points are created. If several heat generators power a single system or secondary circuit, each heat generator must be connected directly to the system's expansion tank or group of expansion tanks sized overall for the total volume of water contained in the same plant or independent circuit. When it is necessary to separate the single heat generator from the expansion tank or group of expansion tanks, then a three-way tap having the same characteristics as those listed above must be installed on the tube that connects the generator to the expansion tank, in order to ensure that the generator is in any case connected either with the expansion tank or with the atmosphere in every position. The expansion tanks, connecting tubes, the vent and smoke exhaust pipes must be protected against freezing in areas where this could occur. The solution adopted for this purpose must be described in the project. Given that the circulation of the water in the heat generator must be maintained in any system and in all operating conditions within the limits prescribed by the supplier of the generator, in closed expansion tank heating systems, in which the circulation of the water is assured by means of an electric pump, the pump stopping must not cause, in any operating condition, the temperature to rise above the limit prescribed in these instructions.

The previous chapter does not replace UNI 10412/2 to which it makes reference . The qualified installer must in any case be fully aware of this standard and its amending versions.

4.9 MOUNTING THE KIT FOR THE PRODUCTION OF INSTANT DOMESTIC HOT WATER (OPTIONAL)

The heater H₂O / boiler Compact can be supplied with a "Kit for the production of instant domestic hot water" (see par. 4.7). When a tap is turned on, the "flow switch" commands the "diverting valve" to convey the hot water from the boiler to the plate heat exchanger.

The temperature of the domestic hot water obtained in this way is roughly 10° - 15° lower than the temperature in the boiler as indicated on the handheld radio control and in any case within the limits indicated in par. 2. **Hot water is not available when the boiler is switched off. When the boiler switched on, upon a request for hot water, it operates at the maximum steady state level of combustion: the diverting valve only conveys the water to the plate heat exchanger if the temperature in the boiler is above 61°.** The manufacturer recommends installing a water softener to ensure an optimal life of the plate heat exchanger (see par. 4.7). It is also advisable to regularly clean and check the plate heat exchanger. The Kit for the production of instant domestic hot water comprises:

- 2 Gaskets.
- 1 Hot water delivery tube to the heating system.
- 1 Flow switch cable.
- 1 Diverting valve cable.
- 1 Complete Unit, preassembled, consisting of a plate heat exchanger, heating system inlet tap, diverting valve, flow switch, brass delivery body, brass return body.
- 2 screws for fastening the unit.
- 1 complete locking band.

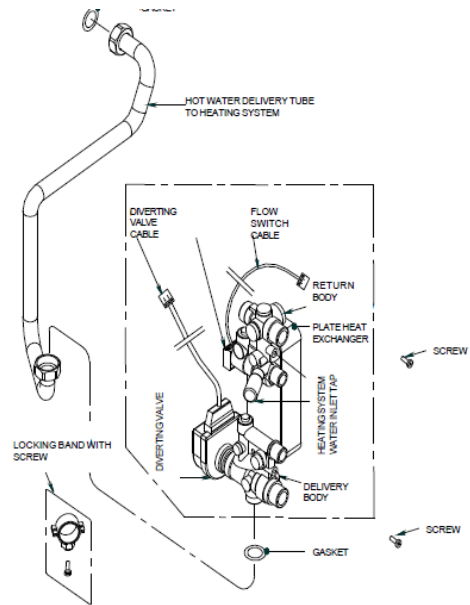

4.11.1 HYDRAULIC INSTALLATION FOR "KIT FOR THE PRODUCTION OF INSTANT DOMESTIC HOT WATER"

Installation of the "Kit for the production of instant domestic hot water" must be made as indicated below:

- Empty the boiler completely by acting on the "drain tap" and empty or shut off the system.
- Remove the ring nut from the "delivery tube to heating system (type 1)".
- Remove, by acting on the indicated screws, the "bottom back plate" and the "complete preassembled unit support".
- Next remove the "delivery tube to heating system (type 1)" fastened to the boiler.
- Fasten the "locking band" as indicated.
- Fasten the "delivery tube to heating system (type 2)" with the corresponding gasket.
- Connect the "complete preassembled unit" to the "delivery tube to heating system" and to the circulating pump of the boiler with the corresponding gaskets.
- Next fasten the "preassembled unit support" with the corresponding screws.
- Firmly fasten the "complete preassembled unit" with the "screws for mounting the complete preassembled unit" to the "complete preassembled unit support".
- Lastly fasten the "bottom back plate".
- Then make the hydraulic connections between the heater / boiler and the system and fill up with water.

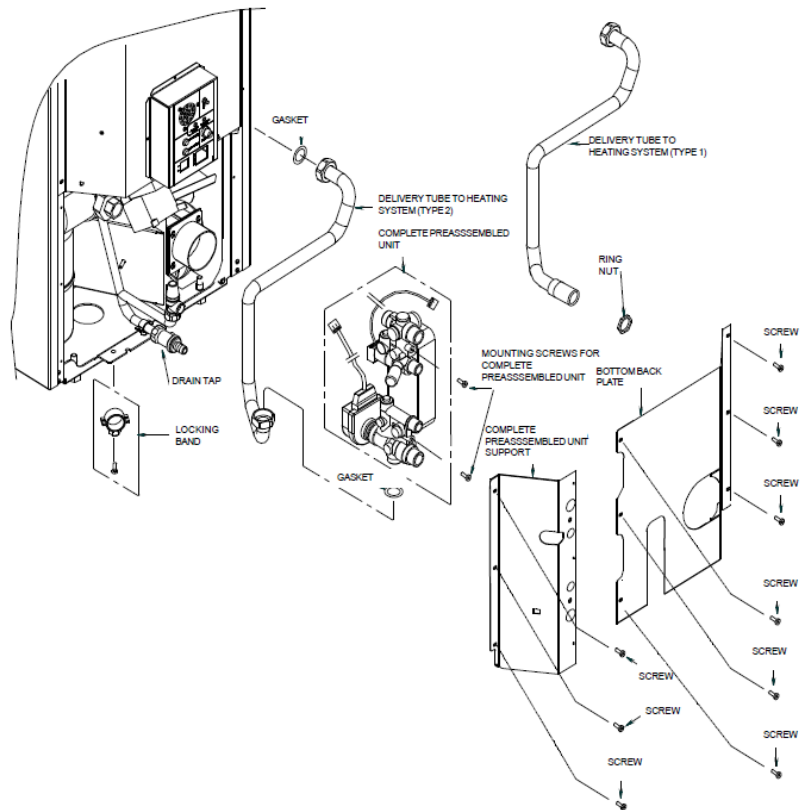

CAUTION: CHECK CAREFULLY THAT THE "HEATING SYSTEM WATER INLET TAP" IS CLOSED BEFORE MAKING THE HYDRAULIC CONNECTIONS BETWEEN THE BOILER AND SYSTEM.

4.11.2 ELECTRICAL INSTALLATION FOR " KIT FOR THE PRODUCTION OF INSTANT DOMESTIC HOT WATER "

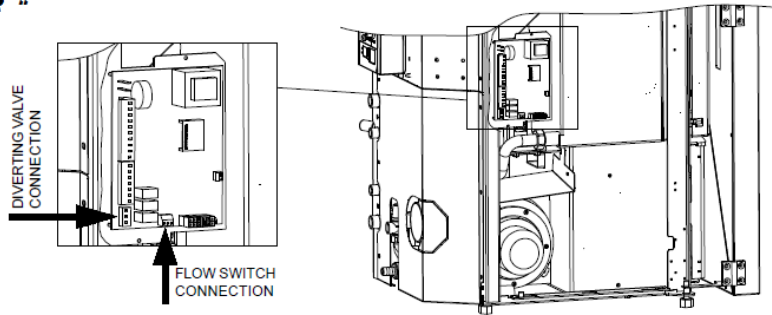

CAUTION: CONNECT, AS INDICATED, THE CONNECTORS SUPPLIED WITH THE KIT FOR THE PRODUCTION OF INSTANT DOMESTIC HOT WATER . THIS OPERATION MUST BE CARRIED OUT WITH THE ' " MAIN SWITCH 0-1 " INSTALLED AT THE BACK IN POSITION " 0 " .

5 USE OF THE HEATER / BOILER



The appliance, when operating, is hot to the touch and the glass in particular is extremely hot: take care not to touch hot parts.

5.1 DESCRIPTION OF THE CONTROL PANEL

The control panel is managed by a microprocessor. The temperature detection system is controlled by a thermocouple. The large display improves the appliance management by making read-outs and functions promptly available. The main feature of the panel is the all-automatic management of the boiler. The controls and displays are described below.

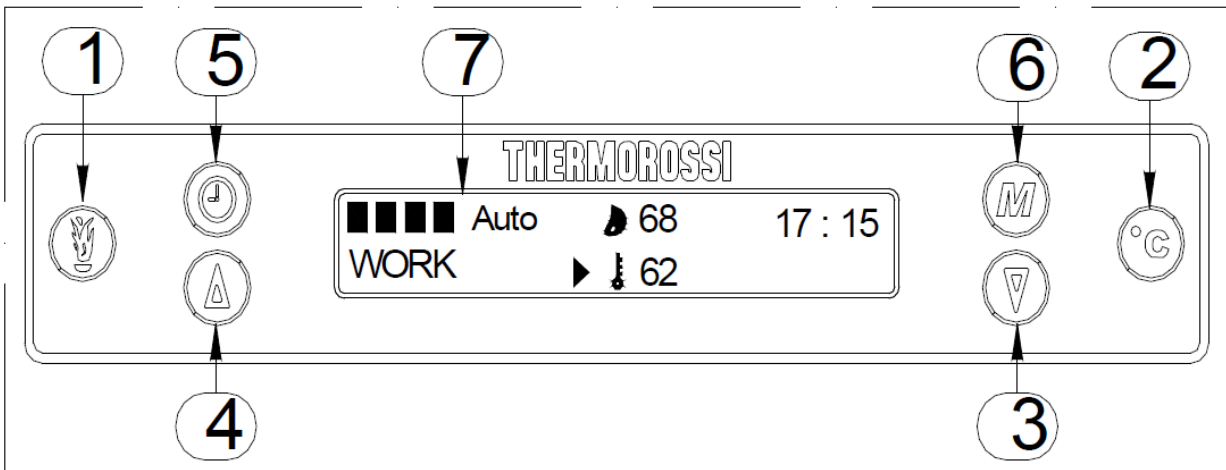

(1) Insert on/off and flame adjustment button . When you press this button the appliance (7) switches to START / OFF. Press repeatedly to activate up to 5 bars and the AUTO indicator is activated (automatic).
START - start up phase: during this phase (lasts approx. 20 minutes) the appliance is self-adjusted independently from the settings.
OFF - shut down phase. As soon as the OFF symbol appears the smoke suction unit operates for a certain amount of time before placing the heater / boiler in stand-by mode.
 The circulator pump begins operating as soon as the temperature in the boiler reaches 61°C.(symbol ► displayed)
 The other boiler operating statuses appear in the display, that is, WORK..... STOP..... WAIT ON.... SUN OUT (para. 5.10)

(2) Button for setting water temperature in boiler. Press this button to set the temperature for the appliance to reach; The setting range is between 65 °C and 73°C. This value is displayed in the area of the display next to the drop symbol. Press this button repeatedly and the following numbers will appear on the display (7) ► 65 ► 66 ► 73 ► 65. The temperature detected by the thermocouple in the boiler is indicated after the symbol ►.

(3) (4) Auxiliary buttons for setting values (only useable within the Menus).
 Press button (3) to lower the value. Press button (4) to raise the preset value.

(5) Programming Enable / Disable keys. Press this button to activate/deactivate the programming (presence/absence of the symbol on the display (7)).







(6) "MENU" selection button To access the main menu press the indicated button. Press button 6 repeatedly to scroll the adjustment, setting and programming windows (see next paragraphs). To return to the operating status simply continue to press the button (6) repeatedly.

When the button is pressed repeatedly the following words appear in sequence :



- DATE** .. to set the day of the week the hour and minutes.
- CHRONO** .. to set the chronothermostat.
- LEVEL** .. to vary the rotating speed of the smoke suction unit, the fuel consumption does not change.
- THERMOCONTROL** .. the operating temperature for Sensor S1 and Sensor S2 can be activated and set if the plumbing system is fitted with Thermocell.
- ITALIANO** .. to select the language (ITALIAN ... ENGLISH...)

To access the functions of each subwindow wait a few seconds then act as described in the following paragraphs.

(7) Display various information are displayed here.

-  HEATER OFF
-  1 POWER LEVEL (The appliance remains always at this power level)
-  2 POWER LEVELS (The appliance remains always at this power level)
-  3 POWER LEVEL (The appliance remains always at this power level)
-  4 POWER LEVELS (The appliance remains always at this power level)
-  5 POWER LEVELS (The appliance remains always at this power level)
-  **Auto** AUTOMATIC (The appliance modulates the thermal power according to system demands)
(For further details see the following paragraph)

- Time

-  indicates that the circulation pump is activated when the temperature exceeds 61°C.
-  indicates the maximum boiler water temperature adjustable by means of button (2).
-  indicates the boiler water temperature detected by the thermocouple.

5.2 DESCRIPTION OF THE REAR PANEL

- (8) **Power outlet for additional room temperature connection.**(see para. 6.1)
(additional room temperature thermostat not supplied)
- (9) **Power outlet for additional chronothermostat connection.**(see para. 6.2)
(additional chronothermostat not supplied)
- (10) **Loading motor test LED.** The light must come on when the pellet screw feeder starts.
- (11) **Reset thermostat tripped indicator light.** This LED comes on when the reset thermostat is activated.
- (12) **Main switch 0-1**
- (13) **Electrical power outlet for heater / boiler 220-240V 50Hz.**
- (14) **General fuse 3,15 A.**
- (15) **Clamp for connecting Sensor 1** (see hydraulic drawing 4.7)
- (16) **Clamp for connecting Sensor 2** (see hydraulic drawing 4.7)
- (17) **Overtemperature thermostat button cap.**

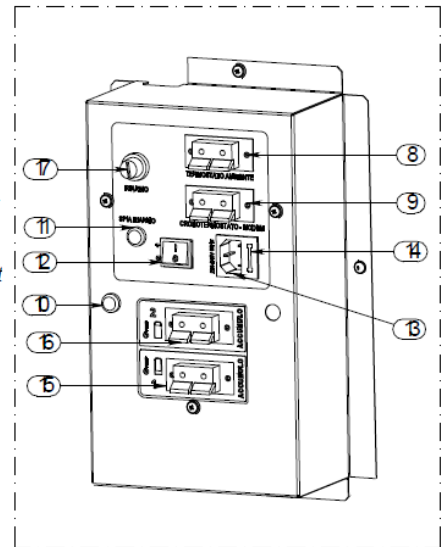

In the event of overtemperature this safety thermostat stops the loading of pellets. When it is activated LED 11 comes on. To restart the heater you have to wait until the water inside it cools down, then verify the cause for the overheating, remove the cause, unscrew the protective cap and press the button.

5.3 DAY AND TIME SETTING

The heater / boiler must be energised and the switch at the back turned to position "1".

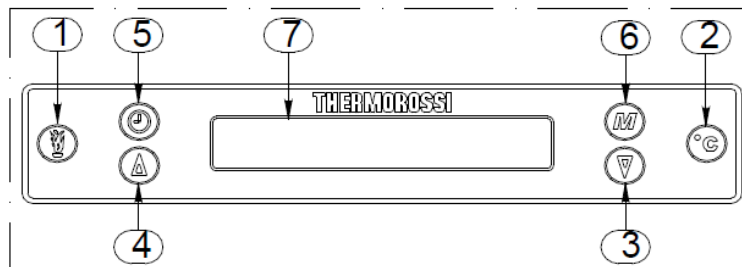

To set the clock and the day of the week carry out the procedures described below. Press button (6) repeatedly until the word **DATE** appears on the Display (7); wait a few seconds for the following indications to appear on the Display (7):

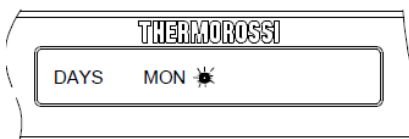

The dot/s begins/begin to blink. Press button (3) and/or (4) to change the day of the week (... TUE 00 ... WED 000 ... THU 0000 ... FRI 00000 ... SAT 000000 ... SUN 0000000 ..). Press the button (2) to confirm. The following indications appear next on the display:

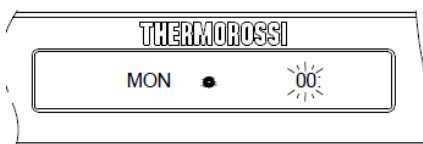

the figures relating to the hours on the clock begin to blink. Press button (3) and/or (4) to change the hours. Press the button (2) to confirm. The following indications appear next on the display:

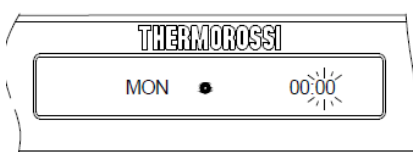

the figures relating to the minutes on the clock begin to blink. Press button (3) and/or (4) to change the minutes. Press the button (2) to confirm. The day and time setting is now completed : at this point the heater / boiler operating status will appear on the display.

5.4 CHRONOTHERMOSTAT: ON/OFF PROGRAMMING

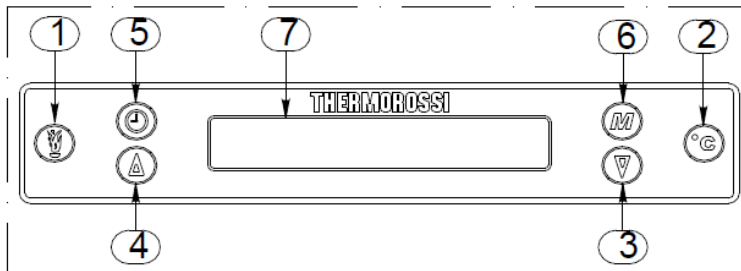

The heater / boiler must be energised and the switch at the back turned to position "1".

It is possible to execute the weekly programming by setting up to 3 on-off cycles for each day from Monday to Sunday. To access the programming mode press the button (6) repeatedly until the word **CRONO** appears: wait a few seconds for the following indications to appear on the Display (7):

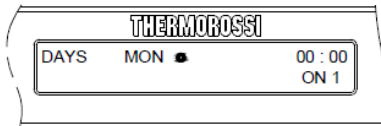

Press button (1) repeatedly to display the desired day in which to enter or change the programming. Press the button (2) to confirm. The following indications appear next on the display:

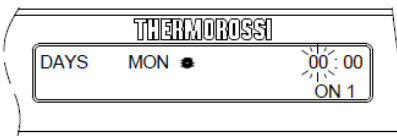

the figures relating to the hours programming for the first startup (ON 1) begin to blink. Press button (3) and/or (4) to change the hours. Press the button (2) to confirm. The following indications appear next on the display:

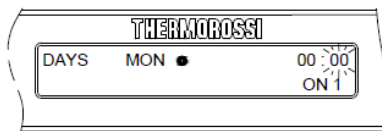

the figures relating to the minutes programming for the first startup begin to blink (ON 1). Press button (3) and/or (4) to change the minutes. Press the button (2) to confirm. The following indications appear next on the display:

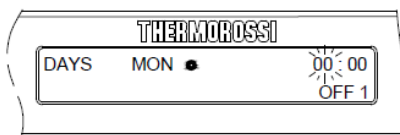

now press button (2) once again and the figures relating to the hours programming for the first shut off (OFF 1) begin to blink. Similarly, as described above, proceed to enter the hours and minutes for the first shut off (OFF 1). Next proceed to program the other on - off cycles for Monday and for the remaining days of the week .

To exit programming simply press button (2): the operating status of the heater/boiler will now appear on the display. Press button (5), while the heater/boiler is running, to enable or disable the programming function.

(when you press button (5) the words ON CHRONO or OFF CHRONO will appear on the display accompanied by the fixed presence or the absence of the symbol).

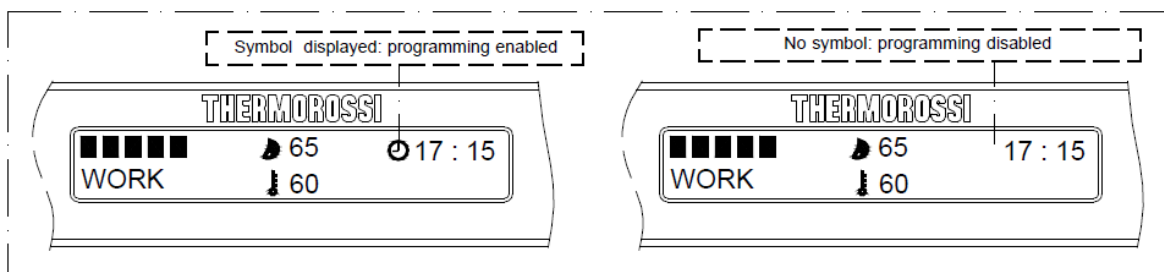

In the event of a programmed cycle on always ensure that the brazier is clean: failure to keep the brazier clean can reduce the life of the spark plug.

5.5 LANGUAGE SELECTION

The heater / boiler must be energised and the switch at the back turned to position "1". Press the button (6) repeatedly until the word ITALIAN appears on the display (7).

To change the display language proceed as follows . Press button (4) repeatedly and the words ENGLISH..... DEUTSCH..... FRANÇAIS..... ESPAÑOL..... ITALIANO..... appear on the display. Select the desired language and press the button (2): at this point the heater / boiler operating status will appear on the display.

The operating alarms will be displayed in the selected language.

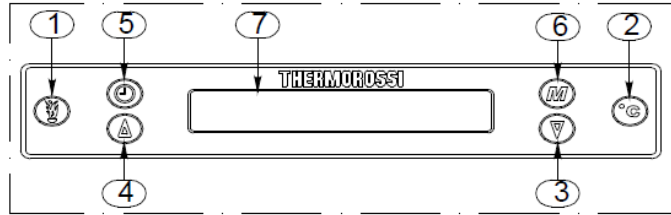

5.6 OPERATING LEVEL SETTING

The heater / boiler must be energised and the switch at the back turned to position "1".

Your appliance is delivered with an excellent program installed that favours combustion yield; the program is called **LEVEL 1**.

If you are using pellets with a higher than normal incidence of residues after combustion in the brazier, alternative levels may be selected:

LEVEL 2 : this program increases the smoke suction unit speed acceleration.

LEVEL 0 : when using lightly-compressed pellets and/or flue outlets with very high vacuum, over 2 mm water column.

The pellet consumption value is not affected by the operating level settings.

Select the required level by acting as follows:

Press button (6) repeatedly until the word **LEVEL** appears on the display then after a few seconds the word **LEVEL** followed by the value set on the heater / boiler (**LEVEL 01** or **LEVEL 02** or **LEVEL 00**). In order to change the operating level as key (4) is kept pressed, press the key (3). Hold down button (4) once again and press button (3) to change the level.

To return to the boiler operating status simply press button (6) repeatedly until the operating status appears



The level selection can be made with the heater / boiler **OFF** or **ON**. If the change is made while the insert is running the difference in the flame will be apparent. It is mandatory to pay particular care when selecting the most appropriate operating cycle for your installation. After the selection of the operating cycle a thorough cleaning of the brazier is mandatory.

5.7 WATER PRESSURE IN THE GENERATOR

The water pressure in the generator can be viewed on the display, see paragraph 5.10.

5.8 ACTION TEMPERATURE SETTING "SENSOR 1 " THERMOCELL AND "SENSOR 2 " THERMOCELL" AS INDICATED IN THE HYDRAULIC DRAWING para. 4.7.

The heater / boiler must be energised and the switch at the back turned to position "1".

Press the button (6) repeatedly until the word **THERMOCONTROL** appears on the display (7). After a few seconds the inscription **THERMOCONTROL ON** or **THERMOCONTROL OFF** will appear. Press button (4) and/or (3) to activate or deactivate the **THERMOCONTROL** function (**ON** or **OFF**). Press the button (2) to confirm. If the selection is **THERMOCONTROL OFF**, when you confirm by pressing button (2), the operating status of the heater / boiler will appear next on the display.

If the selection is **THERMOCONTROL ON**, when you confirm by pressing button (2), the following indications will appear on the display:

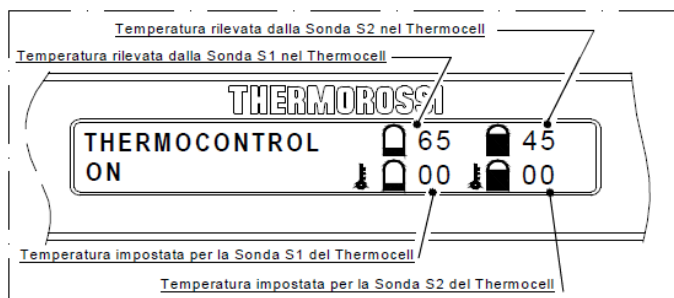

The figures relating to the Sensor S1 setting begin to blink. Press button (4) and/or (3) to set the action temperature for Sensor S1.

Press button (2) to confirm. Next the figures relating to the setting of Sensor S2 begin to blink. Press button (4) and/or (3) to set the action temperature for Sensor S2. Press button (2) to confirm. At this point the heater / boiler operating status will appear on the display.

LEGENDA

Temperatura rilevata dalla sonda S1 / S2 nel Thermocell
Temperatura impostata per la sonda S1 / S2 del Thermocell

KEY

Temperature detected by sensors S1 / S2 in the Thermocell
Temperature set for sensors S1 / S2 of the Thermocell

CAUTION: it is advisable to set the action temperature for sensors S1 and S2 as indicated in the hydraulic drawing in para. 4.8.

CAUTION: when THERMOCONTROL ON is set on the heater / boiler, it starts up and shuts off autonomously only depending on the S1 and S2 temperatures that are detected and set in the Thermocell. In this case manual or programmed start ups and shut offs or those triggered by an external room temperature thermostat or by an external chronothermostat are completely ignored .

When THERMOCONTROL ON is selected the word PUF and the detected S1 and S2 temperatures are displayed during the operating phases; see the image.

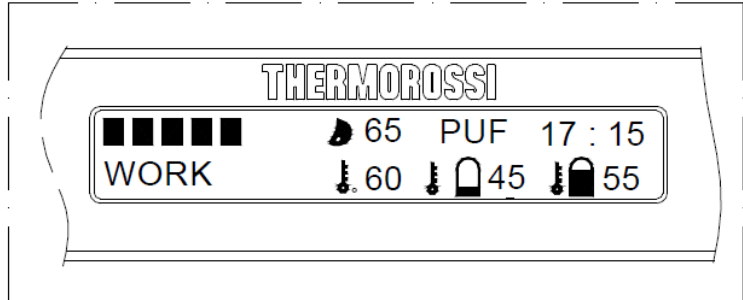

5.9 INFORMATION ABOUT HOW THE GENERATOR WORKS

5.9.1 DESCRIPTION OF THE OPERATING FUNCTIONS

The main operating phases are the following:

START	----> identifies the start up phase
WORK	----> identifies the operating phase
OFF	----> identifies the shut down phase
STOP	----> identifies the phase in which the boiler / heater exceeds a temperature of 80°C.
WAIT ON	----> identifies the phase preceding start up when the temperature in the boiler is over 63°C.
SUN OUT	----> identifies the excess heat dissipation phase (function only present when Thermocontrol is set on ON; see para. 5.8).

START----> : has a duration of approx. 20 minutes, during this time the generator is programmed to light the flame. For this reason the generator will not accept power variations in the firebox. The possibility of the generator not executing the lighting correctly can be attributed to the following factors: cleanliness of the generator, smoke exhaust particularly cold, sudden surges and drops in the electric power supply, fuel is moist or does not comply with the specifications (see para. 3.2) .

WORK : the duration depends on the ability of the system to receive heat. The generator's operating status is displayed.

OFF : has a duration of approx. 20 minutes, in this phase the generator is switched off until a new "on" phase is initiated. The aim is to make the pellet embers in the burner die out completely. The temperature of the generator will drop until the system is completely cooled down.

STOP : If the temperature of the generator exceeds the 80°C threshold, the momentary shut off, identified as STOP, is activated. In this situation the generator is reactivated by means of a new START phase, as soon as the temperature drops below 58°C. The STOP phase indicates that in the following time the generator will execute a new START phase: the generator shut down is only temporary.

WAIT ON : In the event of a hot restart (where the boiler temperature is above 63°C) the heater / boiler does not start up immediately but the message WAIT ON appears on the display. When the boiler temperature reaches 58°C the lighting phase will begin, the message WAIT ON disappears and the word START appears.

LEGENDA	KEY
Temperatura acqua generatore (°C)	generator water temperature (°C)
Avvio	Start
Lavoro	Running
Off	Off
Tempo (minuti)	Time (minutes)

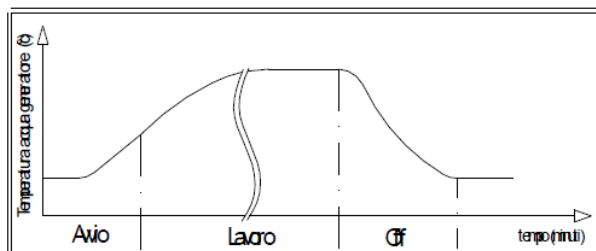

SUNOUT: this function only activates automatically if the THERMOCONTROL setting is set on ON and if Thermosole solar panels are connected to the Thermocell. If Sensor S2 in the Thermocell detects a temperature exceeding 85°C in the OFF phase the word SUNOUT appears on the display accompanied by the pump active indicator and by the activation of ' smoke suction unit at the maximum power. When sensor S2 temperature drops to 65°C the word SUNOUT disappears and is replaced by the word OFF and at the same time the circulator pump and the smoke suction unit switch off. This guarantees the dissipation of the excess heat input from the solar panels: situation occurring during the summer period.

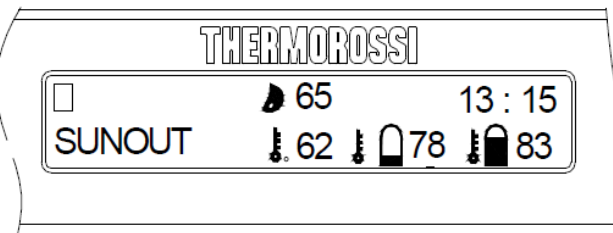

5.9.2 SETTING RANGE

The heat transfer takes place according to the principle of anticondensation, that is by activating the pump at a threshold that, in this specific case, is 61°C. Activating the pump at a lower threshold would lead to the formation of acid condensation which is harmful for the life of the generator. The lowest temperature value in the setting range is 61° C.

The maximum temperature possible for selection is 73°C; once this value is exceeded the machine runs at the minimum steady state level.

The STOP phase trips if the 80 °C limit is exceeded.

The maximum temperature can be selected by means of the °C button (2) (see para. 5.1) on the control panel. This temperature can be set between 65 °C and 73°C. Every time you press the button you will notice the symbol appear on the screen followed by the value in figures.

5.9.3 AUTOMATIC OPERATING CYCLE

In the automatic operating cycle the generator expresses its maximum flexibility of operation while optimising fuel consumption. To activate the AUTO cycle, select the power bars until the word AUTO appears. During the **AUTO** cycle the heater / boiler self-regulates the combustion according to the water temperature in the boiler set with button (2) . If for example the temperature is set at 70°C the five speed levels will be automatically distributed between 61°C and 70°C so that with a temperature set at 70°C the heater / boiler is at its minimum power level. The minimum level can be adjusted by means of button (2). If the value () is increased or reduced by means of button (2) all the power levels will be redistributed along the full temperature range. We therefore recommend finding the best () in order to optimise the full potential of the produced heat.

If for example the value is set at a high temperature, let's say 73°C, the appliance will attempt to reach that level as quickly as possible by modulating the power as it approaches the set temperature. It is not necessary to set high t max temperatures when the ambient conditions do not require them. Time and experience in using the appliance will give you the possibility of determining which are the most appropriate SET POINTS for your needs. If the combustion power is not absorbed by the system above a temperature of 80° C the appliance will temporarily shut down and the word STOP will appear in the display. Reactivation will occur automatically when the temperature drops to 58°C.

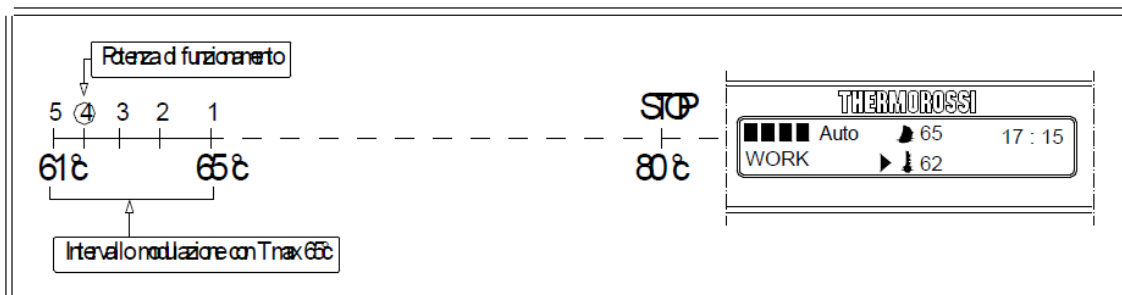
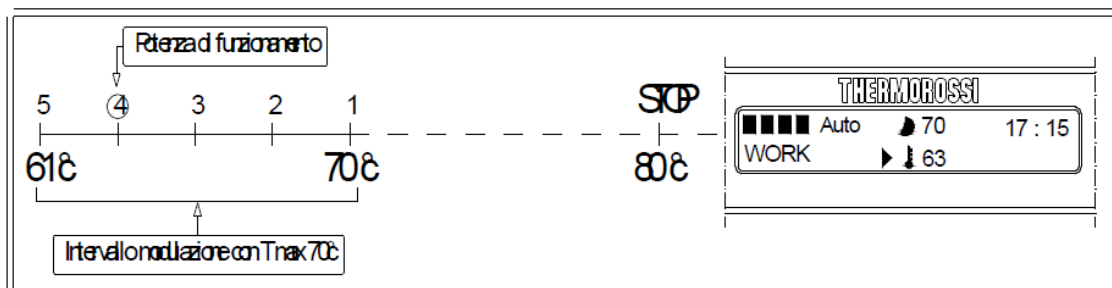

LEGENDA

Potenza di funzionamento
Intervallo modulazione con Tmax 70°C/ 65°C

KEY

Operating power
Intervallo modulazione con Tmax 70°C/ 65°C

5.9.4 MANUAL OPERATING CYCLE

The manual cycle is indicated on the display by the power bars. The power expressed in this cycle remains always constant independently from the power absorbed by the system. As always, the system's circulating pump is activated at the anticondensation temperature, that is above 61° C.

In this case as well, a temperature (●) can be set, above which the heater / boiler will operate at the minimum steady state power level. If an excessive power level is set for the absorption of the system above the temperature of 80° C the heater / boiler will temporarily shut off and the word STOP will appear on the display (6). Reactivation will occur automatically when the temperature drops to 68°C.

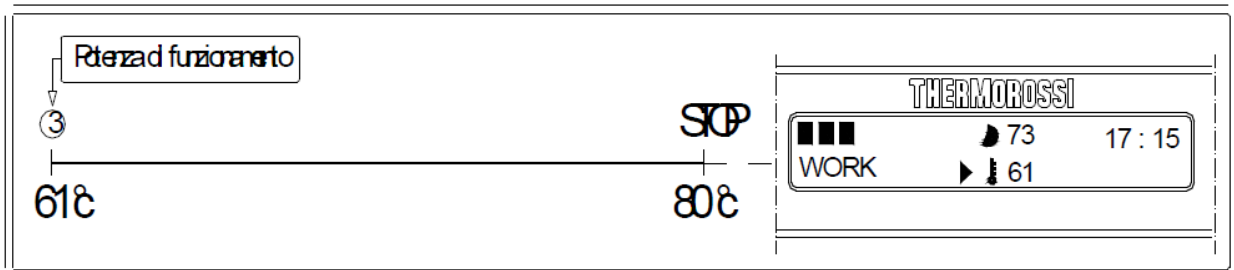

5.11 SWITCHING ON THE HEATER H2O / BOILER COMPACT



Before using the heater / boiler check that all the movable parts are in place; also remove any labels and stickers from the glass to avoid having permanent traces remain on the surfaces. Verify that the electric and hydraulic connections have been made perfectly. Check also (during all the operating phases) that the firebox door and the ash pans are always firmly closed.

Then carry out the following operations:

- Check that the hydraulic system has been correctly executed and has an adequate closed expansion tank to guarantee maximum safety. The expansion must be calculated as specified in UNI 10412/2. Any damage to the plant and/or appliance will not be covered by warranty.

The presence of the expansion tank in the heater / boiler guarantees protection against thermal expansion only and exclusively of the heater / boiler.

- Power up the appliance and turn the switch installed at the back of the heater / boiler to position "1" (= ON).
- Fill the system using the inlet tap.
- Do not overdo the pressure in the appliance during the make-up phase : max pressure 1 bar. The reading of the pressure is executed as explained in para. 10.
- The water fill phase must be simultaneous with the air purge. The purge operation is carried out using a screwdriver or a punch on the purge valve (to accelerate the system filling times).
- Connect the smoke exhaust to the appliance : we recommend against using aluminium tubes and we recommend always using sealing gaskets. Further information is given in paragraph 8 of this use and maintenance booklet.
- Load the pellets into the hopper.
- Press the button (1) to begin the start up phase and the word **START** will appear on the display. Press the button (1) repeatedly to set the appliance in **AUTO** or manual operating mode. The mode will be activated at the end of the start up phase. Press button (2) to adjust the water temperature in the boiler that you wish to reach. During the 20 minutes of the start up phase any set thermal power level is ignored to deal with correct fill up and suction values preset by the Manufacturer. The electrical heater will start to heat and after a few minutes the first lot of pellets will start dropping into the brazier. This occurs because the screw feeder has to fill up because it is completely empty. The first time the heater / boiler is started up the start up phase will have to be carried out twice for this very reason. Before beginning the second start up phase empty and vacuum the brazier.
- Once again check the pressure inside the appliance and if necessary purge any existing air bubbles from the valve provided for this purpose.



CAUTION: The start up phase (word **START** appearing on the display) takes approx. 20 minutes during which the heater / boiler ignores any commands transmitted to it. After this time has elapsed the word **RUNNING** appears on the display. When the machine is in the running phase the combustion can be adjusted manually or in **AUTO** mode.



CAUTION: The circulator pump begins operating as soon as the temperature in the boiler reaches 61°C.
CAUTION: If the appliance does not start up correctly check that the brazier and electric heater are clean. It is very important to ensure that the tube lodging of the electric heater is clean; there must be no deposits or dust. This operation must be carried out with a good vacuum cleaner.

5.12 ADJUSTING THE COMBUSTION OF THE HEATER H2O / BOILER COMPACT

The thermal value is adjusted through 2 buttons (1) and (2) described in para. 5.1.

5.12.1 COMBUSTION ADJUSTMENT IN MANUAL MODE (see para. 5.9.3).

5.12.2 COMBUSTION ADJUSTMENT IN AUTOMATIC MODE (see para. 5.9.4).



CAUTION: The manufacturer denies all responsibility for the life of the electrical heater if subjected to excessive start ups. It is advisable, therefore, to set the correct power level to avoid this danger.

5.13 SHUTTING OFF THE HEATER H2O / BOILER COMPACT

To shut off the heater / boiler simply zero the power bars on the display.

DO NOT shut off the heater by disconnecting the generator from the electric power outlet. This operation could generate smoke that may not be evacuated due to the construction characteristics of your system's smoke discharge tube and chimney.

The shut down time for the smoke exhaust is roughly 25 minutes.

6 ADDITIONAL ROOM TEMPERATURE THERMOSTAT / ADDITIONAL CHRONOTHERMOSTAT (not supplied)

The control panel ensures that your heater / boiler is provided with all the required programming and temperature adjustment functions:

Two pairs of cable clamps are installed at the back of the heater / boiler near the power inlet. They refer to two operating modes:

→ With the room temperature thermostat.

→ With the chronothermostat or modem.

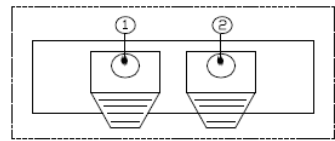

Contacts 1-2 are defined as "CLEAN" contacts and they must never be fed with 220 V. If the board is energised with 220V or with voltages exceeding 6 V the control board will be permanently damaged and will not be covered by the GUARANTEE.

When the external room temperature thermostat or the external room temperature chronothermostat trips and switches on the generator, the word **EXT** appears on the display (see figure on the right).

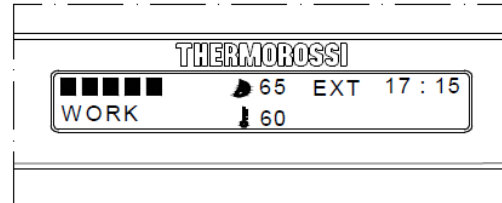

6.1 OPERATING WITH THE ADDITIONAL ROOM TEMPERATURE THERMOSTAT (NOT SUPPLIED)

An additional room temperature thermostat can be installed by connecting it to the back of the heater / boiler, through a cable clamp inserted in the socket labelled "THERMOSTAT" (see drawing in para. 5.2). It has a clean contact, that is a low voltage contact. The operating principle is as follows:

- When the environment reaches the set temperature the thermostat closes the contact and the heater / boiler runs at the minimum combustion power: the situation is described by the appearance of the 1st power bar on the display. Simultaneously, the circulator pump is shut off and a few minutes later the symbol disappears from the display.
- When the room temperature drops the thermostat opens the contact and the heater / boiler returns to its original position in terms of thermal power.

7 CLEANING AND MAINTENANCE

7.1 FOREWORD



Before beginning any maintenance operation ensure that the appliance is in the OFF phase and disconnect it from the electric power outlet.

Your pellet heater / boiler ECOTHERM is a solid fuel generator : it requires frequent controls and general cleaning operations. This will guarantee regular operation and optimal output at all times. If the product is unused for a prolonged period of time it is mandatory to inspect the smoke channel and outlet to ensure that there are no obstructions before use .

7.2 CLEANING AND MAINTENANCE OF HEATER H2O / BOILER COMPACT

• EVERY day and whenever necessary clean the burner .

CAUTION : Clean the burner regularly and thoroughly using a vacuum cleaner, and particularly in the area around the spark plugs: this will guarantee correct functioning of the appliance.

CAUTION : When carrying out this operation avoid knocking or bumping the insulation on the door of the Compact as it could break and this damage is not covered by warranty.

• EVERY day and whenever necessary clean the glass (only for H2O) .

• EVERY day use the riddling tool provides to push and pull the tube scraper 4-5 times (fig.2).

Open the door to the Compact boiler to access the tube scraper.

• EVERY week and whenever necessary vacuum the ash from the compartment C1 (fig. 6).

• EVERY week and whenever necessary empty the ash from the pan C2 (fig. 6).

• EVERY 2 weeks and whenever necessary clean out the smoke exhaust tee at the mouthpiece of the appliance.

• EVERY 2 weeks and whenever necessary vacuum the ash from the compartment C3 (fig. 5).

To access the compartments C1 , C2 , C3 , you must firstly remove the bottom door F (fig. 3.) by firstly pressing the handle downwards, rotating the cover outwards and sliding it upwards: now yo can access compartments C1 , C2 .

To access compartment C3 firstly remove compartment C2 (fig.5. and fig.6) : to access the boiler ash pans you must firstly open the external door.

• EVERY month and whenever necessary vacuum the dust deposited at the bottom of the empty hopper.



Caution: to guarantee correct and optimal combustion it is very important to correctly and hermetically close ash pans C1, C2, C3 after maintenance operations to avoid various situations while it is operating, such as: tripped smoke exhaust pressure switch: "SMOKE EXHAUST CLOGGED ", FAILED START UP.

• EVERY 2 weeks and whenever necessary clean the tube bundle chamber by removing the inspection cap as shown in figure 1. Caution: Take special care when handling the cover and avoid knocking or dropping it ; accidental breakage of the insulation is not covered by warranty.

• **AT THE END OF THE WINTER SEASON OR WHENEVER NECESSARY** we recommend thoroughly cleaning the firebox and drawers of the appliance using brushes and vacuum cleaner.

• AT LEAST ONCE A MONTH and whenever necessary check the smoke exhaust to ensure that it is free from ash deposits, particularly in the initial sections that could have a smaller section.

• AT LEAST TWICE A YEAR clean the flue outlet. If there are any horizontal sections, inspect them and clean out any ash and soot deposits before they block the passage of the flue gases. Also clean behind the combustion chamber shell: to access this area remove the bolts and shift the back wall forward (see fig. 4).



A vacuum device facilitates removal of the ash. Use a damp cloth or a scrunched up piece of newspaper, dampened and rolled in the ash, to wipe the glass until it is perfectly clean. Do not clean the glass while the heater H2O is operating. Remember that the heater must be completely cooled down before the side panel can be cleaned with a soft cloth and water.



Caution: A daily deposit of soot and combustion residues on the glass is quite normal. It is also normal to find partially or totally unburned pellets in the ash pan.

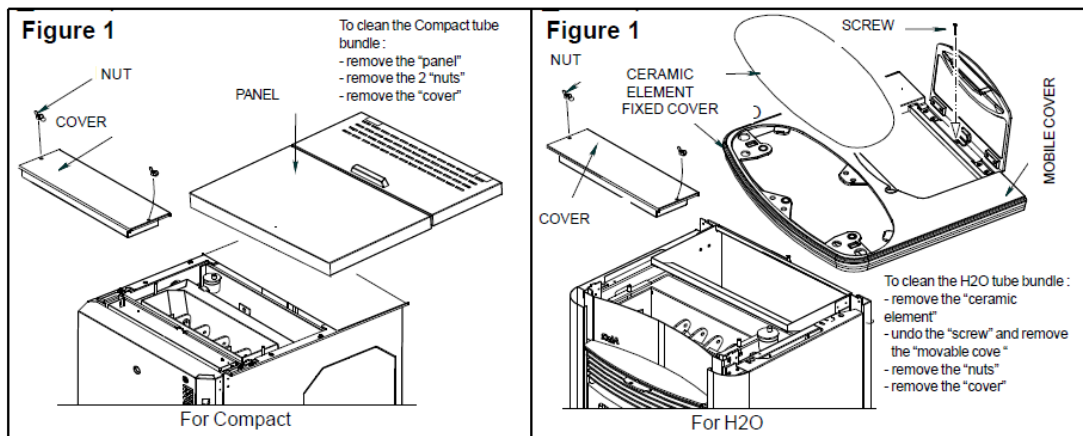

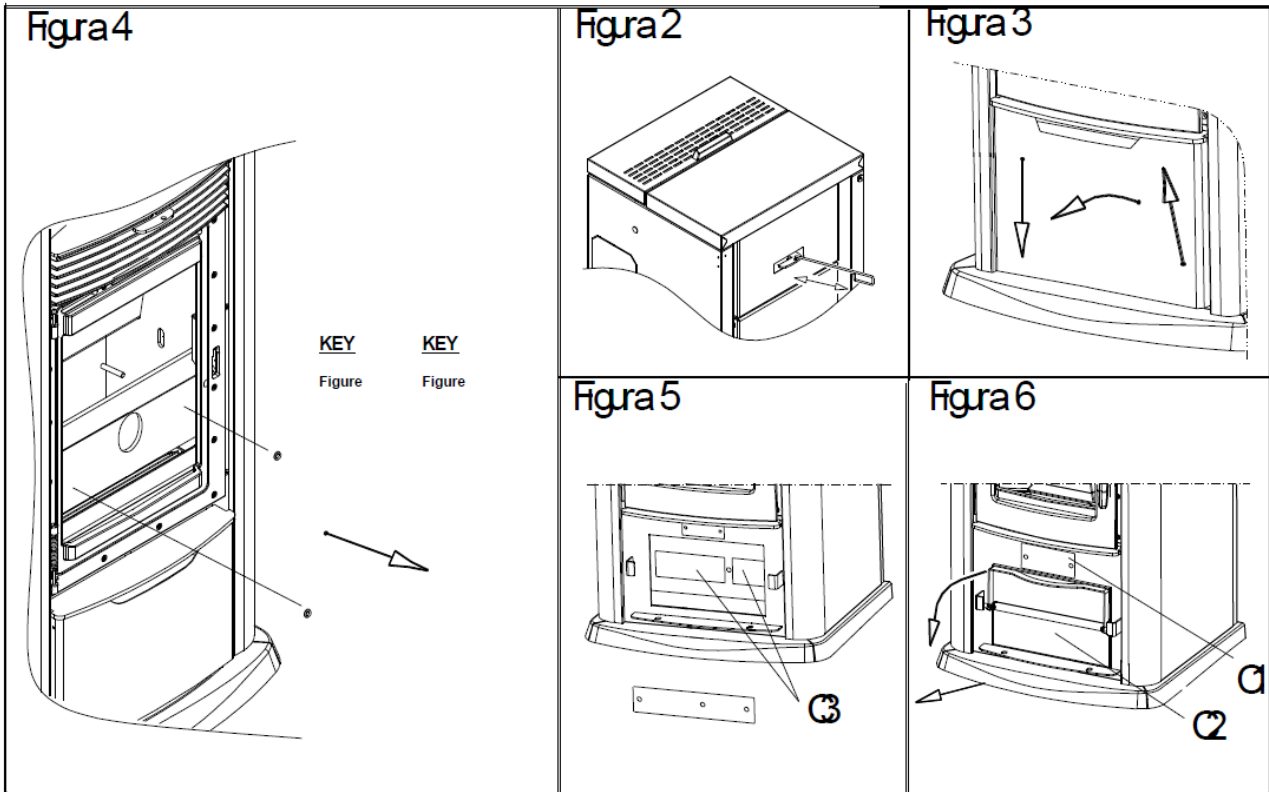

CAUTION : Any cracks on the insulation of the Compact door do not affect the operation of the boiler.

7.3 PATENTED SELF-CLEANING BURNER (no° VI2004A000014)

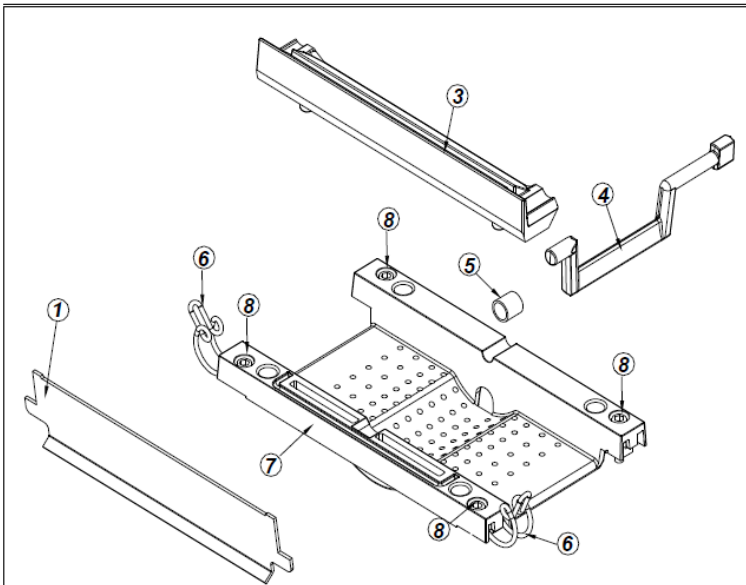

The heater H2O / boiler Compact is fitted with a patented new concept burner that can guarantee high performance and automatic optimal cleaning of the burner thanks to the special technology applied to it. **The combustion generates the separation of the flame into 2 flame fronts: this is to guarantee the optimal exploitation of the combustion chamber walls, always badly utilised in other pellet appliances.** Manual cleaning of the chamber is consequently to an absolute minimum.

To remove the chamber after having removed the back (see para.7.2) act as follows:

- Remove the blade (1) (only present in the H2O).
- Open the latches (6).
- Remove the chute (3).
- Remove the riddler (4) and bearing (5).
- Remove the screws (8) and remove the brazier

To replace the brazier carry out the same actions in reverse order.

In the OFF phase the cleaning time for the brazier, the movement of the riddler (4) is set at roughly 20 minutes.

It is normal to find partially burned embers at the sides of the burner.

CAUTION : Clean the burner regularly and thoroughly using a vacuum cleaner, and particularly in the area around the spark plugs: this will guarantee correct functioning of the appliance (para. 7.2).

8 SMOKE EXHAUST TUBE



Due to the frequent accidents caused by poor functioning of flue outlets installed in private dwellings, we have prepared the following paragraph to assist the installer in his inspection of the parts concerned with eliminating the gases produced by combustion. The smoke exhaust must be installed in compliance with UNI7129/92, UNI 10683 and EN14785 and must respect the following reference values: The instructions provided in the regulations mentioned above must be accurately followed: Otherwise severe damages may occur for the product, the installation, objects and the people who use the generator.

8.1 VENTILATION OF THE ROOMS

• It is essential for the room in which the appliance is installed to be well-ventilated, also to guarantee air for combustion in the heater / boiler. The natural air flow occurs directly through permanent apertures to the outside made in the walls of the room, or by means of single or multiple ventilation ducting.

The ventilating air must come from outside and if possible, away from sources of pollution. Indirect ventilation is also allowed by taking in air from rooms adjacent the one where the insert eater is installed taking into account all the warnings and limitations specified below.

•The apertures in the walls must comply with the following requirements:

- have an unobstructed section of at least 6cm² for each Kw of installed thermal power, with a minimum limit of 100cm²;
- be made in such a way that the vent openings, both on the inside and outside of the wall, cannot be obstructed;
- be protected with grills or similar systems in order not to reduce the section described above;
- be situated at floor-level.

•The air flow can also be obtained from an adjacent room as long as:

- the adjacent room is equipped with direct ventilation in compliance with the points described above;
- in the room to be ventilated the installed appliances are only connected to one flue outlet;
- the adjacent room is not used as a bedroom or a common area of the building;
- the adjacent room is not a room with a fire hazard, such as storage sheds, garages, combustible material store rooms, etc...;
- the adjacent room does not become a vacuum compared to the room to be ventilated due to an opposite draught effect;
- the air flow from the adjacent room to the room to be ventilated is unobstructed through the permanent apertures having an overall net section of no less than that indicated above. These apertures can be obtained by enlarging the space between the door and the floor.



This chapter is not intended to replace UNI 7129/92, UNI 10683 and EN 14785 standards to which it refers. The qualified installer must in any case be fully aware of this standard and its amending versions.

8.2 COMBUSTION AIR INTAKE

The air required for combustion can be taken in from the environment in which the heater H2O / boiler Compact is installed. The room where it is installed must always be adequately ventilated (1300 m³/h).

CAUTION: The presence of extraction fans or similar appliances, if operating in the same room or space in which the heater H2O / boiler Compact is installed, could cause problems for the correct operation of the heater / boiler.

8.3 SMOKE OUTLET

•The smoke exhaust shown in the following figures is the best solution to ensure the discharge of smoke even when the fan is not operational, such as for example if there is an electrical power failure. A minimum drop of 1.5 metres is required between the T terminal on the outside of the building and the outlet at the back of the appliance, to ensure that residual combustion smoke is discharged in the case described above (Otherwise the residues would stagnate inside the firebox and be discharged out to the free atmosphere).

The figures below illustrate the best solution for discharging the smoke out through the roof or into the flue outlet. If you opt to discharge the smoke out through the roof it is important to operate as shown in the figure below on the left. Insert a union tee with inspection cap, connecting brackets suitable for the height of the flue outlet, flashing that crosses the roof and chimney cap to protect against bad weather conditions. If you decide to use a classic masonry outlet see the diagram below on the right. A union tee with inspection cap and suitable supporting brackets are required. If the flue outlet is too big we recommend inserting a stainless steel or porcelain-coated steel tube with a diameter not exceeding 150mm. Seal area where the inlet and outlet part of the smoke exhaust meets the wall. **It is strictly forbidden to apply mesh to the end of the outlet tube, as it could cause the heater / boiler to malfunction.** If the smoke tube is installed in a fixed position it is advisable to provide inspection openings for clean-out purposes especially in the horizontal sections. See the diagram. These openings are essential to allow for the removal of ash and unburned products which tend to accumulate along the discharge path. **The appliance operates with the pressure in the combustion chamber lower than atmospheric pressure, whereas the discharge of smoke to the chimney is slightly pressured, consequently the discharge system must be hermetically sealed.** The smoke discharge tube must be made from suitable materials such as for example: porcelain-coated steel tubes, and the various fittings sealed with red silicone (resistant to 350°C). The outer casing of the tube must be made with insulating material (mineral wool, ceramic fibre) or use pre-insulated tubing. The flue outlet must be able to withstand the action of a fire (in case of fire call the fire brigade immediately).



All the sections of the smoke discharge tubes and the flue outlet must be easy to inspect and remove for internal cleaning. CAUTION: if the flue outlet is not sufficiently insulated and /or if it is too long it could generate condensation. It is advisable to provide a condensation drain near the smoke outlet of the appliance. The appliance must always and only be installed in a single flue outlet system dedicated exclusively to the appliance. If the appliance is connected to a flue system that is non-compliant with the standards the appliance could show signs of early damage due to an anomalous continual overheating of the heater itself : in this case the damaged parts will not be replaced under warranty.

IF THE CHIMNEY CATCHES FIRE DO NOT HESITATE TO CALL THE FIRE BRIGADE IMMEDIATELY.

LEGENDA	KEY
Ispezione	Inspection
Pendenza 3-5%	Slope 3-5%
2-3 m MAX	2-3 m MAX
Altezza superiore a 4 m.	Height more than 4 m.
Interno	Internal
Esterno	External
Protezione dalla pioggia	Rain protection
Lastra di copertura	Cover slab
Lamiera di acciaio a tenuta stagna	Watertight steel sheet

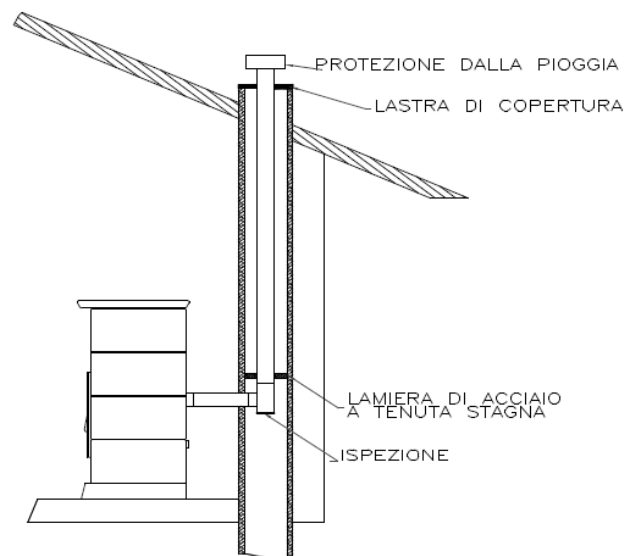
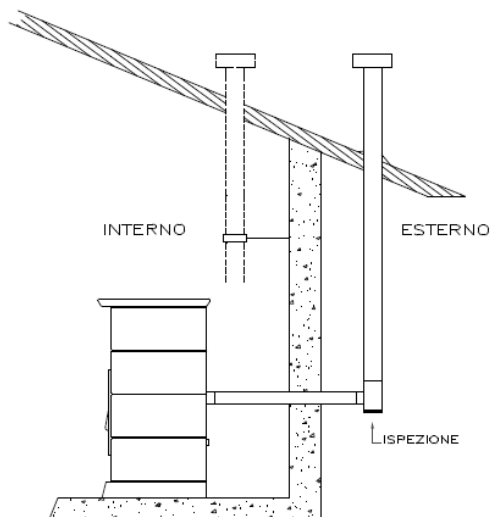
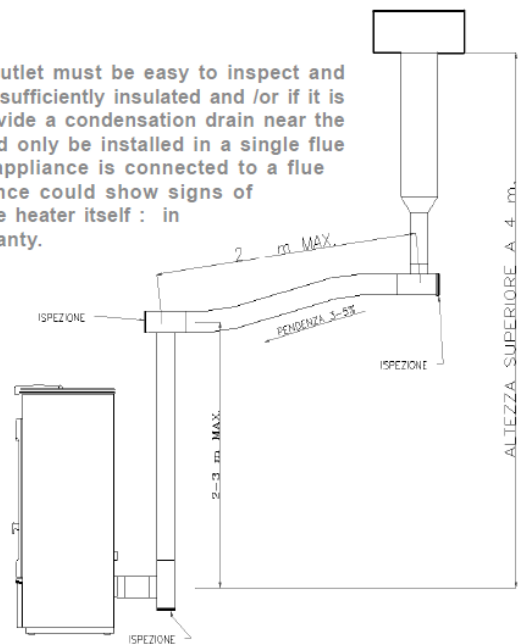

9 ALARMS

The heater / boiler is programmed to communicate 4 fundamental alarms.

The alarms are listed below:

- Pellets finished clean the burner** : is communicated when the temperature during the **RUNNING** mode drops below 42 °C. This indicates that the appliance is switching off due to lack of pellets.
- Start up failed clean the burner** : is communicated if after the start up phase the temperature does not rise above 42°C.
- P GAS** : this occurs when the smoke outlet is partially blocked.
- P H2O** : the pressure in the boiler has dropped below 0.3 bar.

To reset the alarm the fire must be out, disconnect the electric power supply, wait 2 seconds and power up the generator once again.

10 ELECTRICAL WIRING

LEGENDA	KEY
Fusibile 3,15 A / 1A	Fuse 3,15 A / 1A
Aspiratore fumi	Smoke suction unit
Motore pulizia bruciatore	Burner cleaning motor
Termostato sicur riarmo 100°C	Resettable safety thermostat 100°C
Motore caricamento pellets	Pellet loading motor
Resistenza	Heater
Circolatore aggiuntivo	Additional recirculating pump
Circolatore	Circulating pump
Valvola deviatrice (optional)	Diverting valve (optional)
Morsetto 1/2: puffer accumulo	Terminal 1/2: puffer
Flussostato (optional)	Flow switch (optional)
Termostato ambiente (2-8)	Room them. thermostat (2-8)
Cronoterm. modem (3-8)	Chronotherm. modem (3-8)
Pressostato lato fumi (1-4)	Smoke side pressure switch (1-4)
Termostato 42°C (3-8)	Thermostat 42°C (3-8)
Termocoppia	Thermocouple
Pressostato lato acqua	Water side pressure switch

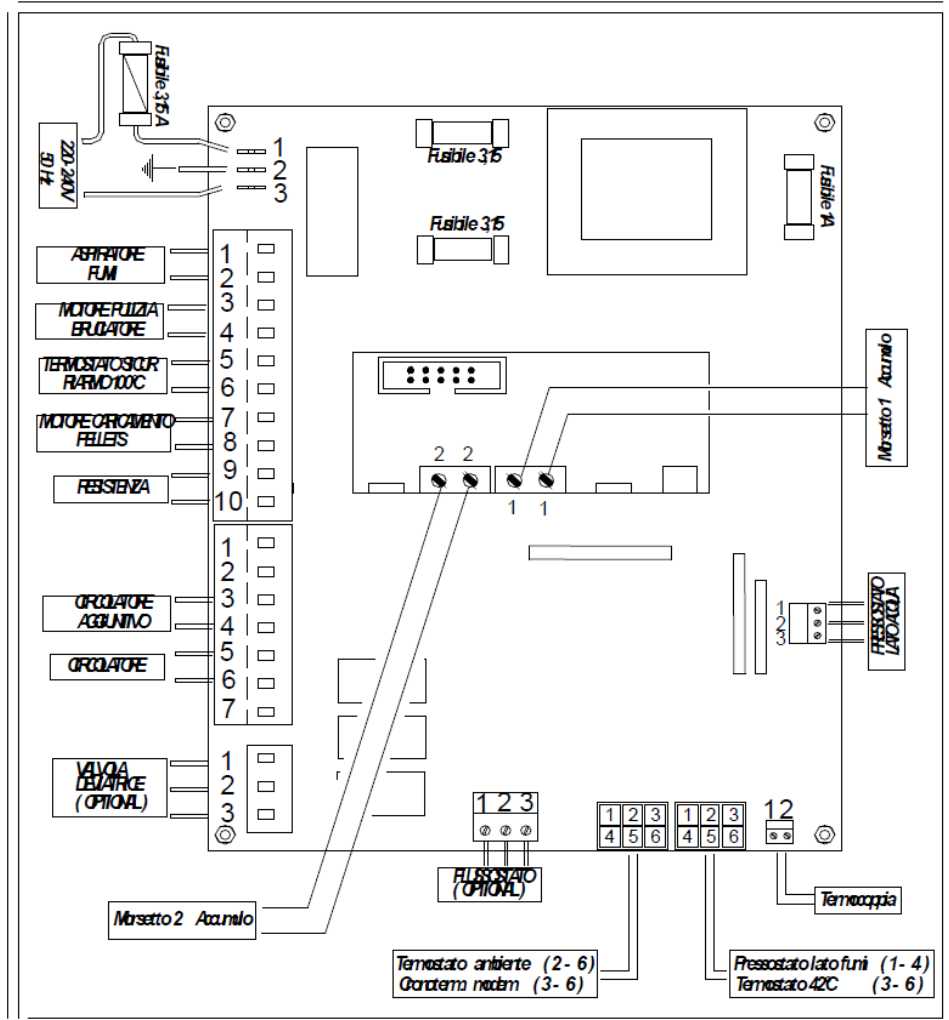

11 INFORMATION FOR THE SKILLED TECHNICIAN

11.1 Main components and their operation

SMOKE PRESSURE SWITCH

This is a safety switch that stops the screw feeder motor whenever necessary. The main cause for the pressure switch tripping is a blocked flue outlet or smoke exhaust pipe. Note that it is strictly forbidden to apply any kind of mesh screen to the end of the pipe. When the holes of the mesh clog up they create a plug that trips the pressure switch which stops the pellet feeder.

SCREW FEEDER MOTOR

This motor is powered at regular on/off intervals controlled by a microprocessor. The operation of this motor is affected when:

- The motor's thermal cutout trips.
- Pellets finished.
- Safety thermostat with manual reset trips.
- The pressure switch trips due to blocked smoke exhaust.
- Intentional shut down of the heater / boiler.

SMOKE SUCTION UNIT

This is activated when the start up signal is given. In the first two minutes it «washes» the smoke discharge tube, that is, it functions at maximum working rate. Once this time has elapsed it self-adjusts to the optimal speed. The exhaust continues to operate for approximately one hour from the time the heater / boiler is switched off to allow for the evacuation of all the smoke and for safety purposes. It stops about half an hour after the thermostat at 42°C opens.

THERMOSTAT AT 42°C

Its function is critical for the following reasons: When the contact closes the heater / boiler powers up and the working cycle starts. Similarly, when the contact opens the smoke exhaust stops.

EXPANSION TANK 2.5 l

This is a safety device intended to compensate for the increased volume of the water in the boiler caused by the increase in the water temperature (Note: this tank is a protection for the boiler only).

SAFETY THERMOSTAT WITH MANUAL RESET

When the temperature exceeds 98°C the pellet feed screw shuts down. A red light at the back of the appliance remains lit. Once the causes for the overtemperature have been identified and remedied the appliance can be reactivated by unscrewing the plastic cover of the thermostat located at the back of the appliance and pressing the button (the heater / boiler temperature must be below 73 °C).

GLOW PLUG

It is activated in the START phase. Heats the air to 800°C, which assist the first combustion of the pellet s present in the brazier.

BOILER PRESSURE GAUGE 0-4 bar

Detects the water pressure in the system. It is installed at the back of the heater/boiler.

AUTOMATIC PURGE VALVE

The function of this valve is to eliminate air residues inside the heater/boiler without the need for manual intervention. Consequently problems such as the following are eliminated:

- corrosive processes caused by the oxygen.
- noise generated by the passage of air in the tubes.
- air pockets in the heating bodies.
- cavitation in the circulator pumps .

SAFETY VALVE CALIBRATED AT 3 BAR

When the calibrated pressure is reached, the valve opens and, by discharging to the atmosphere (the manufacturer recommends connecting this valve to a single outlet to avoid damaging the material surrounding the heater / boiler if it is activated) it prevents the pressure in the system from reaching dangerous limits for the generator and for the components of the system . If it trips verify the reasons and solve the causes for the overpressure.

SYSTEM CIRCULATOR PUMP

This device conveys hot water produced by the appliance to the usage point. The pump signal appears to indicate that it is operating. ►

11.2 USEFUL ADVICE FOR INSTALLATION AND OPERATION

- 1 The appliance must never be deliberately disconnected from the electric power supply. Whenever the appliance is deliberately disconnected from the electric power supply smoke could be emitted into the room and be a hazard. Similarly never switch off the appliance by suddenly cutting off the electric power supply.
- 2 Do not install the appliance with horizontal wall outlets only: evacuation of the combustion products must be guaranteed in a natural manner.
- 3 Do not install the appliance with horizontal sections only: the wall could be exposed to high wind conditions and the appliance could shut down due to back draft.
- 4 Operate the appliance at maximum for 10 hours for a complete drying and baking of the silicates contained in the enamel which covers the body of the heater.
- 5 Do not install a grill or outlet terminal which could restrain the flow of the combustion gases: this could affect the dynamic gas to the point where it would not allow the pellets to burn correctly.
- 6 Read this instruction booklet.
- 7 Keep the appliance clean and check the burner as described in this manual.
- 8 Clean the smoke outlet regularly.
- 9 Use top quality pellets: by saving 20 cents a bag you heat up to 50% less.
- 10 Maximum useable lengths of smoke exhaust tubes:
Painted aluminized steel tubes (1.5 mm minimum thickness), Aisi 316 stainless steel tubes or 0.5 mm enamelled tubes may be used.

Minimum vertical length	4 m
Maximum vertical length	8 m
Length with min slope .5%	0.5 m
Maximum number of elbows at least 0.5 m apart	2

11.3 TROUBLESHOOTING CAUSE-SOLUTION

PROBLEM	CAUSE	SOLUTION
PELLETS DO NOT DROP INTO THE BURNER	PELLET TANK IS EMPTY	FILL UP THE TANK
	FOREIGN BODY SUCH AS NAIL, NYLON, PIECE OF WOOD ON THE FEEDER SCREW ON THE BOTTOM OF THE TANK	REMOVE THE FOREIGN BODY
	SMOKE EXHAUST NOT FREE, OR WITH TERMINAL THAT OBSTRUCTS THE PASSAGE OF SMOKE	CHECK THE SMOKE EXHAUST AS IT COULD BE DIRTY OR CLOGGED
	OUTLET TERMINAL CLOGGED BECAUSE A GRILL OR TERMINAL HAS BEEN INSERTED WHICH PREVENTS THE FREE PASSAGE OF SMOKE	REMOVE THE TERMINAL AND REPLACE IT WITH A MORE SUITABLE ONE.
	SUDDEN GUST OF WIND WHICH HAS MADE THE APPLIANCE GO INTO SAFETY MODE	SWITCH THE POWER SUPPLY TO THE APPLIANCE OFF THEN BACK ON AGAIN
THE APPLIANCE ACCUMULATES PELLETS IN THE BRAZIER WHILE OPERATING	SMOKE EXHAUST NOT FREE, OR WITH TERMINAL THAT OBSTRUCTS THE PASSAGE OF SMOKE	REMOVE THE TERMINAL AND REPLACE IT WITH A MORE SUITABLE ONE. CHECK THE SMOKE EXHAUST AS IT COULD BE DIRTY OR CLOGGED
	BURNER IS DIRTY	CLEAN THE BURNER ON A MORE FREQUENT BASIS
	PELLETS WITH DEPOSIT ABOVE PERMISSIBLE LIMITS	CLEAN THE BURNER MORE OFTEN. SET THE OPERATING PROGRAM P2
THE APPLIANCE SMOKES	OCCURS THE FIRST TIME THE APPLIANCE IS SWITCHED ON AS THE SILICONE PAINT IS BEING BAKED	RUN THE APPLIANCE AT FULL POWER FOR 10 HOURS TO COMPLETE THE BAKING.
	THE SMOKE EXHAUST IS NOT SEALED CORRECTLY	MAKE SURE THAT THE GASKETS HAVE BEEN FITTED TO THE SMOKE EXHAUST PIPES
	IF THE APPLIANCE STARTS TO SMOKE AFTER 25 MINUTES: DIRTY BURNER, VERY DELAYED START.	CLEAN THE BURNER
	IF THE APPLIANCE STARTS TO SMOKE AFTER 25 MINUTES: DELAYED START BECAUSE THE SCREW FEEDER IS EMPTY	FILL UP THE TANK
THE APPLIANCE SHUTS OFF 5 MINUTES AFTER THE END OF THE START UP CYCLE	DELAYED START BECAUSE THE SCREW FEEDER IS EMPTY	FILL UP THE TANK
	DIRTY BURNER, VERY DELAYED START.	CLEAN THE BURNER
THE GLASS IS COVERED IN BLACK SOOT (H2O)	THE APPLIANCE ACCUMULATES PELLETS IN THE BRAZIER	SEE POINT "PROBLEM-CAUSE-SOLUTION" "THE APPLIANCE ACCUMULATES PELLETS IN THE BRAZIER WHILE OPERATING"
	NO CAUSE	CLEAN THE GLASS MORE OFTEN
THE APPLIANCE IS OFF BUT THERE ARE UNBURNT PELLETS IN THE BRAZIER	THE TANK IS EMPTY	EMPTY THE BURNER AND FILL UP THE TANK.

12 PARE PARTS

