



THERMOROSSI

HEATING TECHNOLOGY AND INNOVATION

INSTALLATION, USE AND MAINTENANCE GUIDE

ECOTHERM 3001

ECOTHERM 3001 THERMOCOMFORT

www.thermorossi.com

CONTENTS

DECLARATION OF CONFORMITY

1.	INTRODUCTION
1.1	General guidelines
1.2	Safety guidelines
1.3	Standards and recommendations
1.4	Transportation and storage
2.	TECHNICAL CHARACTERISTICS
3.	GENERAL DESCRIPTION
3.1	Operating technology
3.2	Pellets
3.3	The feedbox
4.	INSTALLATION
4.1	Heater location
4.1.1	Mounting metalcolor casing
4.1.2	Mounting ceraming casing
5.	DESCRIPTION OF "ECOTHERM 3001" CONTROLS
5.1	Description of grey handheld radio control and heater rear panel
5.2	Day and time setting
5.3	On/Off programming
5.4	Voice information volume control
5.5	Operating level setting
5.6	Language selection
5.7	Data analysis
5.8	Transmission-reception alarms
5.9	Automatic / Manual operating mode
5.10	Transmission code setting
5.11	Care and maintenance of the radio control
5 A.	DESCRIPTION OF "ECOTHERM 3001 THERMOCOMFORT" CONTROLS
5A.1	Description of control panel and heater rear panel
5A.2	Day and time setting
5A.3	On/Off programming
5A.4	Operating level setting
6.	USE OF THE "ECOTHERM 3001" HEATER
6.1	Switching on the heater
6.2	Adjusting the heater's combustion
6.3	Filter
6 A.	USE OF THE "ECOTHERM 3001 THERMOCOMFORT" HEATER
6A.1	Switching on the heater
6A.2	Adjusting the heater's combustion and ventilation
6A.3	Infrared control
6A.4	Operation of the white handheld radio control (optional)
6A.5	Filter
7.	ADDITIONAL ROOM TEMPERATURE THERMOSTAT (not supplied) FOR "ECOTHERM 3001" / ADDITIONAL CHRONOTHERMOSTAT (not supplied) FOR "ECOTHERM 3001"
7.1	Operating with the additional room temperature thermostat (not supplied)
7.2	Operating with the additional chronothermostat (not supplied)
7 A.	ADDITIONAL ROOM TEMPERATURE THERMOSTAT (not supplied) FOR "ECOTHERM 3001 THERMOCOMFORT" / ADDITIONAL CHRONOTHERMOSTAT (not supplied) FOR "ECOTHERM 3001 THERMOCOMFORT"
7A.1	Operating with the additional room temperature thermostat (not supplied)
7A.2	Operating with the additional chronothermostat (not supplied)

8.	CLEANING AND MAINTENANCE
8.1	Foreword
8.2	Cleaning and maintaining the heater.....
8.3	Charging the handheld radio control battery
8.4	Replacing the battery in the infrared remote control (applies only to ECOTEHRM 3001 THERMOCOMFORT).....
8.5	Replacing the buffer battery of the control panel (applies to ECOTHERM 3001 THERMOCOMFORT)
9.	SMOKE DISCHARGE TUBE
9.1	Ventilation of the rooms.....
9.2	Smoke outlet.....
10.	VOCAL ALARMS FOR ECOTHERM 3001.....
10A.	ALARMS FOR ECOTHERM 3001 THERMOCOMFORT
11.	ELECTRICAL WIRING DIAGRAM FOR ECOTHERM 3001.....
11A.	ELECTRICAL WIRING DIAGRAM FOR ECOTHERM 3001 THERMOCOMFORT.....
12.	INFORMATION FOR THE SKILLED TECHNICIAN.....
12.1	Main components and their operation.....
12.2	Useful advice for installation and operation.....
12.3	Troubleshooting problem-cause-solution (applies to ECOTHERM 3001).....
12.4	Troubleshooting problem-cause-solution (applies to ECOTHERM 3001 THERMOCOMFORT)
13	SPARE PARTS
13.1	Spare parts for " Ecotherm 3001 " and " Ecotherm 3001 Thermocomfort ".....
13.2	Spare parts for " Ecotherm 3001 " and " Ecotherm 3001 Thermocomfort ".....
13.3	Spare parts for " Ecotherm 3001 " and " Ecotherm 3001 Thermocomfort ".....
13.4	Spare parts for " Ecotherm 3001 " and " Ecotherm 3001 Thermocomfort ".....
13.5	Spare parts for " Ecotherm 3001 ".....
13.6	Spare parts for " Ecotherm 3001 Thermocomfort ".....

THERMOROSSI S.p.A.
Via Grumolo, 4
36011 ARSIERO
tel. 0445.741310
fax 0445.741657



"CE" DECLARATION OF CONFORMITY

In accordance with the following directives:

European Directive	73/23/EEC and its amending directive	93/68/EEC
	89/336/EEC and its amending directives	93/68/EEC 92/31/EEC 93/97/EEC

Thermorossi S.p.A., Via Grumolo 4 - ARSIERO (VI), declares that the heaters of the ECOTHERM series have been designed and manufactured in compliance with the safety requirements of the standards for EC marking.
This declaration refers to the entire range of the specified series.
Ecotherm 3001 complies with EN 14785: 2006.

ARSIERO , 03 May 2010

THERMOROSSI S.p.A.



1 INTRODUCTION

1.1 GENERAL GUIDELINES

This installation, use and maintenance guide is an integral and essential part of the product and must be kept by the user. Before commencing with the installation, use and maintenance of the product, carefully read all the instructions contained in this booklet. At the time of installation of the appliance all local regulations, including those that refer to national and European regulations, must be observed. The Manufacturer recommends carrying out all the maintenance operations described in this manual.

This appliance must only be used as intended by the manufacturer. Any other use is considered incorrect and therefore hazardous; consequently, the user shall be totally liable for the product if used improperly. Installation, maintenance and repairs must be carried out by personnel with professional qualifications and in compliance with current regulatory standards and in accordance with the instructions of the manufacturer of the appliance. Use only original spare parts.

Incorrect installation or poor maintenance could injure or damage people, animals or things; in this case the manufacturer shall be relieved of all responsibility. Before commencing any cleaning or maintenance operation ensure that the appliance has been disconnected from the mains power supply by means of the main system switch or some other disconnecting device installed upstream from the appliance. The product must be installed in locations suitable for fire-fighting and furnished with all the services (power and outlets) which the appliance requires for a correct and safe operation. Any repairs or actions carried out on any systems, components or internal parts of the appliance, or on any of the accessories supplied with it, that are not specifically authorised by Thermorossi s.p.a, will automatically void the warranty and the manufacturer's responsibility, pursuant to D.P.R. 224 of 24/05/1988, art. 6/b . Use only original Thermorossi spare parts. If the appliance is sold or transferred to another user ensure that the guide is handed over with it.

Thermorossi S.p.A. maintains the author's rights on these service instructions.

The information in this booklet may not be reproduced or given to third parties or used for competitive purposes without the appropriate authorization.

1.2 SAFETY GUIDELINES

PERSONAL INJURY

This safety symbol identifies important messages throughout the manual. Read the information marked by this symbol carefully as non-observance of this message can cause serious injury to persons using the heater.



DAMAGE TO PROPERTY

This safety symbol identifies messages or instructions that are fundamental for the heater and system to function well. To avoid serious damage to the heater adhere strictly to these instructions.



INFORMATION

This symbol indicates important instructions for good functioning of the heater. If this information is not correctly observed, the performance of the heater and/or system will not be satisfactory.



1.3 STANDARDS AND RECOMMENDATIONS



NORMATIVE REFERENCES: national and international standards used as reference guides in the following manual for the design, industrialization and production of the products:

- European directive 73/23/EEC
- Standard CEI EN 60204
- European directive EN 14785: 2006
- Standard CEI 61/50
- European directive 89/336/EEC
- European directive 93/68/EEC
- Standard CEI 64-8 (IEC 364)

RECOMMENDATIONS

Before using the appliance, carefully read every section of this instruction manual as knowledge of the information and the regulations contained in it are essential for a correct use of the appliance.

The entire operation concerning the connection of the electric panel must be carried out by expert personnel; no responsibility will be accepted for damages, even to third parties, if the instructions for installation, use and maintenance of the appliance are not followed scrupulously. Modifications made to the appliance by the user or on his behalf, must be considered to be under his complete responsibility. The user is responsible for all the operations required for the installation and maintenance of the appliance before and during its use.

GENERAL WARNINGS

Caution: the appliance must be connected to a system provided with a PE conductor (in compliance with the specifications of 73/23/EEC, 93/98/EEC, concerning low voltage equipment). Before installing the appliance check the efficiency of the earth circuit of the power supply system.

Caution: the power supply line must have a section which is suitable for the power of the equipment. The cable section must in any case be no less than 1.5 mm². The appliance requires a power supply of 220-240 V and 50 Hz. Voltage variations 10% above the nominal value can cause irregular operation or damage to the electrical device. Position the appliance so that the electric power plug is easily accessible. Voltage variations less than 10% of the nominal value can cause lighting and use problems.

Apply a current regulator. Ensure that a suitable differential switch is installed upstream from the equipment.

1.4 TRANSPORTATION AND STORAGE

TRANSPORTATION AND HANDLING

The heater body must always be in a vertical position when handled and exclusively by means of trolleys. Take special care to protect the electric panel, the glass, the ceramics and all the fragile parts from mechanical impact which could damage them and their correct functioning.

STORAGE

The heater must be stored in a humid-free environment and sheltered from the weather; do not place the heater directly on the floor. The Company denies all responsibility for damage caused to wood floors or floors made from any other material.

It is inadvisable to store the heater for long periods of time.

2 TECHNICAL CHARACTERISTICS *

*All the data are based on the appliance fuelled with Austrian standard O M 7135 type-approved pellets.

	<i>Ecotherm 3001 Easy-Metalcolor</i>	<i>Ecotherm 3001 Ceramic element</i>
	<i>Ecotherm 3001 Thermocomfort Easy-Metalcolor</i>	<i>Ecotherm 3001 Thermocomfort Ceramic element</i>
Height (mm)	955	955
Depth (mm)	484	484
Width (mm)	460	460
Weight (Kg)	118	143
Rated power (Kw)	9,2	9,2
Reduced rated power (Kw)	2,5	2,5
Consumption min/max (Kg/h)	0,7 – 2,3	0,7 – 2,3
Smoke outlet tube D. (mm)	80	80
Min. draught at rated power (Pa)	12	12
Hopper capacity (Kg)	approx. 16	approx. 16
Average smoke temp. at rated power (°C)	180	180
Smoke flow at rated power (g/sec)	5,5	5,5
Electricity	220 V 50 HZ	220 V 50 HZ
Max electrical consumption	1,17 A – 270 W	1,17 A – 270 W
Min electrical consumption	0,34 A – 70 W	0,34 A – 70 W

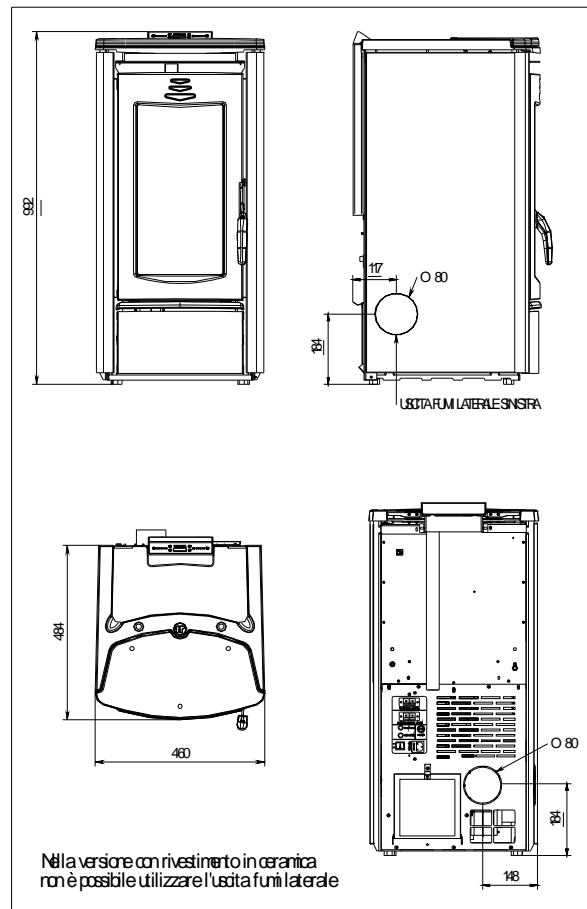
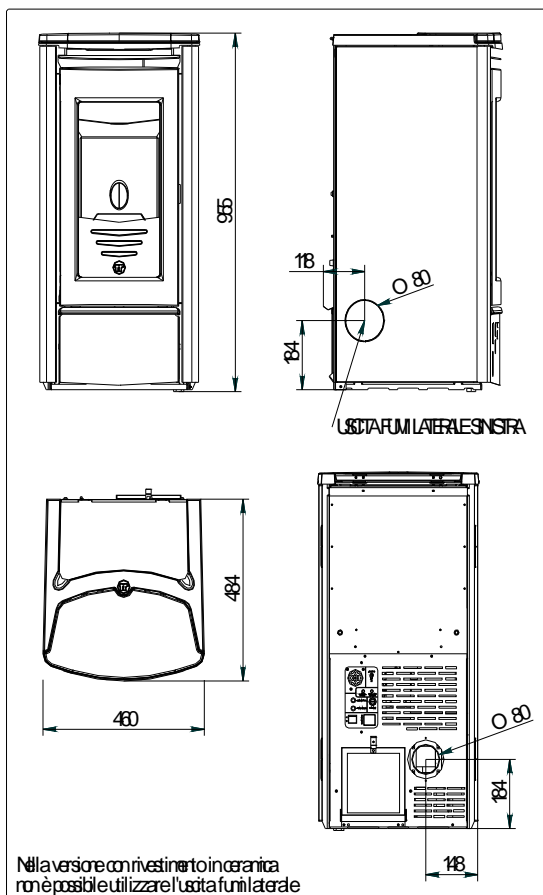

LEGENDA

USCITA FUMI LATERALE SINISTRA

Nella versione con rivestimento in ceramica non è possibile utilizzare l'uscita fumi laterale

KEY

LEFT SIDE SMOKE OUTLET

The side smoke outlet cannot be used for the model with the ceramic casing

3 GENERAL DESCRIPTION

3.1 OPERATING TECHNOLOGY

•Your heater has been built to fully satisfy all your heating and practical requirements. Top-grade components and functions managed with microprocessor technology guarantee high reliability and optimal performance.

3.2 PELLETS

•The appliance is fuelled by pellets, that is, cylinders of compressed sawdust; this will make it possible for you to enjoy to the full the heat of the flame without having to manually stoke the combustion. •The pellets are cylinders of compressed sawdust having a 6 mm diameter and a maximum length of 15 mm. They have a maximum moisture content of 8%; a thermal value of 4000/4500 Kcal/Kg and a density of 620-630 Kg/m³.



The use of fuel which does not comply with the description given above immediately voids the heater warranty. Do not use the appliance as an incinerator, at the risk of voiding the warranty.

3.3 THE FEEDBOX



The feedbox is situated in the top part of the heater. The maximum load capacity of the tank is approximately 16 Kg, but varies according to the specific weight of the pellets. **The manufacturer recommends emptying the hopper and vacuuming the screw feeder zone once a month and during the summer period. Take special care when loading the hopper as the screw feeder at its base is in motion.**

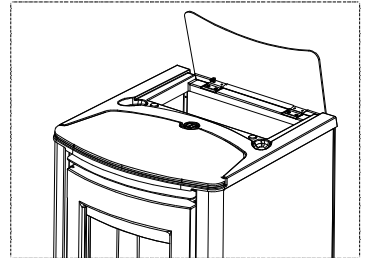

4 INSTALLATION

4.1 HEATER LOCATION



CAUTION : Always use trolleys to move the appliance and the appliance must always be in a vertical position. Follow the general guidelines set out in paragraph 1.1 to the letter. Keep in mind that the flooring of the room in which the heater is to be installed must withstand the combined weight of the appliance and the pellets contained in the tank.

CAUTION: The room in which the appliance will operate must be adequately ventilated (minimum air intake 1300 m³/h).

The appliance must be positioned at a minimum safe distance from walls and furnishings. This distance will have to be increased considerably if the objects surrounding the appliance are inflammable (matchboarding, furniture, curtains, picture frames, sofas, etc...).

The recommended minimum distances are illustrated in the drawing below on the right. Installation in the vicinity of heat-sensitive materials is only permitted if suitable insulating protection is placed between the object and the appliance (ref. Uni 10683). Adjust the mounting feet to obtain a slight gap between heater and flooring to ensure that the heater is not resting directly on the floor. It is advisable to interpose a floor protector plate between the heater and the floor if the latter is made of wood or other combustible material.

4.1.1 MOUNTING METALCOLOR CASING

Once the heater has been positioned the next step is to install the side panels and the top ceramic panel as shown in the image below on the left. The mounting sequence is as follows:

- Remove the top cast iron cover
- Insert the side panel position the bottom holes on the folds in the base and fix the 2 top screws (Figure 1A).
- Then mount the top cover and the ceramic panel.

Remember that the heater must be completely cooled down before the side panel can be cleaned with a soft cloth and water.

The casing on the Easy model is factory-mounted before delivery .



Figura 1A

LEGENDA

Isolante termico
T ispezionabile
200/450 mm se materiale combustibile
Figura / Dettaglio

KEY

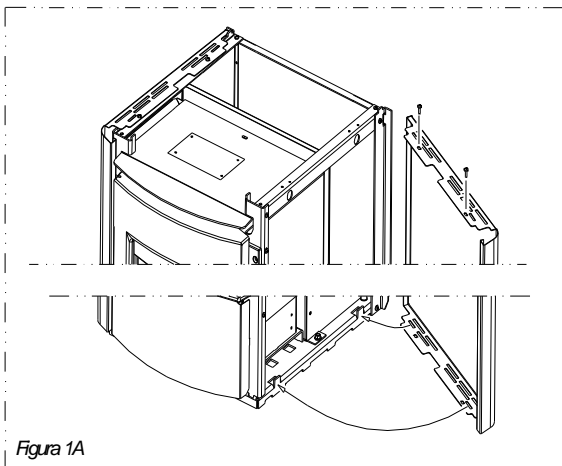
Heat insulating material
Inspectable Tee element
200/450 mm if the material is combustible
Figure / Detail

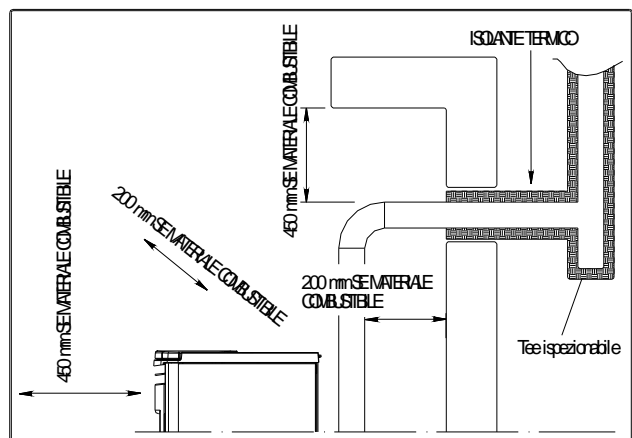

4.1.2 MOUNTING CERAMIC CASING

The next step, after positioning the heater, is to mount the ceramic casing as illustrated in the figures below.

Carry out the following operations:

- Remove the top cast iron cover (Figure 1).

- Mount the right ceramic panel supports (figure 2) following the procedure set out below:

Undo screws **A** and **B** and remove them momentarily. Fix support **SD** by firstly inserting the bottom folds on the seat of the heater base, next re-insert and fasten screws **A** and **B**. Undo screws **C** and **D** and remove them momentarily. Fix support **SSD** then re-insert and fasten screws **C** and **D**. Next screw in screws **E** and **F** provided. Screw in screws **G** and **H** provided. If the holes for the screws are not already present drill holes using a d.3.5 bit. Bend the tabs slightly (indicated in detail A of Figure 2) outwards from the heater. Next fix the side ceramics to the supports by securing them to the bent tabs. Next mount the left ceramic panel supports using the same procedure as described above for the right ceramic panel supports (Figure 2).

Next attach the side ceramic panels to the supports.

- Fix the lower front ceramic panel to its support (Figure 3) with the silicone provided; degrease and clean the ceramic panel support before gluing the parts to ensure optimal adhesion. Leave the ceramic panel in the position illustrated in Figure 3 and wait 24 hours before handling it.

- Next fasten the lower ceramic panel to the heater following the instructions set out in Figure 4.

- Lastly position ceramic top (Figure 1).



Special care must be taken when handling and mounting the ceramics in order to prevent breakages that are not covered by warranty.

Small imperfections on the surfaces of the ceramics such as: dimples, shivering and slight colour variations are normal characteristics of handcrafted ceramics which make each piece unique.



Figura 1



Figura 2

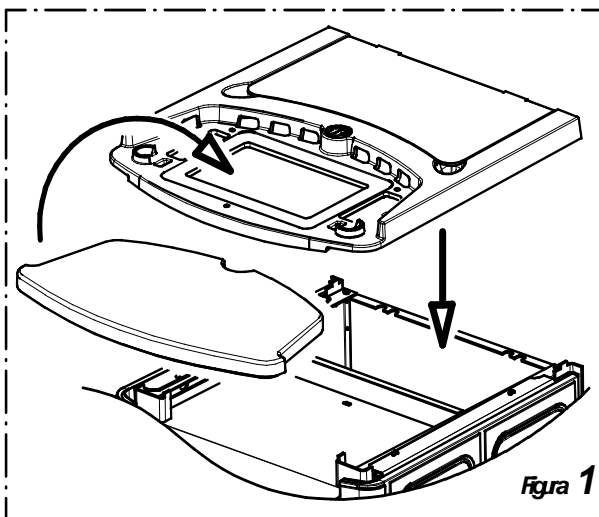

Figura 3

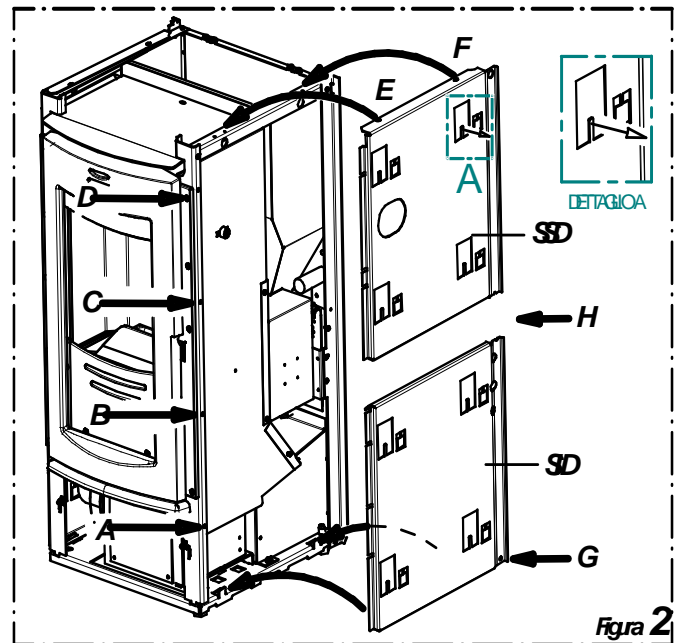

Figura 4

5 DESCRIPTION OF ECOTHERM 3001 CONTROLS

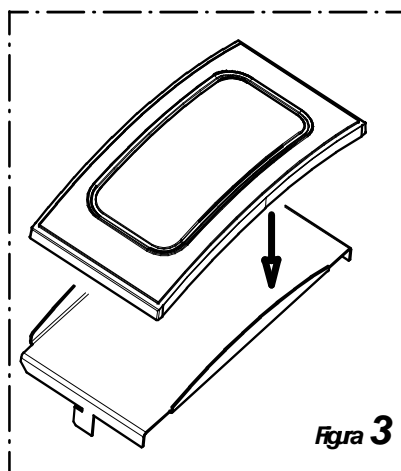
5.1 DESCRIPTION OF GREY HANDHELD RADIO CONTROL AND HEATER REAR PANEL

INTRODUCTION

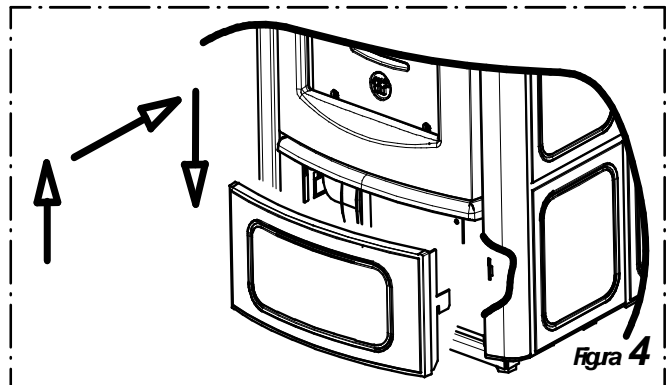
The handheld radio control is the control instrument for your heater that will permit you to manage Ecotherm and its functions. The radio control is a user-friendly way of interacting with the main heater settings and, when required, of accessing the various other control commands. In both cases the Manufacturer recommends you read the following pages carefully so that you will know how to make the best use of your heater. Keep in mind that radio wave transmissions can be affected by the surrounding environment: the presence of thick walls can reduce the transmission that normally extends to 6-7 metres.

CAUTION: to guarantee optimal data transmission it is advisable to always place the radio control in its support in a vertical position.

The following operations must be carried out the first time the heater is started up :

- Turn the switch inside the battery compartment to ON (see drawing below)

- Connect the radio control by means of the battery charger supplied to the power line, (it must be recharged for at least 5 days: see para. 8.3), as the rechargeable batteries could be partially or completely flat). Leave the radio control connected at all times, by means of the battery charger, to the power supply line. The heater must be energised and the switch turned to position "1". At the end of the winter season it is mandatory to switch off the radio control completely, by means of the switch situated inside the battery compartment, in order to preserve the life of the batteries. **The batteries are guaranteed for 6 months. When the batteries are exhausted dispose of them safely. It is normal for the temperature sensor to detect temperatures which are slightly different to the real ones: variations caused by the environment in which the radio control is positioned.**



5.1.1 HANDHELD RADIO CONTROL

A description of the buttons and indicators on the radio control follows:

The radio control consists of a plastic shell on which is installed a backlit LCD display with control buttons, interface card and rechargeable batteries: the backlighting switches off temporarily during use in order to reduce energy consumption which consequently extends the duration of the charge. There are two main control pushbuttons marked with the ventilation symbol (2) and the symbol of the flame (1). The flame button (1) sets the heater power, there are a possible 5 power levels displayed by the 5 bars progressively coming on in sequence (7). You can select the AUTOMATIC mode displayed by the text word AUTO (see paragraph 5.9). The shutdown cycle appears on the display when all the power bars are off. The fan button (2) controls the ventilation of the heater. The heater activates when the temperature exceeds 42 °C. The ventilation can be set up to 6 speed levels: when the heater is on the ventilation cannot be switched off.

Therefore, in brief, the two buttons function as follows:

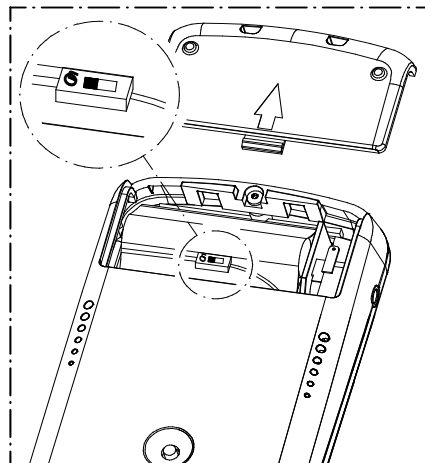
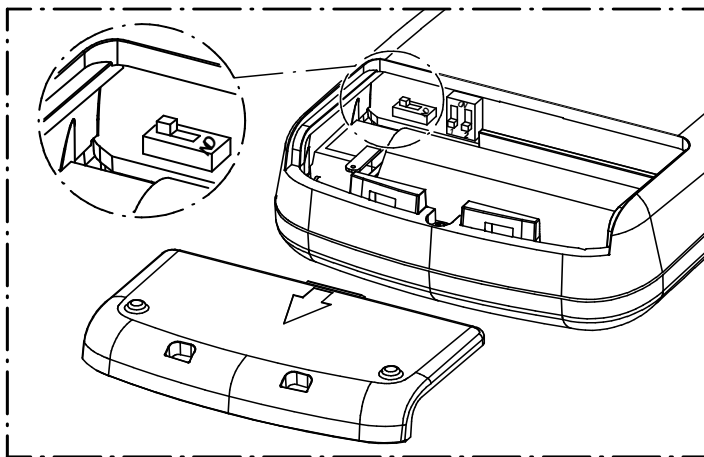

(1) Insert on/off and flame adjustment button When you press this button the appliance (10) switches to ON/ RUNNING/ OFF. Press repeatedly to activate up to 5 bars (7) and the AUTO indicator is activated (8 automatic) .

(2) Ventilation setting button Press this button to set the desired level of ventilation: up to a maximum of 6 speeds are available, indicated by the lighting of the corresponding bar (6).

5.1.2 ROOM TEMPERATURE THERMOSTAT OPERATION

When the AUTO function is activated the temperature value detected by the temperature sensor (5) installed in the radio control is updated at regular intervals. During the start up phase the temperature value is not updated. The temperature value transmitted to the heater does not change the instant there is a sudden change in the room temperature but it is updated regularly through the DATA ANALYSIS function. It is normal for the temperature sensor to detect temperatures which are slightly different to the real ones: these variations are caused by the environment in which the radio control is positioned and by the prolonged use of the display.

(3) (4) Auxiliary buttons for temperature setting

Press button 3 to lower the temperature. Press button 4 to raise the temperature level set in Aladino. As is explained below they are only functional if the AUTO cycle is selected. The set temperature appears in zone 9 of the display.

The room temperature, however, appears in zone 5 of the display. In this operating cycle the ventilation and power self-regulate according to the set temperature and the temperature detected in the display. It is not possible to set the air flow discharging from the heater at any desired temperature because it is autonomously established by the heater according to the ambient temperature. If the AUTO function is not activated the temperature value set with buttons 3 and 4 is ignored.

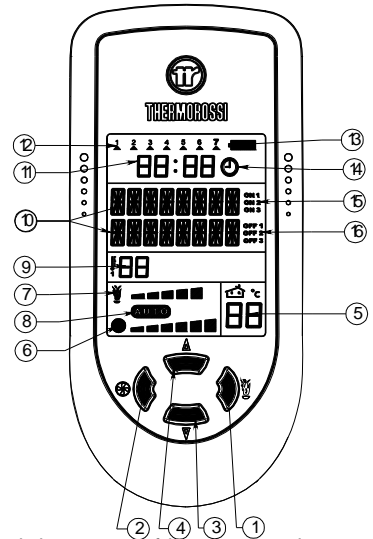

5.1.3 Indicators of the handheld radio control

(5) "Room temperature detected by the radio control's sensor indicator"

(6) "Ventilation level" indicator

(7) "Combustion level" indicator

(8) "AUTO" CYCLE ACTIVE indicator

(9) "Room temperature setting" indicator: this is the room temperature that you wish to reach by means of buttons 3 and 4.

(10) Display zone where the following appear: operating phases, programming, MENU ...

(11) Clock

(12) Day of the week

(13) Battery charge level

(14) "Chronothermostat enabled-disabled" indicator

(15) (16) On-off indicators for the programming phase

(17) Battery charger connection

(18) "Code selector" and "Battery compartment" cover

(19) "MENU" selection button To access the main menu press the button marked 19. Press button 19 repeatedly to scroll the adjustment, setting and programming windows (see para. 5.2 , 5.3 , 5.4 , 5.5 , 5.6 , 5.7) . This button can also carry out DATA ANALYSIS functions: fundamental control function for updating data.

After having carried out the DATA ANALYSIS all the data will be updated: it is normal for the temperature sensor to detect temperatures which are slightly different to the real ones: variations caused by the environment in which the radio control is positioned.

To exit the main menu without having to scroll all the possible adjustments/ functions, simply press button (1) to return to the heater operating status.

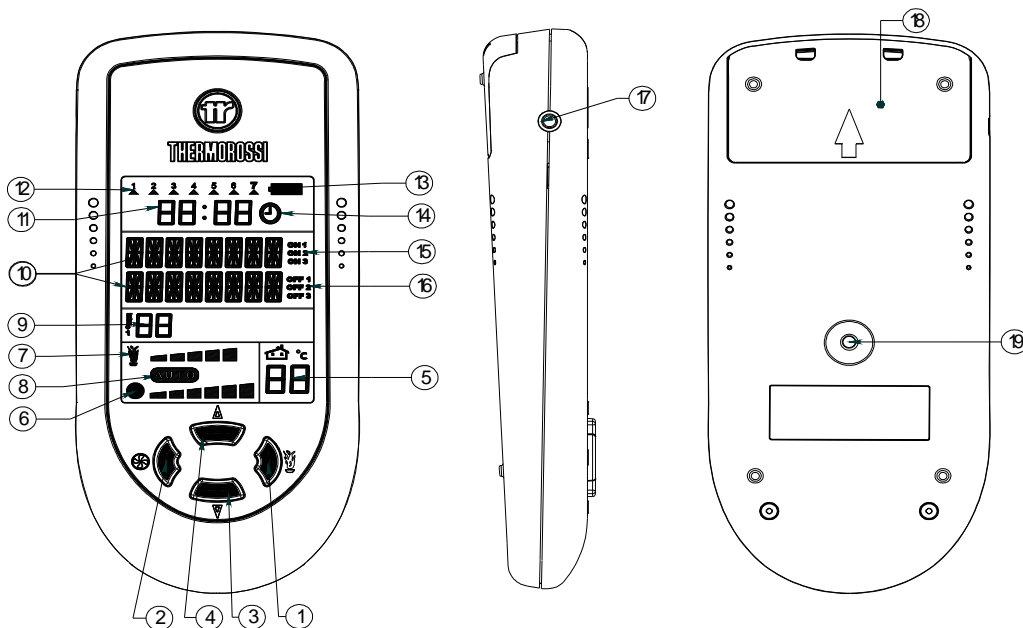

5.1.4 HEATER REAR PANEL

The rear panel integrates the radio control.
A description of the functions of the buttons and LEDs on the rear panel of the heater:

(20) Insert on/off and flame adjustment button

By pressing this button you can use the heater even without the radio control. Press button (20) repeatedly to increase the combustion power, whereas the ventilation level is adjusted automatically according to the selected combustion power. One or more acoustic signals correspond to each power step selected:

- 1 power bar -- 1 acoustic signal
- 2 power bars -- 2 acoustic signals
-
- 5 power bars -- 5 acoustic signals

If you press once again the acoustic signals will not sound: this means that after 5 seconds the heater will set itself in OFF mode and consequently shut down. It is not possible to select the AUTO cycle.

21 Loudspeaker for voice alarms/information: the heater gives information on its status and any active alarms through this loudspeaker.

22 Power outlet for additional room temperature connection.(see para. 7.1)
(additional room temperature thermostat not supplied)

23 Power outlet for additional chronothermostat connection.(see para. 7.2)
(additional chronothermostat not supplied)

24 Overtemperature thermostat button cap

In the event of overtemperature this safety thermostat stops the loading of pellets. When it is activated LED 27 comes on. To restart the heater you need to wait until it cools down, then verify the cause for the overheating, remove the cause, unscrew the protective cap and press the button (24) .

25 Electrical power outlet 220-240V 50Hz

26 Loading motor test LED.

The light must come on when the pellet screw feeder starts .

27 Reset thermostat tripped indicator light. This LED comes on when the reset thermostat is activated.

28 Main switch 0-1

29 General fuse 3.15 A

5.2 DAY AND TIME SETTING

The heater must be energised and the switch at the back turned to position "1"(see image in top right corner).

To set the clock and the day of the week carry out the procedures described below. Press the button (19) on the back of the radio control repeatedly until the word **TIME** appears.

To set the day press the button (2) . The word **DAYS** will appear on the display, and the indicator (12) will start to blink. Press the button (3) and/or (4) to set the number that corresponds to the current day.

The **1** symbol corresponds to Monday , the **2** symbol to Tuesday

..... and the symbol **7** to Sunday. To confirm the selection press the button (1).

Next the word **HOUR** will appear on the display, and the hour indicator (11) will start to blink. Press button (3) and/or (4) to set the current time. To confirm the selection press the button (1).

Next the word **MINUTES** will appear on the display and the minute indicator (11) will start to blink. Press buttons (3) and/or (4) to set the current minutes . To confirm the selection press the button (1). The day and time setting is now completed : at this point the heater operating status will appear on the display.

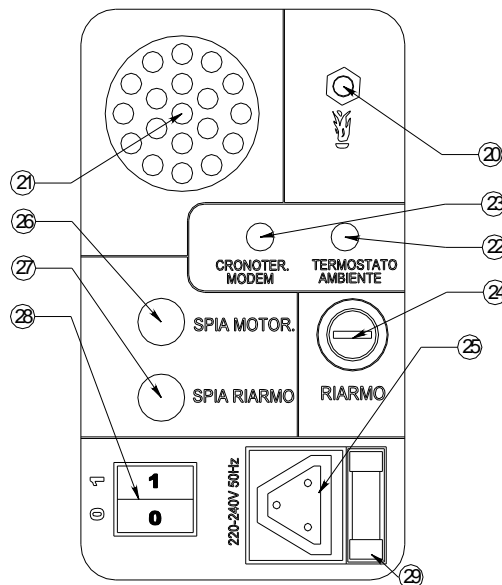

LEGENDA	KEY
Termostato ambiente	Room temperature thermostat
Cronotermostato - modem	Chronothermostat - modem
Spia Motor	Motor LED
Spia riarmo	Reset LED
Riarmo	Reset

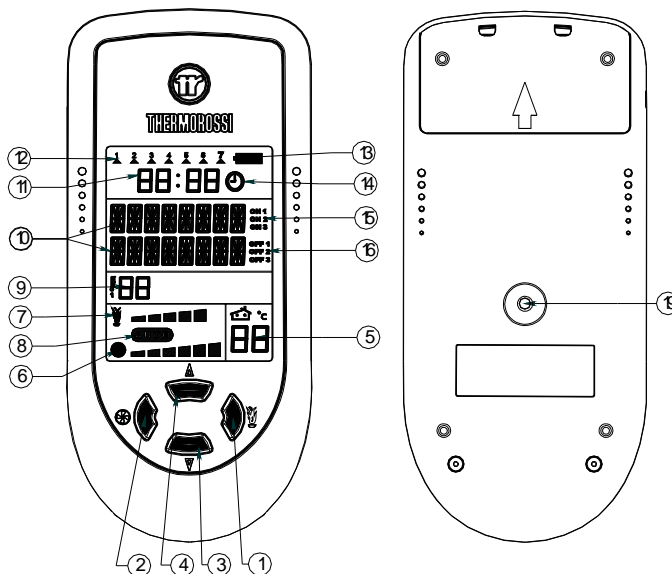

5.3 ON/OFF PROGRAMMING.

The heater must be energised and the switch at the back in position "1".
The weekly programming can be executed with the help of the handheld radio control. It is possible to set up to 3 on-off cycles for each day from Monday to Sunday. To access the programming mode press the button (19) on the back of the radio control repeatedly until the word CRONO appears.

Press button (3) or (4) to enable/disable the program setting (symbol (14) present / absent): this function is useful if you wish to disable the established weekly program setting. To program the heater you need to access the chronothermostat function by pressing the button (2): the LED 1 (12) comes on (this indicates that Monday, the first day of the week, is being programmed). The text ON1 of the indicator (15) comes on and the word HOURS appears on the display. Press button (3) and/or (4) to enter the hour of the first cycle start time. To confirm the selection press the button (1). The word MINUTES will appear on the display. Press button (3) and/or (4) to enter the minutes of the first cycle start time. To confirm the selection press the button (1). Next the text OFF1 (indicator (16) will appear on the display. Proceed using buttons (3), (4) and (1) as indicated above to set HOURS and MINUTES for the cycle end time. At this point the first on-off cycle for Monday has been entered. It is then possible to set the second on-off cycle for Monday (indicated by the texts ON2 and OFF2) and the third on-off cycle for Monday (indicated by the texts ON3 and OFF3). Now program the on-off cycles for the remaining days of the week up to and including Sunday. When the programming mode is active (⊕ symbol present) the minimum operating value at cycle on (combustion power - ventilation speed) is the same minimum operating value that was set before the last cycle off. If the second on-off cycle is not required simply set the ON2 time as 00:00 and the OFF2 time as 00:00.

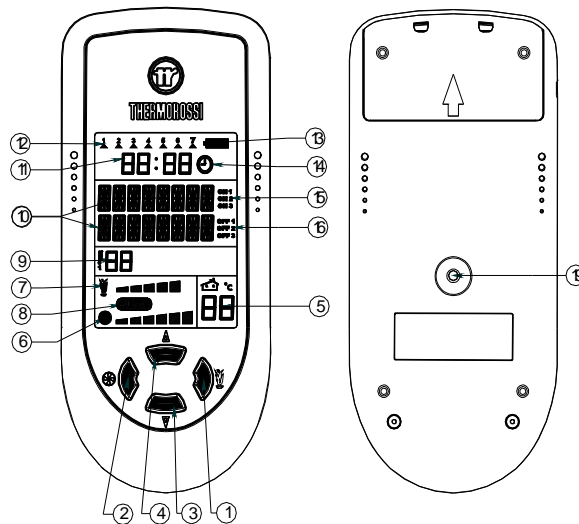

 In the event of a programmed cycle on always ensure that the brazier is clean and seated correctly in its lodging: failure to keep the brazier clean can reduce the life of the spark plug.

5.4 VOICE INFORMATION VOLUME CONTROL

The heater must be energised and the switch at the back turned to position "1".
Your heater informs you on its operating status and on any problems that could arise by means of voice messages. Select the volume level for the voice messages by carrying out the following procedure. When the insert is in the POWER OFF, POWER ON or RUNNING status simply press the button (19) until the word VOLUME appears on the display (10). Press button (2) and the word SELECT appears on the display: the introductory music plays. Press button (4) repeatedly and the + symbol appears (to increase the volume). Press button (3) repeatedly and the - symbol appears (to lower the volume). To confirm the volume selection press the button (1). The heater then returns to its previous POWER ON or RUNNING or POWER OFF status.

5.5 OPERATING LEVEL SETTING



The heater must be energised and the switch at the back turned to position "1".
Your appliance is delivered with an excellent program installed that favours combustion yield; the program is called Level 1. If you are using pellets with a higher than normal incidence of residues after combustion in the brazier, alternative levels may be selected:
Level 2 : this program increases the smoke suction unit speed acceleration.
Level 3 : this program increases the suction unit speed to a greater degree than level 2.
Level 0 : when using lightly-compressed pellets and/or flue outlets with very high vacuum, over 2 mm water column.

The pellet consumption value is not affected by the operating level settings.

Select the required level by acting as follows:

Press the (19) button on the back of the radio control repeatedly until the text indicating the preset heater level appears on the display (Level 1 or Level 2 or Level 3 or Level 0). Press the button (2) and the word SELECT appears on the display (10). To change the operating level hold down button (3) and press button (4).

By holding down button (3) and pressing button (4) repeatedly the level changes in the following sequence: Level 2... Level 3...Level 0...Level 1..., next press button (1) to confirm the selected level.

   The level selection can be made with the heater OFF or ON. If the change is made while the insert is running the difference in the flame will be apparent. It is mandatory to pay particular care when selecting the most appropriate operating cycle for your installation. After the selection of the operating cycle a thorough cleaning of the brazier is mandatory.

5.6 LANGUAGE SELECTION

The heater must be energised and the switch at the back turned to position "1".
Press the MENU' button (19) repeatedly until the word ITALIAN appears on the display (10). To change the display language proceed as follows: Press button (2) and the SELECT ITALIAN text appears on the display. Press button (4) repeatedly to select German, English, French. Once you have selected the desired language press button (1): the radio control carries out a data analysis, that is, an update of the new language.

5.7 DATA ANALYSIS

DATA ANALYSIS represents the function concerning update of data between the heater and the handheld radio control. The radio wave transmission is frequently used by numerous applications: the **DATA ANALYSIS** function is used to update the temperature, ventilation, power, temperature analysis, system status. The **DATA ANALYSIS** process can take from a minimum of 18 seconds to a maximum of 40 seconds. If the **DATA ANALYSIS** is not executed successfully, repeat the operation by pressing the button (19) for a few seconds then releasing it.

5.8 TRANSMISSION - RECEPTION ALARMS

If a problem arises with the communication between the handheld radio control and the heater the following messages could appear on the display:

OUT OF RANGE : the radio control is located at a distance that is greater than the radio control's radius of action.

NO CURRENT : the heater has shut down and does not appear to be powered by electricity.

PRESS A BUTTON : if the radius of action has been exceeded, to restore communication with the heater press one of the buttons on the radio control for approx. 2 seconds.

5.9 AUTOMATIC / MANUAL OPERATING MODE

5.9.1 DESCRIPTION OF THE AUTOMATIC OPERATING MODE CYCLE

In the automatic operating cycle the heater expresses its maximum flexibility of operation while optimising fuel consumption. During the **AUTO** cycle the heater self-regulates the combustion and ventilation according to the temperature (9) set by means of buttons (3) and (4). If for example the temperature (9) is set at 23°C the heater attempts to take the room temperature (5) detected by the handheld radio control to 23°C in the shortest possible time by modulating power and ventilation as the room temperature approaches set temperature (9). Once this temperature is reached the heater settles at the minimum operating value for combustion and ventilation. To select this function press the button (1) repeatedly until the word **AUTO** appears on the display (see image on the right). During the **POWER ON** phase, that takes 20 minutes, the heater ignores all the commands transmitted. After this time has elapsed the word **POWER ON** disappears on the delay and the word **RUNNING** appears : during this phase the **AUTOMATIC** cycle is operational. The room fan starts operating as soon as the heater body exceeds the 42°C threshold.



It is normal for the temperature sensor to detect temperatures which are slightly different to the real ones: variations caused by the environment in which the radio control is positioned.

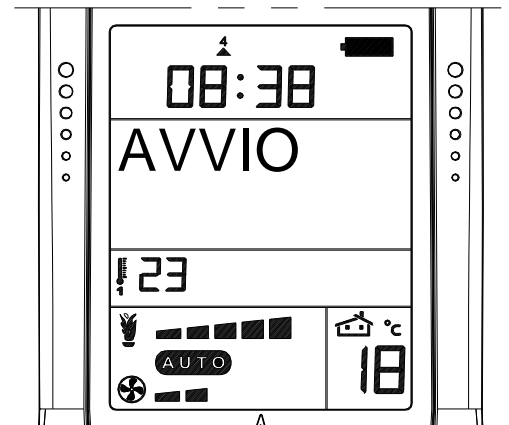

5.9.2 DESCRIPTION OF THE MANUAL OPERATING MODE CYCLE

The manual cycle is indicated by the absence of the word **AUTO** on the display. The combustion and ventilation power can be controlled independently from each other by means of the buttons (1) and (2). During the **POWER ON** phase, that takes 20 minutes, the heater ignores all the commands transmitted to it. After this time has elapsed the word **POWER ON** disappears on the delay and the word **RUNNING** appears : during this phase the **MANUAL** cycle is operational. The room fan starts operating as soon as the heater body exceeds the 42°C threshold. The combustion is regulated by 5 bars, the regulation of the ventilation is distributed on 6 steps. The room temperature thermostat is disabled when this function is operational. *It is normal that in the manual cycle the ventilation is often set at the maximum speed in order to cool the heater body more effectively.*

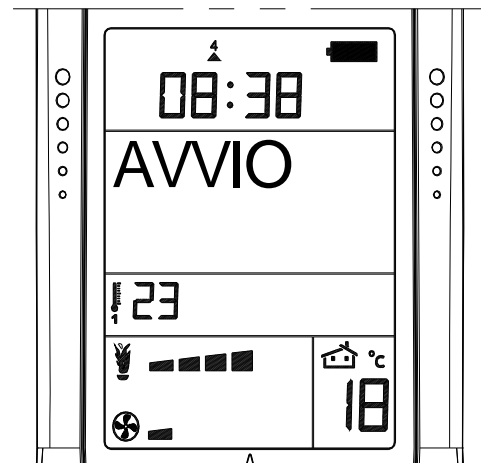

5.10 TRANSMISSION CODES SETTING

Before beginning any maintenance operation ensure that the appliance is in the OFF phase and disconnect it from the electric power outlet. When several heaters are located in rooms that are very close to each other or if there are other radio frequency controlled appliances in close vicinity it may be necessary to set different transmission codes. The change of code must be made both on the motherboard inserted in the heater (see figure below left), and in the radio control (see figure below left). Position the switch 0-1 (located on the back of the heater) on 0. To access the board you need to remove the heater's right side panel as described in para. 4.1.1 and remove the board cover by undoing the two screws as indicated in the figure below on the right.

The codes must be identical, and for this purpose you could use the numbers marked on the microswitches as reference. Firstly set the new code on the mother board, then set the new code on the radio control then execute a forced **DATA UPDATE** by repeatedly pressing button (19) located on the back of the radio control until the words **DATA ANALYSIS** appear: once the text appears hold down the button (19) for 5 seconds then release it. This procedure executes a complete resetting of the transmission codes.

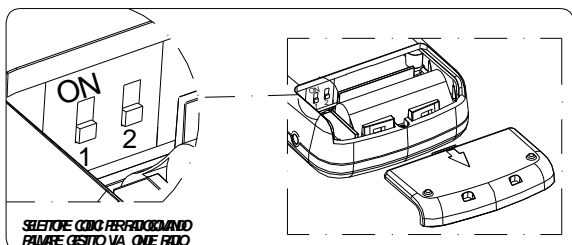

SELETORE CODICI PER RADIOCOMANDO
PALMARE GESTITO VIA ONDE RADIO

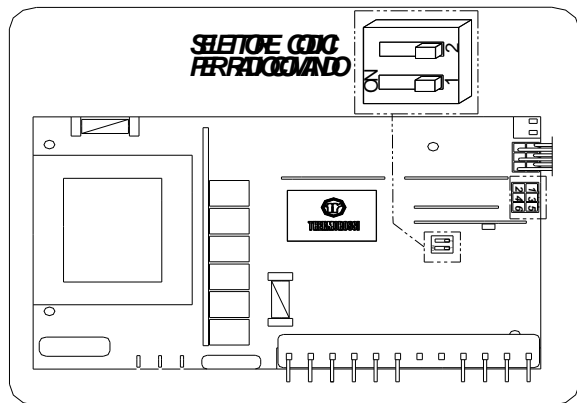

SELETORE CODICI
PER RADIOCOMANDO

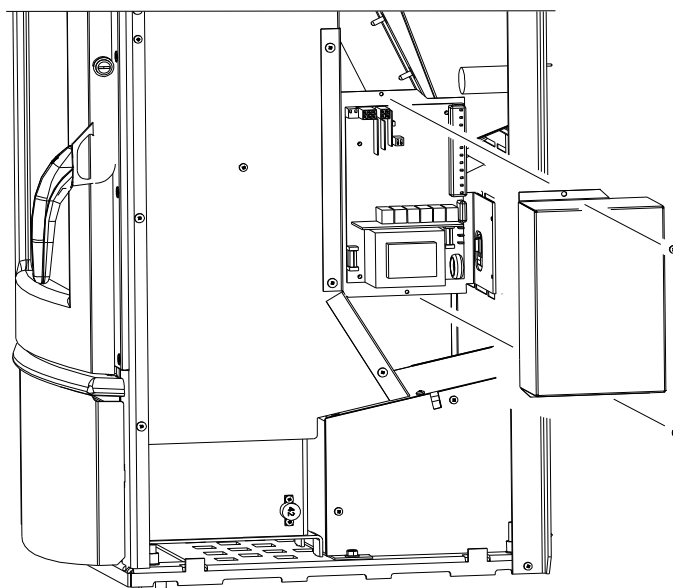

LEGENDA

Selettore codici per radiocomando

Selettore codici per radiocomando palmare gestito
via onde radio

KEY

Radio control code selector

Radio wave-controlled code selector for handheld
radio control

5.11 CARE AND MAINTENANCE OF THE RADIO CONTROL

The radio control has been designed and produced to the strictest standards and must be handled with great care.

If you observe the guidelines set out below, the radio control will provide a long trouble-free performance:

-Protect the radio control against humidity! Precipitation, humidity and liquids corrode the electronic circuits. If the radio control is wet, disconnect it immediately from a power source, remove the battery, open it and allow it to dry at room temperature.

-Do not use or store the radio control in dusty or dirty environments. The dust/dirt could damage the movable parts of the radio control.

-Do not store the radio control in very hot environments. High temperatures could shorten the life of the electronic devices, damage the batteries and deform or even melt plastic parts. -Do not store the radio control in cold environments. When it heats up (when it returns to normal operating temperature), humidity could form inside it and damage the electronic circuits.

-Do not drop the radio control, do not hit or bump it and do not shake it. Actions such as these could damage the internal circuits of the device.

-Do not use corrosive chemical substances, caustic solutions or detergents to clean the radio control.

All the above guidelines apply equally to the radio control, the battery, the battery charger, and all the accessories.

The parts subject to wear (such as batteries, keypads, lodging compartments, small compartment parts) are guaranteed for 6 months from the purchase date. The guarantee does not apply if the defect is caused by non-conforming use and/or if the instructions and guidelines described above are not observed to the letter. Non-conformities must be reported within two months of having identified them. Devices or parts returned for replacement become the property of Thermorossi.



The presence of irregular black-blue lines on the display (also present when de-energised and battery flat or missing) indicate that the glass screen of the display is damaged following a fall or impact: in this case the breakage is not covered by the guarantee.

5A DESCRIPTION OF "ECOTHERM 3001 THERMOCOMFORT" CONTROLS

5A.1 DESCRIPTION OF CONTROL PANEL AND HEATER REAR PANEL

5A.1.1 DESCRIPTION OF CONTROL PANEL

There are two main control pushbuttons marked with the ventilation symbol (2) and the symbol of the flame (1). The flame pushbutton (1) sets the power of the heater with 5 levels available which are activated as the 5 leds light up in sequence (10). The off cycle is activated when all power leds are turned off. Key (2) controls the ventilation of the heater. The heater activates when the temperature exceeds 42 °C. The ventilation can be set up to 6 speed levels (9): when the heater is on the ventilation cannot be switched off.

All controls and indicators are presented here below :

- (1) Insert on/off and flame adjustment button** When you press this button the appliance (10) switches to **Start / ON / OFF**. Up to 5 leds (10) are activated when pressed repeatedly.
- (2) Ventilation setting button** Press this button to set the desired level of ventilation: up to a maximum of 6 speeds are available, indicated by the lighting of the corresponding leds (9).
- (3) (4) Auxiliary setting keys** Keys (3) and (4) are operating keys necessary when on-off cycles are programmed, for operative levels, clock setting, etc..
- 5) Programming Enable / Disable keys**
- (6) "MENU" selection button** To access the main menu press the button marked with 6. Press button 6 repeatedly to scroll the adjustment, setting and programming windows.
- (7) Display**
- (8) Infrared sensor for remote control**
- (9) Ventilation level leds**
- (10) Combustion level leds**

LEGENDA	KEY
Termostato ambiente	Room temperature thermostat
Cronotermostato - modem	Chronothermostat - modem
Spia Motor	Motor LED
Spia riarmo	Reset LED
Riarmo	Reset

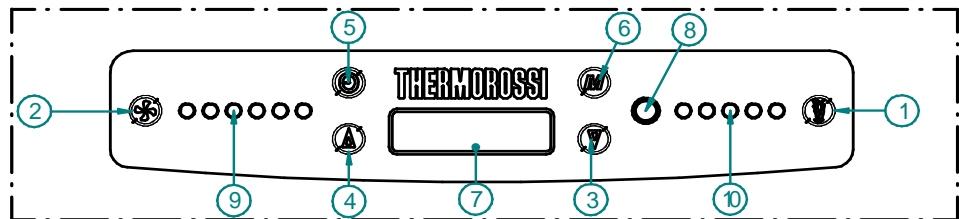

5A.1.2 REAR PANEL

A description of the functions of the buttons and LEDs on the back panel of the heater:

- (11) Main switch 0-1**
- (12) Heater electrical power outlet 220-240V 50 Hz.**
- (13) Overtemperature thermostat button cap**
In the event of overtemperature this safety thermostat stops the loading of pellets. When it is activated LED 15 comes on.
To restart the heater you need to wait until it cools down, then verify the cause for the overheating, remove the cause, unscrew the protective cap and press the button (13).
- (14) Feed motor test indicator light** When the pellet screw feeder is set in motion the light must come on.
- (15) Reset thermostat tripped indicator light.** This LED comes on when the reset thermostat is activated.
- (16) Power outlet for additional chronothermostat connection** (additional chronothermostat not supplied)
- (17) Power outlet for additional room temperature thermostat connection** (additional room temperature thermostat not supplied)

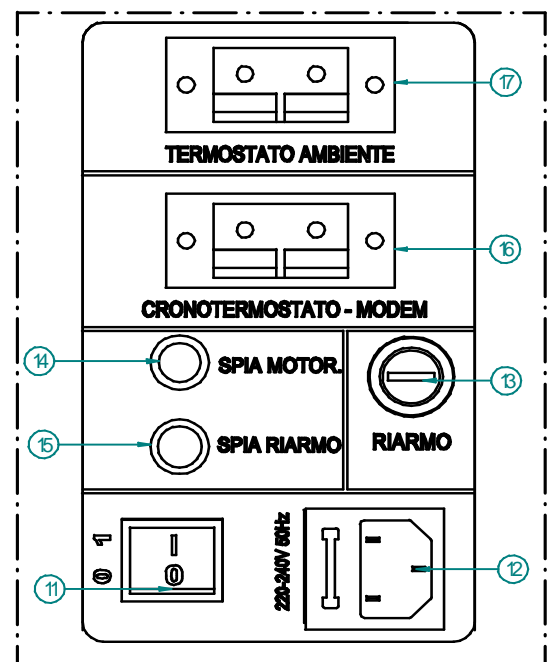

5A.2 DAY AND TIME SETTING

The heater must be fed with the rear switch in position "1". Display (7) may show the inscriptions **On** , **OFF** or **Start** .

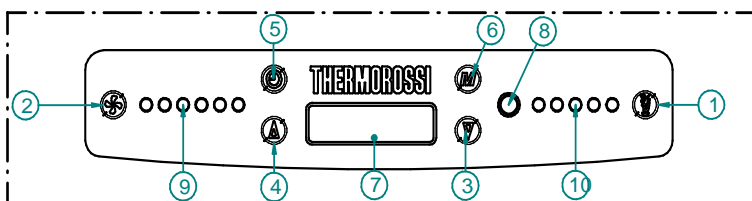

To set the time and the day of the week carry out the procedures described below. Press once the key (6), and the inscription **HoUr** will flash. After a few seconds the fixed inscription **days** will appear. In order to add just the day, repeatedly press key (4) and/or (3) until the led turns on in area (9) which corresponds to the present day; Monday is indicated by the 1st led on, Tuesday is indicated by the 2nd led on,..... Saturday is indicated by led (6) on, while Sunday corresponds to all 8 leds being on. Then confirm the day by

pressing the key (1). The 2 digits representing the hours will start flashing in the display: it is possible to select the present hour using the arrow keys (4) and/or (3); the selection must be confirmed by pressing key (1). The 2 digits indicating the minutes will start flashing: it is possible to select the present minutes using the arrow keys (4) and/or (3), the selection must be confirmed by pressing the key (1). The setting of the day and of the hour is now completed. For the entire procedure to be confirmed and to move back to the heater status display, key (6) must be repeatedly pressed until the operating status is displayed: **On**, **Off**, or **Start** .

5A.3 ON / OFF PROGRAMMING

The heater must be fed with the rear switch in position "1". Display (7) may show the inscriptions **On** , **OFF** or **Start** .

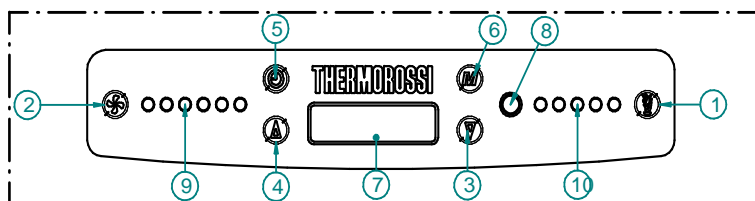

It is possible to carry out the weekly programming by setting up to 3 on/off cycles for each day from Monday to Sunday. To carry out the programming, push button (6) must be pressed twice until the inscription **cr on** is on.: in area (9) a led goes on (which indicates that the first day of the week, Monday, is being programmed). Inscription **On1** will appear on the display, and the 2 digits representing the hours will turn on. Press button (3) and/or (4) to enter the hour of the first cycle start time. To confirm the selection press the

button (1). The two digits representing the minutes will be turn on. Press button (3) and/or (4) to enter the minutes of the first cycle start time. For the selection to be confirmed press the key (1). The first hour for the Monday on-cycle has been set. Then the inscription **OFF1** will appear in the display and the two digits representing the hours will turn on. When the (3) and/or (4) is pressed the hour of the first off-cycle is entered. To confirm the selection press the button (1). The two digits representing the minutes will be turn on. By pressing the key (3) and/or (4) the minutes for the first off-cycle will be entered To confirm the selection press the button (1). At this point the first on-off cycle for Monday has been entered. Later, it is possible to set the Monday's second on-off cycle (shown with the display of **On2** and **OFF2**) and the third Monday's on-off cycle (shown with the display **On3** and **OFF3**) . Inside the programming menu, if for example the Wednesday's programming is to be changed, go to the third green led by pressing key(2): then it is possible to change the on-off programs for Wednesday, confirm the change by pressing the key (6). If the second on-off cycle is not required simply set the ON2 time as 00:00 and the OFF2 time as 00:00 .

The programming procedure ends when you confirm the last data entered by pressing button (6) or when you exiting the programming menu. Pressing pushbutton (5) programming is enabled/disabled (Enabled= message **on cr** temporarily displayed and, at the same time, a fixed point is present on the right side at the bottom of the display. Disabled= message **of cr** temporarily displayed and, at the same time, the point on the right side at the bottom of the display is not present.) : this function is useful if one wants to prevent the weekly established programming. With the programming active, the operating conditions at the start-up (combustion power – ventilation speed) are the same as set-up before the last off-cycle of the heater: this is the case if the off-cycle has been done through the programming and not through a manual action. In case the off-cycle (if carried out while the heater cycle is being controlled by the programming) is activated manually, at the next start up controlled by the programming the heater will be set at the 1st combustion power level and the 1st ventilation speed.

In order to display the present time and programmings, key (6) must be repeatedly pressed until the current time is displayed. By pressing keys (3) and/or (4) all programming values will be displayed : to exit this condition, twice press the key (6) .

▽ In the event of a programmed cycle on always ensure that the brazier is clean and seated correctly in its lodging: failure to keep the brazier clean can reduce the life of the spark plug.

LEGENDA

Presenza fissa punto

Assenza punto

Esempio di come si presenta il display con la programmazione attivata/ disattivata

KEY

Point steady presence

Point absence

Example of how the display appears with the programming activated/ deactivated.

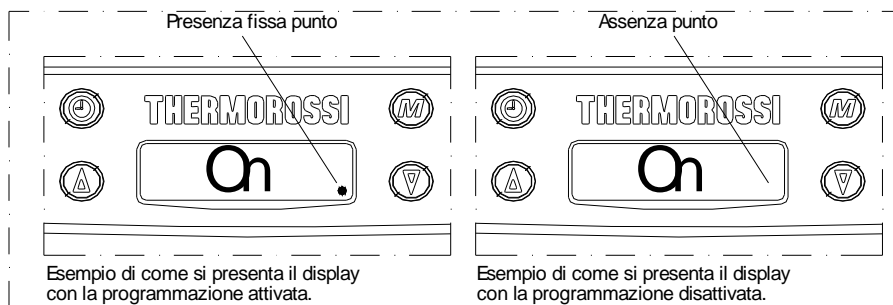



When the programming is enabled (temporary inscription **on cr** on the display and, at the same time, a fixed point is present on the right side at the bottom of the display) any additional chronothermostat (see para.7.2) is disabled.

5A.4 OPERATING LEVEL SETTING

The heater must be fed with the rear switch in position "1". Display (7) may show the inscriptions **On** , **OFF** or **Start**.

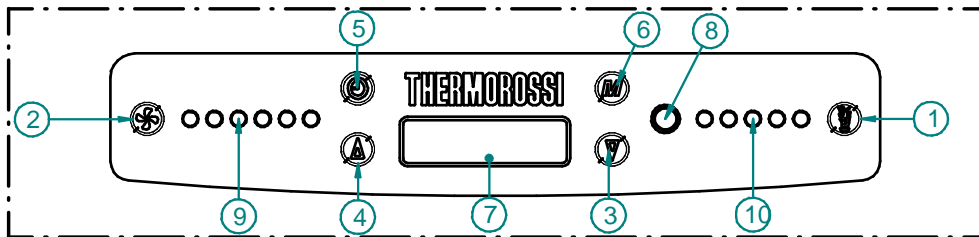

Your appliance is delivered with an excellent program installed that favours combustion yield; the program is called **P 1**.

If you are using pellets with an out-of-standard incidence of residues after combustion in the brazier, alternative levels may be selected:

P 2 : this program increases the smoke suction unit speed acceleration.

(P2program increases the air flow to the burner to improve combustion of more tightly compacted wood pellets: with this program reduces combustion efficiency).

P 0 : when using too long pellets and/or flue outlets with very high vacuum, over 2 mm water column.

The pellet consumption value is not affected by the operating level settings.

Select the required level by acting as follows:

Repeatedly press three times the key (6) until the inscription LIV flashes on the display and, then, the corresponding level set on the heater will show (P1 o P2 o P0) In order to change the operating level as key (4) is kept pressed, press the key (3).

By holding down button (4) and pressing button (3) repeatedly the level changes in the following sequence: **P2... ..P0 ... P1**.



If the change is made while the insert is running the difference in the flame will be apparent. It is mandatory to pay particular care when selecting the most appropriate operating cycle for your installation. After the selection of the operating cycle a thorough cleaning of the brazier is mandatory.

For an overall confirmation and to return to the status display of the heater, repeatedly press the key (6) until the operating status is displayed.

6 USE OF THE "ECOTHERM 3001" HEATER

6.1 5.1 SWITCHING ON THE HEATER

Before using the appliance check that all the movable parts are in place; also remove any labels and stickers from the glass to avoid having permanent traces remain on the surfaces.

Turn the switch installed on the back of the heater to position "1" (= ON). Make sure that the batteries of the handheld radio control are

charged (the symbol  indicates that the batteries are charged). If the batteries are flat it is advisable to charge them for 12 hours with the battery charger supplied. Press button (1) to start the start up phase. Press button (1) repeatedly to set **AUTO** or manual operating mode, which will be activated at the end of the start up phase.

The electrical heater will start to overheat and after a few minutes the first lot of pellets will start dropping into the brazier. This occurs because the screw feeder has to fill up because it is completely empty. The first time the heater is started up the start up phase will have to be carried out twice for this very reason.



CAUTION : The start up phase (word **ON** appearing on the display) takes 20 minutes during which the heater ignores any commands transmitted to it. After this time has elapsed the word **RUNNING** appears on the display. The fan starts as soon as the heater body exceeds 42°C. When the machine is in the running phase the combustion can be adjusted manually or in **AUTO** mode.

6.2 ADJUSTING THE HEATER'S COMBUSTION

ADJUSTING THE COMBUSTION WITH THE INSERT IN AUTOMATIC MODE

When the heater is used in **AUTO** mode the heater self-adjusts the temperature (9) set in the handheld radio control. See paragraph 5.9.1.

ADJUSTING THE COMBUSTION WITH THE INSERT IN MANUAL MODE

The thermal value is adjusted by pressing button **(1)** on the handheld radio control (see para. 5.9.2). Act on this command to adjust the quantity of pellets fed to the firebox. Maximum combustion power is achieved when all 5 bars are lit.



Caution: The fan starts as soon as the heater body exceeds 42°C. The fan setting is expressed visually by means of 6 different positions represented by 6 bars: press button (2) repeatedly to regulate it.

6.3 FILTER

This practical device prevents the circulation of dust which is always present in household environments. The filter is installed at the back of the heater (see figure on the right). Clean frequently to ensure the maximum availability of hot air when the heater is operating (wash the filter with cold water then dry thoroughly every 5 days).

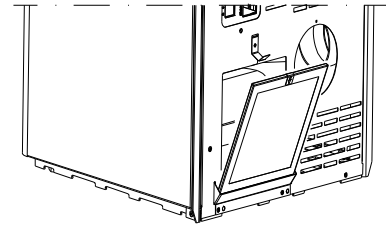

6A USE OF THE "ECOTHERM 3001 THERMOCOMFORT" HEATER

6A.1 SWITCHING ON THE HEATER

Before using the appliance check that all the movable parts are in place; also remove any labels and stickers from the glass to avoid having permanent traces remain on the surfaces.

Turn the switch installed on the back of the heater to position "1" (= ON). Press button **(1)** to start the start up phase. When key (1) is repeatedly pressed, the desired combustion level can be set and it will be active at the end of the ignition stage.

The electrical heater will start to overheat and after a few minutes the first lot of pellets will start dropping into the brazier. This occurs because the screw feeder has to fill up because it is completely empty. The first time the heater is started up the start up phase will have to be carried out twice for this very reason.



CAUTION : The start up phase (word **Start** appearing on the display) takes 20 minutes during which the heater ignores any commands transmitted to it. After this time has elapsed the word **On** appears on the display. The fan starts as soon as the heater body exceeds 42°C. During the work stage it is then possible to adjust combustion and the ventilation: Combustion is adjusted by 5 leds (through key (1)) , while the ventilation adjustment is distributed over 6 levels shown by the leds that turn on in succession (through key (2)).



To turn the heater on it is necessary for the inscription **OFF** to be present on the display; if it is not present, the key (6) must be repeatedly pressed until the inscription **OFF** appears.

6A.2 ADJUSTING THE HEATER'S COMBUSTION AND VENTILATION

The heating capacity is adjusted by pressing key (1) or on the remote control provided . Act on this command to adjust the quantity of pellets fed to the firebox. Maximum combustion power is achieved when all 5 leds are lit.



Caution: The fan starts as soon as the heater body exceeds 42°C. The fan setting is expressed visually by means of 6 different positions represented by 6 bars: press button (2) repeatedly to regulate it.
A slight vibration of the heater is quite normal when it is running.

6A.3 INFRARED CONTROL

A practical infrared remote control is supplied with the heater: press the left button to adjust the ventilation level, press the right button to adjust the combustion level. If the heater is supplied with a white radio control (optional) the infrared control only works when the MANUAL setting is set on the white handheld radio control.

6A.4 OPERATION OF THE WHITE HANDHELD RADIO CONTROL (OPTIONAL)

INTRODUCTION

The handheld radio control is the device that allows you to control Ecotherm in order to optimise consumption and its functions. Keep in mind that radio wave transmissions can be affected by the surrounding environment: the presence of thick walls can reduce the transmission that normally extends to 6-7 metres.

CAUTION: to guarantee optimal data transmission it is advisable to always place the radio control in its support in a vertical position.

The following operations must be carried out the first time the heater is started up :

- Turn the switch (11) to ON (see drawing below)
- Connect the radio control by means of the battery charger supplied to the power line, (it must be recharged for at least 5 days); as the rechargeable batteries could be partially or completely flat). Leave the radio control connected at all times, by means of the battery charger, to the power supply line. The heater must be energised and the switch turned to position "1".

At the end of the winter season it is mandatory to switch off the radio control completely, by means of the switch situated inside the battery compartment, in order to preserve the life of the batteries. The batteries are guaranteed for 6 months. When the batteries are exhausted dispose of them safely. It is normal for the temperature sensor to detect temperatures which are slightly different to the real ones: variations caused by the environment in which the radio control is positioned.



6A.4.1 Indicators of the handheld radio control

- (1) Flame adjustment button
- (2) Ventilation adjustment button
- (3) (4) Auxiliary keys
- (5) "Room temperature detected by the radio control's sensor indicator"
- (6) "Ventilation" indicator
- (7) "Combustion" indicator
- (8) "Room temperature setting" indicator : this is the room temperature that you wish to reach by means of buttons 3 and 4.
- (9) Area of the display where the operating program is displayed
- (10) Battery charge level
- (11) Switch 0-1 radio control power
- (12) Battery charger connection
- (13) Code selector and Batteries compartment cover

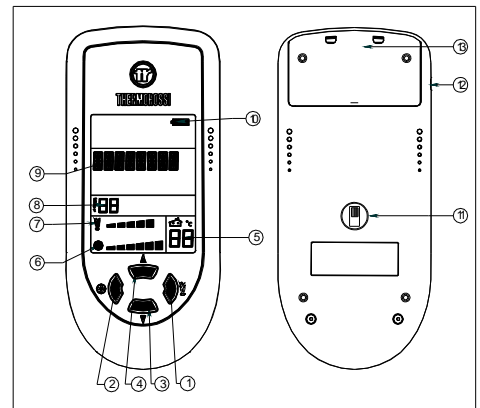

The Thermocomfort radio control can be used with 4 different operating programs:

- **Manual** (MANUAL appears in area (9) of the display)
- **Automatic 5** (AUTO 5 appears in area (9) of the display)
- **Automatic 3** (AUTO 3 appears in area (9) of the display)
- **Economy** (ECONOMY appears in area (9) of the display)

To change the operating program turn the switch (11) to "1". Press and hold down button (3) until the set program begins to blink on the display (9). Now release button (3) and press button (3) and/or (4) repeatedly until you select the desired operating program.

MANUAL program

In the MANUAL program the room temperature thermostat is disabled. Press button (1) and the flame symbol begins to blink. Press button (3) to decrease the combustion level, viceversa press button (4) to increase the combustion level. The combustion level changes with each press of buttons (3) and (4).

Press button (2) and the ventilation symbol blinks. Press button (3) and the combustion level decreases,

vice versa press button (4) to increase the combustion level. The ventilation level changes with each press of buttons (3) and (4) . Caution: it is possible that, due to radio interference, the commands sent to the heater will not be implemented.

With this program you can also use the infrared control supplied. **It is normal that in the manual cycle the ventilation is often set at the maximum speed in order to cool the heater body more effectively.**

AUTO 5 program

In program AUTO 5 the room temperature thermostat is enabled. The remote control adjusts the ventilation and combustion automatically in relation to the target room temperature set in display area (8). You can vary the desired room temperature by simply pressing button (3) and/or (4) (variation indicated in area (8)). The remote control will set the maximum combustion and ventilation levels and modulate them both as the room temperature (5) approaches the target temperature (8). When the target temperature (8) in the room (5) is reached, the combustion level will stabilise on a bar as will the ventilation level. Caution: it is possible that, due to radio interference, the commands sent to the heater will not be implemented. You cannot use the infrared control with this program.

AUTO 3 program

In program AUTO 3 the room temperature thermostat is enabled . The remote control adjusts the ventilation and combustion automatically in relation to the target room temperature set in display area (8). You can vary the desired room temperature by simply pressing button (3) and/or (4) (variation indicated in area (8)). The remote control will set the combustion power at level 3 and the ventilation at level 4 and modulate them both as the room temperature (5) approaches the target temperature (8). When the target temperature (8) in the room (5) is reached, the combustion level will stabilise on a bar as will the ventilation level. Caution: it is possible that, due to radio interference, the commands sent to the heater will not be implemented. You cannot use the infrared control with this program.

ECONOMY program

In the ECONOMY program the heater always operates at the minimum combustion level and the minimum ventilation level. You cannot use the infrared control with this program .

CAUTION: THE HEATER MUST ALWAYS BE SWITCHED ON AND OFF FROM THE CONTROL PANEL LOCATED ON THE HEATER. FOR THE RADIO CONTROL TO WORK THERE MUST NOT BE AN ACTIVE PROGRAM SET ON THE CONTROL PANEL LOCATED ON THE HEATER OR AN EXTERNAL ROOM TEMPERATURE THERMOSTAT OR AN EXTERNAL CHRONOTHERMOSTAT.

6.A.4.2 TRANSMISSION CODES SETTINGS

Before beginning any maintenance operation ensure that the appliance is in the OFF phase and disconnect it from the electric power outlet. If several heaters are installed in close locations it may be necessary to set different transmission codes. The change of code must be made both on the motherboard inserted in the heater (see figure below left), and in the radio control (see figure below left). Position the switch 0-1 (located on the back of the heater) on 0. To access the board you need to remove the heater's right side panel as described in the dedicated paragraph and remove the board cover by undoing the two screws as indicated in the figure below on the right.

The codes must be identical, and for this purpose you could use the numbers marked on the microswitches as reference. Firstly set the new code on the motherboard, next set the new code on the remote control and then switch the remote control on and off with the switch (11) located on the back of the remote control.

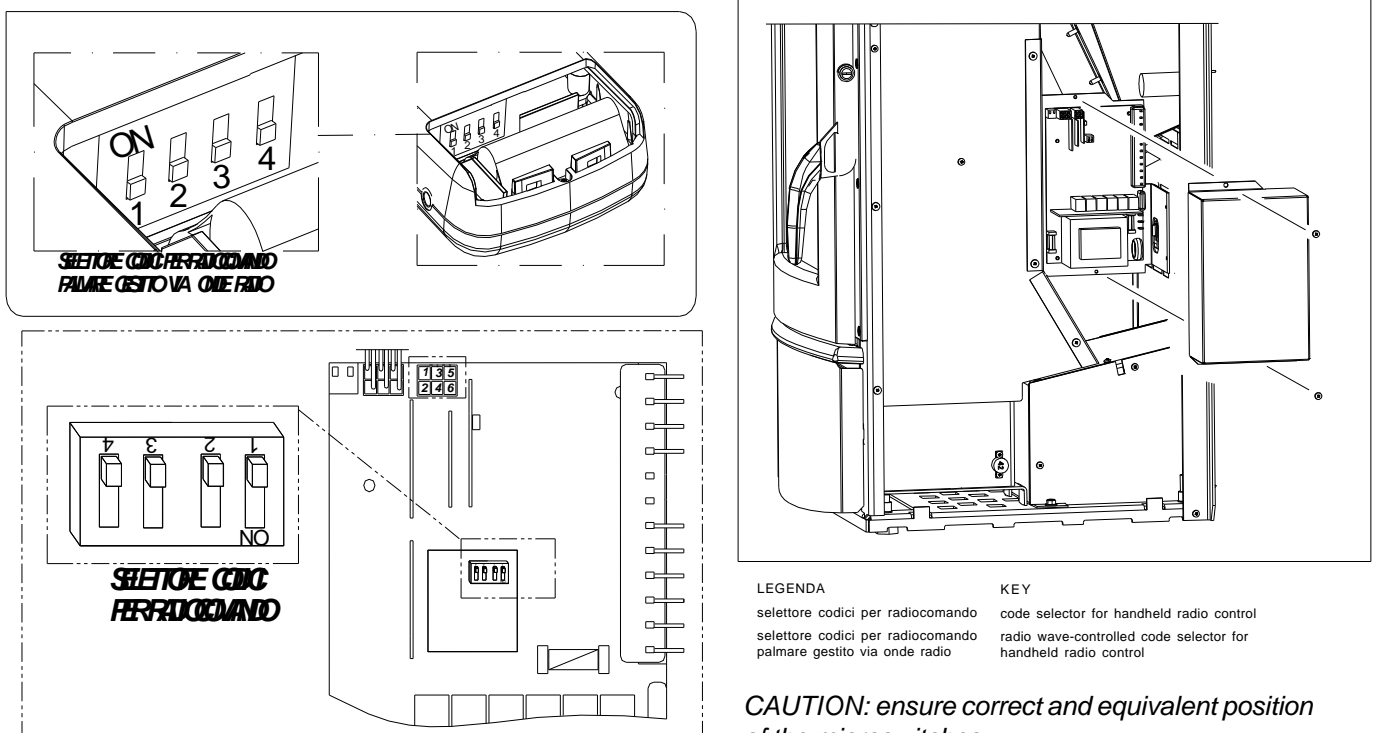

CAUTION: ensure correct and equivalent position of the microswitches.

6.A.4.3 CARE AND MAINTENANCE OF THE RADIO CONTROL

The radio control has been designed and produced to the strictest standards and must be handled with great care.

If you observe the guidelines set out below, the radio control will provide a long trouble-free performance:

- Protect the radio control against humidity! Precipitation, humidity and liquids corrode the electronic circuits. If the radio control is wet, disconnect it immediately from a power source, remove the battery, open it and allow it to dry at room temperature.
- Do not use or store the radio control in dusty or dirty environments. The dust/dirt could damage the movable parts of the radio control.
- Do not store the radio control in very hot environments. High temperatures could shorten the life of the electronic devices, damage the batteries and deform or even melt plastic parts. -Do not store the radio control in cold environments. When it heats up (when it returns to normal operating temperature), humidity could form inside it and damage the electronic circuits.
- Do not drop the radio control, do not hit or bump it and do not shake it. Actions such as these could damage the internal circuits of the device.
- Do not use corrosive chemical substances, caustic solutions or detergents to clean the radio control.

All the above guidelines apply equally to the radio control, the battery, the battery charger, and all the accessories.

The parts subject to wear (such as batteries, keypads, lodging compartments, small compartment parts) are guaranteed for 6 months from the purchase date. The guarantee does not apply if the defect is caused by non-conforming use and/or if the instructions and guidelines described above are not observed to the letter. Non-conformities must be reported within two months of having identified them. Devices or parts returned for replacement become the property of Thermorossi.



The presence of irregular black-blue lines on the display (also present when de-energised and battery flat or missing) indicate that the glass screen of the display is damaged following a fall or impact: in this case the breakage is not covered by the guarantee.

6A.4 FILTER

This practical device prevents the circulation of dust which is always present in household environments. The filter is installed at the back of the heater (see figure on the right). Clean frequently to ensure the maximum availability of hot air when the heater is operating (wash the filter with cold water then dry thoroughly every 5 days).

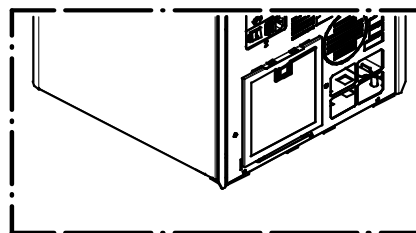

7 ADDITIONAL ROOM TEMPERATURE THERMOSTAT (not supplied) FOR "ECOTHERM 3001" ADDITIONAL CHRONOTHERMOSTAT (not supplied) FOR "ECOTHERM 3001"

The radio control ensures that your heater is provided with all the required programming and temperature adjustment functions: Two connectors are located on the back of the heater near the electric power socket.

They refer to two operating modes:

→ With the room temperature thermostat. → With the chronothermostat or modem.

In a jack the 2 wires are to be welded as illustrated in the diagram:

Use only contacts 1 and 2, do not use contact 3 .

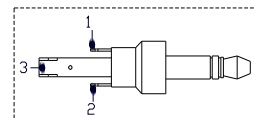

▽ Contacts 1-2 are defined as "CLEAN" contacts and must never be supplied with 220 V. If the board is powered with 220V or voltage greater than 6 V the control board will be permanently damaged; this damage is not covered by WARRANTY.

7.1 OPERATING WITH THE ADDITIONAL ROOM TEMPERATURE THERMOSTAT (NOT SUPPLIED)

It is possible to install an additional room temperature thermostat by connecting it to the back of the Ecotherm heater, by inserting a jack in the socket marked "THERMOSTAT" (see drw. para.5.4.1). This stereo jack is not supplied with the heater but is readily available in electrical or stereophonic equipment supply stores. The operating principle is as follows:

-When the room temperature reaches the set temperature (only during the RUNNING phase) the thermostat closes the contact and the heater shifts to the minimum room fan speed and minimum combustion power. By using the room temperature thermostat the heater does not shut down, therefore electrical energy consumption is kept to the minimum and the heater has a longer life.

-When the room temperature drops the thermostat opens the contact and the heater returns to its original position in terms of thermal power and ventilation.

-In this position it is not possible to start up the heater automatically or shut it down automatically.

▽ **CAUTION:** N.C. (normally closed) contacts must be used for the connection to the additional room temperature thermostat. Contacts 1-2 of the chronothermostat mod. "Perry". In the AUTO cycle the action of the additional room temperature thermostat (not supplied) is ignored.

7.2 OPERATING WITH THE ADDITIONAL CHRONOTHERMOSTAT (NOT SUPPLIED)

It is possible to install, as an alternative to the room thermostat, a chronothermostat that must be connected by means of a jack to the back of the Ecotherm heater in the socket marked "CHRONOTHERMOSTAT" (see drw. para.5.4.1). Using this outlet when the chronothermostat contact closes the ON cycle starts, whereas when the contact opens the OFF cycle starts. The operating level at start up (combustion power - fan speed) is the same as the level used before the last time the heater shut down. This operation can also occur by adjusting its room temperature. Once the desired temperature set on the chronothermostat is reached the contact opens and executes the shut down cycle. Similarly when the room temperature drops below the set temperature the contact closes and the ON cycle starts. If an unsuitable room temperature value is selected the heater will be subjected to continual ON-OFF cycles, consequently the increased number of start ups will result in greater consumption of electrical energy. The chronothermostat can be used to program temperatures, times and dates for the ON-OFF cycles. It is therefore possible to program a momentary shutting down of the heater according to the room temperature.

▽ **CAUTION:** The manufacturer denies all responsibility for the life of the electrical heater if subjected to excessive start ups. The manufacturer recommends setting a suitable room temperature value in the chronothermostat in order to prevent this possibility.

▽ **CAUTION:** Use N.O. (normally open) contacts for the connection to the chronothermostat. Contact 1-3 of the chronothermostat mod. "Perry".

▽ **CAUTION:** In the event of connections to the chronothermostat Thermorossi shall not be held responsible for the insert not starting up, smoke leaks, breakage of the lighting component. In the event of a programmed cycle on always ensure that the brazier is clean and seated correctly in its lodging.

7A ADDITIONAL ROOM TEMPERATURE THERMOSTAT (not supplied) FOR "ECOTHERM 3001 THERMOCOMFORT" ADDITIONAL CHRONOTHERMOSTAT (not supplied) FOR "ECOTHERM 3001 THERMOCOMFORT"

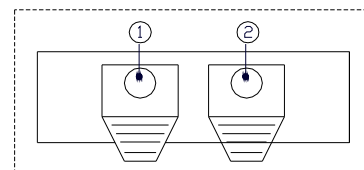

The control panel ensures that your heater is provided with all the required programming and temperature adjustment functions:

Two gland nuts are fitted to the back of the heater near the power point.

They refer to two operating modes:

→ With the room temperature thermostat. → With the chronothermostat or modem.

Simply connect the additional room temperature thermostat to the gland nut on the heater marked "Room Temperature Thermostat" or the additional chronothermostat to the gland nut on the heater marked "Chronothermostat - modem".

Use only contacts 1 and 2.



Contacts 1-2 are defined as "CLEAN" contacts and must never be supplied with 220 V. If the board is powered with 220V or voltage greater than 6 V the control board will be permanently damaged; this damage is not covered by WARRANTY.

7A.1 OPERATING WITH THE ADDITIONAL ROOM TEMPERATURE THERMOSTAT (NOT SUPPLIED)

An additional room temperature thermostat can be installed by connecting it to the cable gland marked "THERMOSTAT" at the back of the heater. The operating principle is as follows:

-When the room temperature reaches the set temperature (only during the RUNNING phase) the thermostat closes the contact and the heater shifts to the minimum room fan speed and minimum combustion power. By using the room temperature thermostat the heater does not shut down, therefore electrical energy consumption is kept to the minimum and the heater has a longer life.

-When the room temperature drops the thermostat opens the contact and the heater returns to its original position in terms of thermal power and ventilation.

-In this position it is not possible to start up the heater automatically or shut it down automatically.



CAUTION: N.C. (normally closed) contacts must be used for the connection to the additional room temperature thermostat. Contacts 1-2 of the chronothermostat mod. "Perry".

7A.2 OPERATING WITH THE ADDITIONAL CHRONOTHERMOSTAT (NOT SUPPLIED)

As an alternative to the room temperature thermostat, a chronothermostat can be installed by connecting it to the cable gland marked "CHRONOTHERMOSTAT" fitted to the back of the heater. Using this outlet when the chronothermostat contact closes the START cycle starts, whereas when the contact opens the OFF cycle starts. The operating level at start up (combustion power - fan speed) is the same as the level used before the last time the heater shut down. This operation can also occur by adjusting its room temperature. Once the desired temperature set on the chronothermostat is reached the contact opens and executes the shut down cycle. Similarly when the room temperature drops below the set temperature the contact closes and the START cycle starts. If an unsuitable room temperature value is selected the heater will be subjected to continual ON-OFF cycles, consequently the increased number of start ups will result in greater consumption of electrical energy. The chronothermostat can be used to program temperatures, times and dates for the ON-OFF cycles. It is therefore possible to program a momentary shutting down of the heater according to the room temperature.



CAUTION: The manufacturer denies all responsibility for the life of the electrical heater if subjected to excessive start ups. The manufacturer recommends setting a suitable room temperature value in the chronothermostat in order to prevent this possibility.

CAUTION: Use N.O. (normally open) contacts for the connection to the chronothermostat.

Contact 1-3 of the chronothermostat mod. "Perry".

CAUTION: In the event of connections to the chronothermostat Thermorossi shall not be held responsible for the insert not starting up, smoke leaks, breakage of the lighting component. In the event of a programmed cycle on always ensure that the brazier is clean and seated correctly in its lodging.

8 CLEANING AND MAINTENANCE

8.1 FOREWORD



Before commencing any operation disconnect the appliance from the electric power outlet. Your ECOTHERM pellet heater does not require any special maintenance; simply adhere to the simple and basic but regular controls and general cleaning. This will guarantee regular operation and optimal output at all times. If the product is unused for a prolonged period of time it is mandatory to inspect the smoke channel and outlet to ensure that there are no obstructions before use. It is necessary to accurately follow the directions given below: Otherwise severe damages may occur for the product, the installation, objects and the people who use the generator.

8.2 CLEANING AND MAINTAINING THE HEATER

- **EVERY DAY** clean out all the combustion residues from the brazier and remount the brazier and catalyst (figure 2 below).
CAUTION: make sure, before every start up, that the brazier is clean and if necessary also thoroughly clean the burner with a suction unit. Take particular care to clean the area near the spark plug : this will guarantee the correct operation of the appliance.
- **EVERY 5 DAYS** clean the room air filter located at the back of the heater (see para. 6.4).
- **EVERY WEEK** empty the ash pan "V" of all residual ash (figure 3).
- **EVERY WEEK** vacuum the residual ash from the compartment "V1" under the brazier (figure 3).
- **EVERY 2 WEEKS** clean the smoke exhaust "T" at the heater inlet .
- **EVERY MONTH** inspect and clean the vents identified as "A1" , "A2". To access vent "A2" (Figure 1), in the Easy and Metalcolor model, remove the cover "A3" by pressing the two side folds inwards and rotating it upwards. In the ceramic model to access opening A2 you must remove the lower ceramic by pushing it upwards and then pulling it outwards.
(reverse the operation illustrated in fig. 4 of para. 4.1.2).To access opening "A1" (figure 4) remove the ceramic (for the Easy model simply remove the cast iron cover as the steel plate is fixed to it), then the cast iron cover: now you can access opening "A1".
- **EVERY MONTH** check that the smoke exhaust is free from fly ash deposits, particularly in the initial sections.
- **EVERY MONTH** vacuum the ash deposited on the bottom of the tank (when the tank is empty).
- **AT THE END OF THE WINTER SEASON OR WHENEVER NECESSARY** we recommend thoroughly cleaning the Ecotherm firebox, using brushes and vacuum cleaner.
- **TWICE A YEAR** clean the smoke exhaust, including the flue outlet.

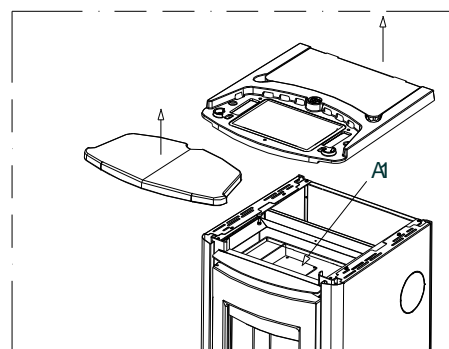
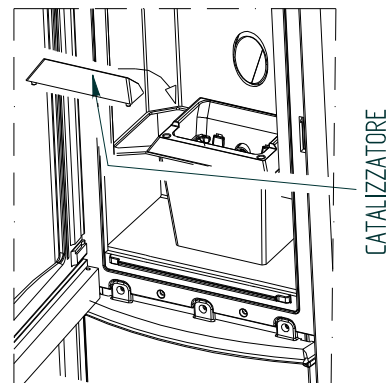
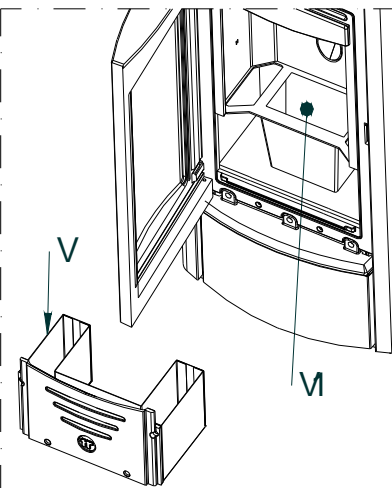
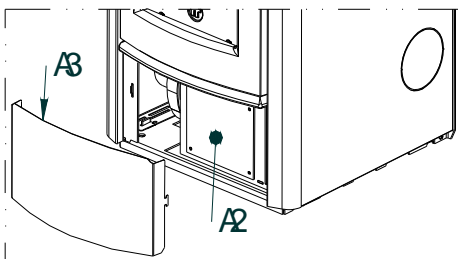

A vacuum device simplifies the cleaning procedure. Use a damp cloth or a scrunched up piece of newspaper, dampened and rolled in the ash, to wipe the glass until it is perfectly clean. Do not clean the glass while the heater is operating.

The glass remains reasonably clean if the catalyst - deviator blade is installed correctly in the brazier as shown in figure 2.

The insert must be completely cooled down before the side panel can be cleaned with a soft cloth and water.

Caution: A daily deposit of soot and combustion residues on the glass is quite normal. It is normal for the ash to fall to the floor when the door is opened.

LEGENDA	KEY
Figura	Figure
Catalizzatore	Catalyst

8.3 CHARGING THE BATTERY OF THE HANDHELD RADIO CONTROL (standard ECOTHERM 3001, optional for ECOTHERM 3001 THERMOCOMFORT)

As soon as the battery symbol on the display begins to blink, as shown in the drawing, the battery needs to be charged. While it is being charged and consequently while it is connected to the electrical power mains the battery symbol blinks continuously even when the batteries of the radio control are completely charged. This operation is necessary as otherwise the communication between the heater and the radio control could be cut off. If the communication is cut off see paragraph 5.1.4 for an explanation on how to switch off the heater with the auxiliary control located at the back of the heater. If the batteries go flat the time will have to be reprogrammed whereas the heater programming and other settings are maintained as permanent data. The batteries of the handheld radio control require regular recharging in relation to the amount of use made of it. The duration of the battery charge is variable and depends on how often the remote control is used. The batteries must be recharged using the supplied battery charger :

INPUT 100V-240V 50/60 Hz 0.3/A
OUTPUT 5.5V 750 ma

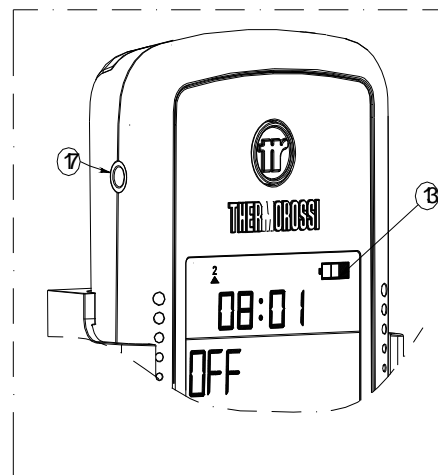

The battery charger must be connected to a 220-240V 50Hz power mains. To obtain a total recharge of the batteries they must be charged for at least 5 days: lower charge times could reduce the duration and life of the batteries. Leave the radio control connected at all times, by means of the battery charger, to the power supply line. It is completely normal for symbols and/or lines to appear haphazardly on the display while the battery is being charged. The optimal battery autonomy is achieved after several battery charge / discharge cycles. If the radio control is not used for more than one week it is mandatory to switch it off completely in order to preserve the life of the batteries. Turn the switch located in the battery compartment to 1, that is, OFF.

The batteries are guaranteed for 6 months.



Caution: Use only the battery charger provided by Thermorossi. The use of any other type of battery charger will invalidate the product warranty.

8.4 REPLACING THE BATTERY IN THE INFRARED REMOTE CONTROL (applies only to ECOTHERM 3001 THERMOCOMFORT)

When the infrared remote control does not send out the transmission signal (led on), the battery must be replaced. Use a Phillips screwdriver of proper size, to separate the half shells and replace the battery. The dead battery must be disposed of safely.

8.5 REPLACING THE BUFFER BATTERY OF THE CONTROL PANEL (applies to ECOTHERM 3001 THERMOCOMFORT)

Inside the control panel there is a buffer battery type CR2032. When time and programming are not kept in storage, the battery must be replaced using the 2 screws in the rear of the control panel. The dead battery must be disposed of safely.

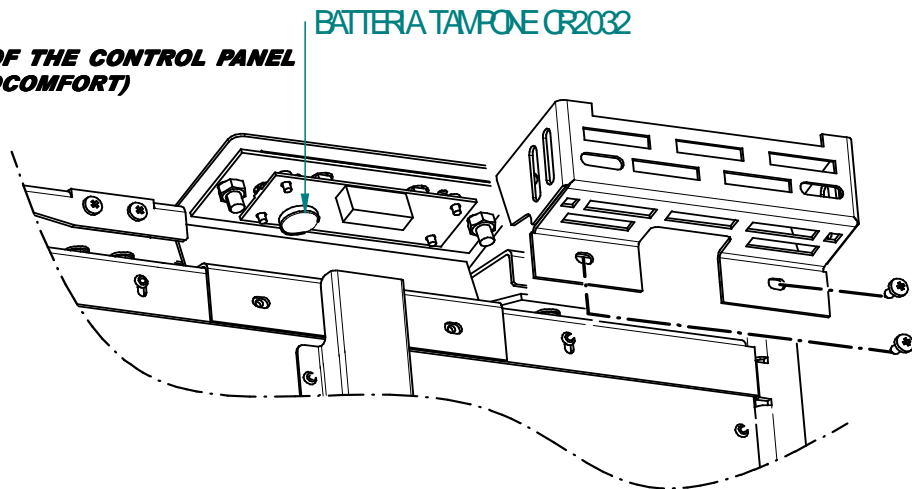

LEGENDA

Figura

Batteria tampone CR2032

KEY

Figure

Buffer battery CR2032

9 SMOKE DISCHARGE TUBE



Due to the frequent accidents caused by poor functioning of flue outlets installed in private dwellings, we have prepared the following paragraph to assist the installer in his inspection of the parts concerned with eliminating the gases produced by combustion. The gases must be discharged in compliance with UNI7129/92, UNI 10683 and EN14785. 2006. It is necessary to accurately follow the directions given below: Otherwise severe damages may occur for the product, the installation, objects and the people who use the generator.

9.1 VENTILATION OF THE ROOMS

•The room where the heater is installed must have a good air flow to guarantee secondary air for the appliance for the combustion process and for ventilation of the room. The natural air flow occurs directly through permanent apertures to the outside made in the walls of the room, or by means of single or multiple ventilation ducting.

The ventilating air must come from outside and if possible, away from sources of pollution. Indirect ventilation is also allowed by taking in air from rooms adjacent the one where the insert eater is installed taking into account all the warnings and limitations specified below.

•The apertures in the walls must comply with the following requirements:

- have an unobstructed section of at least 6cm² for each Kw of installed thermal power, with a minimum limit of 100cm²;
- be made in such a way that the vent openings, both on the inside and outside of the wall, cannot be obstructed;
- be protected with grills or similar systems in order not to reduce the section described above;
- be situated at floor-level.

•The air flow can also be obtained from an adjacent room as long as:

- the adjacent room is equipped with direct ventilation in compliance with the points described above;
- in the room to be ventilated the installed appliances are only connected to one flue outlet;
- the adjacent room is not used as a bedroom or a common area of the building;
- the adjacent room is not a room with a fire hazard, such as storage sheds, garages, combustible material store rooms, etc...;
- the adjacent room does not become a vacuum compared to the room to be ventilated due to an opposite draught effect;
- the air flow from the adjacent room to the room to be ventilated is unobstructed through the permanent apertures having an overall net section of no less than that indicated above. These apertures can be obtained by enlarging the space between the door and the floor.



This chapter is not intended to replace UNI 7129/92, UNI 10683 and EN 14785 standards to which it refers. The qualified installer must in any case be fully aware of this standard and its amending versions.

9.1.1 COMBUSTION AIR INTAKE

The air required for combustion is taken directly from the room in which the heater is installed. The room where it is installed must always be adequately ventilated (1300 m³/h) .

CAUTION: The presence of extraction fans or similar appliances, if operating in the same room or space in which the heater is installed, could cause problems for the correct operation of the heater.

9.2 SMOKE OUTLET

•The smoke exhaust shown in the following figures is the best solution to ensure the discharge of smoke even when the fan is not operational, such as for example if there is an electrical power failure. A minimum drop of 1.5 metres is required between the T terminal on the outside of the building and the outlet at the back of the appliance, to ensure that residual combustion smoke is discharged in the case described above (Otherwise the residues would stagnate inside the firebox and be discharged out to the free atmosphere).

The figures below illustrate the best solution for discharging the smoke out through the roof or into the flue outlet. If you opt to discharge the smoke out through the roof it is important to operate as shown in the figure below on the left. Insert a union tee with inspection cap, connecting brackets suitable for the height of the flue outlet, flashing that crosses the roof and chimney cap to protect against bad weather conditions. If you decide to use a classic masonry outlet see the diagram below on the right. A union tee with inspection cap and suitable supporting brackets are required. If the flue outlet is too big we recommend inserting a stainless steel or porcelain-coated steel tube with a diameter not exceeding 150mm. Seal area where the inlet and outlet part of the smoke exhaust meets the wall. **It is strictly forbidden to apply mesh to the end of the outlet tube , as it could cause the heater to malfunction** If the smoke tube is installed in a fixed position it is advisable to provide inspection openings for clean-out purposes especially in the horizontal sections. See the diagram. These openings are essential to allow for the removal of ash and unburned products which tend to accumulate along the discharge path. **The appliance functions with the firebox in a vacuum, consequently it is imperative to ensure that the discharge system is hermetically sealed.** The smoke discharge tube must be made from suitable materials such as for example:

porcelain-coated steel tubes, and the various fittings sealed with red silicone (resistant to 350°C). The outer casing of the tube must be made with insulating material (mineral wool, ceramic fiber) or use pre-insulated tubing.

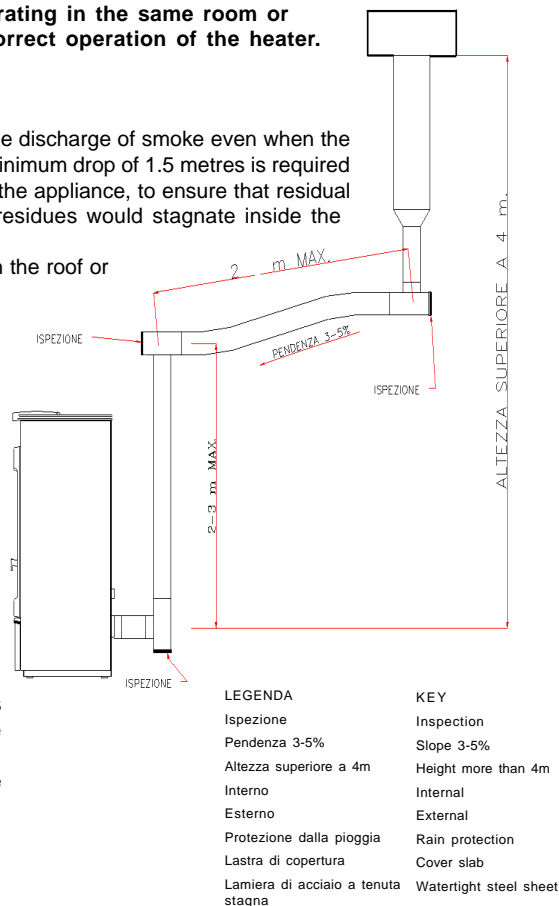

It must be possible to inspect and remove all the smoke tube sections for clean-out purposes. The appliance must always and only be installed in a single flue outlet system dedicated exclusively to the appliance. If the appliance is connected to a flue system that is non-compliant with the standards the appliance could show signs of early damage due to an anomalous continual overheating of the heater itself : in this case the damaged parts will not be replaced under warranty. The flue outlet must be able to withstand the action of a fire: in case of fire call the fire brigade immediately.



If using the side outlet (only possible with the Metalcolor model) take care not to damage the silicone tube that connects the pressure switch. In the event of a fire call the fire brigade immediately.

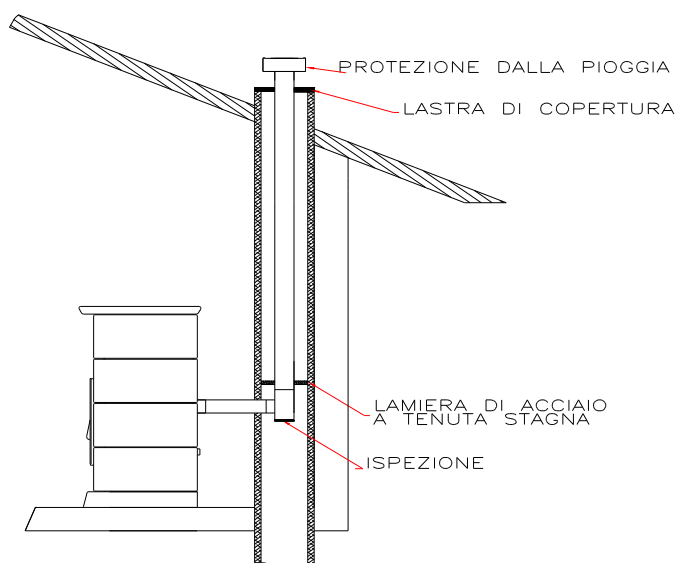
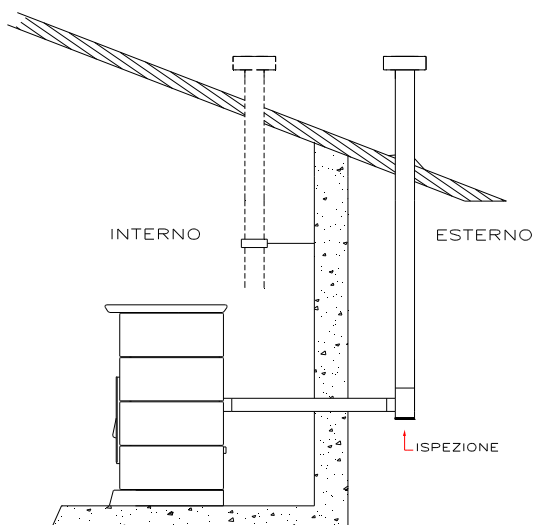

10 VOCAL ALARMS FOR ECOTHERM 3001

The heater is programmed to communicate 4 fundamental alarms. The vocal alarm is transmitted 4 times in rapid succession. It is transmitted in the following languages: Italian, English, German, French. These situations are repeated two more times a few minutes apart. If, however, the alarm is zeroed it will not be communicated.

The alarms are :

Pellets finished	+ the same alarm in the other 3 languages
Incorrect start up	+ the same alarm in the other 3 languages
General clean	+ the same alarm in the other 3 languages
Blocked smoke outlet	+ the same alarm in the other 3 languages

In detail:

Pellets finished	: is communicated when the temperature during the RUNNING mode drops below 42 °C. This indicates that the heater is switching off due to lack of pellets.
Incorrect start up	: is communicated if after the start up phase the temperature does not rise above 42°C.
General clean	: is indicated after the insert has operated for over 1800 hours.
Blocked smoke outlet	: this occurs when the smoke outlet is partially blocked. To reset the alarm press the radio control button.

10A ALARMS FOR ECOTHERM 3001 THERMOCOMFORT

The heater is programmed to communicate 3 fundamental alarms. The alarms are listed below:

AL PE	: is communicated when the temperature during the On mode drops below 42 °C. This indicates that the heater is switching off due to lack of pellets.
AL AC	: is communicated if after the start up phase the temperature does not rise above 42°C.
AL OP	: this occurs when the smoke outlet is partially blocked.

In order to set the alarms to zero, the feed to the heater must be turned off and restored using switch 0-1 on the back of the heater.

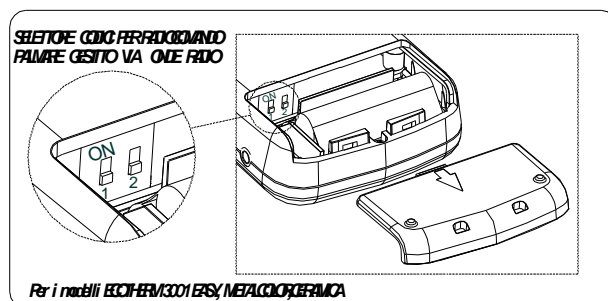

11 ELECTRICAL WIRING DIAGRAM FOR ECOTHERM 3001

If another heater is installed in the vicinity of this heater then the code selector in both the power board and the handheld radio control will have to be reset; this is necessary to prevent interferences with the operation of the two heaters. The code set in out products is standard. If you wish to alter the transmission code act on the selectors in the power board and the handheld radio control, making sure that they are set identically (see dedicated paragraph).

LEGENDA	KEY
Selettore codici per radiocomando palmare gestito via onde radio	Radio wave-controlled code selector for handheld radio control
Per i modelli ECOTHERM3001, EASY, METALCOLOR, CERAMICA	For ECOTHERM3001, EASY, METALCOLOR, CERAMIC models
Selettore codici per radiocomando	Code selector for handheld radio control
Termostato 42°/95°C	Thermostat 42°/95°C
Pressostato	Pressure switch
Termostato ambiente	Room temperature thermostat
Cronotermostato	Chronothermostat
Comando manuale retro	Rear manual control
Altoparlante	Loudspeaker
Schedina ricevitore radiocomando palmare	HANDHELD RADIO CONTROL RECEIVER CARD
Schedina trasmettitore	Transmitter board
Schedina ingresso	Input board
Schedina audio	Audio board
Resistenza	Heater
Aspiratore fumi	Smoke suction unit
Termostato riarmo manuale	Manual reset thermostat
Motore carico pellets	Pellet feed motor
Ventilatore ambiente	Room fan
Microprocessore	Microprocessor
Fusibile ventilatore 1A	Fan fuse 1A
Fusibile 1 A / 3,15 A	Fuse 1 A / 3,15 A
Schedina velocità ventilatore ambiente	Room fan speed card

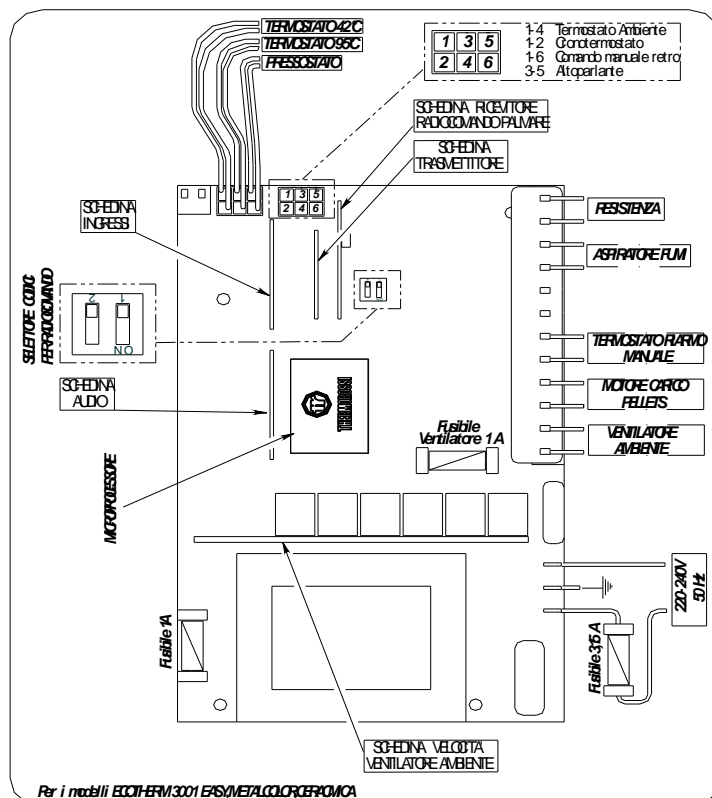

11A ELECTRICAL WIRING DIAGRAM FOR ECOTHERM 3001 THERMOCOMFORT

If another heater is installed in the vicinity of this heater then the code selector in both the power board and the handheld radio control will have to be reset; this is necessary to prevent interferences with the operation of the two heaters. The code set in our products is standard. If you wish to alter the transmission code act on the selectors in the power board and the handheld radio control, making sure that they are set identically (see dedicated paragraph).

LEGENDA	KEY
Selettore codici per radiocomando palmare gestito via onde radio	Radio wave-controlled code selector for handheld radio control
Per i modelli ECOTHERM3001 THERMOCOMFORT EASY METALCOLOR CERAMICA	For ECOTHERM3001 THERMOCOMFORT EASY METALCOLOR CERAMIC models
Selettore codici per radiocomando	Code selector for handheld radio control
Termostato 42°/95°C	Thermostat 42°/95°C
Pressostato	Pressure switch
Termostato ambiente	Room temperature thermostat
Cronotermostato	Chronothermostat
Schedina ricevitore radiocomando palmare	Handheld radio control receiver card
Resistenza	Heater
Aspiratore fumi	Smoke suction unit
Termostato riarmo manuale	Manual reset thermostat
Motore carico pellets	Pellet feed motor
Ventilatore ambiente	Room fan
Microprocessore	Microprocessor
Fusibile ventilatore 1A	Fan fuse 1A
Fusibile 1 A / 3,15 A	Fuse 1 A / 3,15 A

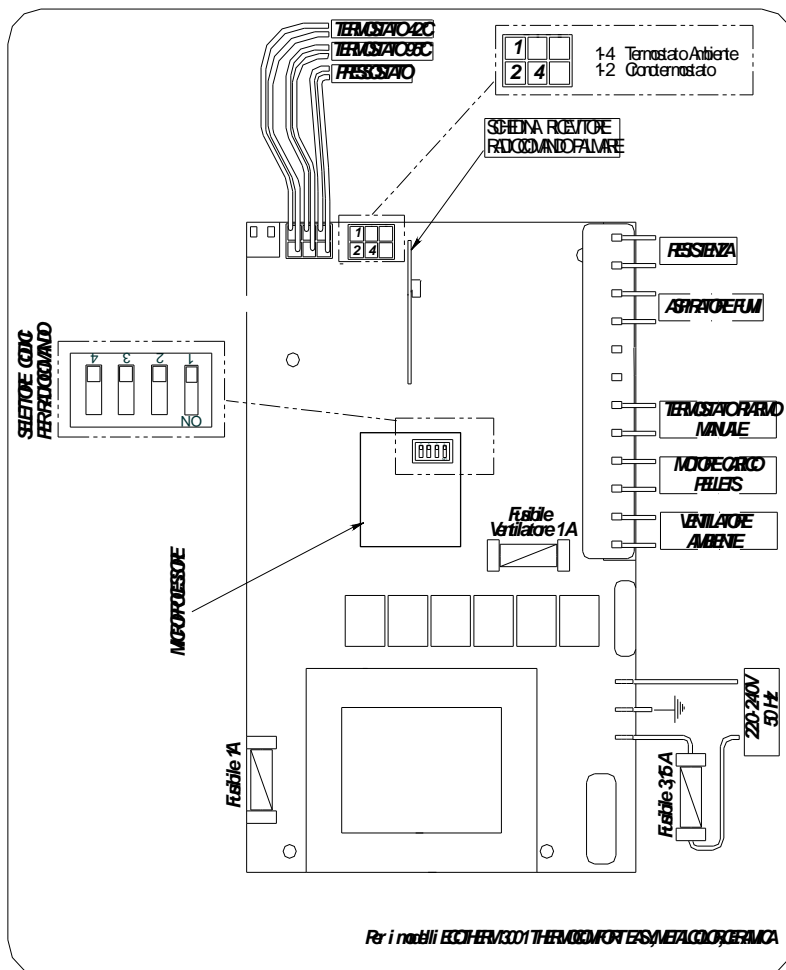
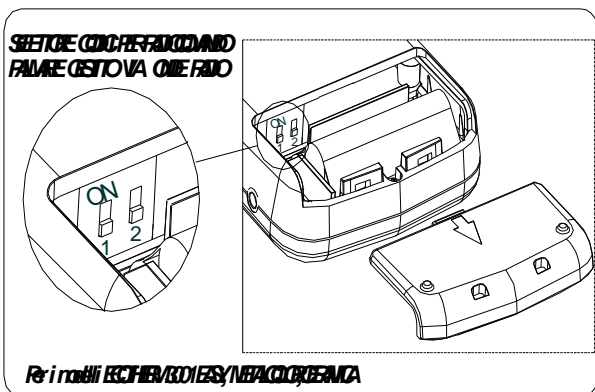

12 INFORMATION FOR THE SKILLED TECHNICIAN

12.1 MAIN COMPONENTS AND THEIR OPERATION

SMOKE PRESSURE SWITCH

This is a safety switch that stops the screw feeder motor whenever necessary. The main cause for the pressure switch tripping is a blocked flue outlet or smoke exhaust pipe. Note that it is strictly forbidden to apply any kind of mesh screen to the end of the pipe. When the holes of the mesh clog up they create a plug that trips the pressure switch which stops the pellet feeder.

SCREW FEEDER MOTOR

This motor is powered at regular on/off intervals controlled by a microprocessor. The operation of this motor is affected when:

- The motor's thermal cutout trips.
- Pellets finished.
- The manual reset thermostat trips at 125°C
- The pressure switch trips due to blocked smoke exhaust.
- The heater is switched off intentionally.

ROOM FAN

The fan starts automatically as soon as the 42°C thermostat closes the contact. The fan stops when the fuel hopper is empty or when the insert is switched off intentionally, two situations in which the thermostat's contact is opened.

SMOKE SUCTION UNIT

This is activated when the start up signal is given. In the first two minutes it «washes» the smoke discharge tube, that is, it functions at maximum working rate. Once this time has elapsed it self-adjusts to the optimal speed. The exhaust continues to operate for approximately one hour from the time the heater is switched off to allow for the evacuation of all the smoke and for safety purposes. It stops 30' after the thermostat at 42°C opens.

THERMOSTAT AT 42°C

Its function is critical for the following reasons: When the contact closes the heater powers up and the working cycle starts. Similarly, when the contact opens the smoke exhaust stops.

HOPPER SAFETY THERMOSTAT

This thermostat start operating as soon as the temperature in or near the pellet hopper approaches 85°C and sends an immediate signal to the room fan to operate at maximum power.

125°C MANUAL RESET THERMOSTAT

When the temperature exceeds 125°C the pellet feed screw shuts down. A red light at the back of the appliance remains lit. Once the causes for the overtemperature have been identified and remedied the heater can be reactivated by unscrewing the plastic cover of the thermostat located at the back of the heater and pressing the button (the heater temperature must be below 117 °C).

GLOW PLUG

It is activated in the START phase. Heats the air to 800°C, which assist the first combustion of the pellets present in the brazier.

12.2 USEFUL ADVICE FOR INSTALLATION AND OPERATION

- 1 The appliance must never be deliberately disconnected from the electric power supply. Whenever the appliance is deliberately disconnected from the electric power supply smoke could be emitted into the room and be a hazard. Similarly never switch off the appliance by suddenly cutting off the electric power supply.
- 2 Do not install the appliance with horizontal wall outlets only: evacuation of the combustion products must be guaranteed in a natural manner.
- 3 Do not install the appliance with horizontal sections only: the wall could be exposed to high wind conditions and the appliance could shut down due to back draft.
- 4 Operate the appliance at maximum for 10 hours for a complete drying and baking of the silicates contained in the enamel which covers the body of the heater.
- 5 Do not install a grill or outlet terminal which could restrain the flow of the combustion gases: this could affect the dynamic gas to the point where it would not allow the pellets to burn correctly.
- 6 Read this instruction booklet.
- 7 Keep the appliance clean and check the burner as described in this manual.
- 8 Clean the smoke outlet regularly.
- 9 Use top quality pellets: by saving 20 cents a bag you heat up to 50% less.
- 10 Maximum useable lengths of smoke exhaust tubes:
Painted aluminized steel tubes (1.5 mm minimum thickness), Aisi 316 stainless steel tubes or 0.5 mm enamelled tubes may be used.

Minimum vertical length	4 m
Maximum vertical length	8 m
Length with min slope .5%	0.5 m
Maximum number of elbows at least 0.5 m apart	2

12.3 TROUBLESHOOTING PROBLEM-CAUSE-SOLUTION (applies to ECOTHERM 3001)

PROBLEM	CAUSE	SOLUTION
PELLETS DO NOT DROP INTO THE BURNER	PELLET TANK IS EMPTY	FILL UP THE TANK
	FOREIGN BODY SUCH AS NAIL, NYLON, PIECE OF WOOD ON THE FEEDER SCREW ON THE BOTTOM OF THE TANK	REMOVE THE FOREIGN BODY
	SMOKE EXHAUST NOT FREE, OR WITH TERMINAL THAT OBSTRUCTS THE PASSAGE OF SMOKE	CHECK THE SMOKE EXHAUST AS IT COULD BE DIRTY OR CLOGGED
	OUTLET TERMINAL CLOGGED BECAUSE A GRILL OR TERMINAL HAS BEEN INSERTED WHICH PREVENTS THE FREE PASSAGE OF SMOKE	REMOVE THE TERMINAL AND REPLACE IT WITH A MORE SUITABLE ONE.
	SUDDEN GUST OF WIND WHICH HAS MADE THE HEATER GO INTO SAFETY MODE	SWITCH THE POWER SUPPLY TO THE HEATER OFF THEN BACK ON AGAIN
THE HEATER ACCUMULATES PELLETS IN THE BRAZIER WHILE OPERATING	SMOKE EXHAUST NOT FREE, OR WITH TERMINAL THAT OBSTRUCTS THE PASSAGE OF SMOKE	REMOVE THE TERMINAL AND REPLACE IT WITH A MORE SUITABLE ONE. CHECK THE SMOKE EXHAUST AS IT COULD BE DIRTY OR CLOGGED
	BURNER IS DIRTY	CLEAN THE BURNER ON A MORE FREQUENT BASIS
	PELLETS WITH DEPOSIT ABOVE PERMISSIBLE LIMITS	CLEAN THE BURNER MORE OFTEN.
	THE BURNER IS NOT PROPERLY PLACED ON ITS SEAT	SET OPERATING PROGRAMS P2 OR P3
	THE BURNER STAYS LIFTED FROM ITS SEAT	SET THE BURNER ON ITS SEAT PROPERLY
THE HEATER SMOKES	OCCURS THE FIRST TIME THE HEATER IS SWITCHED ON AS THE SILICONE PAINT IS BEING BAKED	RUN THE HEATER AT FULL POWER FOR 10 HOURS TO COMPLETE THE BAKING.
	THE SMOKE EXHAUST IS NOT SEALED CORRECTLY	MAKE SURE THAT THE GASKETS HAVE BEEN FITTED TO THE SMOKE EXHAUST PIPES
	IF THE HEATER STARTS TO SMOKE AFTER 25 MINUTES: DIRTY BURNER, VERY DELAYED START	CLEAN THE BURNER
	IF THE HEATER STARTS TO SMOKE AFTER 25 MINUTES: DELAYED START BECAUSE THE SCREW FEEDER IS EMPTY	FILL UP THE TANK
THE HEATER SHUTS OFF 5 MINUTES AFTER THE END OF THE START UP CYCLE	DELAYED START BECAUSE THE SCREW FEEDER IS EMPTY	FILL UP THE TANK
	DIRTY BURNER, VERY DELAYED START.	CLEAN THE BURNER
THE GLASS IS COVERED IN BLACK SOOT	THE HEATER ACCUMULATES PELLETS IN THE BRAZIER	SEE POINT "PROBLEM-CAUSE-SOLUTION" THE HEATER ACCUMULATES PELLETS IN THE BRAZIER WHILE OPERATING
	NO CAUSE	CLEAN THE GLASS MORE OFTEN
	THE CAST BLADE POSITION IS NOT CORRECT/NO BLADE	POSITION THE BLADE CORRECTLY/MOUNT THE BLADE
ABSENCE OF FLOW OF VENTILATION AIR	THE VENTILATION FILTER IS DIRTY	CLEAN THE VENTILATION FILTER LOCATED AT THE BACK OF THE HEATER
IT DOES NOT WARM UP	THE HEATER OPERATES AT INTERVALS.	THE HEATER MUST OPERATE FOR MORE HOURS WITH MORE POWER SEPARATE THE SPACES
	THE ROOM IS TOO LARGE, THE WALLS ARE COLD	THE HEATER SHOULD OPERATE FOR MORE HOURS AND WITH MORE POWER
	CEILINGS TOO HIGH OR PRESENCE OF STAIRS THAT DISPERSE THE HEAT ELSEWHERE	SEPARATE THE SPACES THE HEATER SHOULD OPERATE FOR MORE HOURS AND WITH MORE POWER
THE HEATER IS OFF BUT THERE ARE UNBURNT PELLETS IN THE BRAZIER	THE TANK IS EMPTY	EMPTY THE BURNER AND FILL UP THE TANK
THE HEATER CARRIES OUT RANDOM COMMANDS THAT HAVE NOT BEEN SET ON IT	THERE IS ANOTHER THERMOROSSI HEATER NEARBY	CHANGE THE CODE SELECTOR

12.4 TROUBLESHOOTING PROBLEM-CAUSE-SOLUTION (applies to ECOTHERM 3001 THERMOCOMFORT)

PROBLEM	CAUSE	SOLUTION
PELLETS DO NOT DROP INTO THE BURNER	PELLET TANK IS EMPTY (DISPLAY SHOWS THE INSCRIPTION AL PE)	FILL UP THE TANK
	FOREIGN BODY SUCH AS NAIL, NYLON, PIECE OF WOOD ON THE FEEDER SCREW ON THE BOTTOM OF THE TANK (DISPLAY SHOWS THE INSCRIPTION AL PE)	REMOVE THE FOREIGN BODY
	SMOKE EXHAUST NOT FREE, OR WITH TERMINAL THAT OBSTRUCTS THE PASSAGE OF SMOKE (DISPLAY SHOWS THE INSCRIPTION AL OP)	CHECK THE SMOKE EXHAUST AS IT COULD BE DIRTY OR CLOGGED
	OUTLET TERMINAL CLOGGED BECAUSE A GRILL OR TERMINAL HAS BEEN INSERTED WHICH PREVENTS THE FREE PASSAGE OF SMOKE (DISPLAY SHOWS THE INSCRIPTION AL OP)	REMOVE THE TERMINAL AND REPLACE IT WITH A MORE SUITABLE ONE
	SUDDEN GUST OF WIND WHICH HAS MADE THE HEATER GO INTO SAFETY MODE (DISPLAY SHOWS THE INSCRIPTION AL OP)	SWITCH THE POWER SUPPLY TO THE HEATER OFF THEN BACK ON AGAIN
	THE PELLETS SCREW MOTOR DOES NOT WORK	REPLACE THE PELLETS SCREW MOTOR
	THE RESET THERMOSTAT TRIPS AND LOCKS THE GEARMOTOR	THE ROOM FAN IS BROKEN AND MUST BE REPLACED; THEN PUT BACK INTO SERVICE THE RESET THERMOSTAT; WAIT UNTIL THE HEATER COOLS DOWN AND RESET THE THERMOSTAT THE VENTILATION FILTER IS VERY DIRTY AND MUST BE CLEANED; THEN, PUT BACK INTO SERVICE THE RESET THERMOSTAT; WAIT UNTIL THE HEATER COOLS DOWN AND RESET THE THERMOSTAT
THE HEATER ACCUMULATES PELLETS IN THE BRAZIER WHILE OPERATING	SMOKE EXHAUST NOT FREE, OR WITH TERMINAL THAT OBSTRUCTS THE PASSAGE OF SMOKE	REMOVE THE TERMINAL AND REPLACE IT WITH A MORE SUITABLE ONE. CHECK THE SMOKE EXHAUST AS IT COULD BE DIRTY OR CLOGGED
	BURNER IS DIRTY	CLEAN THE BURNER ON A MORE FREQUENT BASIS CARRY OUT ALL CLEANING OPERATIONS INDICATED IN PARA. 8.2
	PELLETS WITH DEPOSIT ABOVE PERMISSIBLE LIMITS	CLEAN THE BURNER MORE OFTEN. SET OPERATING PROGRAMS P2
	THE BURNER IS NOT PROPERLY PLACED ON ITS SEAT	SET THE BURNER ON ITS SEAT PROPERLY
	THE BURNER STAYS LIFTED FROM ITS SEAT	SET THE BURNER ON ITS SEAT PROPERLY
THE HEATER SMOKES	OCCURS THE FIRST TIME THE HEATER IS SWITCHED ON AS THE SILICONE PAINT IS BEING BAKED	RUN THE HEATER AT FULL POWER FOR 10 HOURS TO COMPLETE THE BAKING
	THE SMOKE EXHAUST IS NOT INSTALLED CORRECTLY	MAKE SURE THAT THE GASKETS HAVE BEEN FITTED TO THE SMOKE EXHAUST
	IF THE HEATER STARTS TO SMOKE AFTER 10 MINUTES: DIRTY BURNER, VERY DELAYED START	CLEAN THE BURNER
	IF THE HEATER STARTS TO SMOKE AFTER 25 MINUTES: DELAYED START BECAUSE THE SCREW FEEDER IS EMPTY	FILL UP THE TANK
THE HEATER SHUTS OFF 5 MINUTES	DELAYED START BECAUSE THE SCREW FEEDER IS EMPTY (DISPLAY SHOWS THE INSCRIPTION AL AC)	FILL UP THE TANK
	DIRTY BURNER, VERY DELAYED START	CLEAN THE BURNER



LEGENDA

Cuoio
Nera
Beige
Rosso/a
Easy
Inox
(Sx con asole)
(Dx con asole)

Porta Completa
Porta Ghisa
Vetro
Guarnizioni
Maniglia acciaio
Semiguscio anteriore / posteriore
Term. 95 °C / 42 °C

ECO 3001 fino matr. 1042044068
ECO 3001 da matr. 1042044068,
Thermocomfort
Condensat.
Condensatore

KEY

Leather
Black
Beige
Red
Easy
Stainless steel
(LH with slots)
(RH with slots)

Complete door
Cast door
Glass
Gaskets
Steel handle
Front / back handle cover
Therm. 95 °C / 42 °C

ECO 3001 to serial no. 1042044068
ECO 3001 from serial no. 1042044068,
Thermocomfort
Condens.
Condenser

13 SPARE PARTS

13.1 SPARE PARTS FOR "ECOTHERM 3001" AND "ECOTHERM 3001 THERMOCOMFORT"

See key on page 35

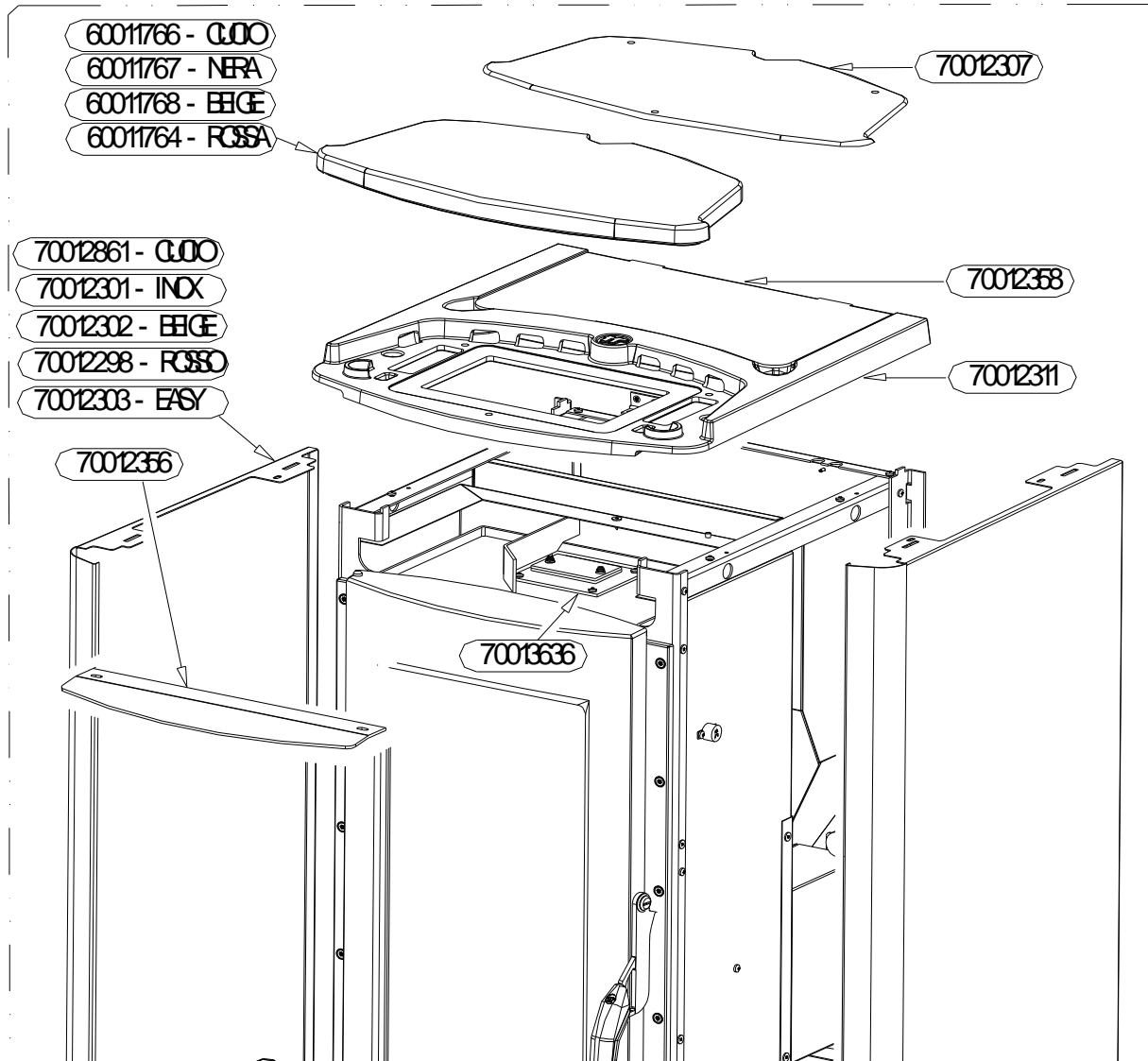

13.2 SPARE PARTS FOR ALL "ECOTHERM 3001" AND "ECOTHERM 3001 THERMOCOMFORT"

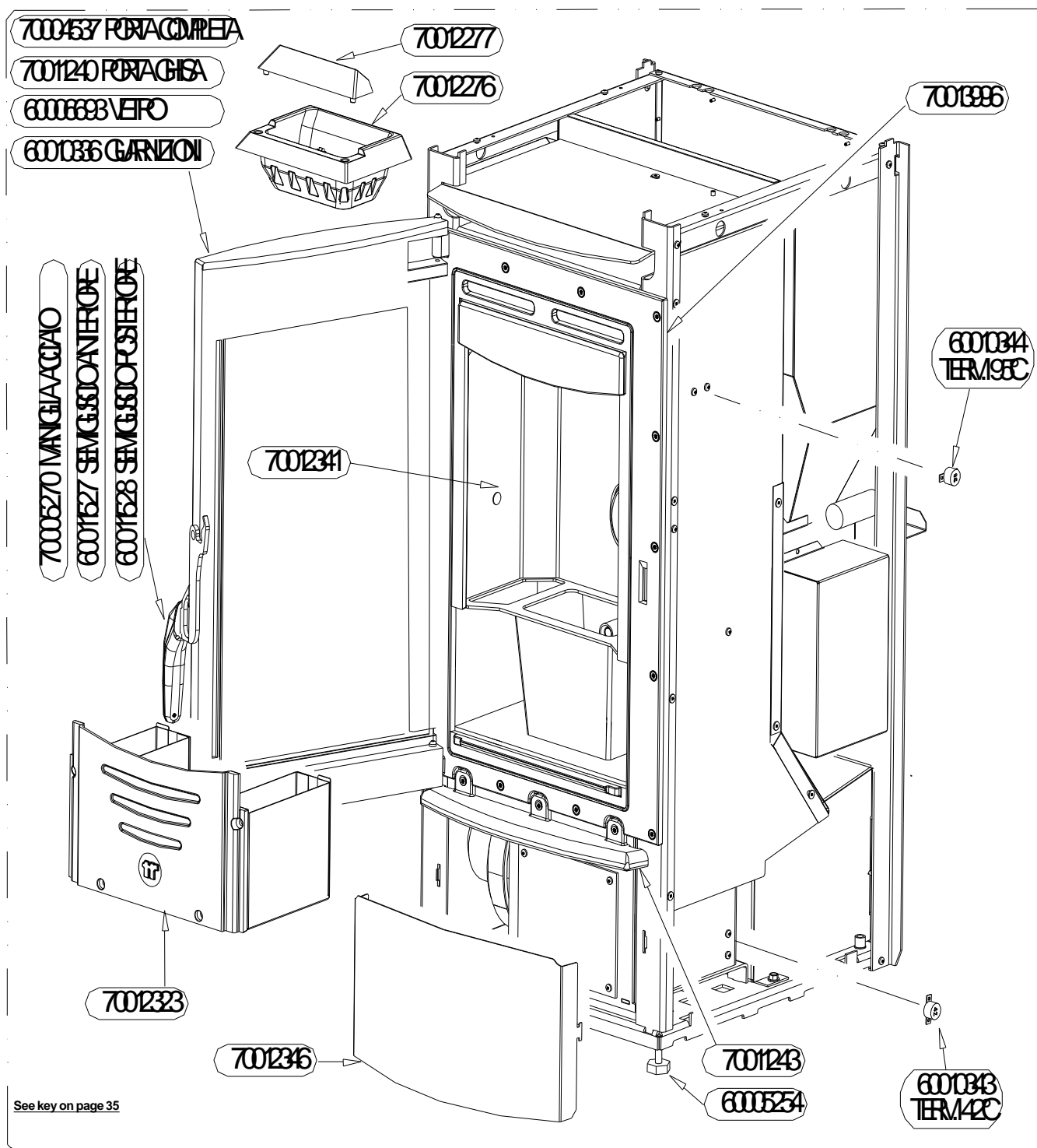

See key on page 35

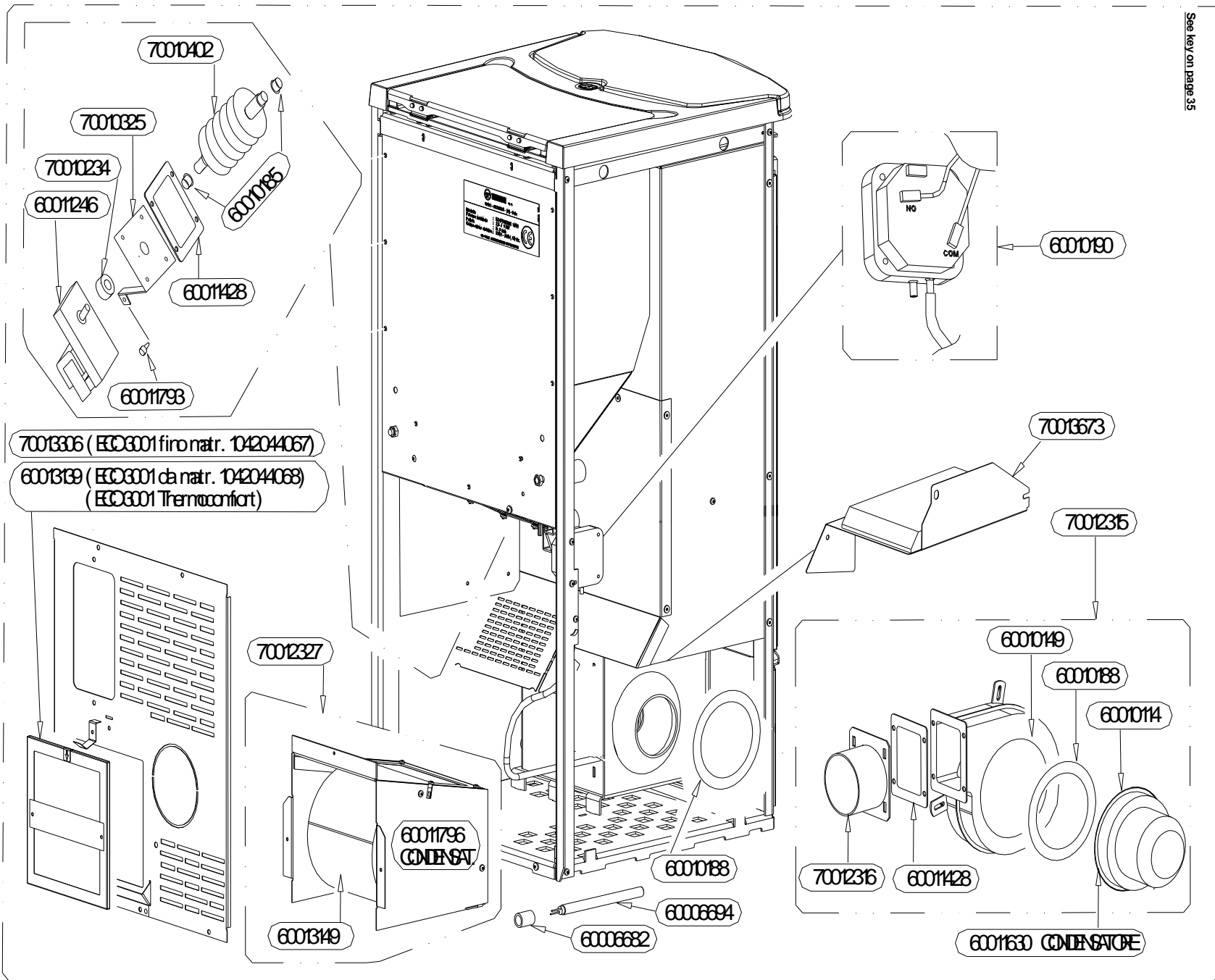

13.4 SPARE PARTS FOR "ECOTHERM 3001" AND "ECOTHERM 3001 THERMOCOMFORT"

See key on page 35

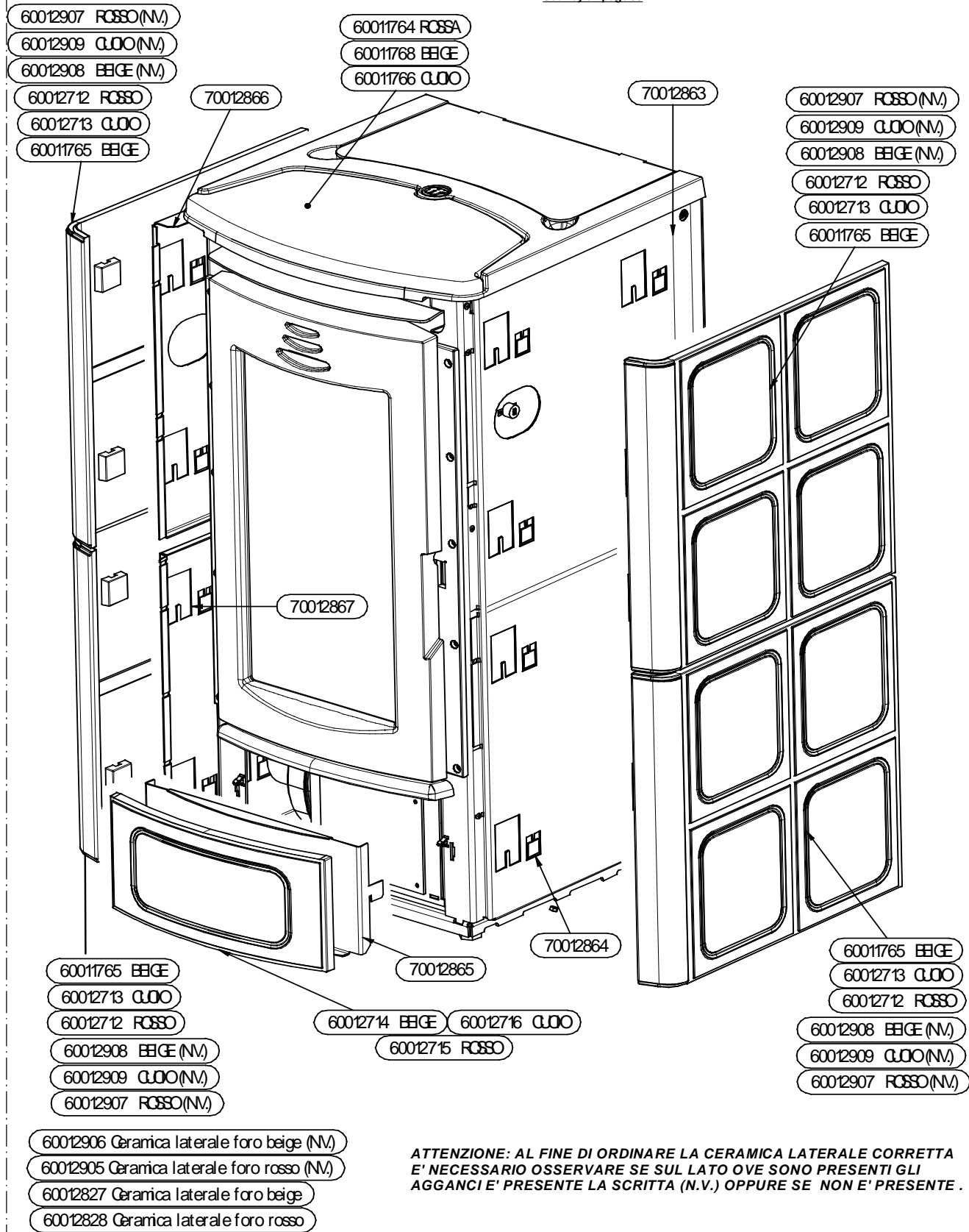

13.5 SPARE PARTS FOR "ECOTHERM 3001"

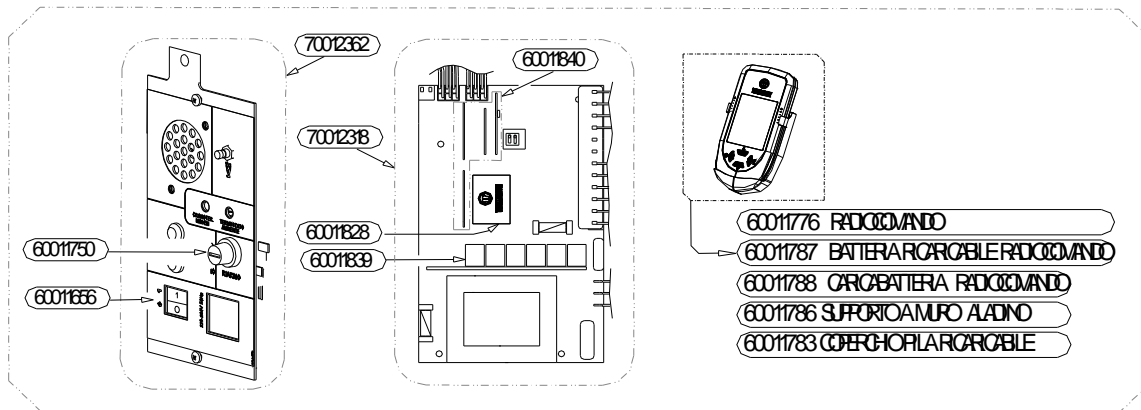

13.6 SPARE PARTS FOR "ECOTHERM 3001 THERMOCOMFORT"

LEGENDA

CUOIO
NERA
ROSSO/A
BEIGE
SX CON ASOLE
DX CON ASOLE
PORTA COMPLETA
PORTA GHISA
VETRO
GUARNIZIONI
MANIGLIA ACCIAIO
SEMIGUSCIO ANTERIORE
SEMIGUSCIO POSTERIORE
TERM 95°C
..fino matr.
da matr.

CONDENSATORE

Ceramica laterale foro beige / rosso (NV)

Attenzione: al fine di ordinare la ceramica laterale corretta è necessario osservare se sul lato ove sono presenti gli agganci è presente la scritta (N.V.) oppure se non è presente

Radiocomando

Batteria ricaricabile radiocomando
Caricabatteria radiocomando
Supporto a muro Aladino
Coperchio pila ricaricabile
Pannello
Targhetta
Batteria CR2032
Easy
Metalcolor - Ceramica
Pannello
Termostato riarmo
Interruttore 0-1
Radiocomando completo
Batteria ricaricabile
Carica batteria
Supporto a muro
Coperchio Batteria

KEY

LEATHER
BLACK
RED
BEIGE
LH WITH SLOTS
RH WITH SLOTS
COMPLETE DOOR
CAST DOOR
GLASS
GASKETS
STEEL HANDLE
FRONT HANDLE COVER
BACK HANDLE COVER
THERM 95°C
..to serial no.
from serial no.

CONDENSER

Side ceramic with hole beige / red (NV)

Caution: To order the correct side ceramic check whether the letters (N.V.) are present or not on the side with the hooks

Radio control

Radio control rechargeable battery
Radio control battery charger
Aladino wall bracket
Rechargeable battery cover
Panel
Tag
Battery CR2032
Easy
Metalcolor - Ceramic
Panel
Reset thermostat
Switch 0-1
Complete radio control
Rechargeable battery
Battery charger
Wall mount
Batter cover

