

WARNING

This information is a copy of an original archive, therefore Aga cannot be held responsible for its continued accuracy.

THE COALBROOKDALE GS3i

Natural Gas Model

Installation and Servicing Instructions

CE Cat I_{2H} (G20) For use in GB and IE at a supply pressure of 20mbar

Consumer Protection Act 1987

As manufacturers and suppliers of cooking and heating products, in compliance with Section 10 of the Consumer Protection Act 1987, we take every care to ensure, as far as is reasonably practicable, that these products are so designed and constructed as to meet the general safety requirement when properly used and installed. To this end, our products are thoroughly tested and examined before despatch.

IMPORTANT NOTICE: Any alteration that is not approved by Aga-Rayburn could invalidate the approval of the appliance, operation of the warranty and could also affect your statutory rights.

Control of Substances - Health and Safety Important

This appliance may contain some of the materials that are indicated. It is the Users/Installers responsibility to ensure that the necessary

personal protective clothing is worn when

handling where applicable, the pertinent parts that contain any of the listed materials that could be interpreted as being injurious to health and safety, see below for information.

Firebricks, Fuel beds, Artificial Fuels - when handling use disposable gloves.

Fire cement - when handling use disposable gloves.

Glues and Sealants - exercise caution - if these are still in liquid form use face mask and disposable gloves.

Glass Yarn, Mineral Wool, Insulation Pads, Ceramic Fibre, Kerosene Oil - may be harmful if inhaled. May be irritating to skin, eyes, nose and throat. When handling avoid contact with skin or eyes. Use disposable gloves, face-masks and eye protection. After handling wash hands and other exposed parts. When disposing of the product, reduce dust with water spray, ensure that parts are securely wrapped.

GAS DATA

GAS DATA	
	NAT GAS (G20)
MAX	kW
HEAT INPUT (GROSS)	11.8
HEAT OUTPUT (GROSS)	7.1
MIN	kW
HEAT INPUT (GROSS)	5.00
HEAT OUTPUT (GROSS)	2.25

Gas Connection 8mm OD Tubing

Flue Spigot size - 125mm

Ignition - piezo spark ignitor

Spark Gap 2.5 - 4mm (factory set non-adjustable)

Appliance weight 115kg

INTRODUCTION

The Coalbrookdale GS3i is factory set to operate on **natural gas only** and **must not** be used on any other gas.

Due to the newness the stove may give off a slight smell for a short period after commissioning. This is quite normal and will disappear after a few hours operation, open windows and doors if required.

The Coalbrookdale GS3i has one access door as part of its design. The glass fronted door is for access to the coals and apart from initial commissioning of the stove, or in case the pilot is required be lit with a taper due to malfunction of the spark ignition system.

UNDER NO CIRCUMSTANCES MUST THE STOVE BE OPERATED WITH THE DOOR OPEN OR IF ANY OF THE CLASS PANELS ARE CRACKED OR BROKEN.

The Coalbrookdale GS3i has been designed similar to a solid fuel stove to relevant safety standards, but during use, many parts of the appliance can become **HOT** to touch. We recommend that you provide and secure a fireguard complying with BS.6539 when the room is used by elderly, infirm or young persons.

SETTING PRESSURE (COLD)

SETTING PRESSURE (COLD)
NATURAL
MAX
mbar
14.2 ±0.75
Burner Injector Nat-Cat 82/900
Pilot Injector Nat-NG 9005

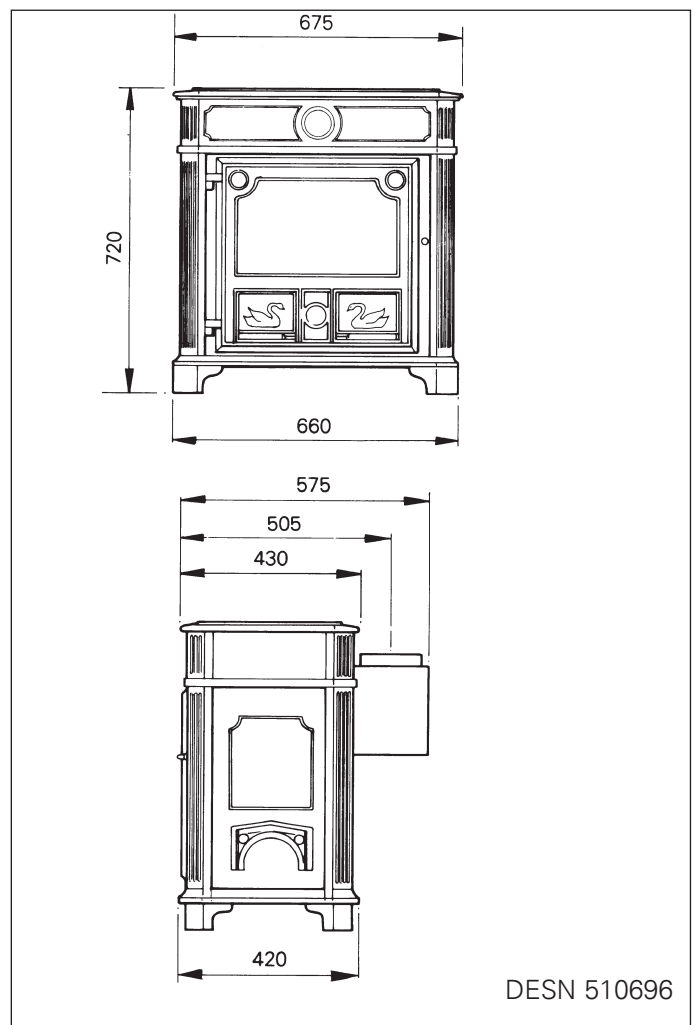

DESN 510696

WP 10/94 EINS 510696

INSTALLATION INSTRUCTIONS

The installation of the appliance must be in accordance with the relevant requirements of the Gas Safety (Installation and Use) Regulations 1994, Building Regulations and the Building Standards (Scotland) (Consolidation) Regulations, issued by the Scottish Development Department. It should be in accordance also with any relevant requirements of the local Gas Region and Local Authority, and the relevant recommendations of the following current British Codes of Practice & British Standards.

BS.6891: Installation of pipes and meters. Low pressure installation pipes.

BS.5440: Part 1 Flues & Part 2 Air Supply

BS.7871: Part 1 Installation of Gas Fires, Convector Heaters, Fire/Back Boilers.

BS.6461: Codes of practice for factory-made insulated chimneys for internal application.

BS8303: Solid fuel appliance flue system.

In your own interest and that of safety to comply with the law all gas appliances should be installed by a competent person (Corgi Registered) in accordance with the above regulations and with these instructions. Failure to install the appliance correctly could lead to prosecution.

THE LOCATION

The stove must not be installed into a non-combustible recess smaller than 845mm wide and 1000mm high.

To ensure adequate circulation of convected air it is recommended that the stove should not be installed into a recess of a depth any greater than 300mm.

The appliance must be installed on a base of incombustible material, at least 12mm thick, extending to at least the front of the stove supporting legs, and to 85mm beyond each side of the stove (845mm). No clearance is required in front of the hearth.

The stove must be installed with a hearth, capable of withstanding a maximum temperature of 150°C. Conglomerate marble, marble and tiled surrounds can meet this requirement.

An area of 1000mm high by 845mm wide behind the appliance must be of a solid non-combustible material (See fig. 1).

Clearance of Shelves: A wooden shelf may be fitted above the stove. The underside of the combustion shelf above the top of the stove should be dimensioned accordingly.

Depth of Shelf	Height to underside of shelf Y
150mm	400mm
175mm	425mm
200mm	450mm
225mm	500mm
250mm	550mm
275mm	600mm
300mm	650mm

NOTE: FOR MINIMUM DIMENSIONS OF RECESS THE SHELF SHOULD BE NON-COMBUSTIBLE.

NOTE: IF THE FLUE PIPE PASSES THROUGH THE SHELF REFER TO SECTION 'SHIELDING OF FLUE PIPES'.

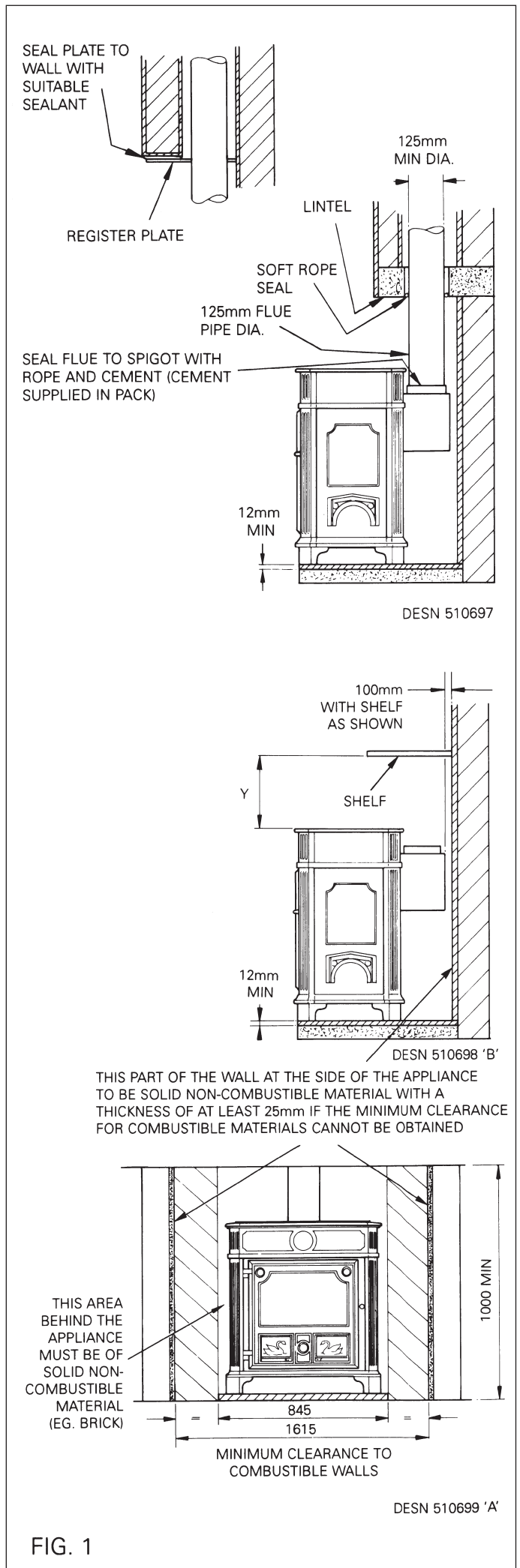

FIG. 1

THE FLUE - See fig 1

The may be used/connected to a solid fuel appliance flue system having a diameter not less than 125mm.

Alternatively, detailed recommendations for gas fluing are given in current issue BS 5258: Part 1.

The following notes are intended to give general guidance:

The cross sectional area of the flue serving the stove must not be less than the area of the flue outlet of the stove and be of at least 3m effective high from the floor level. If flue pipe is to be used, it must not be less than 125mm internal diameter.

Flue Pipes

Flue pipes and fittings should be constructed from one of the following materials.

- a) Cement to BS. 567
- b) Aluminium or stainless steel to BS.715
- c) Cast iron or mild steel to BS. 41 acid resistant vitreous enamelled lined.

If a chimney is to be used, it **MUST** be one that is composed of or lined with a non-porous acid resistant material. (Chimneys lined with salt glazed earthenware pipe are acceptable, if the pipes comply with current issue of BS.65).

Shielding of Flue Pipes

Flue pipe should:

- (a) be at least 25mm from any combustible material, or
- (b) where passing through a wall, floor or roof, be separated from any combustible material by a non-combustible sleeve enclosing an air space of at least 25mm around the flue pipe, or
- (c) where passing through a compartment wall or a compartment floor, be cased with a non-combustible with at least half the fire resistance needed for the wall or floor (see Approved Document B3 Internal Fire Spread).

For a double-walled flue pipe, the 25mm distance may be measured from the outside of the inner pipe.

Factory-Made Insulated Chimneys

Factory-made insulated chimneys should be:

(a) constructed and tested to meet the relevant recommendations given in BS4543. Factory-made insulated chimneys, Part 1. Methods of test for factory-made insulated chimneys and Part 2: Specification for chimneys for solid fuel fired appliances, and

(b) installed in accordance with the manufacturers instructions or to meet the relevant recommendations of BS 6461: Installation of chimneys and flue for domestic appliances burning solid fuel (including wood and peat) and BS 7566 Parts 1 to 4 Installation of factory-made chimneys to BS. 4543 for domestic appliances.

A flue pipe constructed to one of the standards in (a) to (c) should form the connection from the stove to lined chimneys.

If a brick chimney is to be used it **MUST** be swept prior to installation.

Before installing the stove, or inserting a liner, check that the flue is sound, free from obstruction and clean. If a register plate, restrictive plate or damper is fitted in the flue. It **MUST** be removed or locked fully open.

The flue should terminate in accordance with the relevant recommendations given in BS.5440: PART 1.

the point of termination must not be within 600mm of an openable window, air vent or any other ventilation opening.

Check that chimney serves only one appliance, and that the flue and associated connection joints are properly sealed.

AIR SUPPLY

The room containing the appliance must have a permanent air vent or effective area of at least 22cm². The vent must be to outside air or to an adjacent room having a permanent vent to outside air of the same area.

EFFECT OF EXTRACTOR FAN

If there is any type of extractor fan fitted in the same room as the stove, there is a possibility that if adequate air inlet area from outside is not provided, spillage of the products from the appliance flue could occur when the extractor fan is in operation. Where such installations occur, a spillage test as detailed in BS.5440: Part 1 must be carried out.

GAS CONNECTION

The complete installation must be tested for soundness and purged as described in BS.6891.

The gas inlet to the stove is 8mm dia compression, and providing the distance from the service cock to the stove does not exceed 1.5m, 8mm dia rigid or semi-rigid supply pipe may be used.

Above this length, 15mm dia rigid or semi-rigid pipe should be used.

A service cock **must** be fitted adjacent to this appliance.

APPLIANCE ASSEMBLY

Unpacking

Remove all parts from inside the pack and ensure that no damage has occurred during delivery transit. If so, please contact your local stockist.

Items in pack:-

Instructions - Installation/Service and Operating
Blanking Plate (Rear)
Blanking Plate (LHS)
Blanking Plate (RHS)
Turbulators (4)
Coals (18)
Door Locking Tool
Clay Aggregate
Cement (For sealing flue spigot)
Draught Diverter
Throat Restrictor

Fit Draught Diverter

Secure draught diverter with nuts and washers provided (Fig. 2).

IMPORTANT: Ensure sealing rope (factory fitted) is in position before locating draught diverter.

Fit Throat Restrictor

Secure throat plate with bolts, nuts and washers provided (Fig. 3).

INSTALLING THE APPLIANCE

Position the appliance in accordance with the instruction given in the section 'LOCATION' and connect the flue pipe in accordance with the section 'THE FLUE'.

FLEXIBLE PIPE/CONNECTIONS MUST NOT BE USED.

Connect the stove to the gas supply (See Gas Connection).

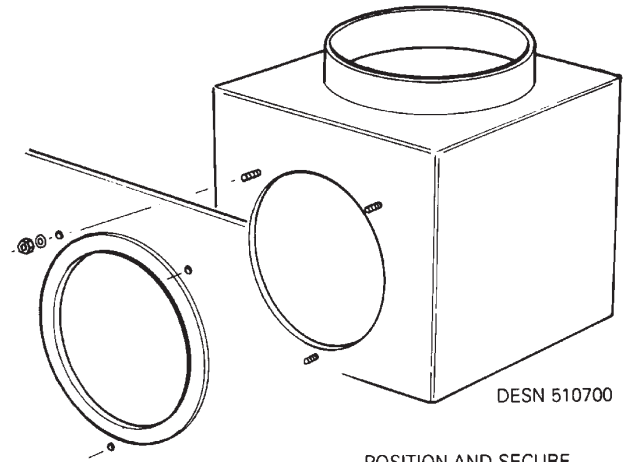

POSITION AND SECURE
DRAUGHT DIVERTER
TO REAR OF STOVE
WITH NUTS AND
WASHERS PROVIDED

FIG. 2

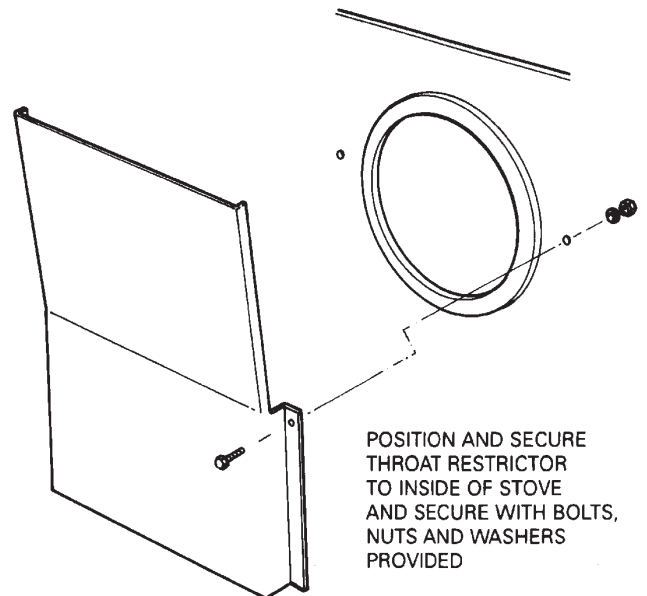

POSITION AND SECURE
THROAT RESTRICTOR
TO INSIDE OF STOVE
AND SECURE WITH BOLTS,
NUTS AND WASHERS
PROVIDED

FIG. 3

DESN 510701

LAYING THE FUEL BED

Open the door of the stove (using the tool supplied). See Fig. 4.

Position the blanking plate as illustrated in fig. 5 and fit the ceramic turbulator over the aeration tubes (fig. 6).

Pour the aggregate into the burner tray as illustrated in fig. 6.

Do not compress or 'tap down'. Any excess should be kept and handed to the User for future use.

Positioning the Coals

Carefully place the coals on the fuel bed as illustrated in figs, 7, 8, 9 and 10.

Close the door and lock (using the tool supplied).

WARNING: USE ONLY THE SIMULATED COALS SUPPLIED WITH THE APPLIANCE TO BUILD THE BED, UNDER NO CIRCUMSTANCES USE EXTRA COALS OR PUT ANY OTHER MATERIAL ON THE FUEL BED.

DO NOT OPERATE THE STOVE WITH THE DOOR OPEN OR IF ANY OF THE GLASS PANELS IN THE DOOR OR SIDES ARE CRACKED OR BROKEN.

Hands should be washed after handling the coals (if gloves are not used).

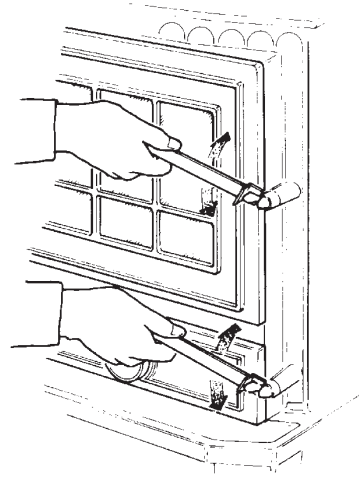

FIG. 4

DESN 510925

LAYING THE FUEL BED

LOCATE THE REAR BLANKING PLATE AS SHOWN.

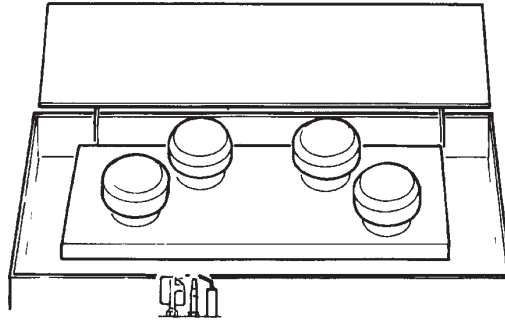

FIG. 5

DESN 510926

LOCATE THE TURBULATORS AS SHOWN.
POUR THE CLAY AGGREGATE SUPPLIED INTO THE TRAY UNTIL IT IS FLUSH WITH THE TOP OF THE BURNER TRAY.

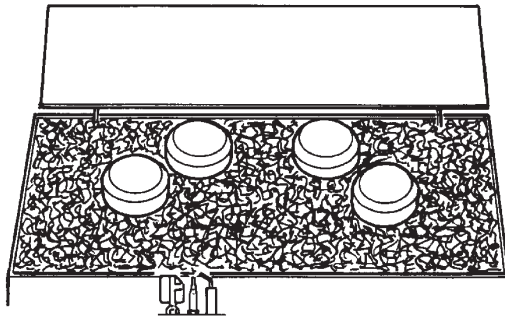
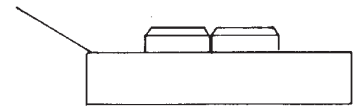

FIG. 6



DESN 510927

LOCATE 4 COALS ON TOP OF THE TURBULATORS AS SHOWN.

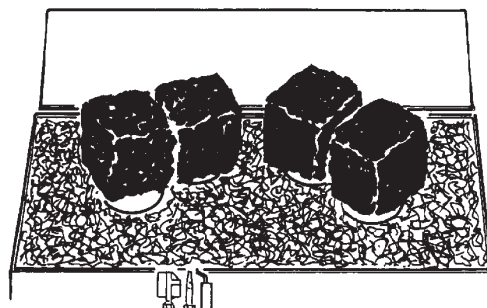

FIG. 7



DESN 510928

PLACE 3 COALS TO THE REAR OF THE BURNER TRAY AS SHOWN.

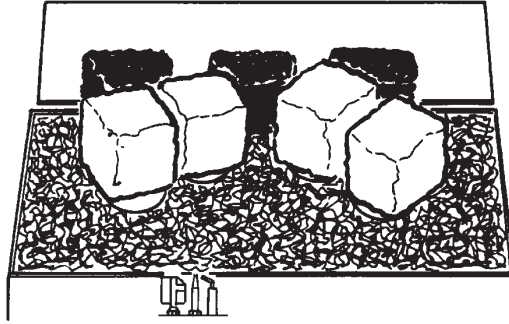

FIG. 8



DESN 510929

PLACE 4 COALS ONTO THE BURNER TRAY AS SHOWN.

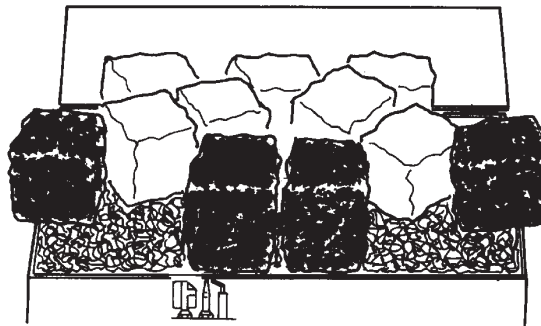

FIG. 9



DESN 510930 'A'

PLACE THE REMAINING 4 COALS ONTO THE BURNER TRAY AS SHOWN.

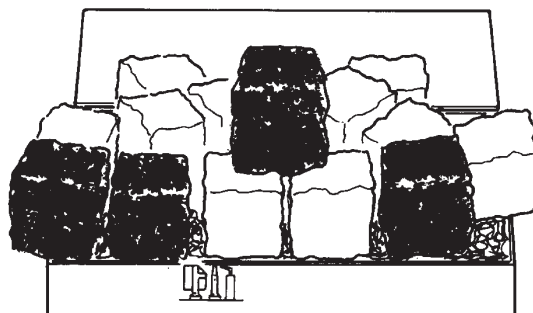
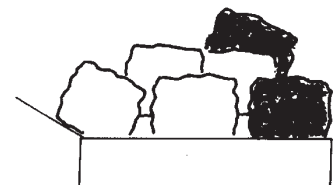

FIG. 10



DESN 510931 'A'

COMMISSIONING AND TESTING

NO SMOKING OR NAKED LIGHTS

Turn on the Gas Supply at the service cock.

The whole installation must be inspected and tested for soundness, and purged up to the gas service cock in accordance with BS. 689.

Remove the pressure test point sealing screw on the burner feed pipe, located at the left hand side of the control valve, connect a suitable pressure gauge. (See Fig. 11).

The control tap is marked with the following positions:-

OFF	●
PILOT	★
MINIMUM	🔥
MAXIMUM	🔥

The stove is fitted with a piezo spark ignitor.

Note: If the main burner or pilot are extinguished for any reason do not attempt to re-light the pilot for three minutes.

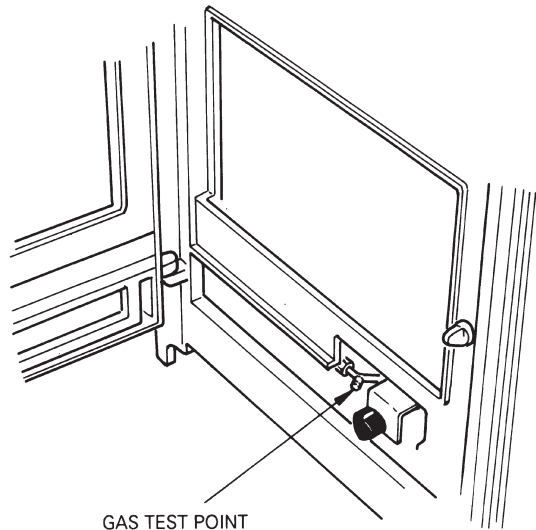

FIG. 11

DESN 510709

TO LIGHT THE PILOT

Open the control access door. Ensure that the glass door is closed and that the control knob is in the OFF (●) position (Fig. 12).

Fully depress the control knob and turn anti-clockwise (keeping the control knob fully depressed) until the pilot position (★) is reached (Fig. 13). If the pilot has not lit repeat the operation.

Once the pilot is lit continue to hold in the control knob for a further 10 - 15 seconds to establish the pilot. When the control knob is released the pilot should remain alight. If the pilot fails to remain alight refer to fault finding section of this document.

If required the pilot may be lit by a long spill or taper as follows:

Open the door of the stove (using the tool supplied). (see Fig. 4).

Apply a lighted long spill or taper to the pilot (See Fig. 14) positioned at the front L.H. side of the burner tray.

Fully depress the control knob anti-clockwise (keeping the control knob fully depressed) until the pilot position (★) has been reached and the pilot should light.

Once the pilot is lit remove the long spill or taper, continue to hold the control knob for 10 to 15 seconds to establish the pilot. When the knob is released, the pilot should remain alight. If the pilot fails to remain alight repeat the procedure, but hold the knob in longer.

When the pilot is established close the door (using the tool supplied).

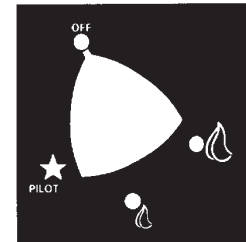

FIG. 12

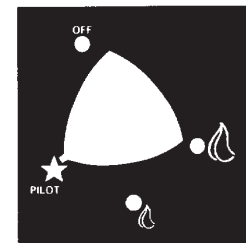

FIG. 13

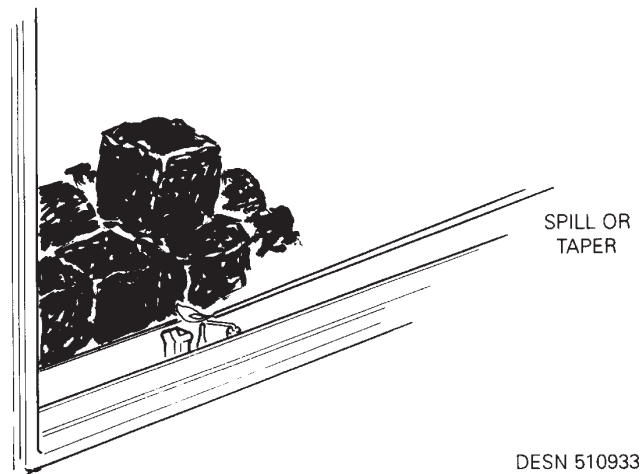

FIG. 14

DESN 510933

TO LIGHT THE STOVE

If the pilot is not already alight, follow procedure to light pilot.

Turn the control knob anti-clockwise to the full on position (🔥) (See Fig. 15). The main burner will light. At this setting the pressure should be 14.2+/-0.75mbar with an inlet pressure of 20mbar.

Depress and turn the control knob clockwise to the pilot position (★) (See Fig. 16). The stove will go out and the pilot will remain alight. Remove the pressure gauge and replace the test point sealing screw.

Turn stove to maximum setting (🔥) (Fig. 17) and check for gas soundness.

FIG. 15

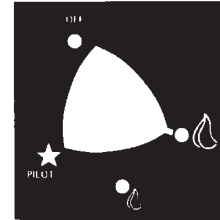

FIG. 16

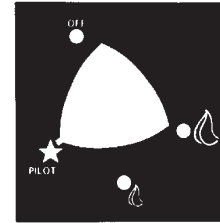
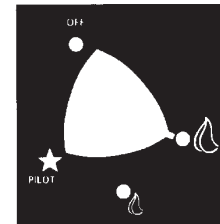

FIG. 17



TO TURN STOVE OFF

Turn the gas control knob to the minimum gas rate position (🔥) (Fig. 18), slightly depress the knob and continue turning to the pilot position (★) (Fig. 19). The fire will go out, and the pilot will remain lit and may be left on permanently.

FIG. 18

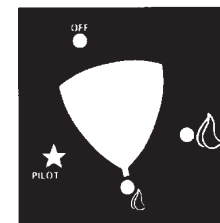
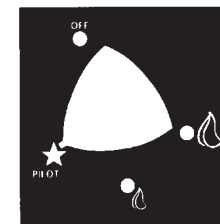

FIG. 19



TO TURN STOVE AND PILOT OFF

Turn the stove off as described. Depress the control knob, turn to the off position (●) (Fig. 20) and the pilot will go out.

FIG. 20

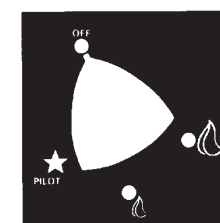

CHECK FOR CLEARANCE OF PRODUCTS OF COMBUSTION

Ensure that all doors and windows of the room are closed.

Light the stove as described. Leave on maximum rate for 5 minutes.

If there is a fan in a nearby room then the spillage test must be repeated with the fan turned on and any interconnecting doors between the stove and the fan location left open.

A spillage test as detailed in BS.5440 must be carried out after 5 minutes as follows - By holding a smoke match so that match head is approximately 3mm up inside the lower edge of the draught diverter (see Fig. 21). Spillage is indicated by smoke being displaced outwards from the draught diverter. If in doubt repeat after a further 10 minutes.

If spillage is detected the chimney may be faulty. The fault must be corrected before leaving the stove installed,

If the fault cannot be corrected turn off and disconnect the gas supply to the stove and seek expert advice.

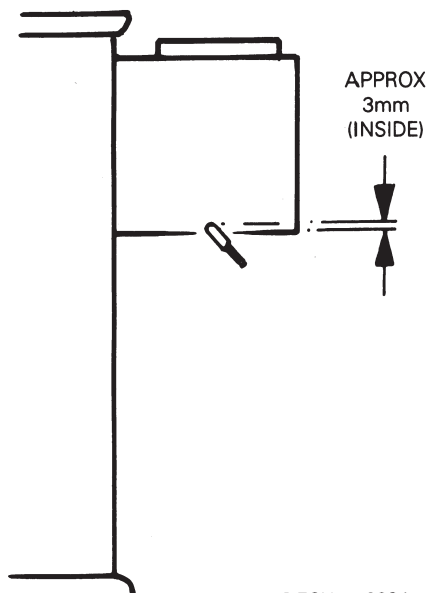

FIG. 21

DESN 510294

INSTRUCT USER

Hand over all the instructions to the user and explain how to light and operate the appliance.

Impress upon the user that coals must be located in accordance with the instructions and that the appliance **MUST NOT** be operated with the glass panel in the door cracked or broken. The appliance should be serviced at regular intervals by a competent person to ensure safe operation.

Point out the removable warning labels which the customer **MUST** remove and read.

Advise the user that any smell emitted from the stove on initial lighting will quickly clear away with use.

The door tool **MUST** be stored in a safe place out of the reach of children

SERVICING AND REPLACEMENT PARTS

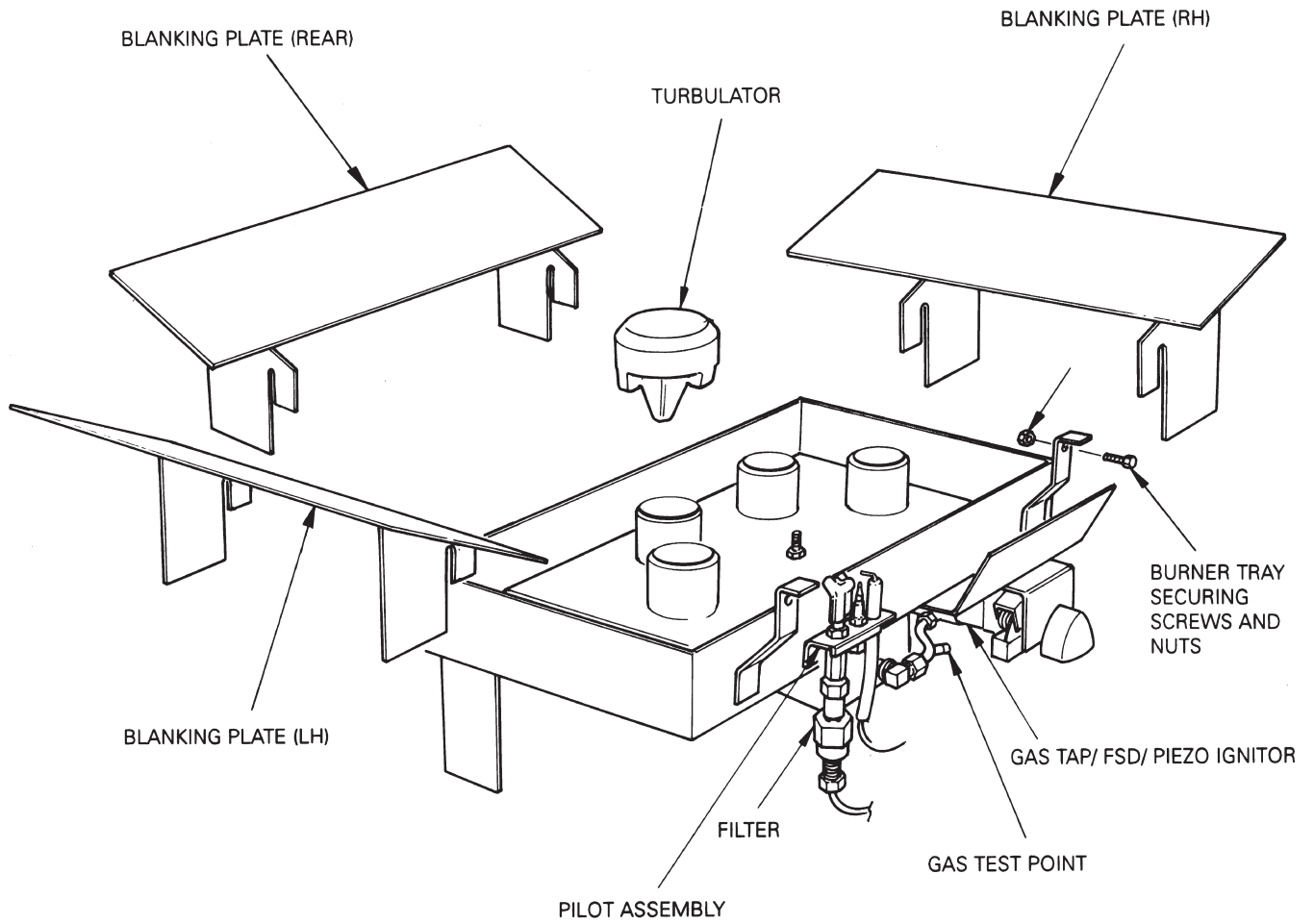

DESN 510711

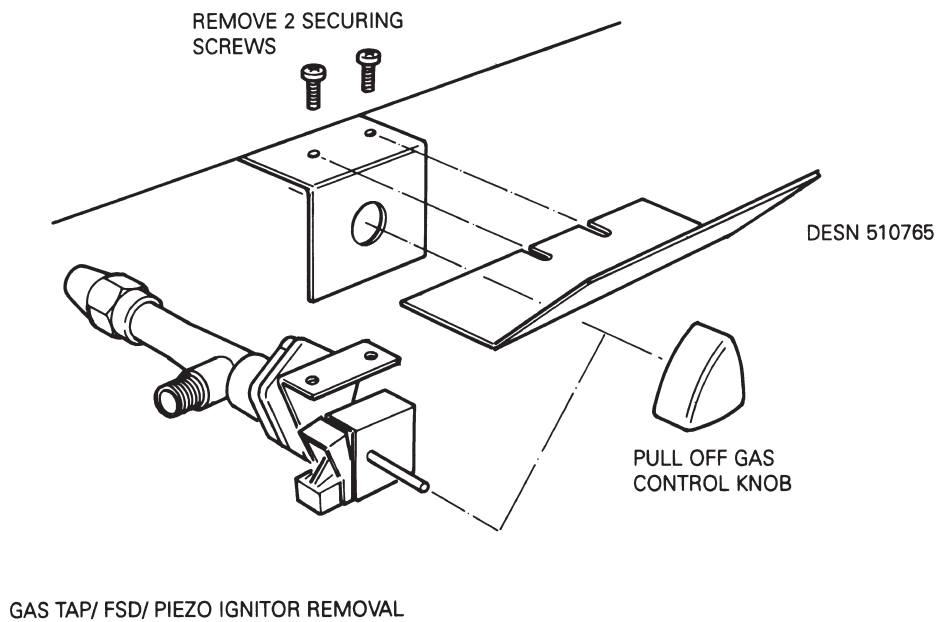

FIG. 22

SERVICING

It is recommended that the stove is inspected/serviced annually by a competent person (e.g. A Corgi Registered Installer).

It is recommended that the flue is checked for debris.

After any servicing **ALWAYS** check for gas soundness, and carry out a spillage test as detailed in the section 'CHECK FOR CLEARANCE OF PRODUCTS OF COMBUSTION'.

RE-ASSEMBLE PARTS IN REVERSE ORDER.

SERVICING PROCEDURE

Ensure that the stove is cold.

Isolate the gas supply to the stove.

Hands should be washed after handling coals (If gloves are not used).

Open the door of the stove (using the tool supplied).

Carefully remove all coals from the fire and inspect for Damage/Breakage. Clean any excessive soot from the coals with a soft brush.

A VACUUM CLEANER MUST NOT BE USED, as this could remove the clay aggregate.

IMPORTANT: Carefully replace the coals as described in the section 'LAYING THE FUEL BED'.

REPLACEMENT OF PARTS

Ensure the stove is cold.

Isolate the gas supply to the stove.

On completion ALWAYS check for gas soundness.

Hands should be washed after handling coals (if gloves are not used).

Open the door of the stove (Using the tool supplied).

Disconnect gas supply to Control Valve.

Remove coals, turbulators and blanking plate (See Fig. 22).

Remove the Burner Assembly, Tray Location and Securing Screws and nuts (See Fig. 22).

Carefully lift out the burner assembly tray and retain the clay aggregate. If necessary top up the tray with clay aggregate during re-assembly as described in 'LAYING THE FUEL BED'.

The following components can now be replaced as follows:

Gas Tap/FSD/Piezo Ignitor

Note: The Piezo Ignitor is an integral part of the above item and is not available as a separate item.

Disconnect the thermocouple, the injector and pilot feed pipes at the Gas Tap/FSD/Piezo Ignitor.

Disconnect the ignition lead at the tap.

Pull off the control knob and remove the Gas Tap/FSD/Piezo Ignitor (2 screws). (See Fig. 22).

Fit replacement Gas Tap/FSD/Piezo Ignitor and re-assemble in reverse order, carefully replace the coals as described in 'LAYING THE FUEL BED'.

CHECK THE BURNER PRESSURE AS DESCRIBED IN 'TO LIGHT THE STOVE'.

Main Burner Injector

Disconnect feed pipe at the main injector and Gas Tap/FSD/Piezo Ignitor as detailed above. Remove injector.

Fit replacement injector and re-assemble in reverse order, carefully replace the coals as described in 'LAYING THE FUEL BED'.

Pilot Assembly

Disconnect the feed pipe at the pilot assembly.

Disconnect the thermocouple connection at the control valve and pull off the ignition lead from the electrode.

Remove pilot filter.

Remove pilot assembly (one nut).

Fit replacement pilot assembly, and re-assemble in reverse order.

NOTE: Ensure that the insulation sleeving is pushed back over the end of the electrode during re-assembly.

Carefully replace the coals as described in 'LAYING THE FUEL BED'.

FAULT FINDING CHART

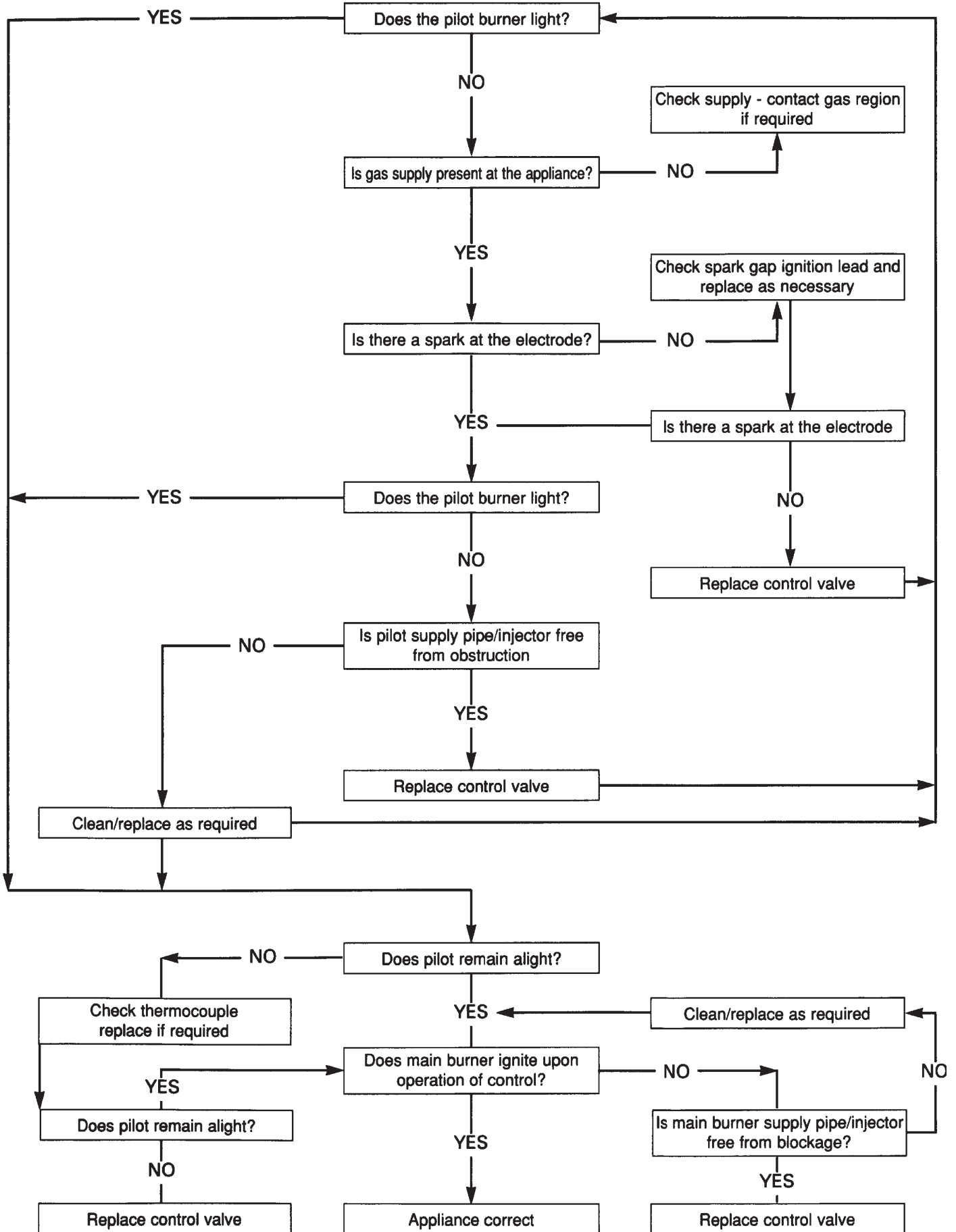

SPARE PARTS

COALS PACK CONTAINING:-

BLACK, 9 SMALL



BLACK, 14 LARGE

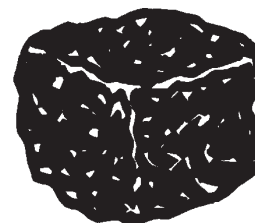

DESN 510888

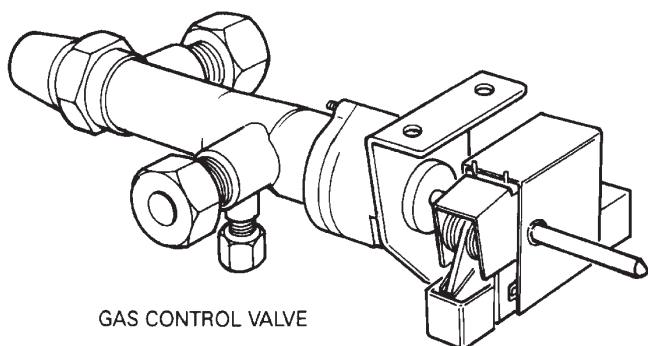

GAS CONTROL VALVE



CONTROL KNOB

DESN 510726

PILOT ASSEMBLY

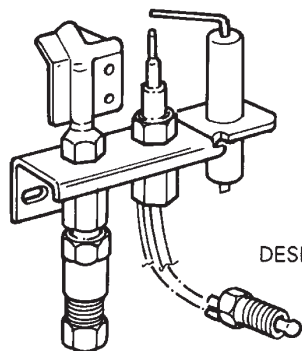

DESN 510623

BURNER INJECTOR

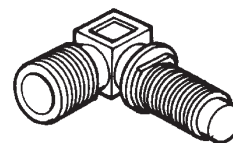

DESN 510727

SHORT LIST OF SPARE PARTS

The following Spare Parts are available from your Distributor:

DESCRIPTION	MAKERS PART NUMBER
1. Gas Tap/FSD/Piezo Ignitor - NG	HG4M 414045
2. Pilot Assembly - NG	FG4M 420330
3. Burner Injector - NG	FG4M 420381
4. Control Knob	HG4M 999413
5. Coals Pack	FG4M 420661
6. Aggregate Pack	TCLY 414047
7. Turbulator	FG4M 420450
8. Door Tool	HS1M 93003

THEY SHOULD BE FITTED ONLY BY A COMPETENT PERSON (e.g. A CORGI Registered Installer).

SPARE PARTS

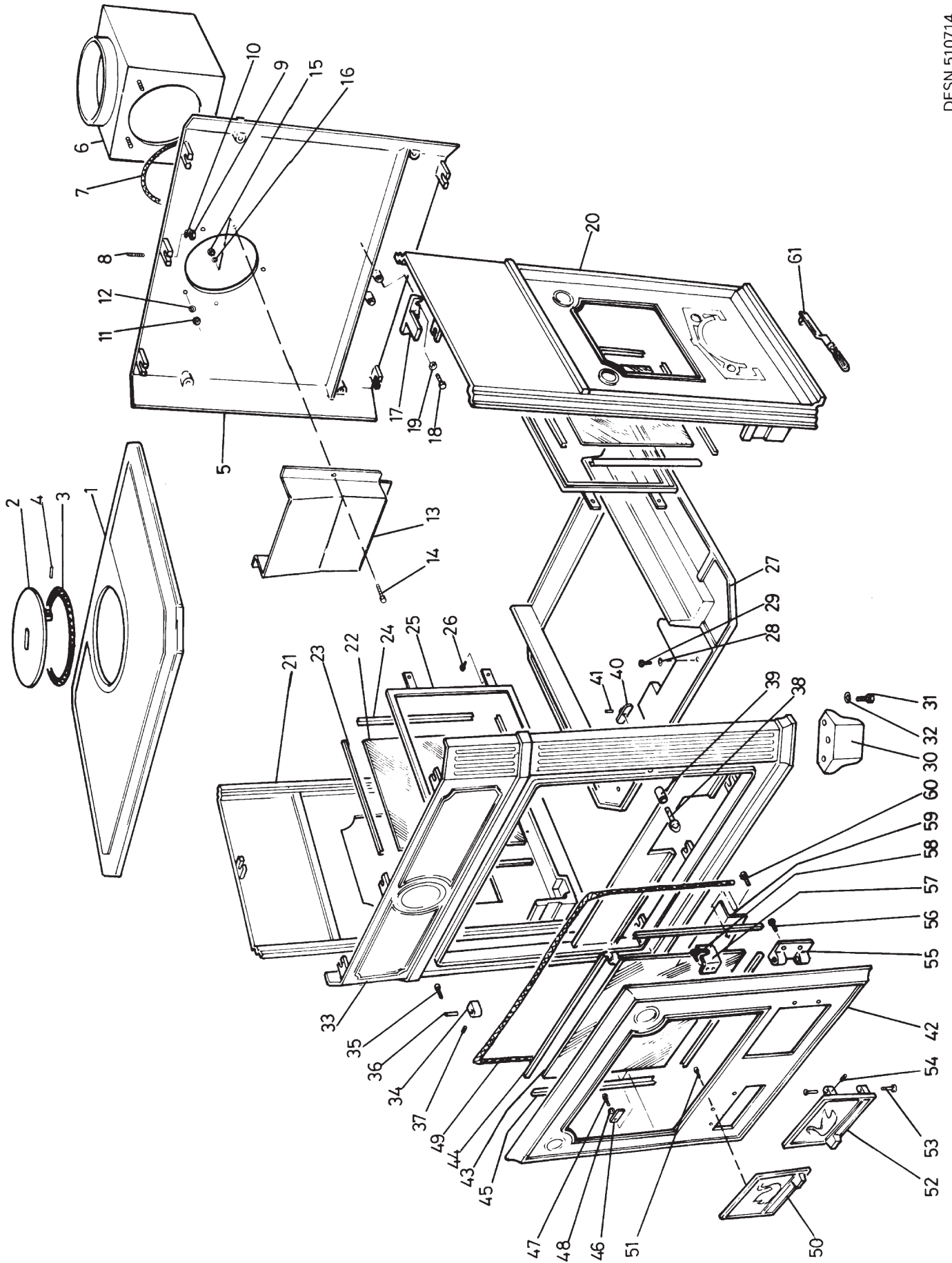

DESN 510714

SPARE PARTS

ITEM	DESCRIPTION	ITEM	DESCRIPTION
1	TOP PLATE	33	FRONT PLATE
2	FLUE OUTLET BLANKING PLATE	34	HINGE BLOCK
3	ROPE 8 DIA x 550mm LG	35	SCREW M8 x 20mm LG HEX HD
4	BISSEL PIN 6mm DIA x 20mm LG	36	DOOR HINGE PIN
5	BACKPLATE	37	SCREW M6 x 10 LG SKT GRUB SCREW
6	FLUE DIVERTER ASSEMBLY	38	FIREDOOR CATCH SHAFT
7	ROPE 13 DIA x 550 LG	39	FIREDOOR CATCH SHAFT
8	ALLTHREAD M6 x 330mm LG	40	FIREDOOR CATCH
9	NUT M6 HEX FULL	41	SPIROL PIN 3/16" DIA 3/4" LG
10	WASHER M6 PLAIN	42	FIREDOOR
11	NUT M6 HEX FULL	43	FIREDOOR GLASS
12	WASHER M6 PLAIN	44	FIREDOOR GLASS SEALING CHANNEL - HORIZONTAL
13	THROAT PLATE	45	FIREDOOR GLASS SEALING CHANNEL - VERTICAL
14	SCREW M6 x 40 LG HEX ST/STL	46	RETAINING CLIP
15	NUT M6 FULL ST/STL	47	SCREW M5 x 12 LG HEX HD
16	WASHER M6 SHAKEPROOG (EXT)	48	WASHER M5 PLAIN
17	CENTRE SUPPORT	49	FIREDOOR ROPE 9 DIA x 1140mm LG
18	SCREW M6 x 16 MM HEX HD	50	COOVER PLATE (LH SWAN)
19	WASHER M6 PLAIN	51	SCREW M5 x 10mm LG POZI PAN HD
20	RH SIDEPLATE	52	CONTROLS COVER PLATE (RH SWAN)
21	LH SIDEPLATE	53	CONTROLS COVER HINGE PIN
22	SIDEPLATE GLASS	54	SCREW M3 x 5mmSKT GRUB SCREW
23	SIDEPLATE GLASS SEALING CHANNEL - HORIZONTAL	55	HINGE
24	SIDEPLATE GLASS SEALING CHANNEL - VERTICAL	56	SCREW M5 x 12 LG HEX HD
25	GLASS RETAINING FRAME ASSEMBLY	57	FIREDOOR CATCH
26	SCREW M5 x 10mm LG POZI PAN HD	58	SCREW M5 x 12 LG HEX HD
27	BASEPLATE	59	COALGUARD
28	SCREW M6 x 20mm LG HEX HD	60	SCREW M5 x 12 HEX HD
29	WASHER M6 PLAIN	61	OPERATING TOOL
30	SUPPORT LEG		
31	SCREW M8 x 20 LG HEX HD		
32	WASHER M8 PLAIN		

SPARE PARTS

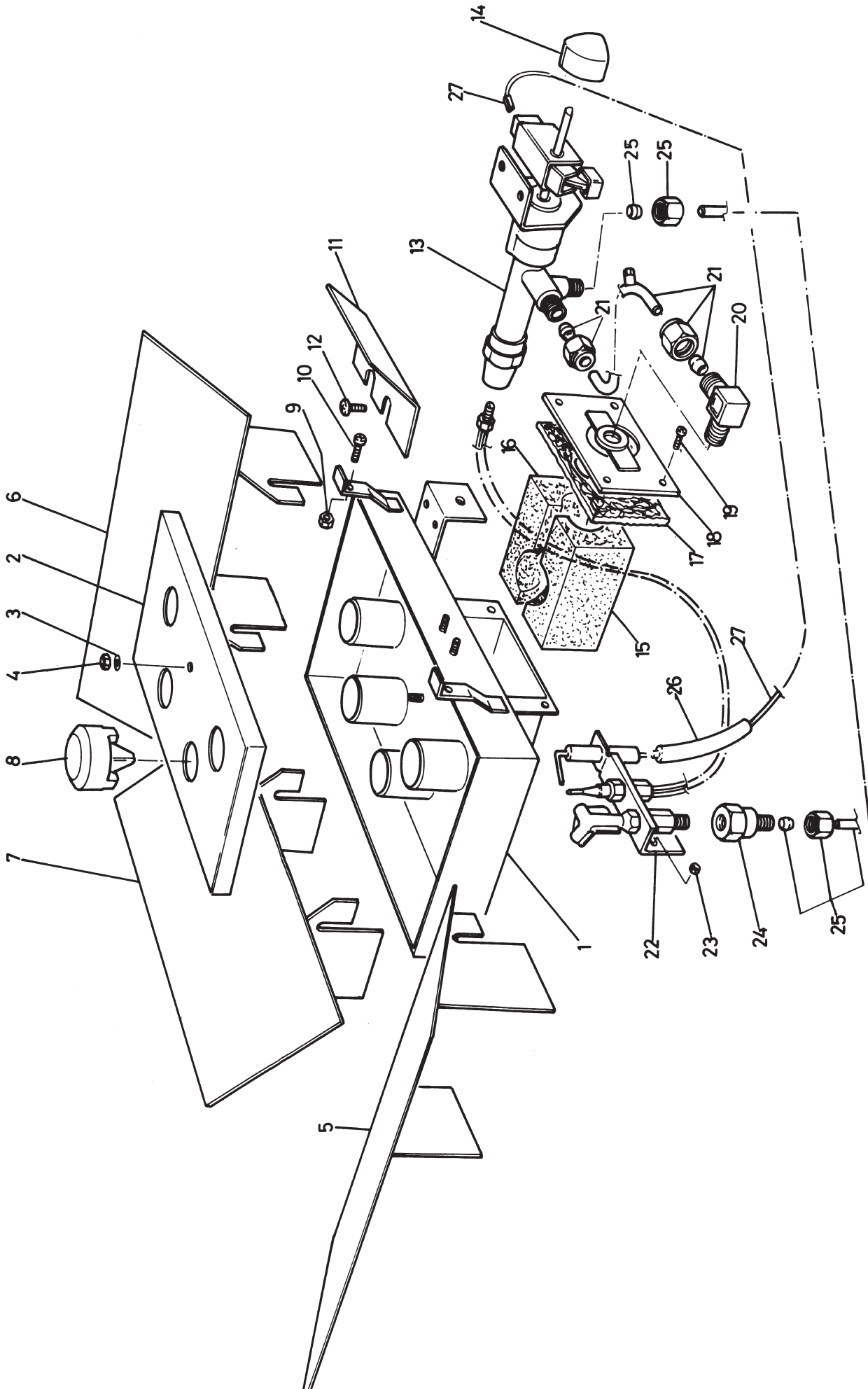

DESN 510715

SPARE PARTS

ITEM	DESCRIPTION	
1	BURNER TRAY ASSEMBLY - NATURAL GAS	
2	SPREADER PLATE - NATURAL GAS	
3	WASHER M6	
4	NUT FULL M6	
5	BLANKING PLATE ASSEMBLY - LH	
6	BLANKING PLATE - RH	
7	BLANKING PLATE - REAR	
8	TURBULATOR	
9	NUT - M6 FULL	
10	SCREW M6 x 35mm LG POZI PAN HD	
11	HEAT SHIELD	
12	SCREW M5 x 6mm LG P/PAN HD ST/STEEL	
13	CONTROL VALVE - NG CONCENTRIC - TESA 2301A INCLUDING ITEM 14	
14	CONTROL KNOB	
15	CERAMIC VENTURI - LH	
16	CERAMIC VENTURI - RH	
17	GASKET - INJECTOR MOUNTING PLATE	
18	INJECTOR - MOUNTING PLATE ASSEMBLY - NG	
19	SCREW M4 x 10mm PAN HD - TAPTITE	
20	BURNER INJECTOR - NH 82/900	
21	TEST NIPPLE COMP.	
22	PILOT ASSEMBLY - NG	
23	NUT - M4 HEX	
24	PILOT FILTER	
25	PILOT FEED PIPE COMP	
26	VIDAFLEX SLEEVING 7.00 DIA x 1mm x 60LG	
27	IGNITION LEAD 2.5 SQ 50/0.25 Ni/Cu WIRE PTFE	

With Aga-Rayburn's policy of continuous product improvement, the Company reserves the right to change specifications and make modifications to the appliance described and illustrated at any time.

COALBROOKDALE

Manufactured By
Aga-Rayburn
Station Road, Ketley, Telford, Shropshire, TF1 5AQ

Telephone (01952) 642000 Fax (01952) 641961

**For further advice or information contact
your local distributor/stockist**