

WARNING

This information is a copy of an original archive,
therefore Aga-Rangemaster cannot be held
responsible for its continued accuracy or relevance

THE COALBROOKDALE GS2 Installation and Servicing Instructions for The Coalbrookdale GS2 Gas Fired Stove

Traditional

Top Rear Open Flue Model *ONLY*

Consumer Protection Act 1987

As manufacturers and suppliers of cooking and heating products, in compliance with Section 10 of the Consumer Protection Act 1987, we take every care to ensure, as far as is reasonably practicable, that these products are so designed and constructed as to meet the general safety requirement when properly used and installed. To this end, our products are thoroughly tested and examined before despatch.

IMPORTANT NOTICE: Any alteration that is not approved by Coalbrookdale, could invalidate the approval of the appliance, operation of the warranty and could also affect your statutory rights.

Control of Substances - Health and Safety Important

This appliance may contain some of the materials that are indicated below. It is the Users/Installers responsibility to ensure that the necessary personal protective clothing is worn when

handling, where applicable, the pertinent parts that contain any of the listed materials that could be interpreted as being injurious to health and safety, see below for information.

Firebricks, Fuelbeds, Artificial Fuels - when handling use disposable gloves.

Fire Cement - when handling use disposable gloves.

Glues and Sealants - exercise caution - if these are still in liquid form use face mask and disposable gloves.

Glass Yarn, Mineral Wool, Insulation Pads, Ceramic Fibre, Kerosene Oil - may be harmful if inhaled, may be irritating to skin, eyes, nose and throat. When handling avoid inhaling and contact with skin or eyes. Use disposable gloves, face-masks and eye protection. After handling wash hands and other exposed parts. When disposing of the product, reduce dust with water spray, ensure that parts are securely wrapped.

GAS DATA				
	NG		PROPANE	
MAX	kW	Btu/h	kW	Btu/h
HEAT INPUT	10.3	35000	9.2	31390
HEAT OUTPUT	5.0	17000	4.5	15350
MIN	kW	Btu/h	kW	Btu/h
HEAT INPUT	5.0	17000	4.9	16700
HEAT OUTPUT	2.0	6800	1.9	6500

Burner Injector Nat - Cat 82-900
 Burner Injector Propane - Cat 92-320
 Pilot Injector Nat - No.4
 Pilot Injector Propane - No.28
 Gas Connection 8mm OD Tubing

Flue Spigot Size - 127mm Dia.
 Ignition - Piezo Spark Generator
 Appliance Weight 115kg

SETTING PRESSURE (COLD)							
NATURAL				PROPANE			
MAX		MIN		MAX		MIN	
mbar	in.wg	mbar	in.wg	mbar	in.wg	mbar	in.wg
11.0	4.4	3.0	1.2	36.0	14.4	10.0	4.0

INTRODUCTION

The Coalbrookdale GS2 is factory set to operate on natural gas or propane (See data label).

Due to newness the stove may give off a slight smell for a short period of after commissioning. This is quite normal and will disappear after a few hours operation, open windows and doors if required.

The Coalbrookdale GS2 has two access doors as part of its design. The glass fronted door is for access to the coals and apart from initial commissioning of the stove, or incase the pilot may be lit with a taper due to malfunction of the spark ignition system. **UNDER NO CIRCUMSTANCES MUST THE STOVE BE OPERATED WITH THE DOORS OPEN.**

The Coalbrookdale GS2 has been designed similar to a solid fuel stove to relevant safety standards, but during use many parts of the appliance can become VERY HOT to touch. We recommend that you provide and secure a fireguard complying with BS 6539 when the stove is used by elderly, infirm or young persons.

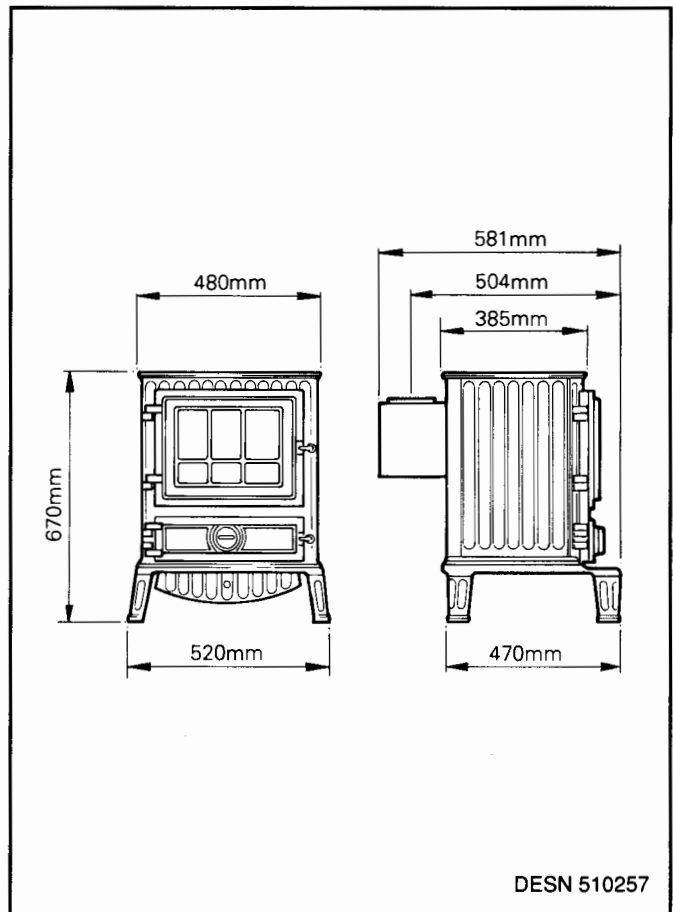

DESN 510257

INSTALLATION INSTRUCTIONS

The installation of the appliance must be in accordance with the relevant requirements of the Gas Safety (Installation and Use) Regulations 1984 (as amended), Building Regulations and the Building Standards (Scotland) (Consolidation) Regulations. It should be in accordance also with any relevant requirements of the local Gas Region and Local Authority, and the relevant recommendations of the following current British Codes of Practice & British Standards:

BS.6891: Installation of pipes and meters. Low pressure installation pipes

BS.5440: Part 1 Flues & Part 2 Air Supply

BS.5871: Part 1 Installation of Gas Fires, Convector Heaters, Fire/Back Boilers.

BS.6461: Codes of Practice for factory-made insulated chimneys for internal application.

BS8303: Solid fuel appliance flue system.

In your own interests and that of safety to comply with the law all gas appliances should be installed by a competent person, (Corgi Registered) in accordance with the above regulations and with these instructions. Failure to install the appliance correctly could lead to prosecution.

THE LOCATION

If the stove is installed into a recess of a depth greater than 410mm. The heat output to the room will be reduced.

The appliance must be installed on a base of incombustible material, at least 12mm thick, extending to at least the front of the stove supporting legs or level with the supporting front legs when fitted in their alternative position, and to 85mm beyond each side of the stove (640mm). See fig.1. No clearance is required in front of the hearth.

The stove must be installed with a hearth capable of withstanding a maximum temperature of 150°C. Conglomerate marble, marble and tiled surrounds can meet this requirement.

If the rear wall (behind the appliance) is of combustible material there must be an air gap of at least 75mm or a shield of non-combustible material, at least 25mm thick the width and height of the appliance. See fig.1.

Clearances for Shelves: A wooden shelf may be fitted above the stove. The underside of the combustible shelf above the top of the stove should be dimensioned accordingly.

Depth of shelf	Height to underside of shelf Y.
150mm	558mm
175mm	575mm
200mm	600mm
225mm	650mm
250mm	700mm
275mm	750mm
300mm	800mm

NOTE: IF THE FLUE PIPE PASSES THROUGH THE SHELF REFER TO SECTION 'SHIELDING OF FLUE PIPES'.

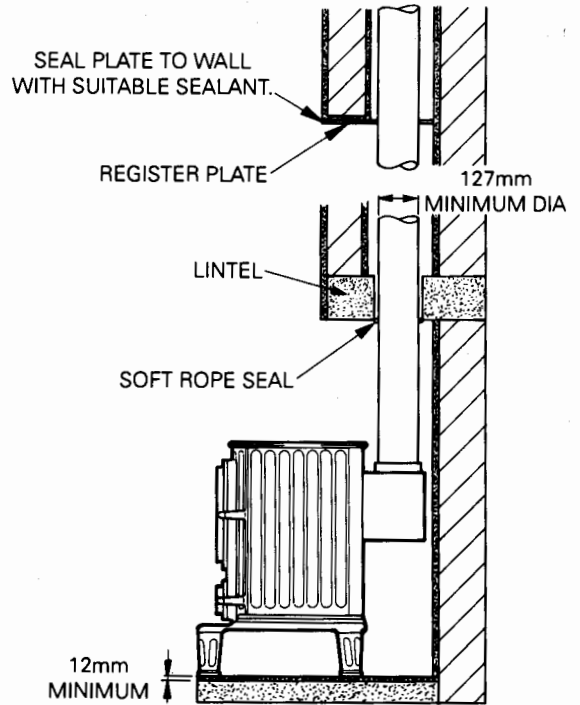

DESN 510258

TO BE MINIMUM OF 75mm IF THE WALL IS MADE OF COMBUSTIBLE MATERIAL

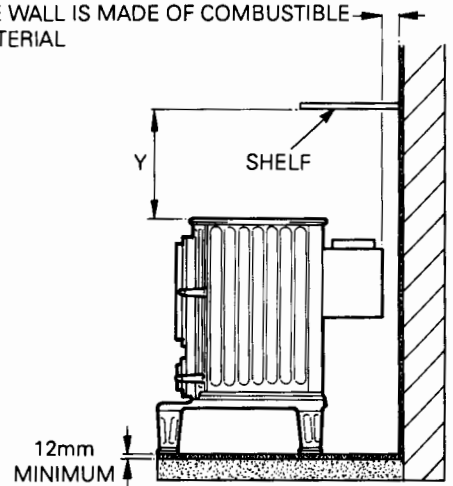

DESN 510259

THIS PART OF THE WALL AT THE BACK AND SIDE OF THE APPLIANCE TO BE SOLID NON-COMBUSTIBLE MATERIAL WITH A THICKNESS OF AT LEAST 25mm IF THE MINIMUM CLEARANCES FOR COMBUSTIBLE MATERIALS CANNOT BE OBTAINED.

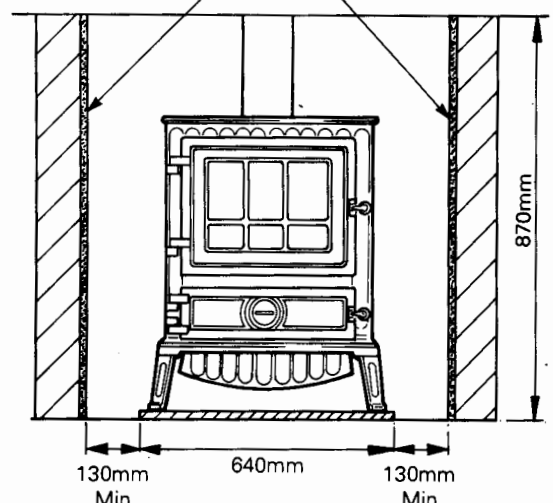

Fig.1 Flue Layouts

DESN 510260

THE FLUE - See fig 1

The appliance may be used/connected to a solid fuel appliance flue system having a diameter not less than 127mm.

Alternately, detailed recommendations for gas fluing are given in current issue BS.5440:Part 1.

The following notes are intended to give general guidance:

The cross sectional area of the flue serving the stove must not be less than the area of the flue outlet of the stove and be of at least 3m effective high from the floor level. If flue pipe is to be used, it must be not less than 127mm internal diameter.

Flue Pipes

Flue pipes and fittings should be constructed from one of the following materials.

- Cement to BS.567
- Aluminium or stainless steel to BS.715
- Cast iron or mild steel to BS.41 acid resistant vitreous enamelled lined.

If a chimney is to be used, it MUST be one that is composed of or lined with a non-porous acid resistant material. (Chimneys lined with salt glazed earthenware pipes are acceptable, if the pipes comply with current issue of BS.65).

Shielding of Flue Pipes

Flue pipes should:

- be at least 25mm from any combustible material, or
- where passing through a wall, floor or roof, be separated from any combustible material by a non-combustible sleeve enclosing an air space of at least 25mm around the flue pipe, or
- where passing through a compartment wall or a compartment floor, be cased with non-combustible material with at least half the fire resistance needed for the wall or floor (see Approved Document B3 Internal fire spread (structure)).

For a double-walled flue pipe, the 25mm distance may be measured from the outside of the inner pipe.

Factory-Made Insulated Chimneys

Factory-made insulated chimneys should be:

(a) constructed and tested to meet the relevant recommendations given in BS4543 Factory-made insulated chimneys, Part 1: Methods of test for factory-made insulated chimneys and Part 2: Specification for chimneys for solid fuel fired appliances, and

(b) installed in accordance with the manufacturers' instructions or to meet the relevant recommendations of BS 6461: Installation of chimneys and flues for domestic appliances burning solid fuel (including wood and peat) and BS 7566 Parts 1 to 4 Installation of factory-made chimneys to BS. 4543 for domestic appliances.

A flue pipe constructed to one of the standards in (a) to (c) above, should form the connection from the stove to lined chimneys.

Before connecting the stove to, or inserting a liner into, a flue that has been previously used for solid fuel, the flue **must be** thoroughly swept clean of any soot and loose material. If a register plate, restrictive plate, damper etc. is fitted in the flue, it must be removed before connecting the stove to, or inserting a liner, into the flue.

The flue should terminate in accordance with the relevant recommendations given BS.5440: PART 1.

The point of termination must not be within 600mm of an openable window, air vent or any other ventilation opening.

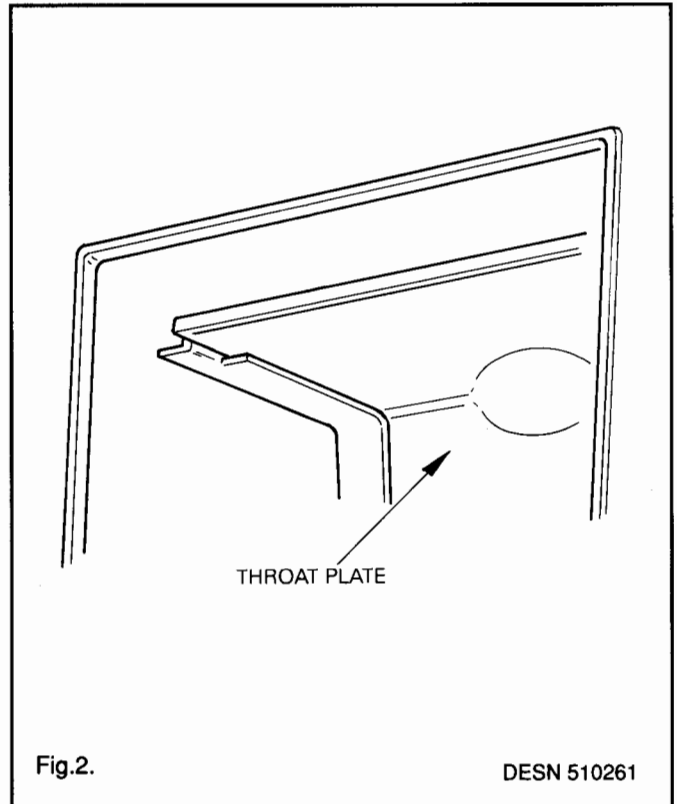

Fig.2.

DESN 510261

Check that chimney serves only one appliance, and that the flue and associated connection joints are properly sealed.

AIR SUPPLY

The room containing the appliance must have a permanent air vent or effective area of at least 15cm². The vent must either be to outside air or to an adjacent room having a permanent vent to outside air of the same area.

EFFECT OF AN EXTRACTOR FAN

If there is any type of extractor fan fitted in the same room as the stove, there is a possibility that if adequate air inlet area from outside is not provided, spillage of the products from the appliance flue could occur when the extractor fan is in operation. Where such installations occur, a spillage test as detailed in BS:5440: Part 1 must be carried out.

GAS CONNECTION

The complete installation must be tested for soundness and purged as described in BS6891.

The gas inlet to the stove is 8mm dia compression, and providing the distance from the service cock to the stove does not exceed 1.5m, 8mm dia supply pipe may be used.

Above this length, 15mm dia pipe should be used. A service cock **must** be fitted adjacent to this appliance.

APPLIANCE ASSEMBLY

Unpacking

Remove all packaged parts from inside the stove and ensure that no damage has occurred during delivery transit. If so, please contact your local stockist.

Items in pack:

Instructions - Installation/Service and Operating
Throat Plate
Burner Rear Spacer Plate
Small Coals Pack (25 coals)
Large Coals Pack (45 coals)
Finger Coals Pack (5 coals)
Control Cover
Door Locking Tool
Vermiculite
Ceramic Turbulators

Proceed to assemble the stove as follows:

Ensure the throat plate is correctly located inside the appliance and is supported on the 2 throat restrictor supports. See Fig .2.

INSTALLING THE APPLIANCE

Position the appliance in accordance with the instruction given in the section 'LOCATION' and connect the flue pipe in accordance with the section 'THE FLUE'.

FLEXIBLE PIPE/CONNECTIONS MUST NOT BE USED.

Connect the stove to the gas supply. (See Gas Connection)

LAYING THE FUEL BED

Open the door of the stove. (Using the tool supplied).

Fit the ceramic turbulators over aeration tubes (see fig.3).

Ensure Burner Rear Spacer Plate is correctly located (See Fig.3).

Pour the vermiculite material supplied into the tray until it is flush with the top of the stove tray and make level by using the burner tray assembly sides as a guide.

Do not compress or 'tap down' .. Any excess should be kept and handed to the User for future use.

Small Coals

IT IS IMPORTANT THAT THESE COALS ARE POSITIONED AS ACCURATELY AS POSSIBLE, AS THEY SUPPORT THE SECOND LAYER OF LARGE COALS AND, IF THEY ARE PLACED TOO CLOSE TOGETHER IT WILL AFFECT THE FLAME PICTURE.

Place the 25 small coals on the vermiculite bed as shown in fig 4 leaving a gap of at least 12mm between each of the coals.

Large Coals

IT IS IMPORTANT THAT WHEN THE LARGE COALS ARE PLACED THAT EACH COAL IS STABLE AND IS NOT LIKELY TO ROLL, OR FALL OUT OF ITS POSITION.

Place a large coal on top of each turbulator (See Fig.5).

Place a layer of 14 coals on top of the small coals, keeping the coals reasonably open (see fig.6).

Place 10 large coals to the rear of the stove (see fig.7).

Place the remaining 17 large coals on top of the large coals on the fuelbed, excluding the 5 across the front (see fig.8).

Place the 5 finger coals on top of the coals at the rear of the stove to break up the regular appearance of the coal bed (See Fig. 9).

Close the door and lock (using the tool supplied).

WARNING: USE ONLY THE SIMULATED COALS SUPPLIED WITH THE APPLIANCE TO BUILD THE BED. UNDER NO CIRCUMSTANCES USE EXTRA COALS OR PUT ANY OTHER MATERIAL ON TO THE FIRE BED.

DO NOT OPERATE THE STOVE WITH THE DOORS OPEN.

Hands should be washed after handling coals.

COMMISSIONING AND TESTING

NO SMOKING OR NAKED LIGHTS.

The whole installation, must be inspected and tested for soundness, and purged up to the gas service cock in accordance with recommendations of BS 6891.

Remove the pressure test point sealing screw on the burner feed pipe at the left side of the control valve and connect a suitable pressure gauge. (See fig.9)

The lighting instructions are marked with positions for OFF (•) PILOT (*) and a graduated section for MIN to MAX gas rate. (See fig.10)

The stove is fitted with a piezo spark ignitor.

Note: If the main burner or pilot are extinguished for any reason do not attempt to relight the pilot for three minutes.

TO LIGHT THE PILOT

Ensure that the control knob is in the OFF position.

Fully depress the control knob and turn anticlockwise (keeping the control knob fully depressed) until the spark position has been reached. If the pilot has not lit repeat the operation.

Once the pilot is lit continue to hold in the control knob for a further 10 - 15 seconds to establish the pilot. When the control knob is released the pilot should remain alight. If the pilot fails to remain alight refer to fault finding section of this document.

TO LIGHT THE STOVE

If the pilot is not already alight, light the pilot as described.

Remove the gas valve control cover and plastic gas valve cover. (See Fig.9).

Remove flow rate adjustment cover securing screw, remove cover to reveal flow rate adjustment screws.

Turn the control knob anticlockwise until the maximum flame position is reached. The main burner flame will ignite. Check the setting pressure at maximum rate. The pressure should be (11.0mbar Nat) or (36.0 mbar Propane). If necessary adjust the maximum flow rate by turning the maximum flow adjusting screw clockwise (with a small screwdriver) to reduce the flow or anticlockwise to increase the flow. (See fig.11).

Turn the gas control knob until the minimum flame position is reached. Check the setting pressure at minimum rate. The pressure should be (3.0mbar Nat) or (10.0mbar Propane). If necessary adjust the minimum flow adjusting screw clockwise (with a small screwdriver) to reduce the flow or anticlockwise to increase the flow. (See Fig.12).

Depress and turn the control knob clockwise until the pilot position is reached. The stove will go out and the pilot will remain lit. Remove the pressure gauge from the test point sealing screw, and replace screw.

Replace the gas valve, control and adjustment covers.

Turn on to the maximum gas rate and check for gas soundness.

TO TURN THE STOVE OFF

Turn the gas control knob to the minimum gas rate position, slightly depress the knob and continue turning to the pilot position. The fire will go out, and the pilot will remain lit and may be left on permanently.

TO TURN THE STOVE AND PILOT OFF

Turn the stove off as described. Depress the control knob, turn to the off position and the pilot will go out.

Check for Clearance of Products of Combustion

Ensure that all doors and windows of the room are closed.

Light the stove as described. Leave on maximum rate for five minutes.

If there is a fan in a nearby room then the spillage test must be repeated with the fan turned on and any interconnecting doors between the stove and the fan location left open.

A spillage test as detailed in BS:5440 must be carried out after 5 minutes as follows:- By holding a smoke match so that match head is approximately 3mm up inside the lower edge of the draught diverter. Spillage is indicated by smoke being displaced outwards from the draught diverter. If in doubt repeat after a further 10 minutes.

If spillage is detected the chimney may be faulty. The fault must be corrected before leaving the stove installed.

If the fault cannot be corrected turn off and disconnect the gas supply to the stove and seek expert advice.

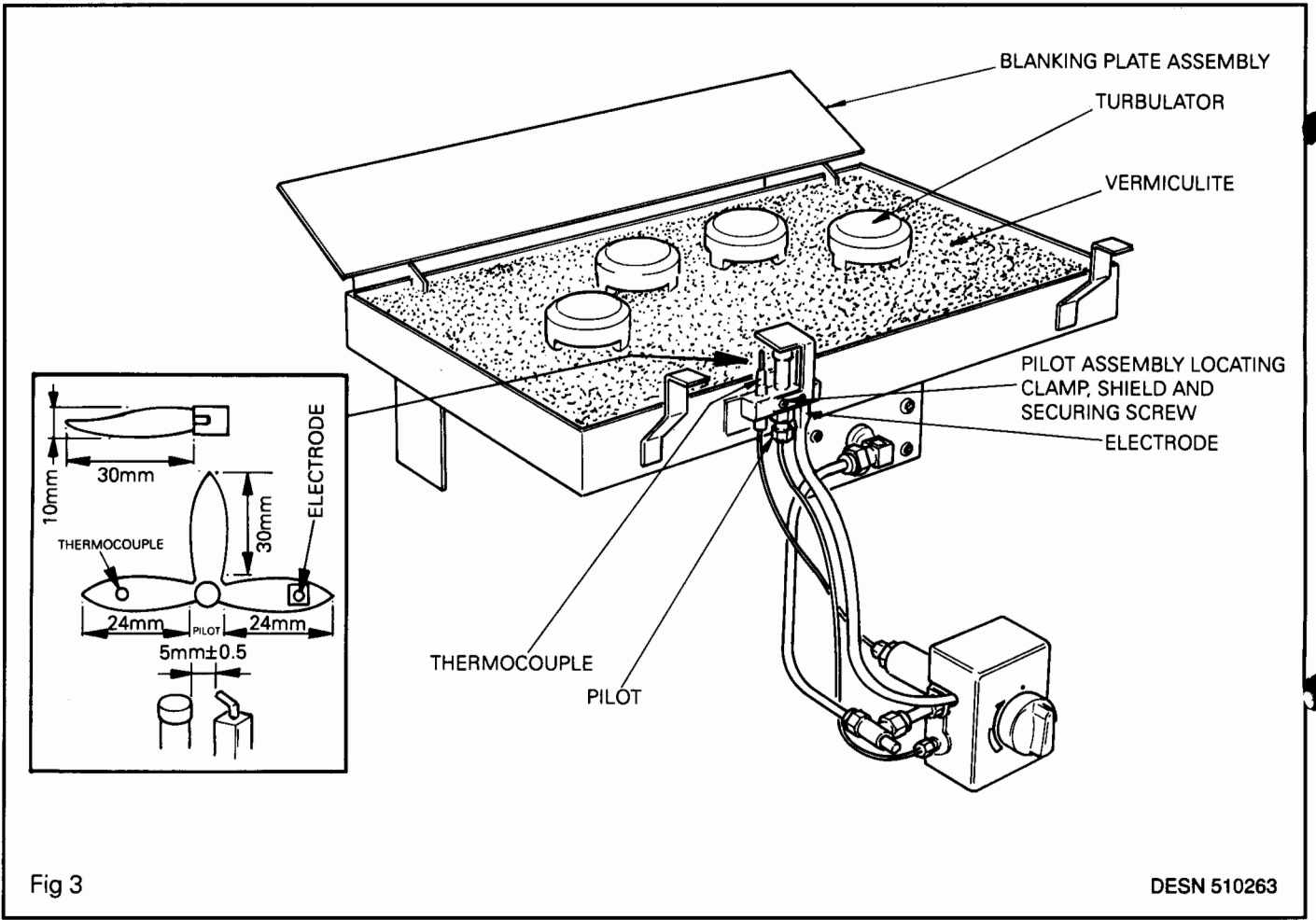

Fig 3

DESN 510263

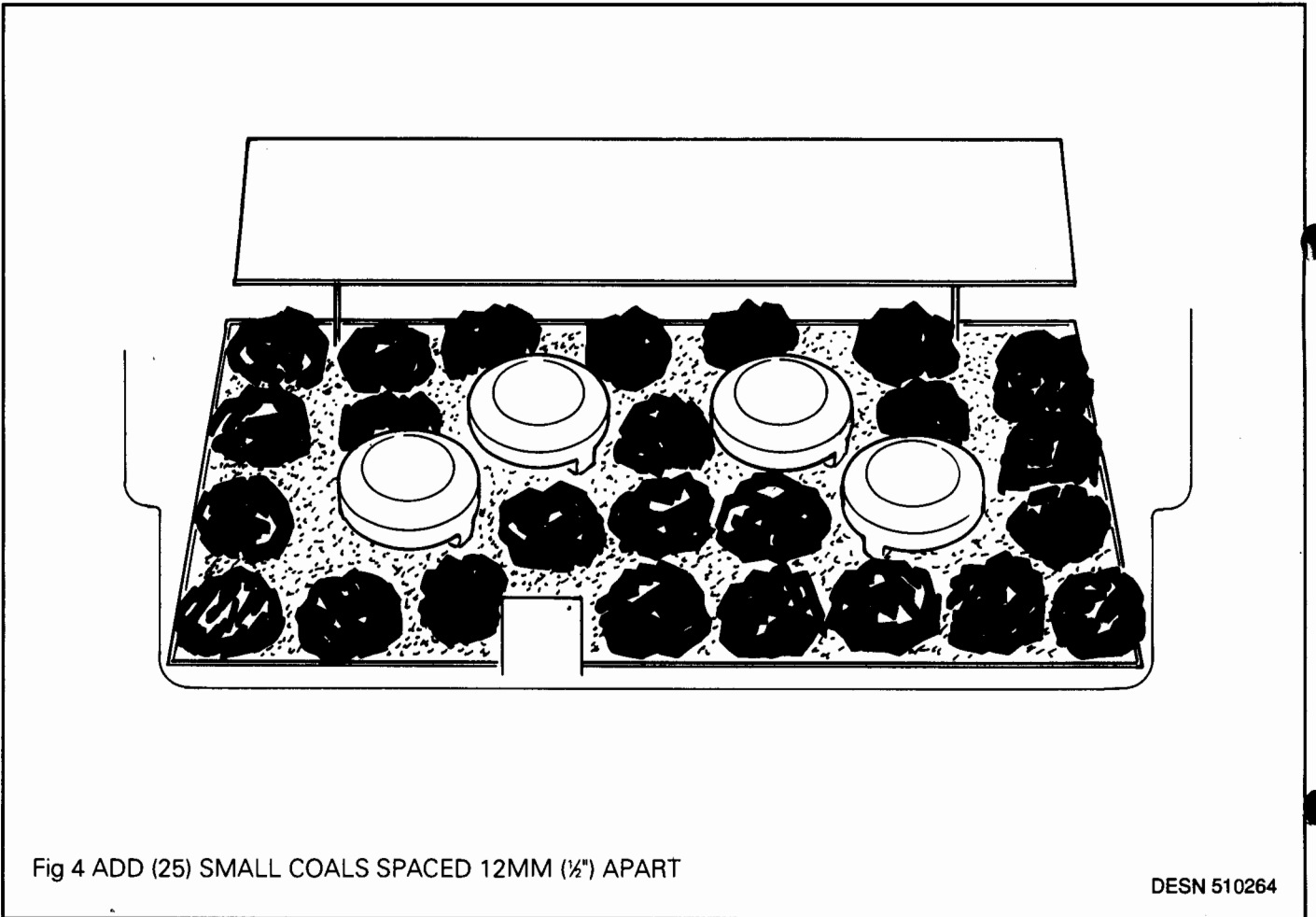

Fig 4 ADD (25) SMALL COALS SPACED 12MM (1/2") APART

DESN 510264

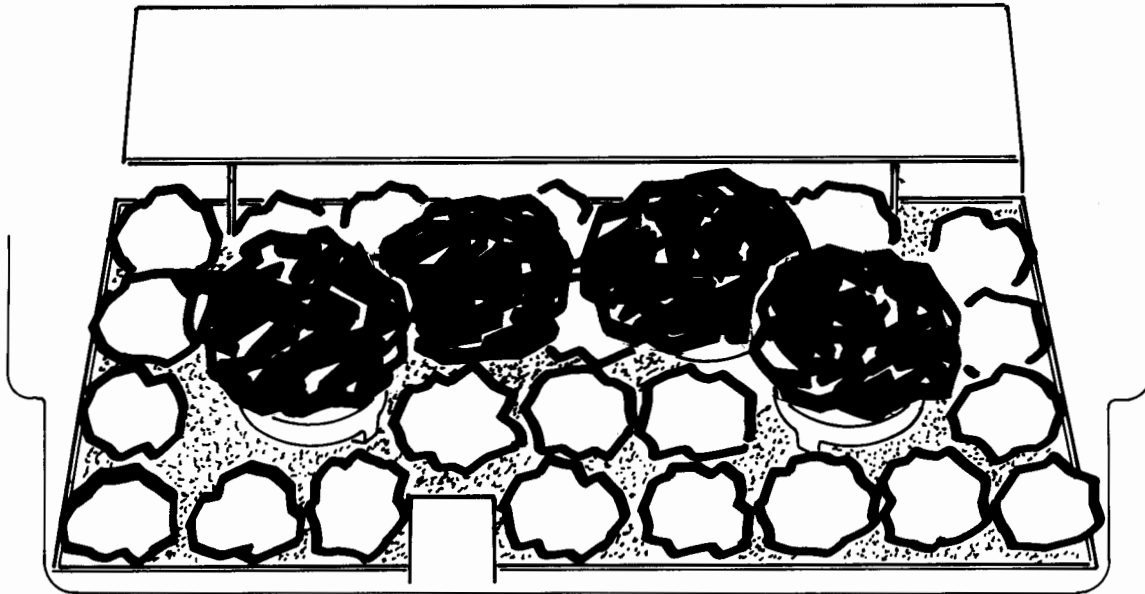

Fig 5 ADD (4) LARGE COALS ON THE
TOP OF THE TURBULATORS

DESN 510265

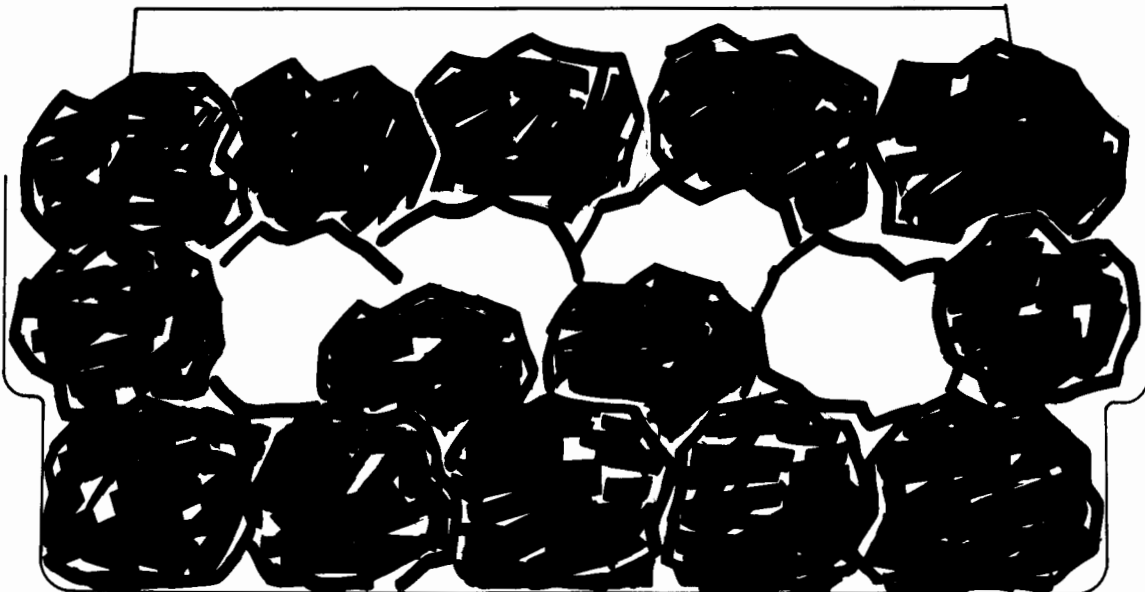

Fig 6 ADD (14) LARGE COALS

DESN 510266

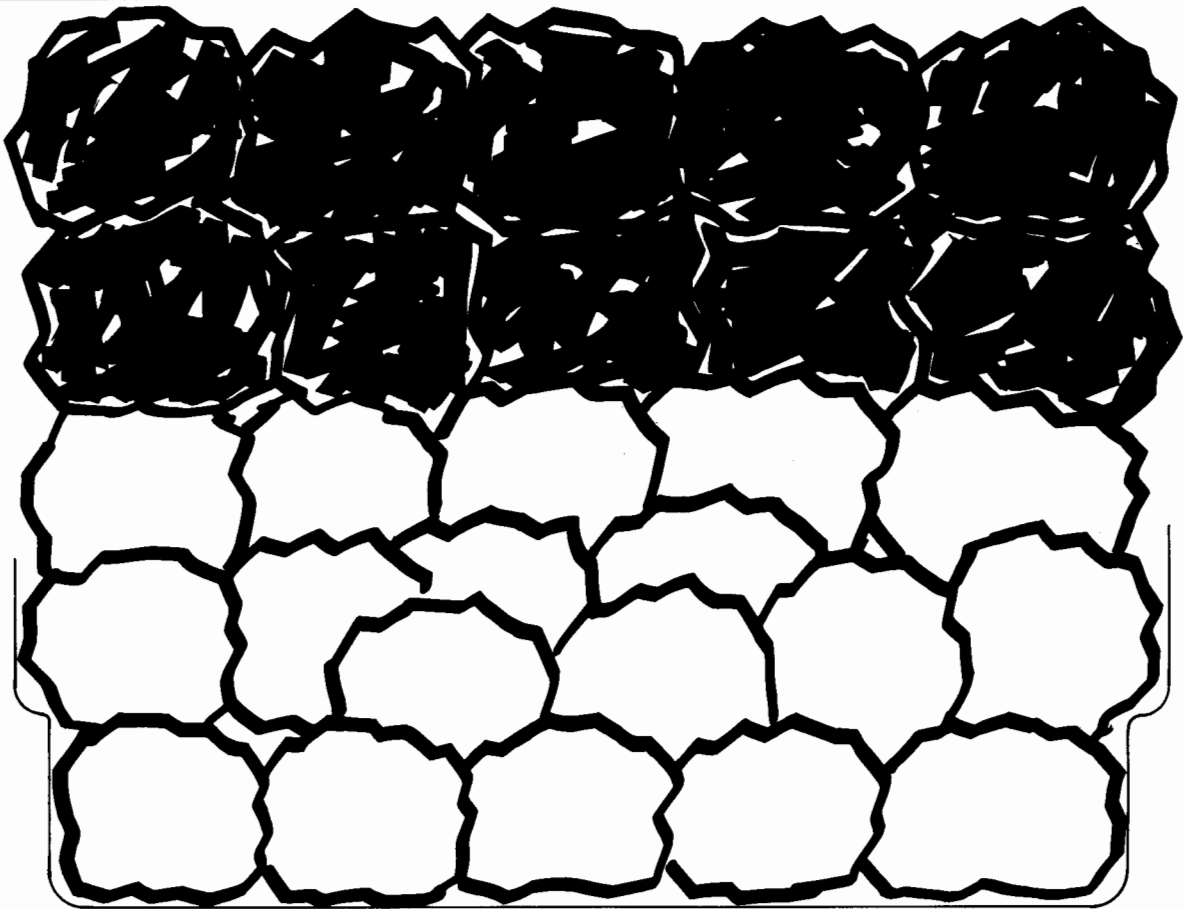

Fig 7 ADD 10 LARGE COALS

DESN 510267

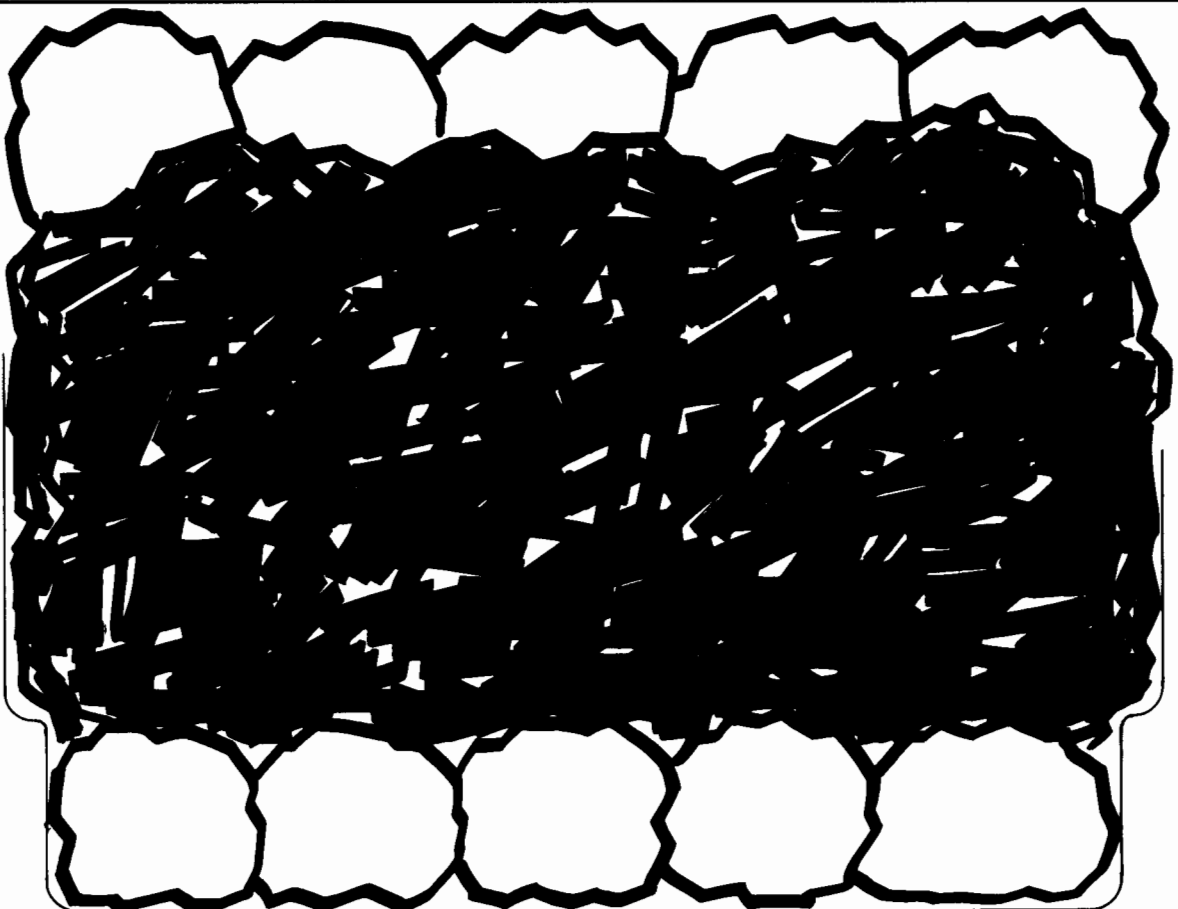

Fig 8 ADD 17 LARGE COALS

DESN 510268

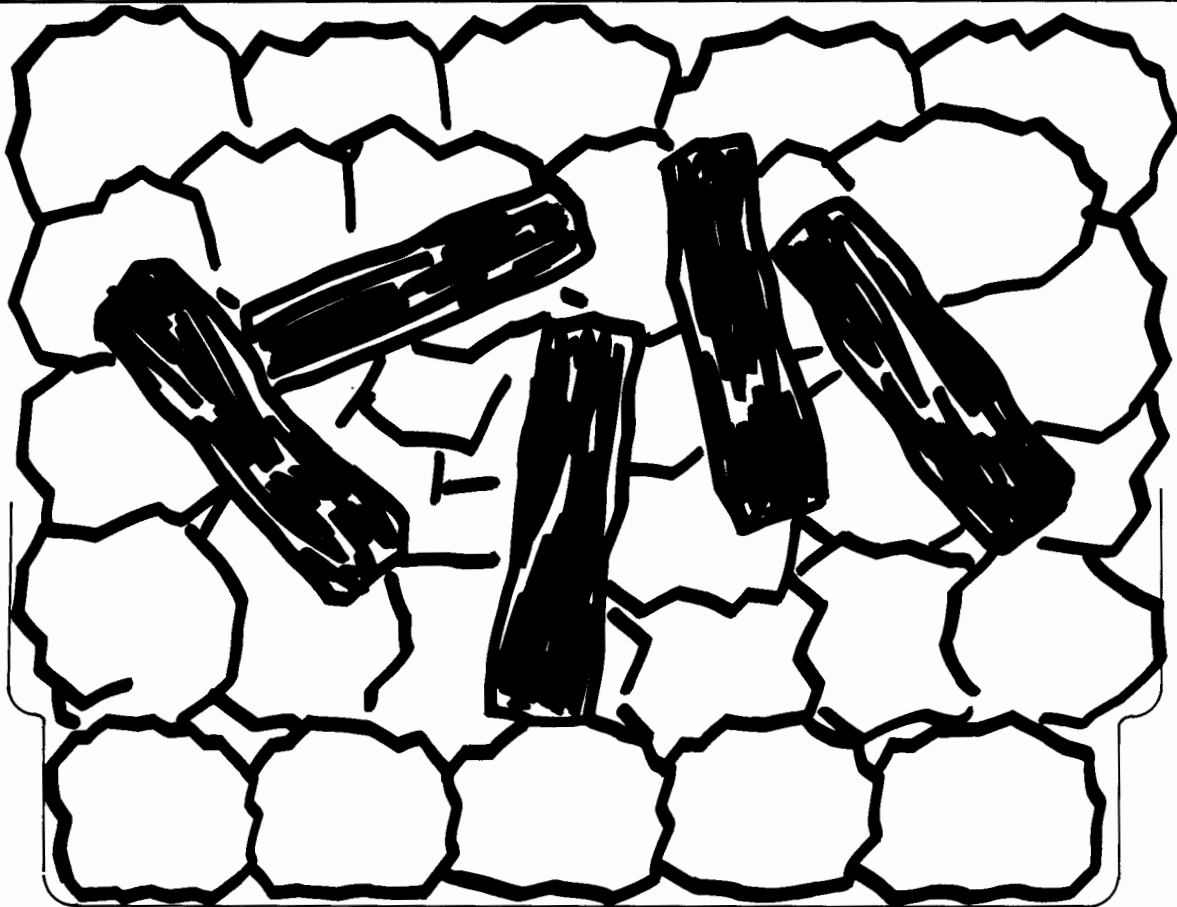

Fig.9 ADD (5) FINGER COALS

DESN 510269

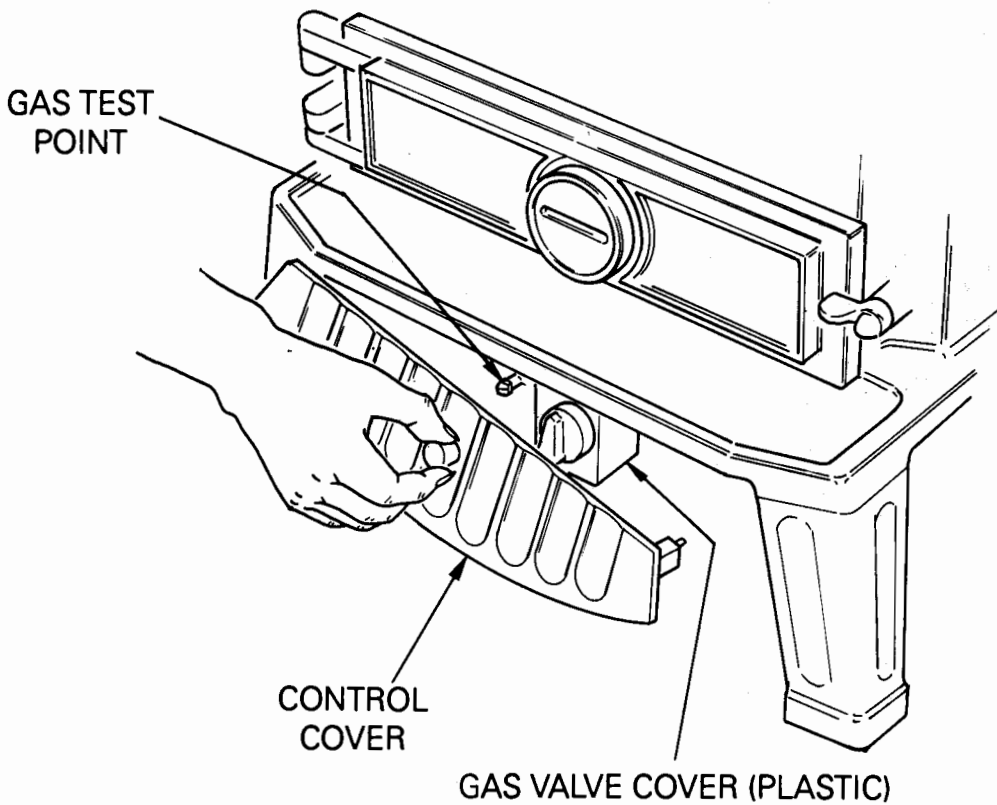

Fig.10

DESN 510273

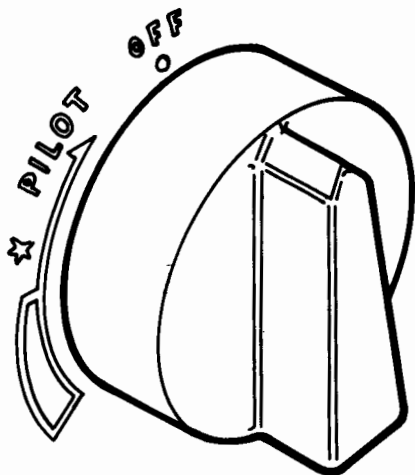

Fig.11

DESN 510133

INSTRUCT THE USER

Hand over the Users Instructions to the user and explain how to light and operate the appliance.

Impress upon the user that the coals must be located in accordance with the instructions and that the appliance **MUST NOT** be operated with the stove doors open. The appliance should be serviced at regular intervals by a competent person to ensure safe operation.

Point out the removable warning labels which the customer must remove and read.

Advise the user that any smells emitted from the stove on initial lighting will quickly clear away with use.

The door tool must be stored in a safe place out of the reach of children.

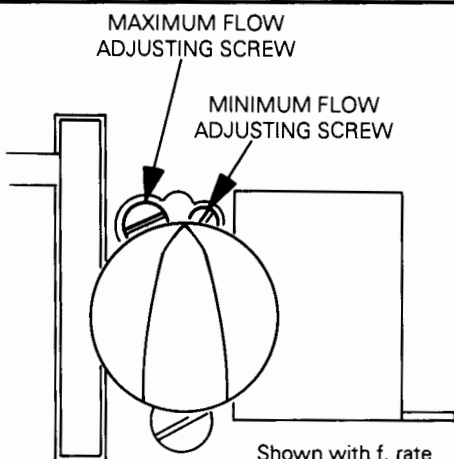

Fig.12

Shown with f. rate
adjustment cover
removed DESN 510134

SERVICING

It is recommended that the stove is inspected/serviced annually by a competent person. (e.g. A Corgi Registered Installer).

After any servicing ALWAYS check for gas soundness.

SERVICING PROCEDURE

Ensure that the stove is cold.

Isolate the gas supply to the stove.

Hands should be washed after handling coals (If gloves are not used).

Open the door of the stove (using the tool supplied).

Carefully remove all coals from the fire and inspect for Damage/Breakage. Clean any excessive soot from the coals with a soft brush. Check the surface of the ceramic bed for chimney debris and remove by hand.

Clean any soot deposits from the surface of the ceramic bed with a soft brush.

A VACUUM CLEANER MUST NOT BE USED, as this could also remove the vermiculite granules.

If necessary clean the pilot injector as follows:

Remove the control cover (See fig.9).

Disconnect gas supply to control valve.

Remove Turbulators (See fig.3).

Remove burner rear spacer plate (See fig.3).

Remove burner assembly tray location and securing screw (See fig.3).

Lift out carefully burner assembly tray and retain vermiculite granules.

Undo the pilot pipe connection at the pilot burner.

Remove pilot assembly securing screw (See fig.3).

Remove pilot assembly locating clamp and shield (See fig.3).

Remove thermocouple at pilot burner.

Remove pilot and clean.

DO NOT USE WIRE BRUSH

RE-ASSEMBLE PARTS IN REVERSE ORDER.
CAREFULLY REPLACE COALS AS DESCRIBED PREVIOUSLY.

REPLACEMENT OF PARTS

Ensure the stove is cold.

Isolate the gas supply to the stove.

On completion ALWAYS check for gas soundness.

Hands should be washed after handling coals. (If gloves are not used).

Open the door of the stove (using tool supplied).

Remove Control Cover (See fig.9).

Disconnect gas supply to Control Valve.

Carefully remove the coals from the stove.

Remove the Turbulators (See fig.3).

Remove the Burner Rear Spacer Plate (See fig.3).

Remove the Burner Assembly Tray Location and Securing Screw (See fig.3).

Carefully lift out the Burner Assembly Tray and retain vermiculite granules.

The following components can now be replaced, as follows:

Gas Valve (Including Piezo Ignitor).

Disconnect the Thermocouple, the Injector and Pilot Feed Pipes at the Gas Valve.

Disconnect the Piezo Ignitor Lead at the Electrode.

Remove the Gas Valve Control Knob by pulling forward.

Remove the Gas Valve Securing Screw.

Remove the Gas Valve.

Replace with new valve and re-assemble in reverse order, carefully replace the coals as described in 'LAYING THE FUEL BED'.

CHECK THE MAXIMUM AND MINIMUM FLOW RATE SETTING PRESSURES DESCRIBED IN '**TO LIGHT THE STOVE**'.

Main Burner Injector

Disconnect the Main Burner Injector Feed Pipe at the Injector, unscrew Main Injector.

Replace with new Injector and re-assemble in reverse order, carefully replace the coals as described in 'LAYING THE FUEL BED'.

Thermocouple

Disconnect the Thermocouple at the Gas Valve.

Remove the Pilot Assembly Securing Screw (See fig.3).

Remove the Pilot Assembly Locating Clamp and Shield (See fig.3).

Remove the Thermocouple at the Pilot Bracket.

Replace with new Thermocouple and re-assemble in reverse order, carefully replace the coals as described in 'LAYING THE FUEL BED'.

Ignition Electrode

Remove the Piezo Ignitor Lead from the Electrode.

Remove the Pilot Assembly Securing Screw (See fig.3).

Remove the Pilot Assembly Locating Clamp and Shield (See fig.3).

Remove the Electrode at the Pilot Bracket.

Replace with new Electrode. Check that the spark gap is 5.0 ± 0.5 mm (see Fig.3) and re-assemble in reverse order, carefully replace the coals as described in 'LAYING THE FUEL BED'.

SHORT LIST OF SPARE PARTS

The following Spare Parts are available from your Distributor:

Description	Makers Part Number
1. Gas Valve complete	FG4M 420285
2. Pilot Injector - NG	FG4M 420499
- PROPANE	FG4M 420505
3. Pilot Assembly Locating Clamp	FG4M 520504
4. Burner Injector - NG	FG4M 420376
- PROPANE	FG4M 412026
5. Thermocouple	FG4M 420502
6. Piezo Ignitor C/W Electrode Lead	FG4M 420310
7. Control Knob	FG4M 420308
8. Control Valve Cover	FG4M 420309
9. Pilot Burner Head - NG	FG4M 420497
- PROPANE	FG4M 410097
10. Spark Electrode	FG4M 420498
11. Turbulator	FG4M 420450
12. Coals Pack	HG1M 412039
13. Vermiculite Pack	FG4M 412040
14. Door Tool	HS9M 47520 COMP

THEY SHOULD BE FITTED **ONLY** BY A COMPETENT PERSON (e.g. A CORGI Registered Installer).

FAULT FINDING CHART

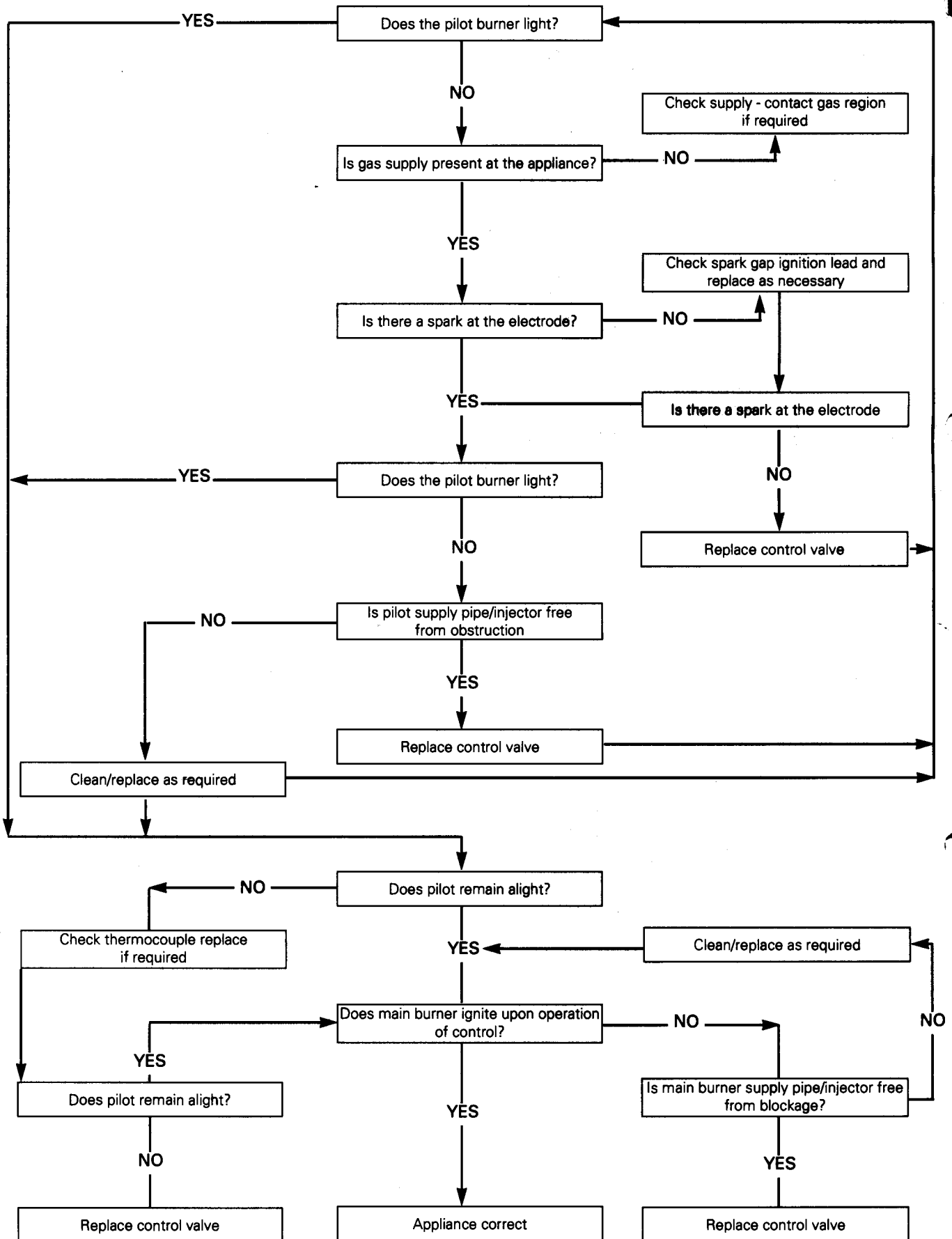

SPARE PARTS LIST

- | | | | |
|----|-----------------------------------|----|-----------------------------------|
| 1 | Control Cover | 36 | Hinge Stud |
| 2 | Roll Pin M5 x 20 | 37 | Hinge Pin |
| 3 | Data Plaque | 38 | Hinge Stud |
| 4 | Drive Screw 1/8" Dia Hammer Rivet | 39 | Hinge Cap |
| 5 | Ashpit Door | 40 | Grub Screw M5 x 8 LG |
| 6 | Rope 13 Dia x 810 LG | 41 | Firedoor |
| 7 | Washer M5 Plain | 42 | Ashpit Door Hinge Pin |
| 8 | Screw M5 x 8 LG Pozi Pan | 43 | Grub Screw M5 x 8 LG |
| 9 | Valve Mounting Bracket | 44 | Allthread M8 x 38 LG |
| 10 | Control Cover Support Bracket | 45 | Drive Screw 1/8" Dia Hammer Rivet |
| 11 | Washer M6 Plain | 46 | Warning Label |
| 12 | Screw M6 x 10 Hex HD | 47 | Spin Valve |
| 13 | Leg | 48 | Knob |
| 14 | Screw M8 x 25 Hex HD Set | 49 | Lighting Instructions |
| 15 | Washer M8 Plain | 50 | Control Cover Location Bracket |
| 16 | Base Plate | 51 | Washer M6 x 14 O/D x 0.8 |
| 17 | Side Plate RH | 52 | Screw M6 x 16 Pozi Pan HD |
| 18 | Operating Tool | 53 | Square Nut M8 |
| 19 | RH Throat Restrictor Support | 54 | Roll Pin 1/8" x 3/4" LG |
| 20 | Draught Diverter | 55 | Horizontal Channel |
| 21 | Rope Seal 9 Dia x 550 | 56 | Firedoor Glass 225 x 292.5 x 5 |
| 22 | Back Plate | 57 | Vertical Channel |
| 23 | Top Plate Assembly | 58 | Glass Retaining Frame |
| 24 | Throat Restrictor Plate | 59 | Door Catch Cap |
| 25 | Screw M6 x 16 LG Hex HD Set | 60 | Door Catch |
| 26 | Washer M6 Plain | 61 | Shoulder Screw Stud |
| 27 | LH Throat Restrictor Support | 62 | Shoulder Screw |
| 28 | Nut M6 Full | 63 | Door Catch Cap |
| 29 | Allthread Stud M6 x 30 LG | 64 | Door Catch |
| 30 | Washer M6 Plain | 65 | Shoulder Screw Stud |
| 31 | Nut M6 Full | 66 | Shoulder Screw |
| 32 | Side Plate LH | 67 | Front Plate |
| 33 | Screw M6 x 25 LG Hex HD Set | 68 | Washer M5 Plain |
| 34 | Washer M6 Plain | 69 | Screw M5 x 12 LG Hex HD |
| 35 | Hinge Cap | | |

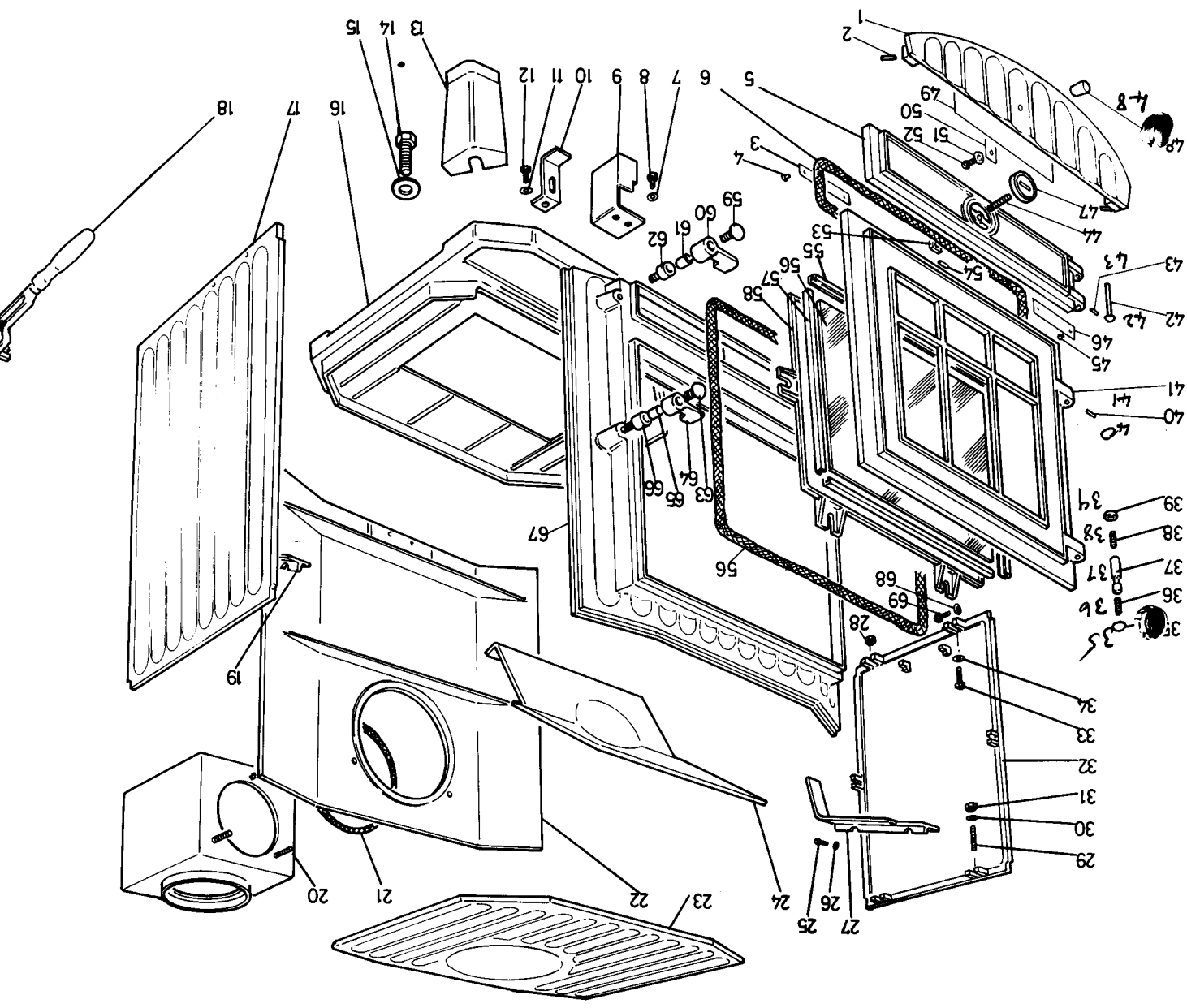

SPARE PARTS LIST - GAS CONTROL ASSEMBLY

- | | | | |
|----|---|----|--|
| 1 | Pressure test Point | 15 | M6 Washer Plain |
| 2 | Feed Pipe Short | 16 | Nut M6 Full |
| 3 | Spark Generator Lead | 17 | Spreader Plate |
| 4 | Spark Generator | 18 | Turbulator |
| 5 | Control Cover | 19 | Blanking Plate Assembly |
| 6 | Knob | 20 | Flame Head NG
Flame Head Propane |
| 7 | Gas Valve | 21 | Thermocouple |
| 8 | Burner Injector Bray 82/900 NG
Burner Injector Bray 92/320 Propane | 22 | Pilot Injector NG N04
Pilot Injector Propane N028 |
| 9 | Injector Mounting Plate Assy NG | 23 | Ceramic Venturi RH |
| 9A | Injector Mounting Plate Assy Propane | 24 | Burner Tray Assy |
| 10 | Screw M4 x 10 Pan HD Tapitte | 25 | Ceramic Venturi LH |
| 11 | Clamp | 26 | Gasket |
| 12 | Spark Electrode | 27 | Olive |
| 13 | Clamp Screw | 28 | Feed Pipe Long |
| 14 | Pilot Shield | | |

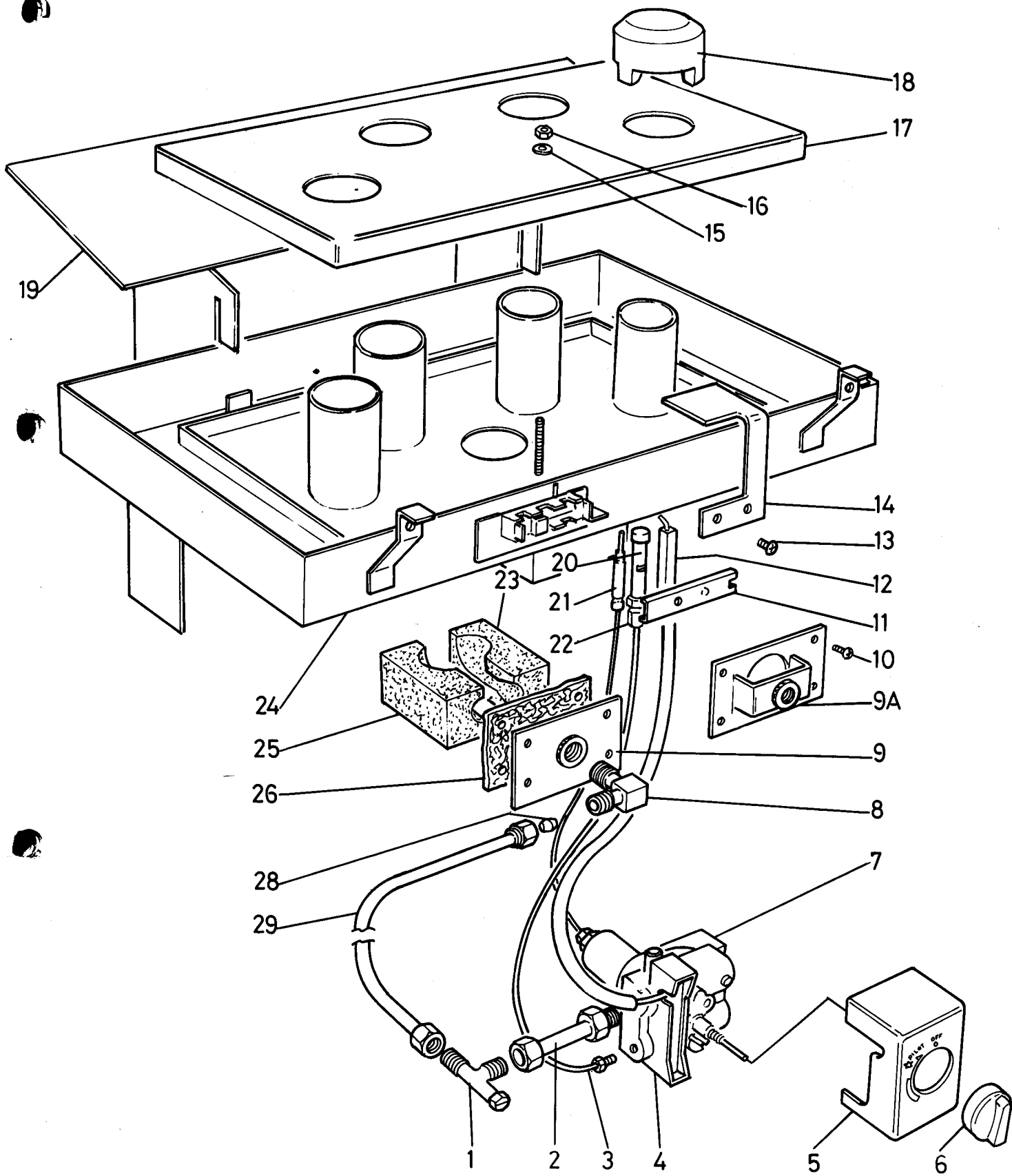

SPARE PARTS



COALS:- Black, 25 Small
Black, 45 Large
Black, 5 Finger

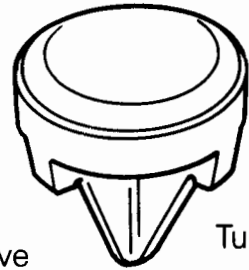

Turbulator

Gas Control Valve
Complete with generator

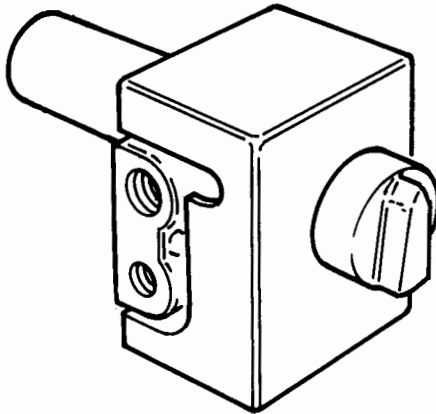

Gas Control
Valve Knob

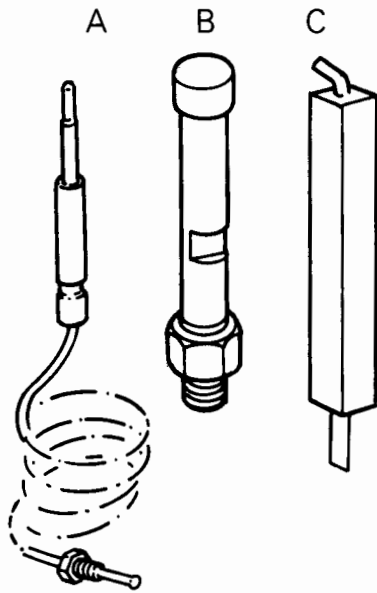

- A. Thermocouple
- B. Pilot Assembly
Complete with injector
- C. Spark Ignition Assembly

Burner Injector



DESN 510135A

With Coalbrookdale's policy of continuous product improvement, the Company reserves the right to change specifications and make Modifications to the appliance described and illustrated at any time.

COALBROOKDALE



Glynwed Consumer Products Ltd.

PO Box 30 Ketley Telford Shropshire TF1 4DD

Telephone (0952) 642000 Telex 35196 Fax (0952) 641961