

## **WARNING**

**This information is a copy of an original archive, therefore Aga cannot be held responsible for its continued accuracy.**

# THE COALBROOKDALE GS2i

## Propane Gas Model

## Installation and Servicing Instructions

CE Cat I<sub>2H</sub> (G20) For use in GB and IE at a supply pressure of 20mbar

### THIS APPLIANCE MUST BE INSTALLED IN ACCORDANCE WITH THE RULES IN FORCE

#### Consumer Protection Act 1987

As manufacturers and suppliers of cooking and heating products, in compliance with Section 10 of the Consumer Protection Act 1987, we take every care to ensure, as far as is reasonably practicable, that these products are so designed and constructed as to meet the general safety requirement when properly used and installed. To this end, our products are thoroughly tested and examined before despatch.

**IMPORTANT NOTICE:** Any alteration that is not approved by Aga-Rayburn could invalidate the approval of the appliance, operation of the warranty and could also affect your statutory rights.

#### Control of Substances - Health and Safety Important

This appliance may contain some of the materials that are indicated. It is the Users/Installers responsibility to ensure that the necessary

personal protective clothing is worn when handling where applicable, the pertinent parts that contain any of the listed materials that could be interpreted as being injurious to health and safety, see below for information.

**Firebricks, Fuel beds, Artificial Fuels** - when handling use disposable gloves.

**Fire cement** - when handling use disposable gloves.

**Glues and Sealants** - exercise caution - if these are still in liquid form use face mask and disposable gloves.

**Glass Yarn, Mineral Wool, Insulation Pads, Ceramic Fibre, Kerosene Oil** - may be harmful if inhaled. May be irritating to skin, eyes, nose and throat. When handling avoid contact with skin or eyes. Use disposable gloves, face-masks and eye protection. After handling wash hands and other exposed parts. When disposing of the product, reduce dust with water spray, ensure that parts are securely wrapped.

GAS DATA	
	NAT GAS
<b>MAX</b>	<b>kW</b>
HEAT INPUT (GROSS)	10.3
HEAT OUTPUT (GROSS)	6.11
<b>MIN</b>	<b>kW</b>
HEAT INPUT (GROSS)	4.7
HEAT OUTPUT (GROSS)	2.55

Gas Connection 8mm OD Tubing

Flue Spigot size - 125mm

Ignition - piezo spark ignitor

Spark Gap 2.5 - 4mm (factory set non-adjustable)

Appliance weight 115kg

## INTRODUCTION

The Coalbrookdale GS2i is factory set to operate on **natural gas only** and **must not** be used on any other gas.

Due to the newness the stove may give off a slight smell for a short period after commissioning. This is quite normal and will disappear after a few hours operation, open windows and doors if required.

The Coalbrookdale GS2i has two access doors as part of its design. The glass fronted door is for access to the coals and apart from initial commissioning of the stove, or in case the pilot is required to be lit with a taper due to malfunction of the spark ignition system. **UNDER NO CIRCUMSTANCES MUST THE STOVE BE OPERATED WITH THE DOOR OPEN OR IF THE GLASS PANEL IS CRACKED OR BROKEN.**

The Coalbrookdale GS2i has been designed similar to a solid fuel stove to relevant safety standards, but during use, many of the parts of the appliance can become HOT to touch. We recommend that you provide and secure a fireguard complying with BS.6539 when the room is used by elderly, infirm or young persons.

### SETTING PRESSURE (COLD)

NATURAL
MAX
mbar
13.7 ±0.75
Burner Injector Nat-Cat 82/800
Pilot Injector Nat-NG 9008

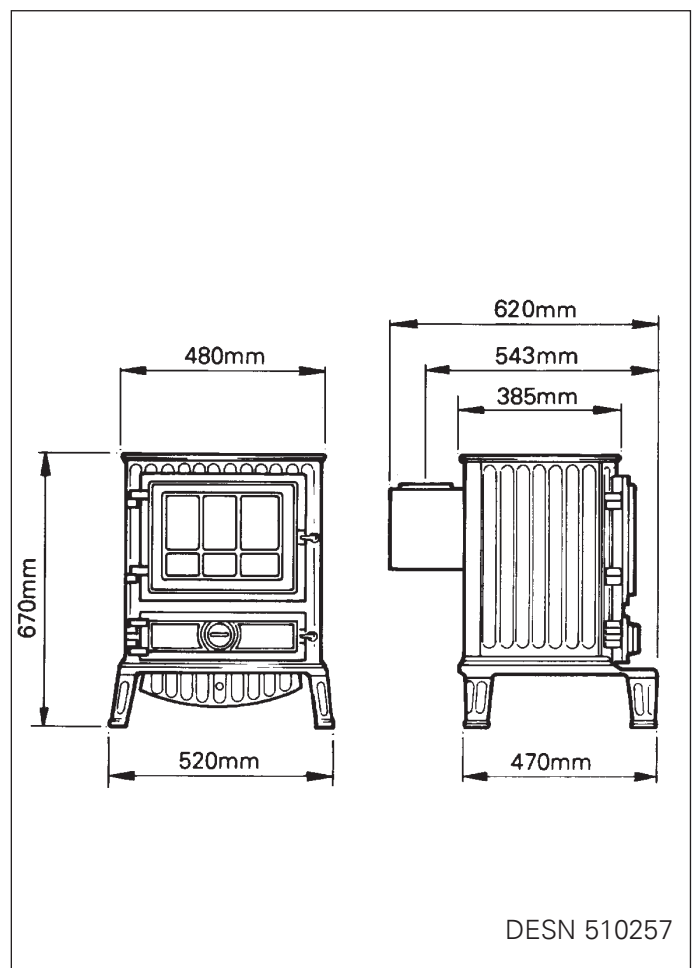

# INSTALLATION INSTRUCTIONS

The installation of the appliance must be in accordance with the relevant requirements of the Gas Safety (Installation and Use) Regulations 1994, Building Regulations and the Building Standards (Scotland) (Consolidation) Regulations. It should be in accordance also with any relevant requirements of the local Gas Region and Local Authority, and the relevant recommendations of the following current British Codes of Practice & British Standards.

**BS.6891:** Installation of pipes and meters. Low pressure installation pipes.

**BS.5440:** Part 1 Flues & Part 2 Air Supply

**BS.5871:** Part 1 Installation of Gas Fires, Convector Heaters, Fires/Back Boilers.

**BS.6461:** Codes of Practice for factory-made insulated chimneys for internal application.

**BS.8303:** Solid fuel appliance flue system

In your own interest and that of safety to comply with the law all gas appliances should be installed by a competent person (Corgi Registered) in accordance with the above regulations and with these instructions. Failure to install the appliance correctly could lead to prosecution.

## THE LOCATION

The stove must not be installed into a recess smaller than 650mm wide and 950mm high.

To ensure adequate circulation of convected air it is recommended that the stove should not be installed into a recess of a depth any greater than 410mm.

The appliance must be installed on a base of incombustible material, at least 12mm thick, extending to at least the front of the stove supporting legs, and to 85mm beyond each side of the stove (650mm). No clearance is required in front of the hearth.

The stove must be installed with a hearth capable of withstanding a maximum temperature of 150°C. Conglomerate marble, marble and tiled surrounds can meet this requirement.

An area 950mm high by 650mm wide behind the appliance must be on solid non combustible material (See fig. 1).

Clearance for Shelves: A wooden shelf may be fitted above the stove. The underside of the combustible shelf above the top of the stove should be dimensioned accordingly.

Depth of Shelf	Height to underside of shelf Y
150mm	620mm
175mm	635mm
200mm	660mm
225mm	710mm
250mm	760mm
275mm	810mm
300mm	870mm

NOTE: IF THE FLUE PIPE PASSES THROUGH THE SHELF REFER TO SECTION 'SHIELDING OF FLUE PIPES'.

ALTERNATIVE  
(USING REGISTER PLATE)

SEAL PLATE TO  
WALL WITH  
SUITABLE  
SEALANT.

REGISTER PLATE

SEAL FLUE TO SPIGOT  
WITH ROPE AND CEMENT  
(CEMENT SUPPLIED  
IN PACK)

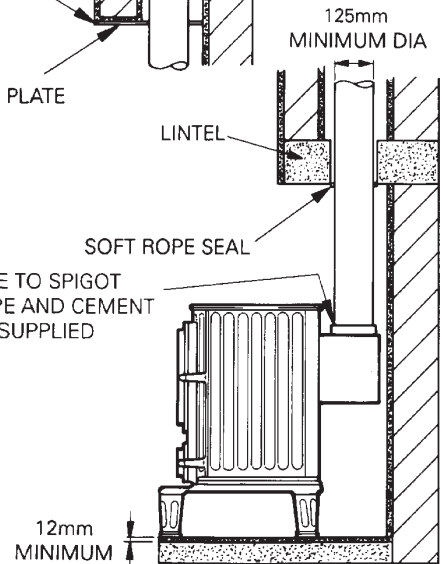

DESN 510258 'A'

CLEARANCE TO BE MINIMUM OF 75mm

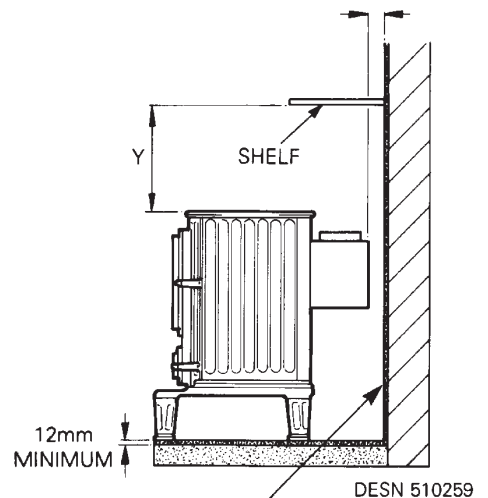

DESN 510259

THIS PART OF THE WALL AT THE BACK AND SIDE OF THE APPLIANCE TO BE SOLID NON-COMBUSTIBLE MATERIAL WITH A THICKNESS OF AT LEAST 25mm IF THE MINIMUM CLEARANCES FOR COMBUSTIBLE MATERIALS CANNOT BE OBTAINED.

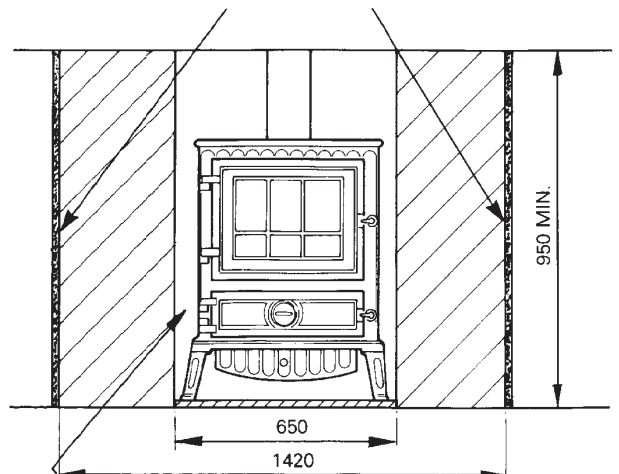

DESN 510924

THIS AREA BEHIND THE APPLIANCE MUST BE OF SOLID NON-COMBUSTIBLE MATERIAL (EG. BRICK).

## THE FLUE - See fig 1

The appliance may be used/connected to a solid fuel appliance flue system having a diameter not less than 125mm.

Alternatively, detailed recommendations for gas fluing are given in current issue BS.5258: Part 1.

The following notes are intended to give general guidance.

The cross sectional area of the flue serving the stove must not be less than the area of the flue outlet of the stove and be of at least 3m effective high from the floor level, it must not be less than 125mm internal diameter.

### Flue Pipes

Flue pipes and fittings should be constructed from one of the following materials.

- a) Cement to BS.567
- b) Aluminium or stainless steel to BS.715
- c) Cast iron or mild steel to BS.41 acid resistant vitreous enamelled lined.

If a chimney is to be used, it **MUST** be one that is composed of or lined with a non-porous acid resistant material (Chimneys lined with salt glazed earthenware pipes are acceptable, if the pipes comply with current issue of BS.65).

### Shielding of Flue Pipes

Flue pipes should:

- (a) be at least 25mm from any combustible material, or
- (b) where passing through a wall, floor or roof, be separate from any combustible material by a non-combustible sleeve enclosing an air space of at least 25mm around the flue pipe, or
- (c) where passing through a compartment wall or a compartment floor, be cased with non-combustible material with at least half the fire-resistance needed for the wall or floor (see Approved Document B3 Internal fire spread (structures)).

For double-walled flue pipe, the 25mm distance may be measured from the outside of the inner pipe.

### Factory-Made Insulated Chimneys

Factory-made insulated chimneys should be:-

- (a) constructed and tested to meet the relevant recommendations given in BS.4543 Factory-made insulated chimneys, Part 1: Methods of test for factory-made insulated chimneys and Part 2: Specification for chimneys for solid fuel fire appliances, and
- (b) installed in accordance with the manufacturers instructions or to meet the relevant recommendations of BS.6461: Installation of chimneys and flues for domestic appliances burning solid fuel (including wood and peat) and BS.7566 Parts 1 to 4 Installations of factory-made chimneys to BS.4543 for domestic appliances.

A flue pipe constructed to one of the standards in (a) to (c) should form the connections from the stove to lined chimneys,

If a brick chimney is to be used it **MUST** be swept prior to installation.

Before installing the stove, or inserting a liner, check that the flue is sound, free from obstruction and clean. If a register plate, restrictive plate or damper etc is fitted in the flue. It **MUST** be removed or locked fully open.

The flue should terminate in accordance with the relevant recommendations given BS.5440: Part 1.

The point of termination must not be within 600mm of an openable window, air vent or any other ventilation opening.

Check that the chimney serves only one appliance, and that the flue and associated connection joints are properly sealed.

## AIR SUPPLY

The room containing the appliance must have a permanent air vent or effective area of at least 15cm<sup>2</sup>. The vent must be to outside air or to an adjacent room having a permanent vent to outside air of the same area.

## EFFECT OF EXTRACTION FAN

If there is any type of extractor fan fitted in the same room as the stove, there is a possibility that if adequate air inlet area from outside is not provided, spillage of the products from the appliance flue could occur when the extractor fan is in operation. Where such installations occur, a spillage test as detailed in BS.5440: Part 1 must be carried out.

## GAS CONNECTION

The complete installation must be tested for soundness and purged as described in BS.6891.

The gas inlet to the stove is 8mm dia compression, and providing the distance from the service cock to the stove does not exceed 1.5m, 8mm dia rigid or semi-rigid supply pipe may be used.

Above this length, 15mm dia rigid or semi-rigid pipe should be used.

A service cock must be fitted adjacent to this appliance.

## APPLIANCE ASSEMBLY

### Unpacking

Remove all parts from inside the pack and ensure that no damage has occurred during delivery transit. If so, please contact your local stockist.

Items in Pack:

Instructions-Installation/Service and Operating

Turbulators (4)

Coals (15)

Door Locking Tool

Clay Aggregate

Cement (For sealing flue spigot)

Draught Diverter

Throat Restrictor

Control Cover

### Fit Draught Diverter

Secure draught diverter with nuts and washers provided (Fig. 2)

**IMPORTANT: Ensure sealing rope (factory fitted) is in position before locating draught diverter.**

### Fit Throat Restrictor

Secure throat plate with bolts, nuts and washers provided (Fig. 3).

## INSTALLING THE APPLIANCE

Position the appliance in accordance with the instruction given in the section 'LOCATION' and connect the flue pipe in accordance with the section 'THE FLUE'.

### FLEXIBLE PIPE/CONNECTIONS MUST NOT BE USED

Connect the stove to the gas supply. (See Gas Connection).

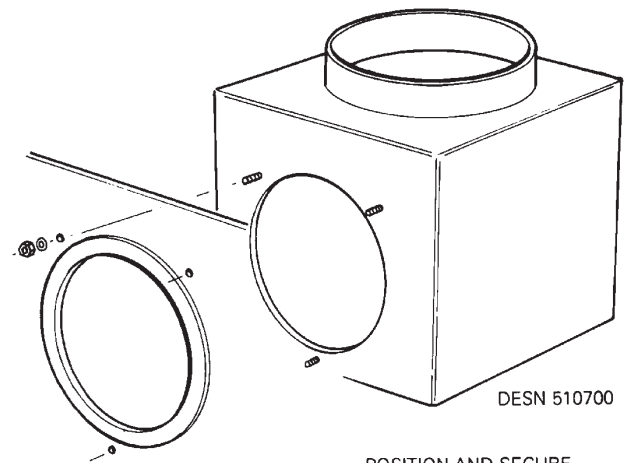

POSITION AND SECURE  
DRAUGHT DIVERTER  
TO REAR OF STOVE  
WITH NUTS AND  
WASHERS PROVIDED

FIG. 2

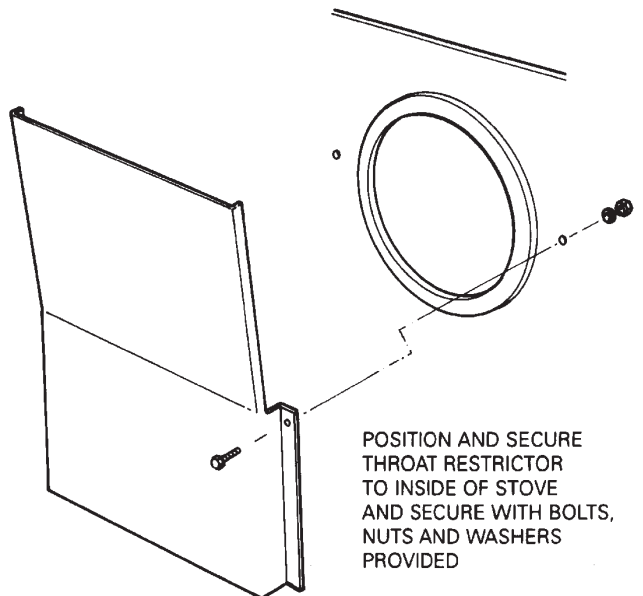

POSITION AND SECURE  
THROAT RESTRICTOR  
TO INSIDE OF STOVE  
AND SECURE WITH BOLTS,  
NUTS AND WASHERS  
PROVIDED

FIG. 3

DESN 510701

## LAYING THE FUEL BED

Open the door of the stove (using the tool supplied). See Fig. 4.

Position the rear blanking plate as illustrated in Fig. 5 and fit the ceramic turbulators over the aeration tubes (Fig. 6).

Pour the aggregate into the burner tray, as illustrated in Fig. 6.

**Do not compress** or tap down. Any excess should be kept and handed to the user for future use.

**NOTE:** The lower door on the stove is to ease serviceability and can be opened in the same way as the large door.

### Positioning the Coals

Carefully place the coals on the fuel bed as illustrated in figs. 7, 8, 9 and 10.

Close the door and lock (using the tool supplied).

**WARNING:** USE ONLY THE SIMULATED COALS SUPPLIED WITH THE APPLIANCE TO BUILD THE BED UNDER NO CIRCUMSTANCES USE EXTRA COALS OR PUT ANY OTHER MATERIAL ON THE FUEL BED.

DO NOT OPERATE THE STOVE WITH THE DOOR OPEN OR IF THE GLASS PANEL IN THE DOOR IS CRACKED OR BROKEN.

Hands should be washed after handling coals (if gloves are not used).

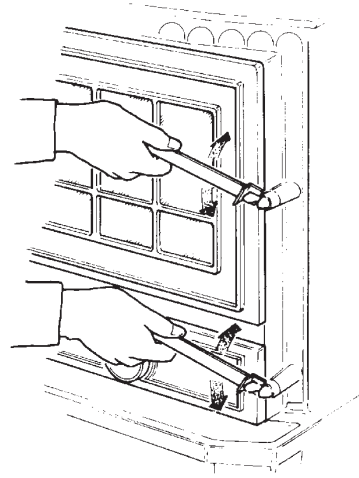

FIG. 4

DESN 510925

# LAYING THE FUEL BED

LOCATE THE REAR BLANKING PLATE AS SHOWN.

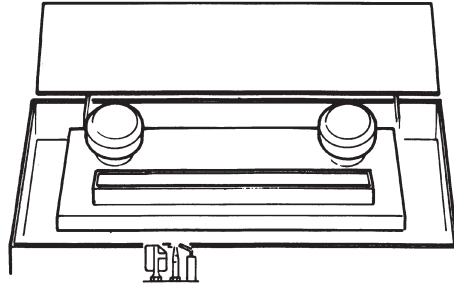

FIG. 5

DESN 510935

LOCATE THE TURBULATORS AS SHOWN.  
POUR THE CLAY AGGREGATE SUPPLIED INTO THE TRAY UNTIL IT IS FLUSH WITH THE TOP OF THE BURNER TRAY.

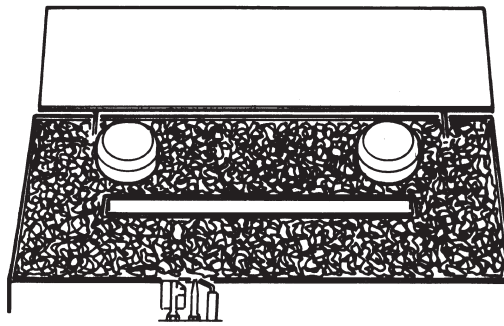

FIG. 6



DESN 510936

LOCATE 2 COALS ON TOP OF THE TURBULATORS AS SHOWN.

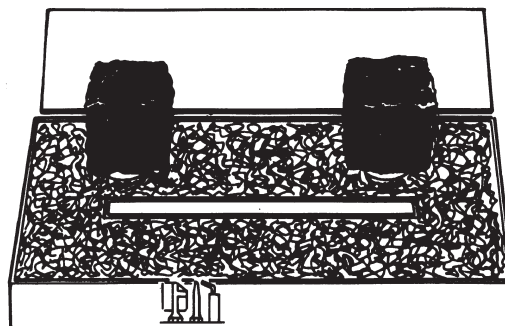

FIG. 7



DESN 510937

PLACE 4 COALS TO THE REAR OF THE BURNER TRAY AS SHOWN.

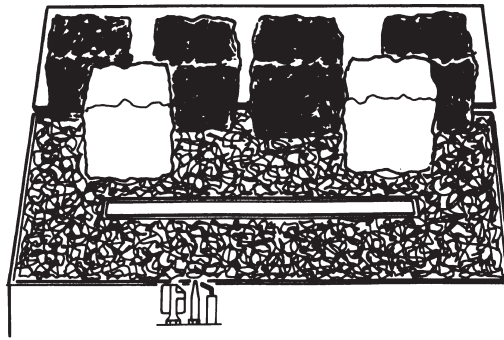

FIG. 8



DESN 510938 'A'

PLACE 3 COALS ONTO THE BURNER TRAY AS SHOWN.

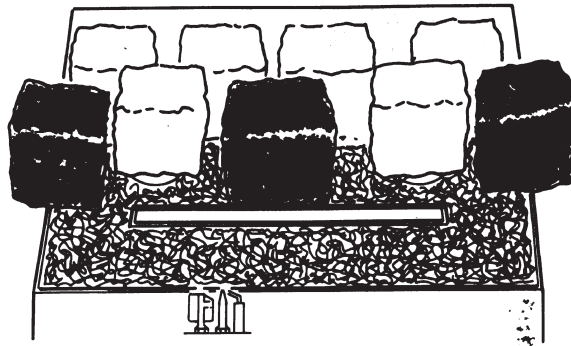

FIG. 9



DESN 510939 'A'

PLACE THE REMAINING 6 COALS ONTO THE BURNER TRAY AS SHOWN.

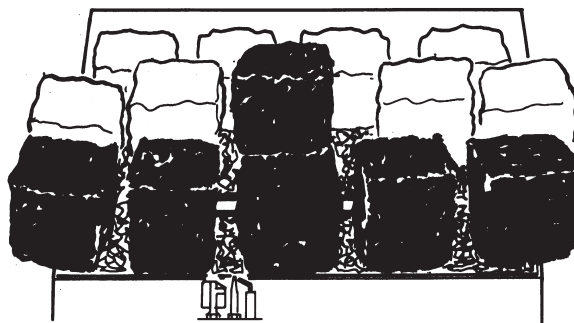
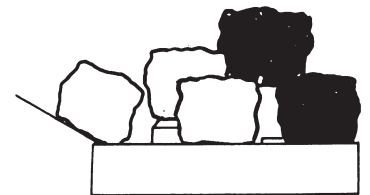

FIG. 10



DESN 510940 'A'



# COMMISSIONING AND TESTING

## NO SMOKING OR NAKED LIGHTS

The whole installation must be inspected and tested for soundness, and purged up to the gas service cock in accordance with BS.6891. Remove the pressure test point sealing screw on the burner feed pipe, located at the left hand side of the control valve, connect a suitable pressure gauge (See Fig. 11).

The control tap is marked with the following positions:-

OFF	●
PILOT ONLY	☆
MINIMUM	🔥
MAXIMUM	🔥

The stove is fitted with a piezo spark ignitor.

**Note: If the main burner or pilot are extinguished for any reason do not attempt to re-light the pilot for three minutes.**

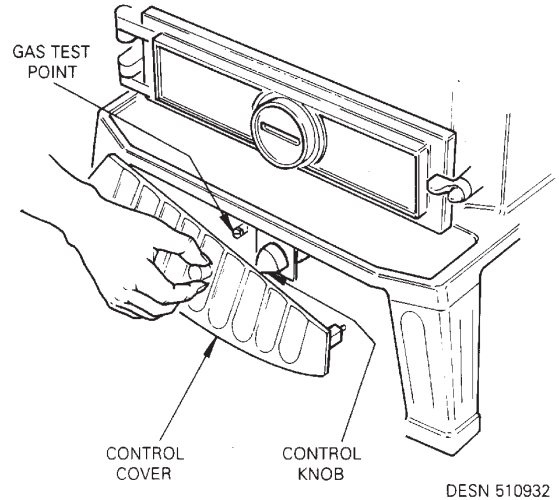

FIG. 11

## TO LIGHT THE PILOT

Remove the control cover. Ensure that the glass door is closed and locked and that the control knob is in the OFF (●) position (Fig. 12).

Fully depress the control knob and turn anti-clockwise (keeping the control knob fully depressed) until the pilot position (☆) is reached (Fig. 13). If the pilot has not lit repeat the operation.

Once the pilot is lit continue to hold in the control knob for a further 10-15 seconds to establish the pilot. When the control knob is released the pilot should remain alight. If the pilot fails to remain alight refer to fault finding section of this document.

If required the pilot may be lit by a long spill or taper as follows:

Open the door of the stove (using the tool supplied). (See Fig. 4).

Apply a lighted long spill or taper to the pilot (See Fig. 14) positioned at the front LH side of the burner tray.

Fully depress the control knob and turn anti-clockwise (keeping the control knob fully depressed) until the pilot position (☆) has been reached and the pilot should light.

Once the pilot is lit remove the long spill or taper, continue to hold the control knob for 10 to 15 seconds to establish the pilot. When the knob is released, the pilot should remain alight. If the pilot fails to remain alight, repeat the procedure, but hold knob in longer.

**When pilot is established close the door (using the tool supplied).**

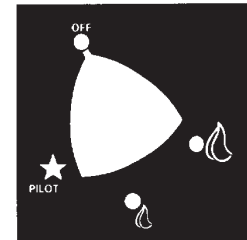

FIG. 12

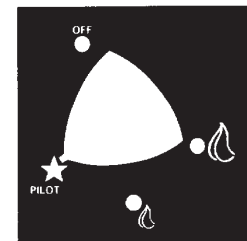

FIG. 13

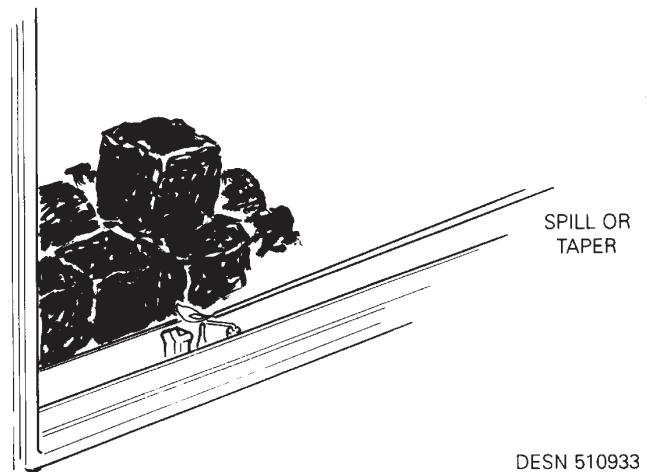

FIG. 14

## TO LIGHT THE STOVE

If the pilot is not already alight, follow procedure to light pilot.

Turn the control knob anti-clockwise to the full on position (☰) (See Fig. 15). The main burner will light. At this setting the pressure should be 13.7+/-0.75mbar with an inlet pressure of 20mbar.

Depress and turn the control knob clockwise to the pilot position (☞) (See Fig. 16). The stove will go out and the pilot will remain alight. Remove the pressure gauge and replace the test point sealing screw.

Turn stove to maximum setting (☹) (Fig. 17) and check for gas soundness.

FIG. 15

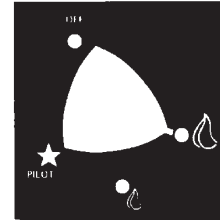

FIG. 16

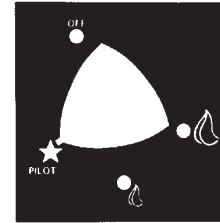
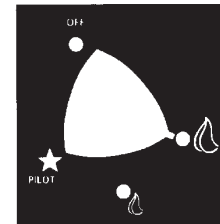

FIG. 17



## TO TURN STOVE OFF

Turn the gas control knob to the minimum gas rate position (☺) (Fig. 18), slightly depress the knob and continue turning to the pilot position (☞) (Fig. 19). The fire will go out, and the pilot will remain lit and may be left on permanently.

FIG. 18

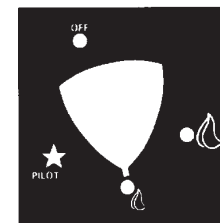
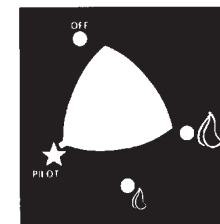

FIG. 19



## TO TURN STOVE AND PILOT OFF

Turn the stove off as described. Depress the control knob, turn to the off position (●) (Fig. 20) and the pilot will go out.

FIG. 20

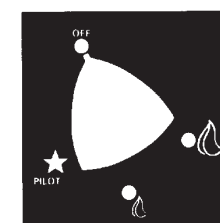

## CHECK FOR CLEARANCE OF PRODUCTS OF COMBUSTION

Ensure that all doors and windows of the room are closed.

Light the stove as described. Leave on maximum rate for 5 minutes.

If there is a fan in a nearby room then the spillage test must be repeated with the fan turned on and any interconnecting doors between the stove and the fan location left open.

A spillage test as detailed in BS.5440 must be carried out after 5 minutes as follows - By holding a smoke match so that match head is approximately 3mm up inside the lower edge of the draught diverter (see Fig. 21). Spillage is indicated by smoke being displaced outwards from the draught diverter. If in doubt repeat after a further 10 minutes.

If spillage is detected the chimney may be faulty. The fault must be corrected before leaving the stove installed,

If the fault cannot be corrected turn off and disconnect the gas supply to the stove and seek expert advice.

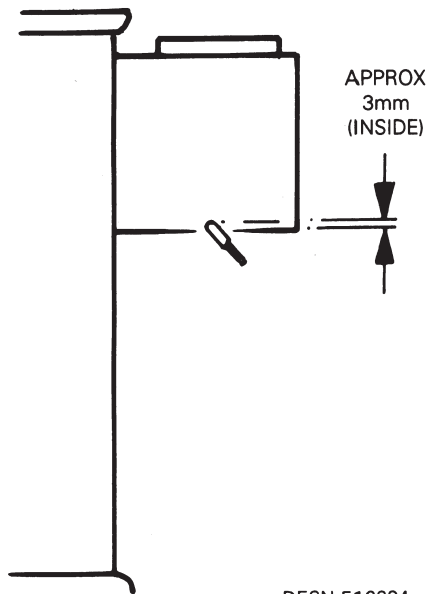

FIG. 21

DESN 510294

## INSTRUCT USER

Hand over all the instructions to the user and explain how to light and operate the appliance.

Impress upon the user that coals must be located in accordance with the instructions and that the appliance **MUST NOT** be operated with the glass panel in the door cracked or broken. The appliance should be serviced at regular intervals by a competent person to ensure safe operation.

Point out the removable warning labels which the customer **MUST** remove and read.

Advise the user that any smell emitted from the stove on initial lighting will quickly clear away with use.

The door tool must be stored in a safe place out of the reach of children

# SERVICING AND REPLACEMENT PARTS

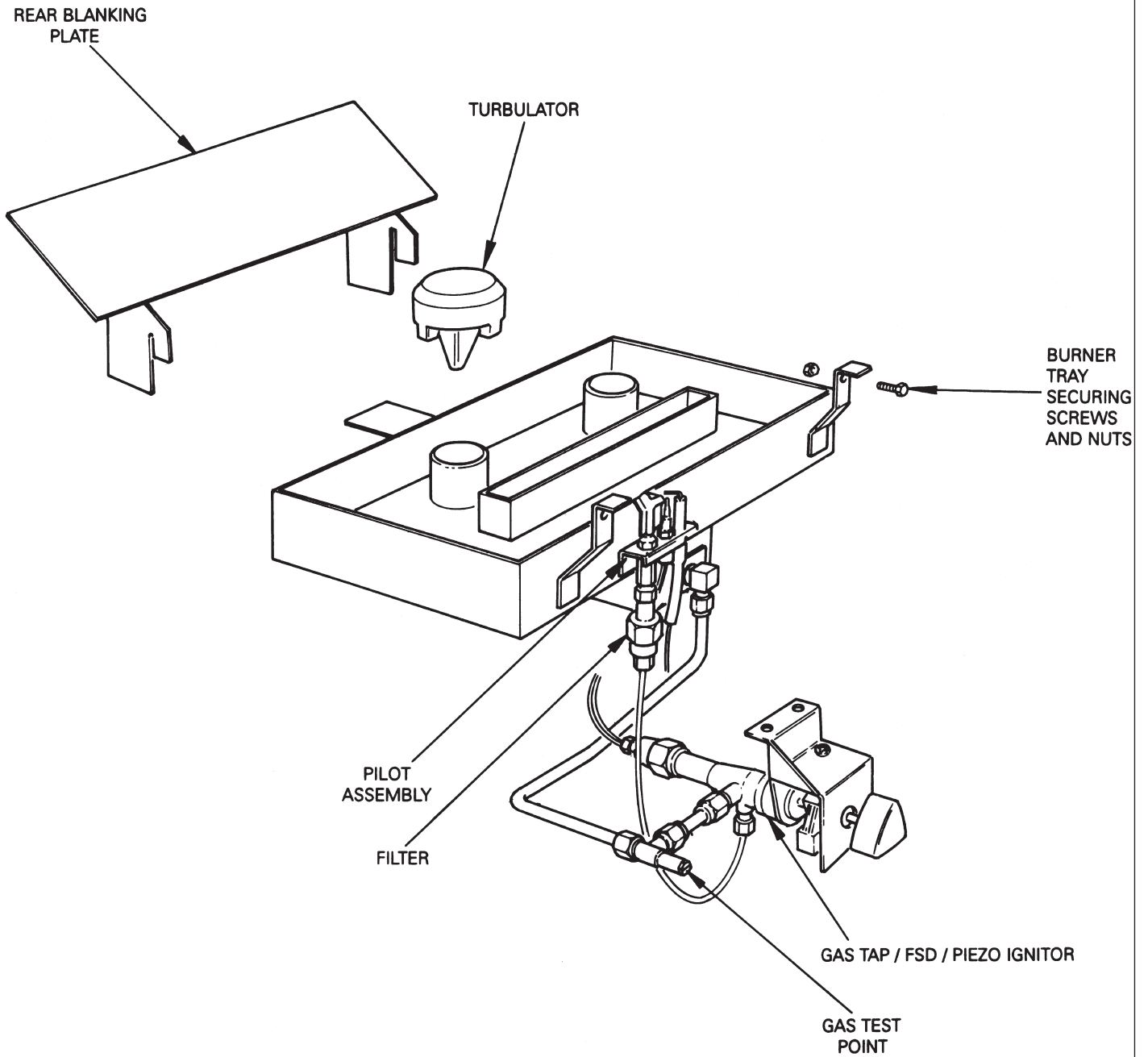

FIG. 22

DESN 510941

## SERVICING

It is recommended that the stove is inspected/serviced annually by a competent person (e.g. A Corgi Registered Installer).

It is recommended that the flue is checked for debris.

After any servicing **ALWAYS** check for gas soundness, and carry out a spillage test as detailed in the section 'CHECK FOR CLEARANCE OF PRODUCTS OF COMBUSTION'.

RE-ASSEMBLE PARTS IN REVERSE ORDER.

## SERVICING PROCEDURE

Ensure that the stove is cold.

Isolate the gas supply to the stove.

Hands should be washed after handling coals (If gloves are not used).

Open the door of the stove (using the tool supplied).

Carefully remove all coals from the fire and inspect for Damage/Breakage. Clean any excessive soot from the coals with a soft brush.

A VACUUM CLEANER MUST NOT BE USED, as this could remove the clay aggregate.

**IMPORTANT:** Carefully replace the coals as described in the section 'LAYING THE FUEL BED'.

## REPLACEMENT OF PARTS

Ensure the stove is cold.

Isolate the gas supply to the stove.

On completion ALWAYS check for gas soundness.

Hands should be washed after handling coals (if gloves are not used).

Open the door of the stove (Using the tool supplied).

Disconnect gas supply to Control Valve.

Remove coals, turbulators and blanking plate (See Fig. 22).

Remove the Burner Assembly, Tray Location and Securing Screws and nuts (See Fig. 22).

Carefully lift out the burner assembly tray and retain the clay aggregate. If necessary top up the tray with clay aggregate during re-assembly as described in 'LAYING THE FUEL BED'.

The following components can now be replaced as follows:

### Gas Tap/FSD/Piezo Ignitor

Note: The Piezo Ignitor is an integral part of the above item and is not available as a separate item.

Disconnect the thermocouple, the injector and pilot feed pipes at the Gas Tap/FSD/Piezo Ignitor.

Disconnect the ignition lead at the tap.

Pull off the control knob and remove the Gas Tap/FSD/Piezo Ignitor (2 screws). (See Fig. 22).

Fit replacement Gas Tap/FSD/Piezo Ignitor and re-assemble in reverse order, carefully replace the coals as described in 'LAYING THE FUEL BED'.

CHECK THE BURNER PRESSURE AS DESCRIBED IN '**TO LIGHT THE STOVE**'.

### Main Burner Injector

Disconnect feed pipe at the main injector and Gas Tap/FSD/Piezo Ignitor as detailed above. Remove injector.

Fit replacement injector and re-assemble in reverse order, carefully replace the coals as described in 'LAYING THE FUEL BED'.

### Pilot Assembly

Disconnect the feed pipe at the pilot assembly.

Disconnect the thermocouple connection at the control valve and pull off the ignition lead from the electrode.

Remove pilot filter.

Remove pilot assembly (one nut).

Fit replacement pilot assembly, and re-assemble in reverse order.

**NOTE:** Ensure that the insulation sleeving is pushed back over the end of the electrode during re-assembly.

Carefully replace the coals as described in 'LAYING THE FUEL BED'.

# FAULT FINDING CHART

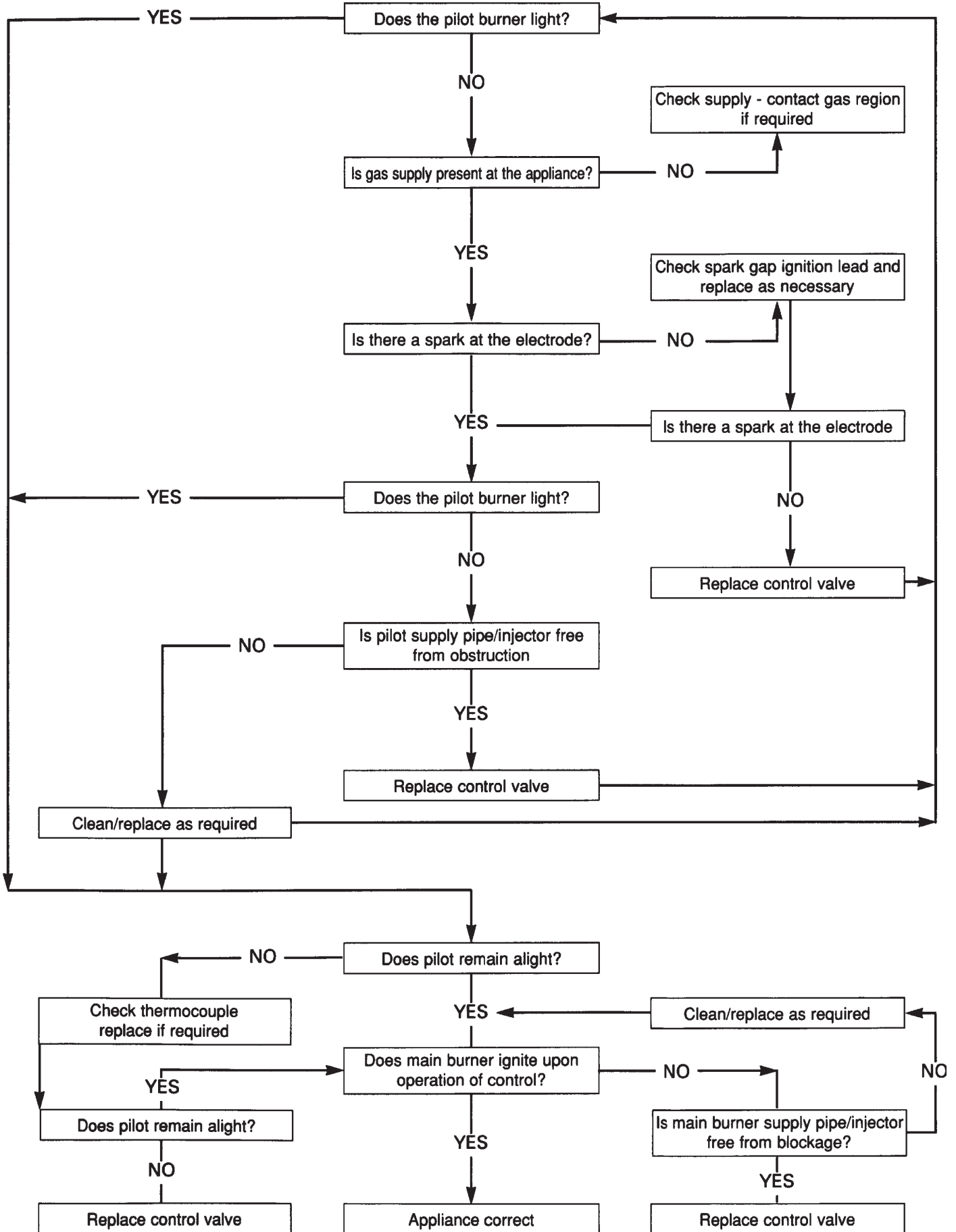

# SPARE PARTS

COALS PACK CONTAINING:-

BLACK, 9 SMALL



BLACK, 14 LARGE

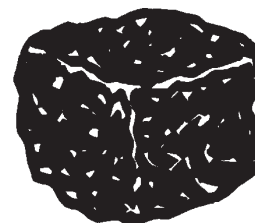

DESN 510888

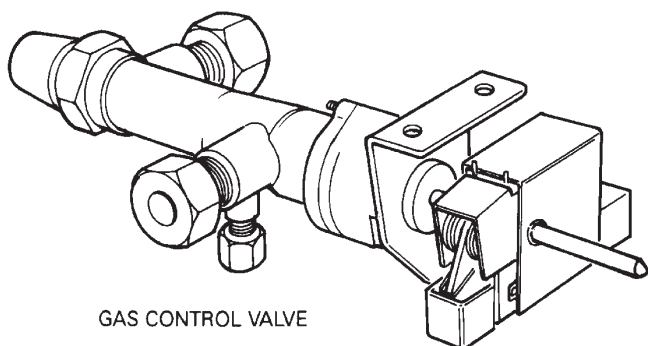

GAS CONTROL VALVE



CONTROL KNOB

DESN 510726

PILOT ASSEMBLY

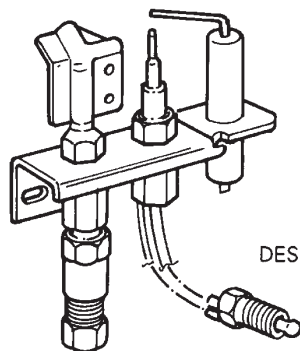

DESN 510623

BURNER INJECTOR

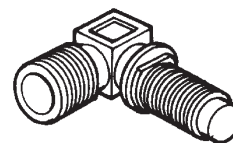

DESN 510727

## SHORT LIST OF SPARE PARTS

The following Spare Parts are available from your Distributor:

DESCRIPTION	MAKERS PART NUMBER
1. Gas Tap/FSD/Piezo Ignitor - PROPANE	HG4M 414059
2. Pilot Assembly - PROPANE	FG4M 420335
3. Burner Injector - PROPANE	FG4M 420110
4. Control Knob	HG4M 999413
5. Coals Pack	FG4M 420661
6. Aggregate Pack	TCLY 414047
7. Turbulator	FG4M 420450
8. Door Tool	HS1M 93003

THEY SHOULD BE FITTED ONLY BY A COMPETENT PERSON (e.g. A CORGI Registered Installer).



With Aga-Rayburn's policy of continuous product improvement, the Company reserves the right to change specifications and make modifications to the appliance described and illustrated at any time.

---

**COALBROOKDALE**

Manufactured By  
Aga-Rayburn  
Station Road, Ketley, Telford, Shropshire, TF1 5AQ

**For further advice or information contact  
your local distributor/stockist**

Telephone (01952) 642000 Fax (01952) 641961

# THE COALBROOKDALE GS2i

## Users Instructions

### Propane Gas Model

Ⓒ Cat I<sub>3p</sub> (G31) For use in GB and IE at a supply pressure of 37mbar

#### Consumer Protection Act 1987

As manufacturers and suppliers of cooking and heating products, in compliance with Section 10 of the Consumer Protection Act 1987, we take every care to ensure, as far as is reasonably practicable, that these products are so designed and constructed as to meet the general safety requirement when properly used and installed. To this end, our products are thoroughly tested and examined before despatch.

**IMPORTANT NOTICE:** Any alteration that is not approved by Aga-Rayburn could invalidate the approval of the appliance, operation of the warranty and could also affect your statutory rights.

#### Control of Substances - Health & Safety Important

This appliance may contain some of the materials that are indicated. It is the Users/Installers responsibility to ensure that the necessary

personal protective clothing is worn when handling where applicable, the pertinent parts that contain any of the listed materials that could be interpreted as being injurious to health and safety, see below for information.

**Firebricks, Fuel beds, Artificial Fuels** - when handling use disposable gloves.

**Fire cement** - when handling use disposable gloves.

**Glues and Sealants** - exercise caution - if these are still in liquid form use face mask and disposable gloves.

**Glass Yarn, Mineral Wool, Insulation Pads, Ceramic Fibre, Kerosene/Gas Oil** - may be harmful if inhaled. May be irritating to skin, eyes, nose and throat. When handling avoid contact with skin or eyes. Use disposable gloves, face-masks and eye protection. After handling wash hands and other exposed parts. When disposing of the product, reduce dust with water spray, ensure that parts are securely wrapped.

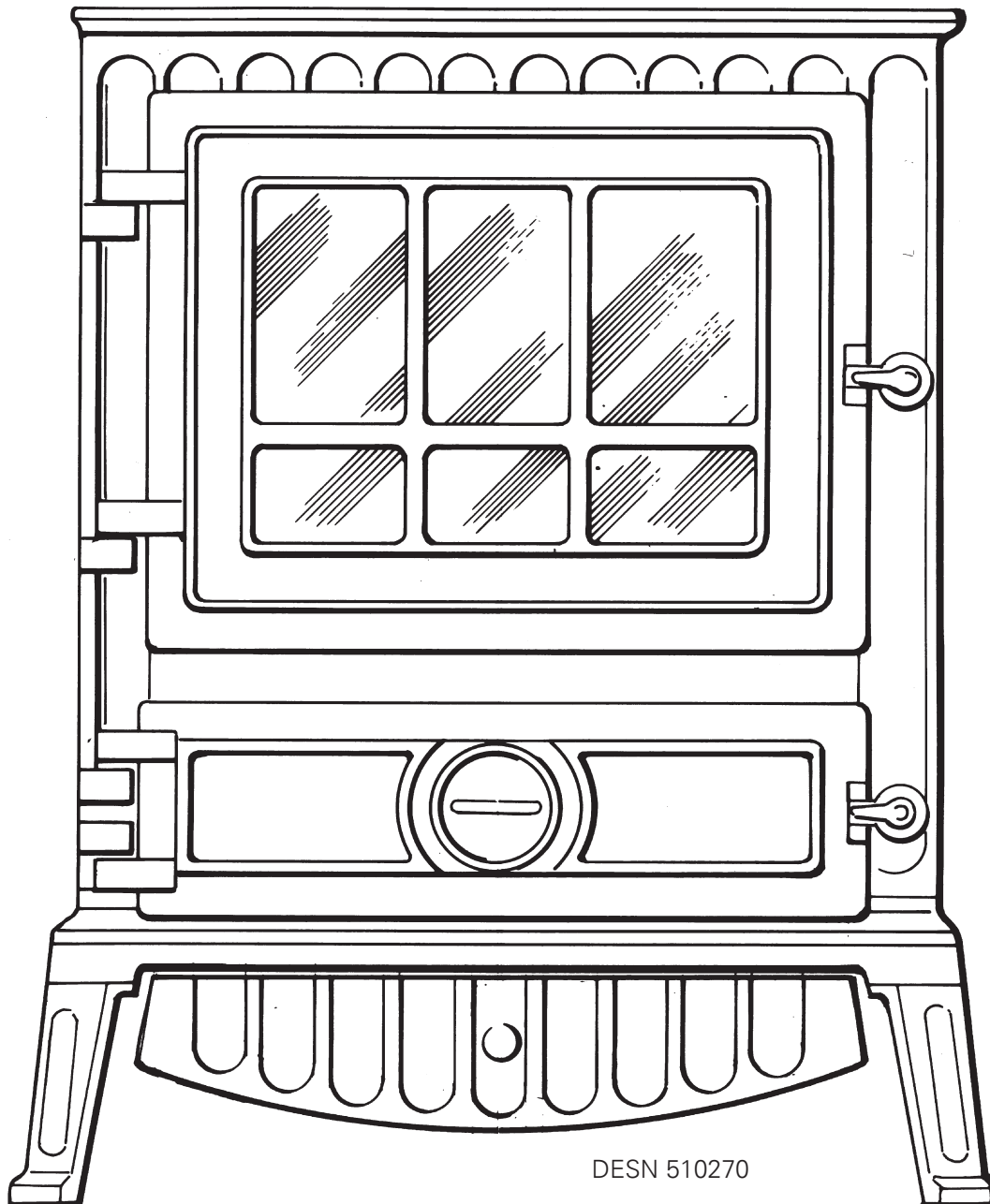

DESN 510270

WP 2/95 EOPI 510923

Dear Customer

Your gas stove is for use on **propane gas only** and **must not** be used on any other gas. It **must be** installed by a competent person (e.g A CORGI Registered Installer) in accordance with the Installation Instructions and operated in accordance with these users instructions if so it should provide many years of safe and efficient operation.

Please complete the separate guarantee card and return it to us within 28 days of purchase. This will enable us to record the details of your purchase and keep you advised of any future developments.

We thank you for purchasing our product and trust it will provide many years of excellent service.

## GUARANTEE

The components of this appliance are guaranteed for one year. We agree to repair free of charge or, at our option replace the appliance or parts thereof which may prove to be defective within one year of purchase.

Please retain your purchase receipt. Our Service Engineer will need to see this in the event of a claim under warranty.

## IMPORTANT NOTES

Your Coalbrookdale GS2i is a propane gas stove.

Due to the newness, the stove may give off a slight smell for a short period after commissioning. This is quite normal and will disappear after a few hours of operation, open doors and windows, if required.

The installation of the stove must be carried out by a competent person (e.g. CORGI Registered Installer), in accordance with the installation instructions and the current Gas Safety (Installation and Use) Regulations 1994. Failure to install the appliance correctly could lead to prosecution.

Before installation of your stove your installer should check that the chimney is sound, free from obstruction and clean. If a brick chimney is to be used for the gas stove it **MUST** be swept prior to the installation.

The hearth under the stove should never be covered with combustible flooring or material. Do not obstruct the space beneath the stove.

**WARNING: DO NOT OPERATE THE STOVE WITH THE GLASS PANEL IN THE DOOR CRACKED OR BROKEN. THE DOOR MUST ALWAYS BE CLOSED USING THE TOOL PROVIDED.**

The Coalbrookdale GS2i has been designed similar to a solid fuel stove to relevant safety standards, but during use, many parts of the appliance can become **HOT** to touch. We recommend that you provide and secure a fireguard complying with BS.6539 when the room is used by elderly, infirm or young persons.

Any alteration after the initial commissioning must be in accordance with the requirements of the Installation and Servicing Instructions. Clarification of combustible material clearance, hearth dimensions, shelf heights and fluing requirements are detailed in the section 'Location' and the 'flue'.

The chimney should be checked on a regular basis to ensure continued clearance of combustion products and that there is no accumulation of debris or soot etc. It is recommended that the appliance is inspected/serviced annually by a competent person (e.g A CORGI Registered Installer).

To ensure safe operation of the appliance the room containing the stove must have purpose provided ventilation such as an air brick or door grill. This serves to replace the air used in the combustion process and it is particularly important that the vent remains free from obstruction at all times. Therefore you should make periodic checks to ensure that the ventilation is free from obstructions.

Combustible furniture or material **MUST NOT** be placed closer than 1m in front of this stove.

It is **NOT** recommended to have any material, such as curtains, above the appliance or to within 1m at the sides.

Clothing or other flammable material should **NOT** be placed on the stove.

Blown vinyl or similar materials which have a raised pattern, are easily affected by heat and may scorch or discolour if placed too close to a heating appliance. Please bear this in mind when installing the stove and when re-decorating.

The door tool must be stored in a safe place out of the reach of children.

This appliance should under **NO** circumstances be utilised for solid fuel.

## OPERATION OF THE STOVE

The gas to the stove is controlled by a pilot light, control knob and a safety feature called a flame supervision device.

To gain access to the gas control knob, remove the control cover. (Fig. 1).

The tap knob bezel is marked with position for OFF (●). PILOT (✂) and a graduated section for minimum and maximum gas rate (Fig. 2).

The stove is fitted with a piezo spark ignitor.

**Note: If the main burner or pilot are extinguished for any reason, DO NOT attempt to re-light the pilot for three minutes.**

## TO LIGHT THE PILOT

Remove the control cover. Ensure that the glass door is closed and locked and that the control knob is in the OFF (●) position (Fig. 2).

Fully depress the control knob and turn anti-clockwise (keeping the knob fully depressed) until the pilot position (✂) is reached (Fig. 2). If the pilot has not lit repeat operation.

Once the pilot is lit continue to hold in the control knob for a further 10-15 seconds to establish the pilot. When the control knob is released the pilot should remain alight. If the pilot fails to remain alight repeat procedure but hold the knob in longer to allow the pilot to establish.

If required the pilot may be lit by a long spill or taper as follows:

Open the door of the stove (using the tool supplied) (See Fig. 3).

Apply a lighted spill or taper to the pilot (See Fig. 4) positioned at the front LH side of the burner tray.

Fully depress the control knob and turn anti-clockwise (keeping the control knob fully depressed) until the pilot position ( ) has been reached and the pilot should light.

Once the pilot is lit remove the long spill or taper, continue to hold the control knob for 10 to 15 seconds to establish the pilot. When the knob is released, the pilot should remain alight. If the pilot fails to remain alight, repeat the procedure but hold the knob in longer.

**When pilot is established close the door (using the tool supplied).**

**NOTE! The lower door on the stove is to ease service ability.**

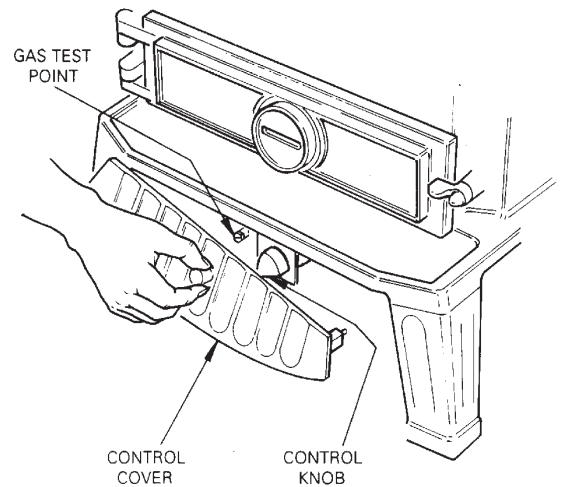

FIG. 1

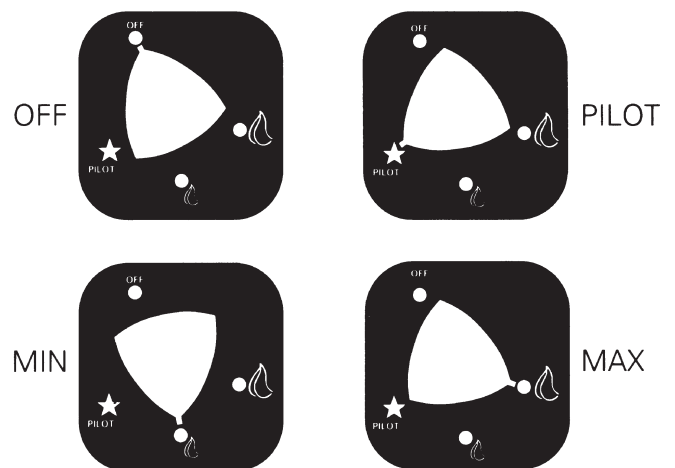

FIG. 2

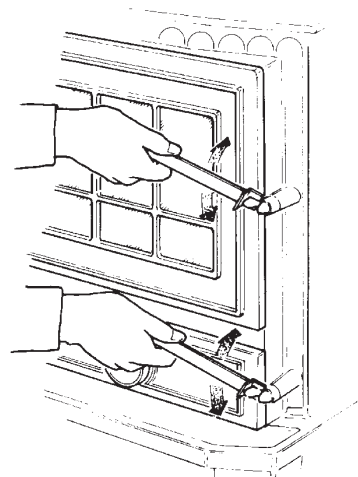

FIG. 3

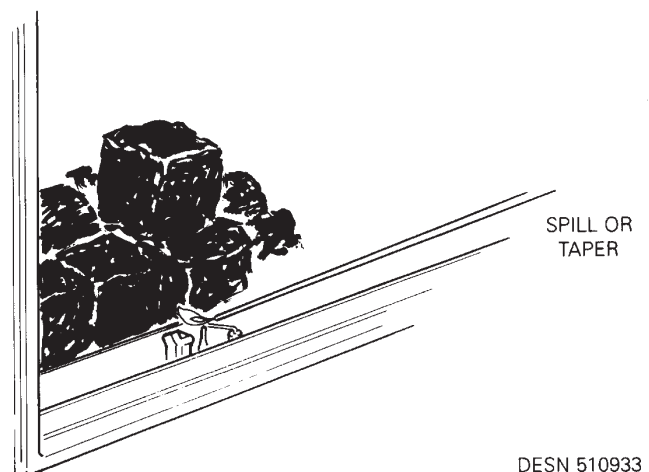

FIG. 4

## TO LIGHT THE STOVE

If the pilot is not already alight, light the pilot as described. Slightly depress and turn the control knob anti-clockwise from the pilot position (★) (see Fig. 5). The fire will ignite.

Adjust the heat output as required by turning the control knob clockwise towards the minimum position (⦿) (See Fig. 6).

To ensure correct operation of the stove it is recommended that it is NOT operated below the minimum setting.

Replace the control cover.

## TO TURN THE STOVE OFF

Turn the gas control knob to the minimum gas rate position (⦿) (Fig. 7), slightly depress the knob and continue turning to the pilot position (★) (Fig. 8). The fire will go out, and the pilot will remain lit and may be left on permanently.

## TO TURN THE STOVE AND PILOT OFF

Turn the stove off as described. Depress the control knob, turn to the off position (●) (Fig. 9) and the pilot will go out.

FIG. 5

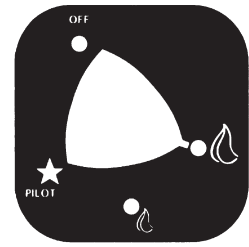

FIG. 6

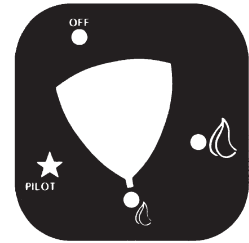

FIG. 7

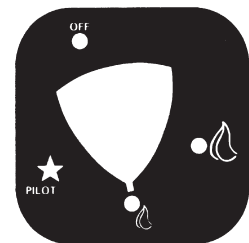

FIG. 8

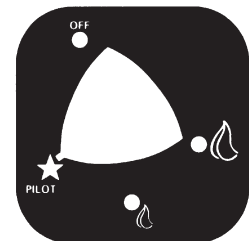
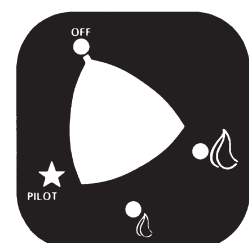

FIG. 9



## CLEANING

Cleaning should be carried out when the stove is turned OFF and is cold.

The exterior of the stove can be cleaned with a vacuum cleaner, or dusted with a soft brush, either dry or moistened by drawing the bristles over a damp cloth.

A cloth is not recommended as it can leave fibres behind.

The flame effect of the stove may deposit some soot on the coals or back of the stove. This is quite normal and need not be cleaned off but if desired can be removed by careful use of a brush.

**WARNING:** DO NOT USE A VACUUM CLEANER.

Remove the coals for cleaning and replace as described below.

## REMOVING AND REPLACING COALS

**Ensure that the stove and pilot are turned OFF and that the stove is cold.**

Open the door of the stove (Using the tool supplied) (Fig. 3).

In time, due to expansion and contraction, the 'coals' may settle. The settlement of the 'coals' may cause minor abrasions and expose some white spots. These white spots usually add realism to the stove when in operation.

UNDER NO CIRCUMSTANCES TRY TO RE-COLOUR THE COALS WITH PAINT.

If the settlement of the 'coals' has produced an unsatisfactory flame pattern, or if the 'coals' need to be replaced, remove existing 'coals' and replace as follows.

If the clay aggregate has settled 'top up' as necessary (Fig. 11) and ensure that the ceramic turbulators (Fig. 10) are correctly positioned prior to re-laying the 'coals'.

### Positioning the Coals

Carefully place the coals on the coal bed as illustrated in Figs. 12, 13, 14 and 15.

Close the door and lock (using the tool supplied).

**WARNING:** USE ONLY THE SIMULATED COALS AND AGGREGATE SUPPLIED WITH THE APPLIANCE TO BUILD THE BED UNDER NO CIRCUMSTANCES USE EXTRA COALS OR PUT ANY OTHER MATERIAL ON THE FUEL BED.

DO NOT OPERATE THE STOVE WITH THE DOOR OPEN OR IF THE GLASS PANEL IN THE DOOR IS CRACKED OR BROKEN.

Hands should be washed after handling coals. (If gloves are not used).

# LAYING THE FUEL BED

LOCATE THE REAR BLANKING PLATE AS SHOWN.

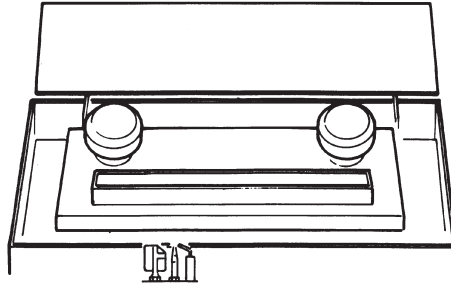

FIG. 10

DESN 510935

LOCATE THE TURBULATORS AS SHOWN.  
POUR THE CLAY AGGREGATE SUPPLIED INTO THE TRAY UNTIL IT IS FLUSH WITH THE TOP OF THE BURNER TRAY.

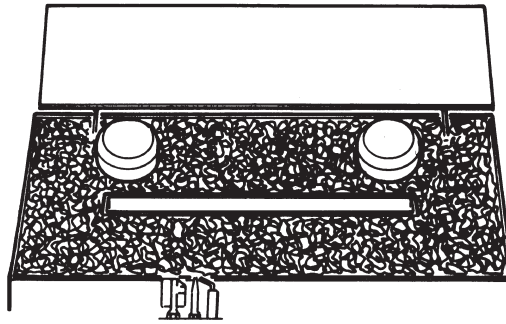

FIG. 11



DESN 510936

LOCATE 2 COALS ON TOP OF THE TURBULATORS AS SHOWN.

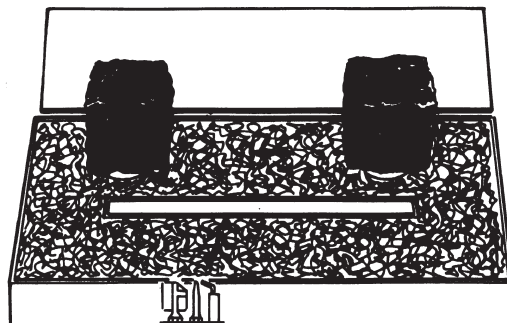

FIG. 12



DESN 510937

PLACE 4 COALS TO THE REAR OF THE BURNER TRAY AS SHOWN.

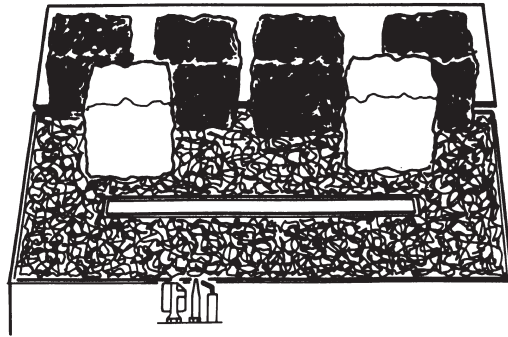

FIG. 13



DESN 510938 'A'

PLACE 3 COALS ONTO THE BURNER TRAY AS SHOWN.

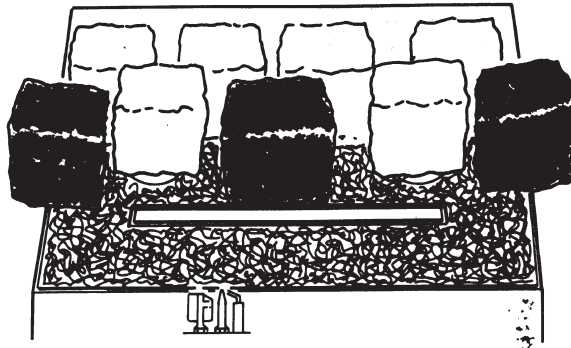

FIG. 14



DESN 510939 'A'

PLACE THE REMAINING 6 COALS ONTO THE BURNER TRAY AS SHOWN.

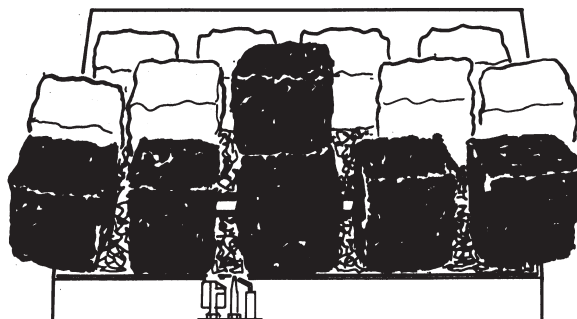

FIG. 15



DESN 510940 'A'



## MAINTENANCE

If you require any of the user replacement items listed below or if you have any difficulty with the fire, consult your original supplier quoting the stove's name Coalbrookdale GS2i - Serial No - GC No. (if applicable) (found on the data plate on the inside of the service door).

Serial No.

The appliance should be serviced annually by a competent person (e.g CORGI Registered Installer).

## HEAT OUTPUT (GROSS)

### Maximum Setting

kW 3.96

### Minimum Setting

2.2 kW

## REPLACEMENT ITEMS

These are available from your supplier, and such items which can be changed are:

ITEM	MAKERS PART NUMBER
Control Knob	HG4M 999413
Coals Pack	FG4M 420661
Turbulator	FG4M 420450
Aggregate Pack	TCLY 414047
Door Tool	HS1M 93003

With Aga-Rayburn's policy of continuous product improvement, the Company reserves the right to change specifications and make modifications to the appliance described and illustrated at any time.

**COALBROOKDALE**

Manufactured By  
Aga-Rayburn  
Station Road, Ketley, Telford, Shropshire, TF1 5AQ

Telephone (01952) 642000 Fax (01952) 641961

**For further advice or information contact  
your local distributor/stockist**