



# Pre-site Installation Instructions for Aga Electric Cooker Models Electric C Electric E

(€) FOR USE IN GB & IE

## Electric Cookers

### PLEASE READ THESE INSTRUCTIONS BEFORE INSTALLING YOUR AGA

#### Consumer Protection

As responsible manufacturers we take care to make sure that our products are designed and constructed to meet the required safety standards when properly installed and used.

#### IMPORTANT NOTICE: PLEASE READ THE ACCOMPANYING WARRANTY.

Any alteration that is not approved by Aga, could invalidate the approval of the appliance, the warranty and could also infringe the current issue of the statutory requirements.

#### Important:

This appliance could contain any of the materials that are indicated below. It is the Users/Installers responsibility to ensure that the necessary personal protective clothing is worn when handling, where

applicable, the pertinent parts that contain any of the listed materials that could be interpreted as being injurious to health and safety, see below for information.

**Firebricks, Fuel beds, Artificial Fuel** – when handling use disposable gloves.

**Fire cement** – when handling use disposable gloves.

**Glues and sealants** – exercise caution – if these are still in liquid form use face mask and disposable gloves.

**Glass Yarn, Mineral Wool, Insulation Pads, Ceramic Fibre**, – may be harmful if inhaled, may be irritating to skin, eyes, nose and throat. When handling avoid inhaling and contact with skin or eyes. Use disposable gloves, face masks and eye protection. After handling wash hands and other exposed parts. When disposing of the product reduce dust with water spray, ensure that parts are securely wrapped.

The responsibilities and European safety standards required from the appliance manufacturers and the installers must be consistently achieved and maintained in order to fulfil our joint obligations. The criteria for such safety standards are set and such standards are the minimum permissible. The manufacturer accepts overall responsibility and ensures that the finished unassembled appliance has been monitored throughout its manufacture which includes electrical testing and checking where applicable.

**NOTE: THE SITE ERECTION, INSTALLATION AND ELECTRICAL TESTING OF THE APPLIANCE BECOMES THE RESPONSIBILITY OF THE INSTALLER. THIS IS WHERE SAFETY STANDARDS ARE PARAMOUNT, AND THE FOLLOWING BASIC INSTRUCTIONS ARE PROVIDED TO ASSIST INSTALLERS FROM THE MOMENT OF CUSTOMER ENQUIRY.**

### PRELIMINARY SITE INSPECTION

No cooker order must be accepted without first carrying out a preliminary site inspection to confirm the following:-

1. The floor is capable of supporting the weight of the cooker.

2 Oven Cooker	4 Oven Cooker
708kg	842kg

and is constructed of non-combustible material for at least 50mm of its thickness, is level in all directions and does not form a fire hazard.

If the floor is solid and constructed of combustible material, a non-combustible hearth must be provided (the size of the cooker base) which must be at least 50mm thick over it. General dimensions of the cooker are shown in Fig. 1.

2. Houses constructed of combustible materials (such as all-timber) require special wall heat protection features, and these are shown in Fig. 2 proposals 1 and 2.

Non-combustible walls behind a cooker must be at least 25mm thick.

In addition oven vent piping must be insulated with high temperature film glass sleeving, supplied upon application.

3. The appliance oven venting pipe can be achieved, up to a

maximum length of 6m, through an outside wall or unused flue etc. Great care must be taken in all-timber houses.

To ensure the oven venting discharge pipe is adequately insulated from timber contact. A high temperature pipe sleeving should be fitted to the discharge pipe where such conditions occur, and are likely to be in timber contact.

The oven vent fan performance is directly proportional to the length of the vent pipe (see section Oven Venting Systems). A current regulator mounted on the p.c.b. must be individually set as recommended, to suit the length of the vent pipe installed.

Unorthodox venting problems must be referred back to Works.

4. A consultative discussion must take place with an authorised member of the Area Electricity Board to determine respective area of responsibilities and tariffs available.

The appliance is designed to utilise Cheap Rate periods of electricity. See Figs. 3a, 3b, 3c & 3d.

### ELECTRICAL SUPPLY

WARNING: THE APPLIANCE MUST BE EARTHED.

- i) Electrical installation of the power supply between the cooker and the meter, must be undertaken, directly or indirectly, by the installer utilising a qualified competent electrical contractors with installation conformance to current National and local regulations and good practice.
- ii) A suitable double-pole control unit with a minimum contact clearance of 3mm should be fitted adjacent to the appliance.
- iii) Technical Specification table

	1PH
VOLTAGE SUPPLY	230V - 50Hz
POWER	5.5kW
CURRENT AMPS	23.4A
TELE-SWITCHING	2AMP

### AGA ELECTRIC C

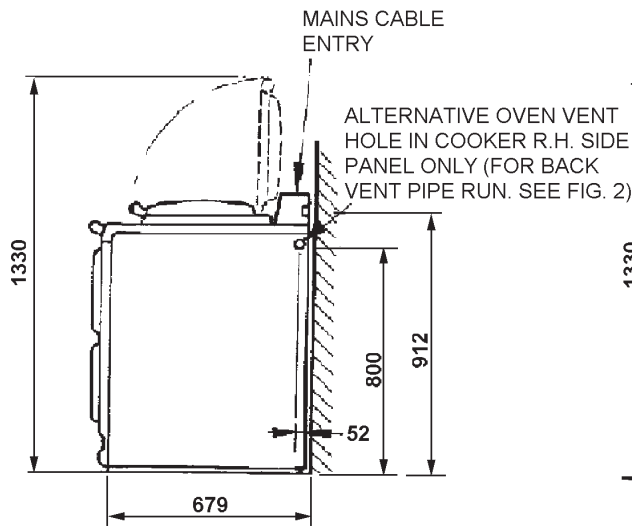

### AGA ELECTRIC E

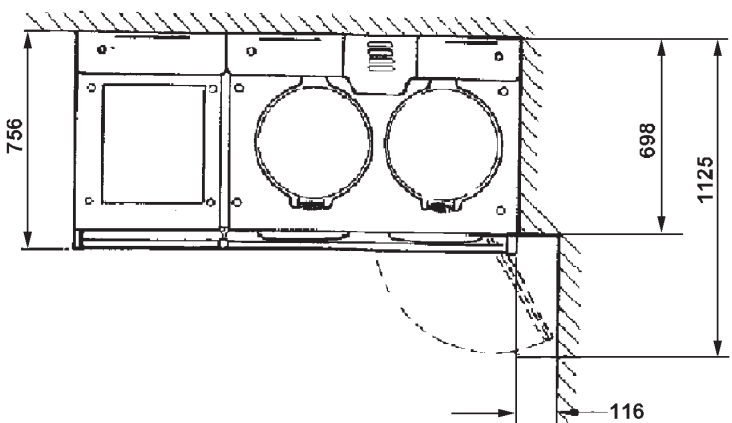
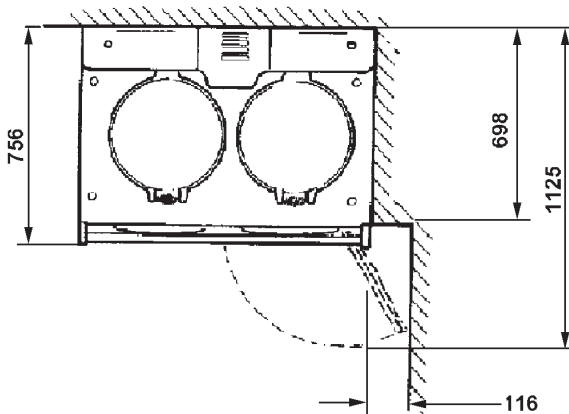
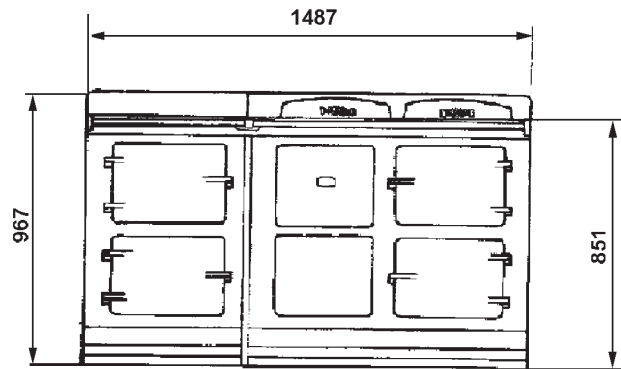
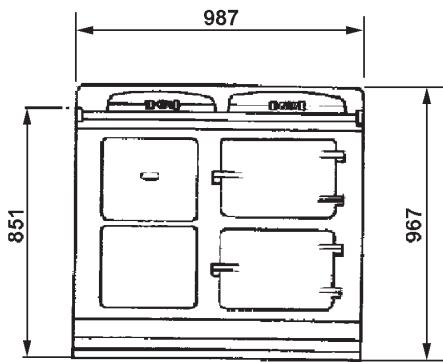
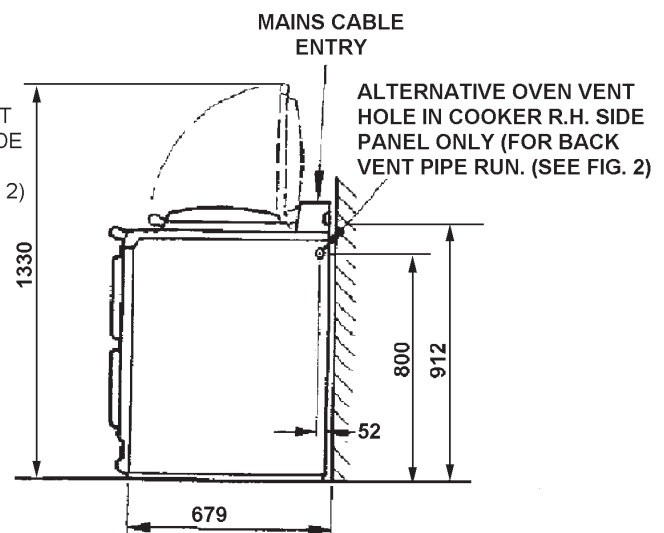

ALL DIMENSIONS IN MILLIMETRES

**SIDE CLEARANCES:** A 3mm gap is required each side between the cooker top plate and adjoining work surfaces that maybe fitted, this is to allow for the safe removal of the top plate should it be required at a later date.

Where cookers are fitted against side walls a 116mm clearance is required at the right hand side for oven doors access.

If the Aga is to be installed in a brick recess, then the minimum clearance should be increased by at least 10mm on either side, to allow for the walls not being square and also for the natural dimensional variations found in the castings.

Fig.1 General Dimensions Details

DESN 510310 'D'

**PROPOSAL 1 - LOCAL CONVERSION TO REPLACE WITH BRICK WALL**

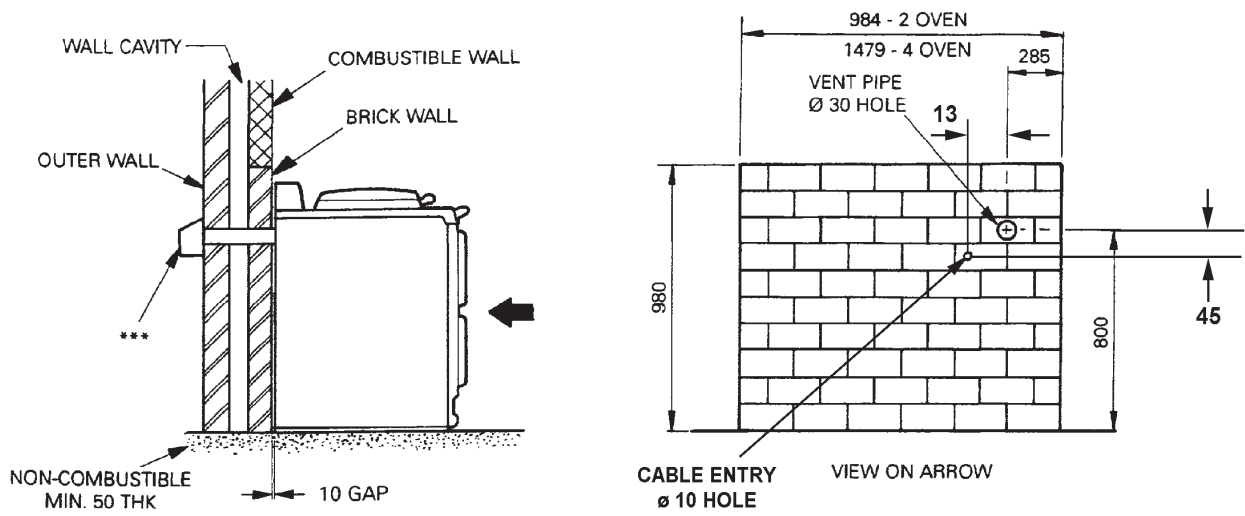

**PROPOSAL 2 - EXISTING COMBUSTIBLE WALL INSTALLATION**

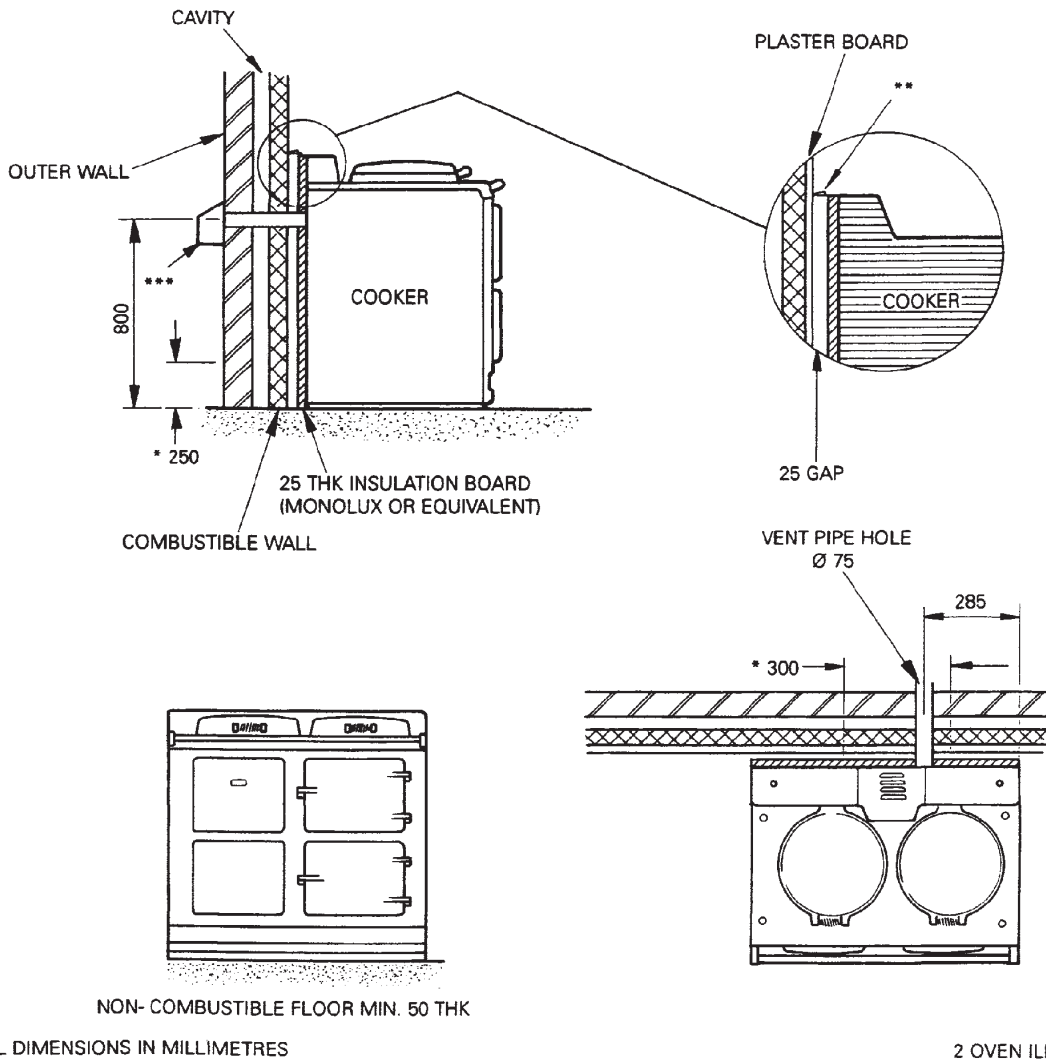

\* The 25mm air gap behind the cooker may be 'boxed in' around the edges but the minimum air gaps shown MUST be maintained  
 \*\* Alternatively, the top gap may be covered by a louvered plate but this MUST allow 7500mm<sup>2</sup> of free air to pass.  
 \*\*\* See Fig.7 for Vent Fan fixing details

Fig.2. Installation Proposals for Combustible Walls

# WIRING OPTION 1

If the cheap rate period is controlled by Signal Switching using a separate 2A circuit, not in the Power Circuit, the appliance is capable of maintaining a Core Temp of 375°C, (using peak electricity) even under prolonged cooking periods.

Both supplies require protection by installing strategically placed isolation switches no more than 2 metres from the Cooker.

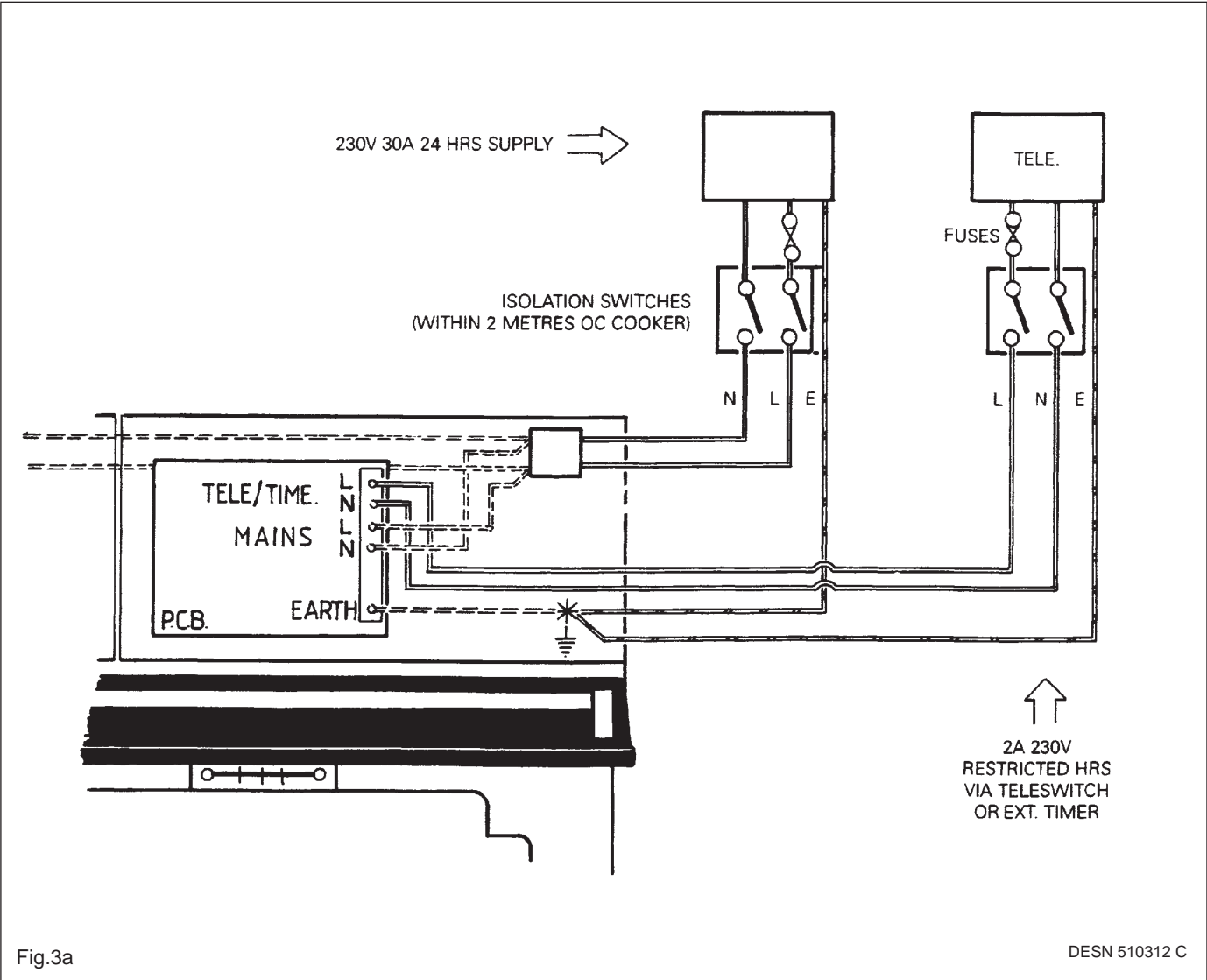

Fig.3a

DESN 510312 C

# WIRING OPTION 2

If the cheap rate period(s) is/are controlled by switching the Power Circuit, the appliance core (under prolonged cooking periods) may fall below 375°C and will only be charged up on next Tariff period.

In this case a separate 2A 230V 24hr circuit is required to maintain power to the P.C.B.

Both supplies require protection by installing strategically placed isolation switches no more than 2 metres from the Cooker.

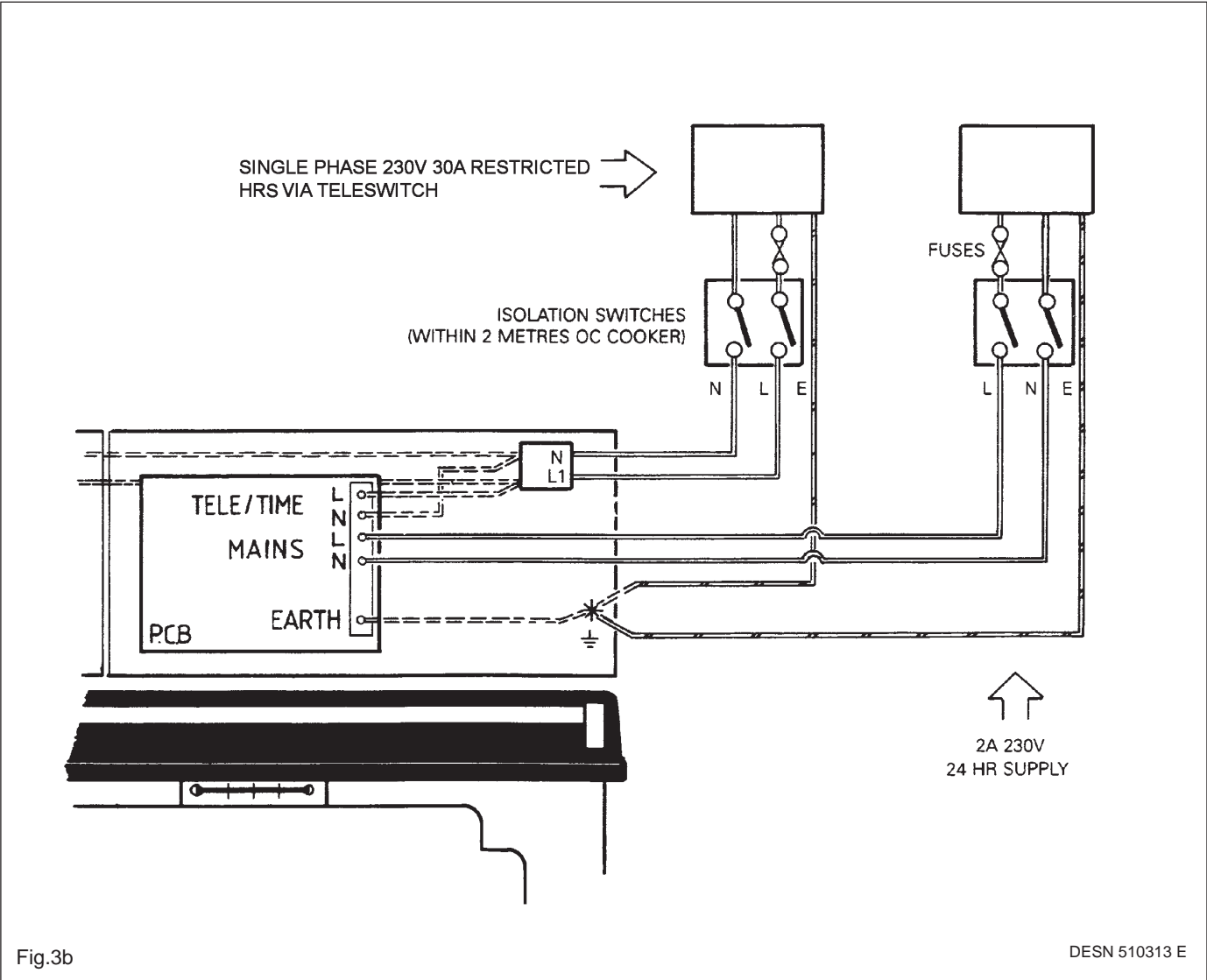

Fig.3b

DESN 510313 E

# WIRING OPTION 3-POWERED THRU CONTROLLER (EXTERNAL TIMER)

This Timer option allows flexibility regarding Charge times.

The Timer must include a Battery back-up.

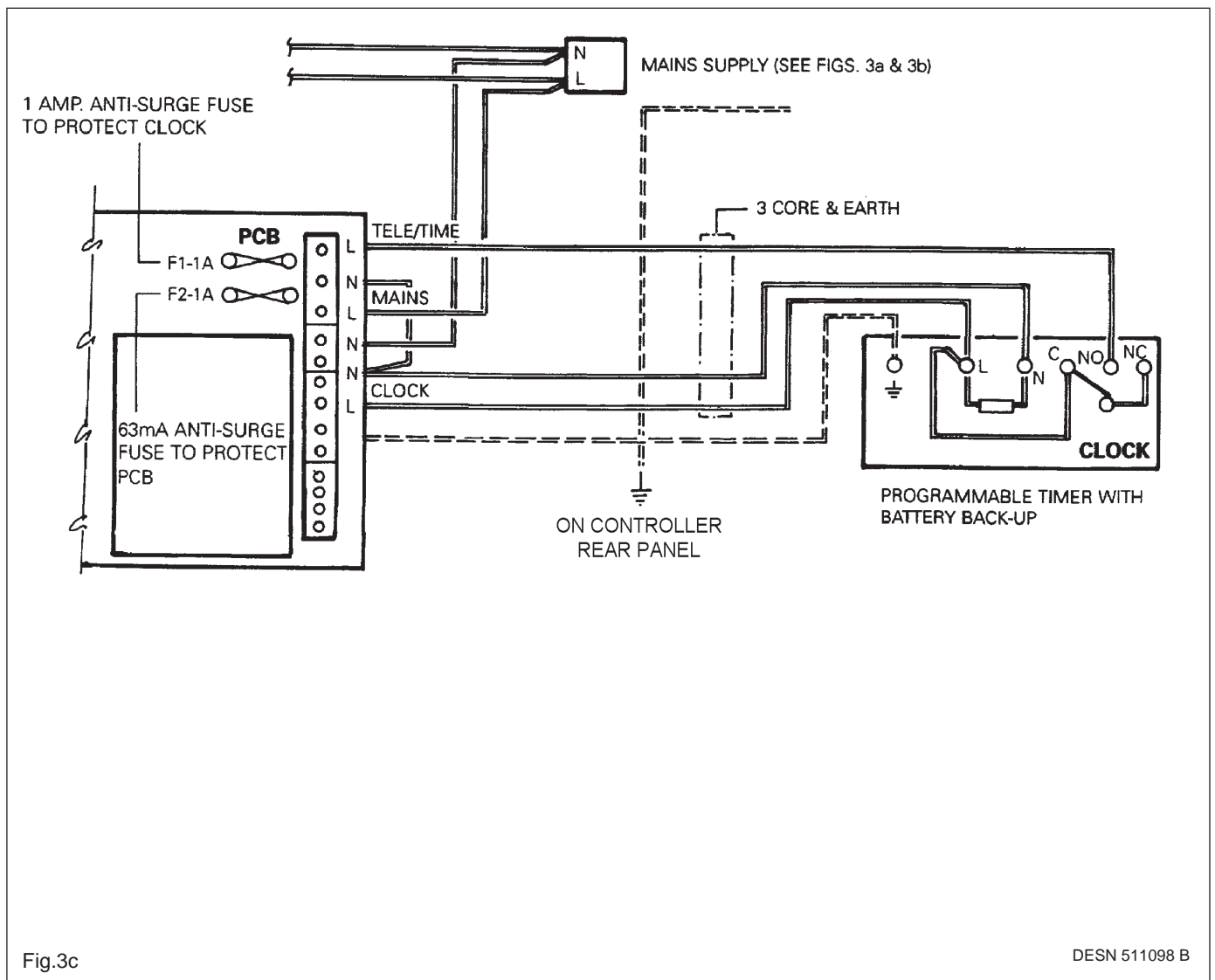

# WIRING OPTION 4-POWERED BY EXT. MAINS SUPPLY (EXTERNAL TIMER)

This Timer Option allows flexibility regarding Charge times.

The Timer must include a Battery back-up.

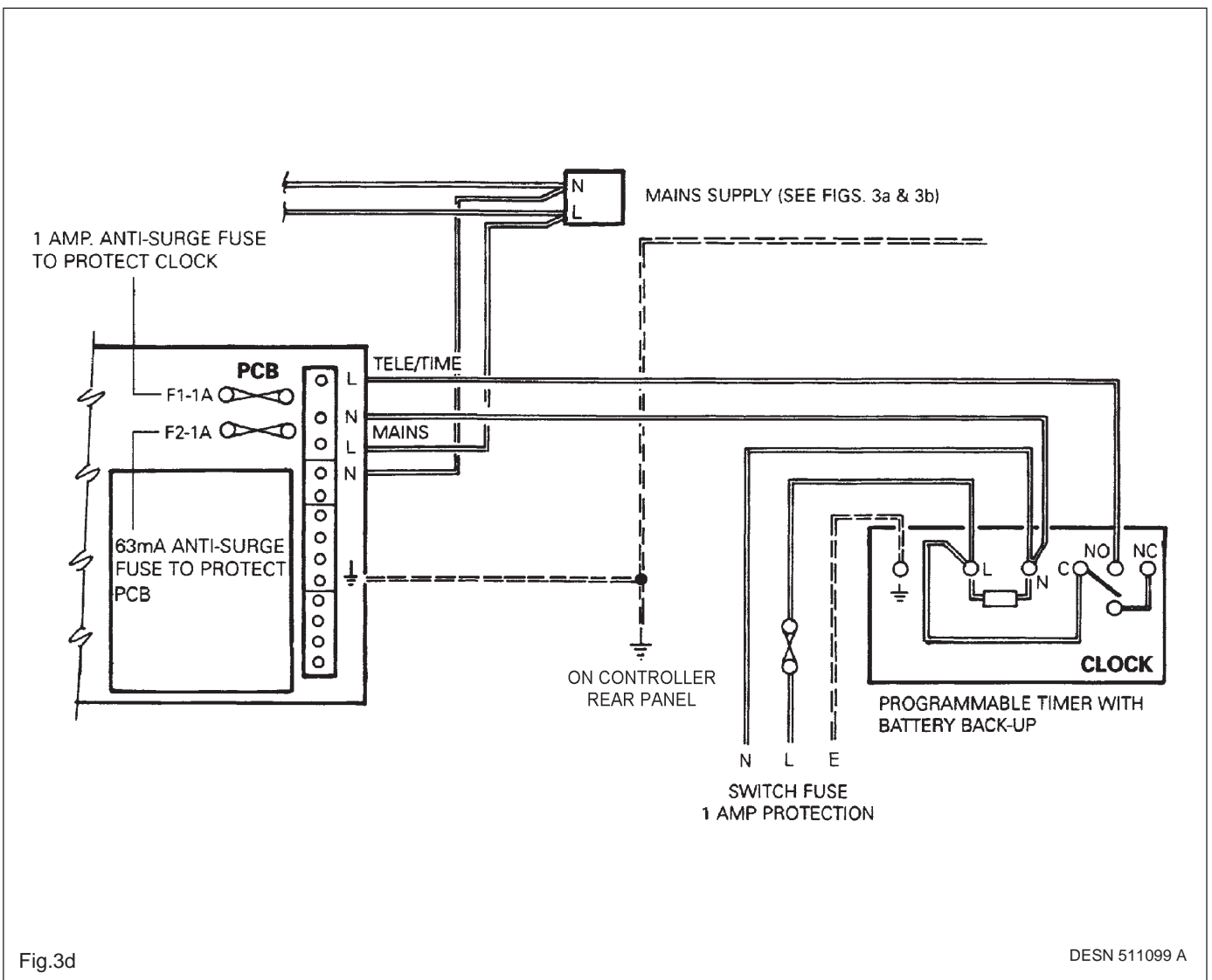

Fig.3d

DESN 511099 A

# OVEN VENTING SYSTEMS

See Figs. 4, 5, 6 & 7

Pre-site visiting will have determined where and how the layout of the oven vent pipework should be designed and installed. It is then necessary to check that the pipework design and the pipework resistance are within the parameters permissible.

## Setting The Vent Fan (Motor Speed)

Setting of the Motor Speed is carried out by adjusting the Voltage Regulator (VRI) on the controller PCB in conjunction with a voltmeter. (See Fig. 5).

**The max supply to the motor, as calculated in Fig. 4, should be limited to 20v (DC), for ideal operating condition.**

Calculating the voltage for the particular pipework layout is as follows:

1. Keep the pipe run as simple as possible - avoid bends.
2. 'Vertical risers' are not permitted.
3. Pipe run should be horizontal - slight downwards slope towards fan.

Minimum 12 volts for first metre of vent pipe run inclusive of 1 bend.

Each extra metre add 1 volt.

Each extra bend add 2 volts.

Maximum allowed 20 volts.

## Alternative Oven Venting Systems

Venting may be achieved directly into a Flue providing a stabiliser is fitted. See Fig. 6.

**NOTE: IN THE OVEN VENTING INSTALLATION, WHETHER FAN ASSISTED OR NATURAL FLUE, PROVISION MUST BE MADE FOR EASY 'RIFLING' OF THE PIPEWORK TO FACILITATE CLEANING.**



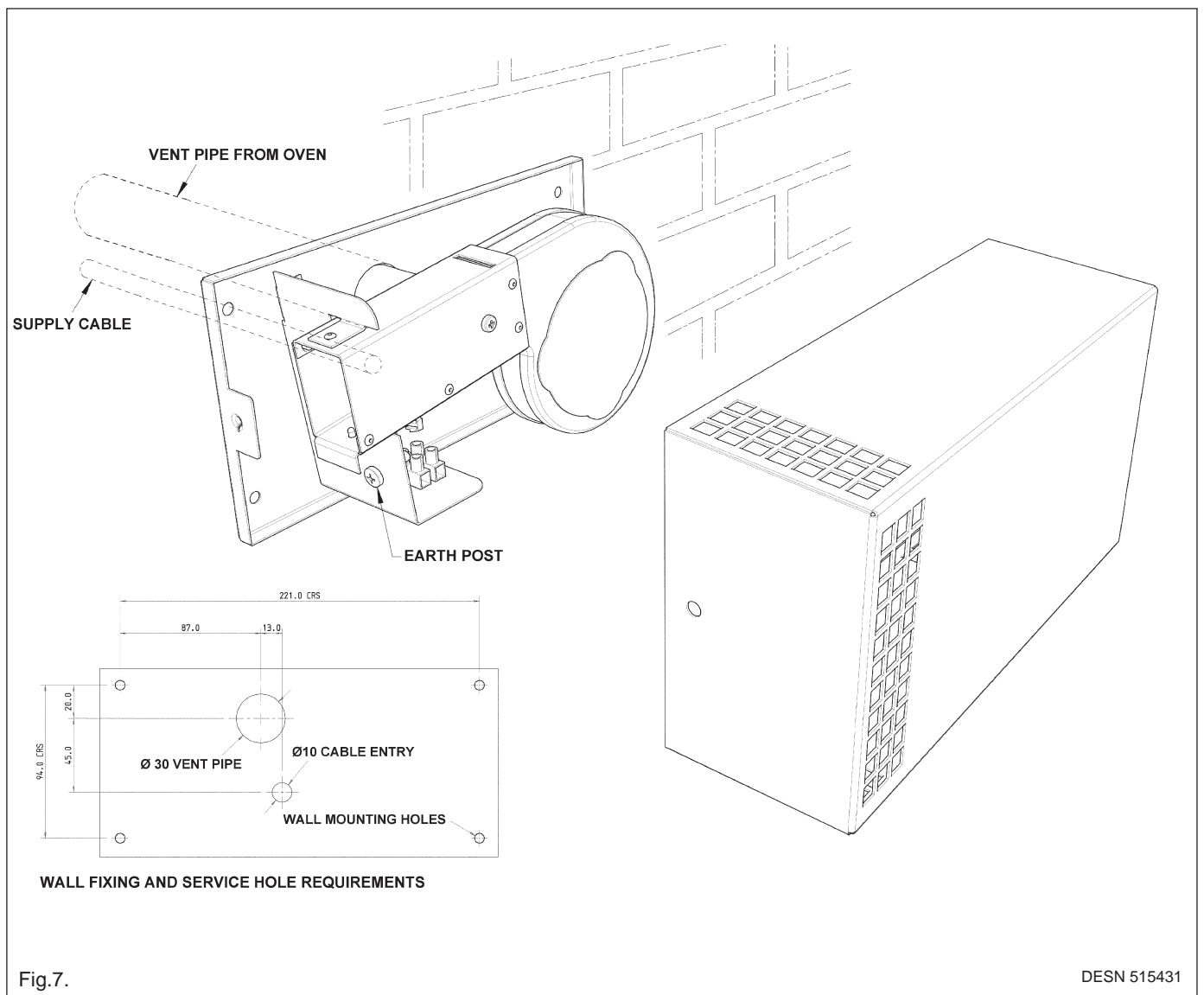
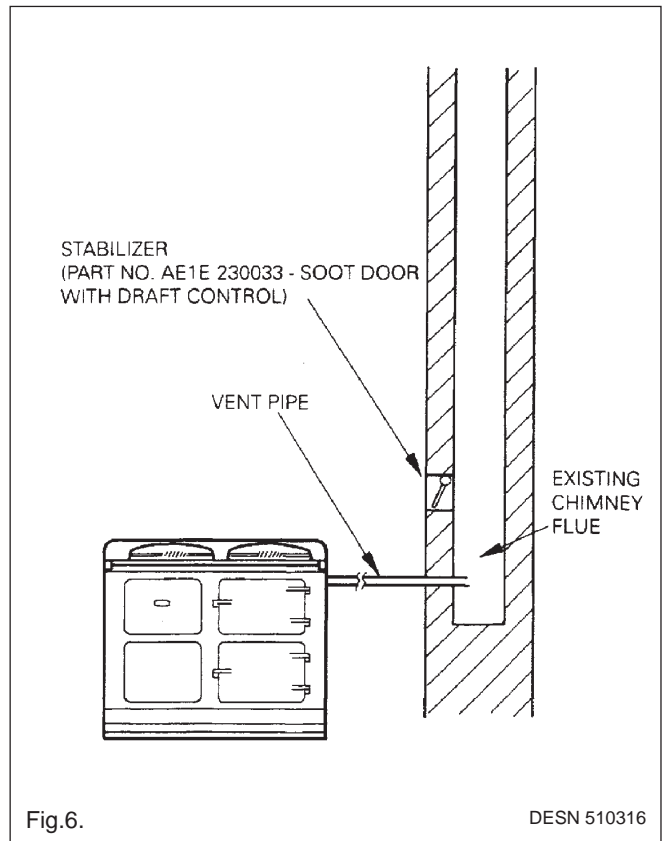
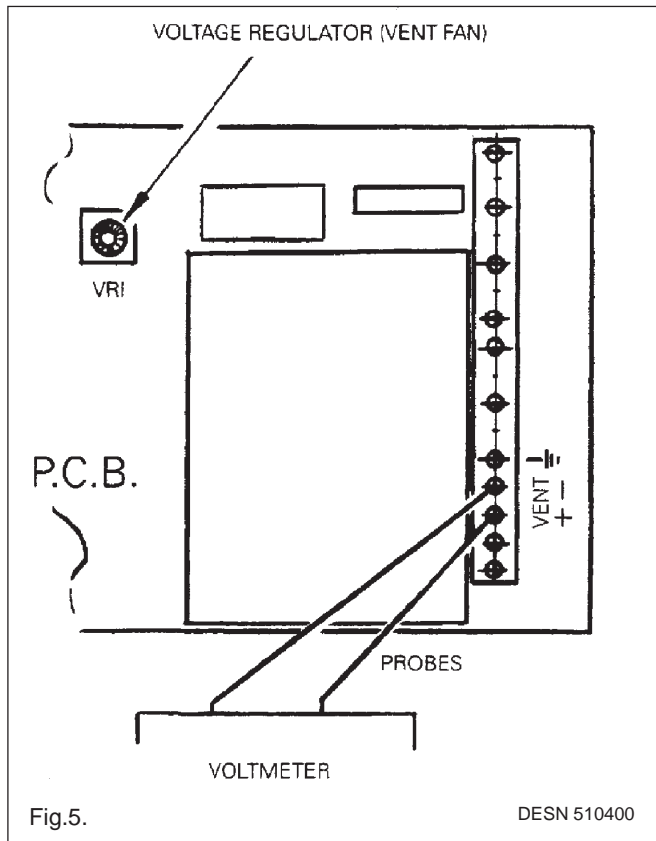

## SITE ERECTION

Following the completion of cooker erection, specific electrical checks must be made, **before** power is connected, by competent personnel equipped with suitable instrumentation. These electrical checks are outlined in detail in test document EINS 510158 titled 'Electric Aga Safety Check' and the Test Report should be completed and ultimately signed by the individual involved.

Connection between the meter and cooker can now be finalised and power switched ON.

## INITIAL COMMISSIONING OF COOKER

**NOTE: AS THE COOKER WILL GRADUALLY HEATS UP, SOME SMELLS AND FUMES WILL BE DRIVEN OFF FROM THE INTERNAL COOKER INSULATION, WHICH WILL CONTINUE FOR ABOUT 5 HOURS UNTIL FINALLY DISSIPATED. TO MINIMISE THIS INITIAL INCONVENIENCE, THE COOKER KITCHEN AREA SHOULD BE CONTINUOUSLY WINDOW-VENTED THROUGHOUT THIS PERIOD AND THE USER ADVISED TO AVOID ENTERING THIS AREA IF POSSIBLE, UNTIL FINALLY CLEAR OF SMELLS.**

**FOLLOWING COMMISSIONING, COPIES OF THE COMPLETED TEST REPORT SHOULD BE RETURNED TO AGA WORKS.**



**For further advice or information contact  
your local distributor/stockist**

With Aga's policy of continuous product improvement,  
the Company reserves the right to change  
specifications and make modifications to the appliances  
described and illustrated at any time.



Manufactured By  
Aga  
Station Road  
Ketley Telford  
Shropshire TF1 5AQ  
England

[www.aga-web.co.uk](http://www.aga-web.co.uk)  
[www.agacookshop.co.uk](http://www.agacookshop.co.uk)  
[www.agalinks.com](http://www.agalinks.com)