

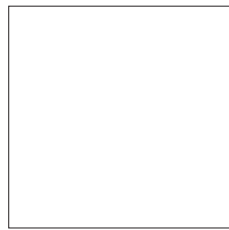

Masterchef



100 DF FSD

User's Manual

&

Installation and Servicing Instructions

PLEASE READ THESE INSTRUCTIONS BEFORE USING THIS APPLIANCE

CE For use in GB and IE

05/06 EINS 514327

Be safe

Warning

Accessible parts will become hot in use. To avoid burns and scalds children should be kept away.

You need clean fresh air - so does your cooker. Burner flames produce exhaust gases, heat and moisture. Make sure that the kitchen is well ventilated: keep natural ventilation holes open or install a powered cooker hood that vents outside. If you have several burners on or use the cooker for a long time, open a window or turn on an extractor fan. For more detail see the Installation Instructions.

We recommend you read the 'General Safety Instructions' section if you have not used a gas cooker before.

We describe some basic guidelines on how to use a gas cooker safely.

Gas and Electricity on

Make sure that the gas supply is turned on and that the cooker is wired in and switched on. The cooker needs electricity.

Peculiar smells

When you first use your cooker it may give off a slight odour and a little smoke. This is normal and harmless (from oven lagging and starch binder on the element insulation) and will cease after a short period of use.

Contents

Users Guide

Hotplate Burners	Page 4
The Griddle	Page 5
The Slow Cooking Oven	Page 6
Ideas for the Slow Cooking Oven	Page 7
The Grill (Top Right)	Page 11
The Fan Ovens	Page 12
The Clock	Page 13
Oven Cooking Guide	Page 16
Fan oven cooking chart	Page 19
Cleaning your cooker	Page 20
Troubleshooting	Page 24
General Safety Instructions	Page 26

Installation Guide

Installation	Page 28
Servicing	Page 35
Circuit Diagram	Page 40
Technical Data	Page 43

Hotplate Burners

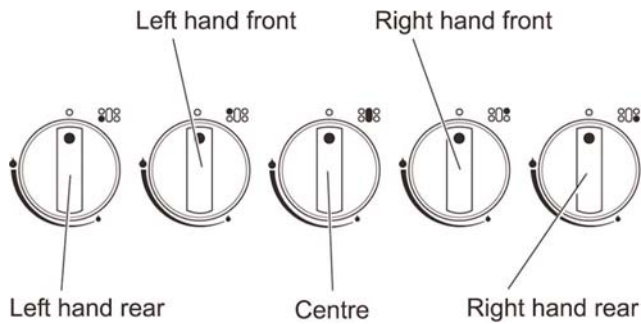

The drawing above each knob indicates which burner that knob controls. There is a spark ignition system that works when the knob is pressed in. Each burner also has a special safety device that stops the flow of gas if the flame goes out.

Push in and turn a knob to the large flame symbol (●).

Keep holding the knob pressed in to let the gas through to the burner for few seconds. The igniter will spark and light the gas automatically.

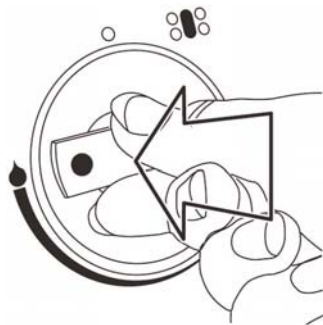

If, when you let go of the control knob, the burner goes out, the safety device has not held in. Turn the control to the off position and wait one minute, then try again this time holding in the control knob for slightly longer.

Adjust the flame height to suit by turning the knob.

On this cooker the low position is beyond high, **not** between high and off. The small flame (●) marks the 'low position'.

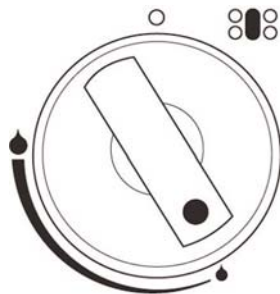

Turn the knob towards it after the contents of a pan have boiled.

Place all pans centrally over the burners. The flames must be on the base of the pan. Do not allow the flames to go up the sides of the pan.

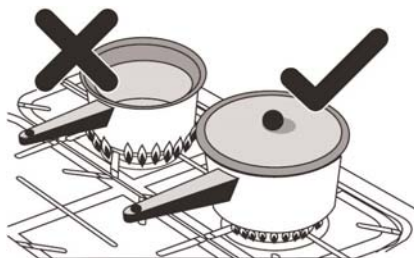

Using a lid will help the contents boil more quickly.

Always position pan handles away from the front of the cooker, out of reach of small children.

Pan and kettles with concave bases or down turned base rims should not be used.



Simmering aids, such as asbestos or mesh mats, are NOT recommended. They will reduce burner performance and could damage the pan supports.

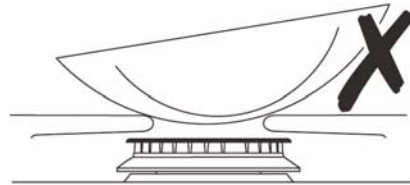

Avoid using unstable and misshapen pans that may tilt easily and pans with a very small base diameter e.g. milk pans, single egg poachers.

Minimum pan sizes

The minimum pan diameter recommended is 120mm (about 4 3/4").

When hotplate control knob is pressed in, sparks will be made at every burner, this is normal.

If after lighting, a hotplate burner's flame goes out, turn it off and leave it for one minute before relighting it.

IMPORTANT: The cast iron pan supports on the appliance are of professional design and much heavier than most if not all gas hob cookers. Therefore care must be taken when removing or refitting them from or to the hob. It is important that they are lifted from the appliance. Do not drag them across adjacent enamelled components as this could damage the enamel.

You can remove the burner head for cleaning. See the 'Cleaning your cooker' section of these instructions for removal and fitting of the pan supports and burner parts.

You should wipe the top surface of the cooker around the hotplate burners as soon as possible after spills occur. Try to wipe them off while the hotplate is still warm.

Deep Fat Frying

- Use a deep pan large enough to completely cover the appropriate heating area.
- Never fill the pan more than one-third full of fat or oil.
- Never leave fat or oil unattended during the heating or cooking period.
- Never use a lid on the pan.
- **IMPORTANT:** Oil is a fire risk; do not leave pans containing oil unattended.
- In the event of fire cover with a lid and turn OFF the appliance.

Do not attempt to extinguish the fire using water. Smother the flames on the hob, rather than attempting to remove the pan to the outside.

Burns and injuries are caused almost invariably by picking up the burning pan to carry outside.

- Do not try to fry too much food at a time, especially frozen food. This only lowers the temperature of the oil or fat too much, resulting in greasy food.
- Always dry food thoroughly before frying and lower it slowly into the hot oil or fat. Frozen foods in particular, will cause frothing or spitting, if added too quickly.
- Keep the outside of the pan, clean and free from streaks of oil or fat.

NOTE: Use of aluminium pans may cause metallic marking of the pan supports. This does not affect the durability of the enamel and may be cleaned off with a metal cleaner such as 'Brasso'.

Fish Kettle Burner

The central hotplate burner can be used to cook whole salmon, trout, etc. in a fish kettle.

Suggested Method for cooking whole Salmon

Place the gutted and cleaned fish, with or without head and tail in to the kettle with sufficient water to almost cover the fish. Season with salt and pepper and add a few pieces of carrot, onion and parsley to give flavour. Bring to the boil, covered and simmer for 8 10 10 mins per 450g.

When cooked, leave to cool in the liquid before draining and removing the skin. Decorate as desired.

The Griddle

The griddle fits the central fish kettle/griddle pan support, front to back. It is designed for cooking food on directly. Don't use pans of any kind on it. The griddle surface is non-stick and metal cooking utensils (e.g. spatulas) will damage the surface. Use heat resistant plastic or wood utensils.

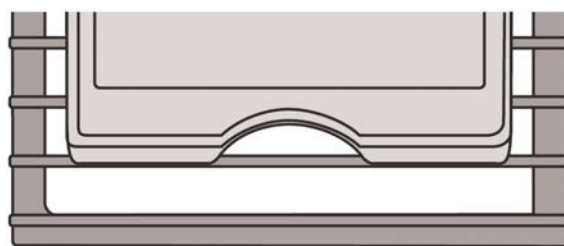
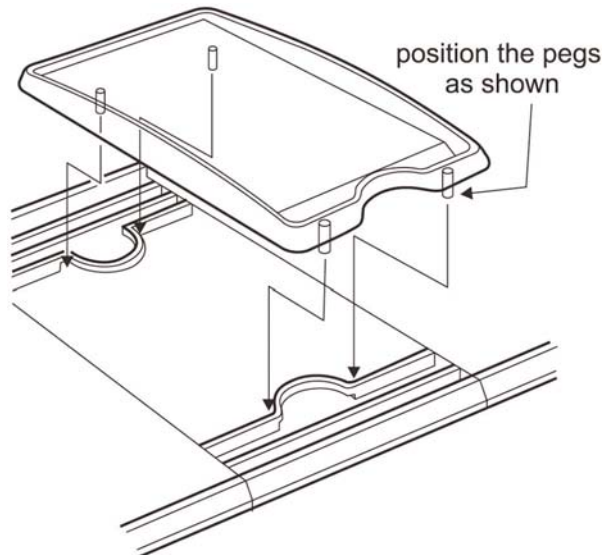

It should be positioned on the pan supports as shown to ensure correct and safe operation.

- Don't put it crossways - it will not fit properly and will be unstable.
- Don't put it on the Wok burner - it is not designed to fit the Wok burner pan support.

The griddle can be lightly brushed with cooking oil before use. Light the burner and adjust the flame height to suit.

Pre-heat the griddle for 5 to 10 minutes before adding food. Leaving it long may cause damage.

You can reduce the heat by turning the control knobs towards the lower position (marked with the small flame symbol).

Always leave space around the griddle for the gases to escape. **Never** fit two griddles side by side. Large pans should also be spaced well apart.

- Experience will soon familiarise you with the correct setting to use for cooking.
- After cooking allow the griddle to cool before cleaning.



The Slow Cooking Oven

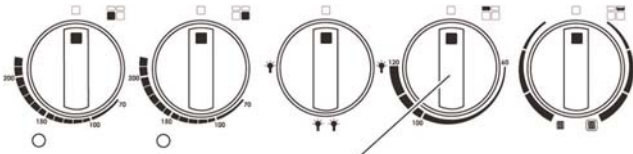

Slow cooking oven control knob

This oven is for long, slow cooking over 6-8 hours, keeping food warm and warming plates for short periods.

Extra care must be taken when warming bone china - use the lowest setting.

Using the Slow Cooking Setting

The slow cooking setting is the area marked between 110°C - 120°C on the oven control knob.

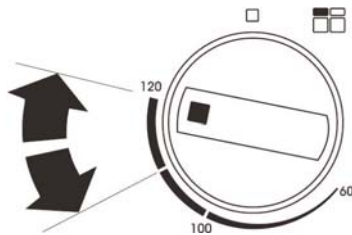

The slow cooking oven has side panels that are coated with a special enamel that partly cleans itself. For more on cleaning the ovens see the 'Cleaning your cooker' section of these instructions.

Points to bear in mind when preparing food.

Do not place dishes directly on to the oven base. Always place onto shelf supplied.

The shelf is designed to lock in place, but is removable for cleaning. See the 'Cleaning your cooker' section of these instructions.

Push dishes well back in the oven to ensure that they are positioned over the element beneath the base plate.

Make sure all dishes will fit into the oven before preparing the food.

All dishes cooked by the slow cooking method should be cooked for a minimum of 6 hours. They will 'hold' at this setting for a further 1-2 hours but marked deterioration in appearance will be notice in some cases.

Joints of meat and poultry should be cooked at 180°C for 30 minutes before transferring to the slow cooking oven.

Meat over 2.7 kg (6lbs) and poultry over 2kg (4lbs 8ozs) are unsuitable for the slow cooking method.

Always stand covered joints on a rack over a meat tin, to allow good air circulation.

Make sure that pork and poultry reach an internal temperature of at least 90°C.

Slow cooking is unsuitable for stuffed meat and poultry.

Always bring soups, casseroles and liquids to the boil before putting in the oven. When casseroles are used, cover the food first with foil and then the lid to prevent loss of moisture.

Always thaw frozen food completely before cooking.

Root vegetables will cook better if cut into small pieces.

Adjust seasonings and thickenings at the end of the cooking time.

Egg and fish dishes need only 1-5 hours cooking and should be included in day cooking sessions, where they can be observed from time to time.

Dried red kidney beans must be boiled for a minimum of ten minutes, after soaking, and before inclusion in any dish.

Storage and Re-Heating of Food

If food is to be frozen or not served immediately, cool it in a clean container as quickly as possible.

Thaw frozen food completely in the refrigerator before re-heating.

Re-heat food thoroughly and quickly either on the hotplate or in a hot oven 180°C, and then serve immediately.

Only re-heat food once.

Ideas for the Slow Cooking Oven

Many favourite recipes can be adapted for this type of cooking:

Slow Cooking Oven Recipes - Meal 1

6 - 8 hours cooking time

Ragout of Beef in Ale

Baked Potatoes

Rice Pudding

Ingredients

Method

Ragout of Beef in Ale

30ml (2tbsps) oil
675g (1 1/2 lbs) chuck steak, cubed
1 clove of garlic, crushed
2 carrots, sliced
100g (4oz) mushrooms, quartered
2 medium onions, sliced
40g (1 1/2 ozs) plain flour
5ml (1 tsp) coarse-grained mustard
10ml (1 dsp) Demerara sugar
30ml (2tbsps) tomato purée
450ml (3/4 pt) brown ale
salt and freshly ground pepper

1. Sauté the meat in a casserole in hot oil until brown. Remove.
2. Sauté the garlic, onions, carrots and mushrooms until brown.
3. Stir in flour and mix well.
4. Add mustard, sugar and tomato purée.
5. Stir in the ale and seasoning. Return meat.
6. Bring to the boiler and cover. Transfer to the oven.

Baked Potatoes

4 medium sized potatoes

1. Wash and prick well all over.
2. Wrap in one layer of foil.
3. Place directly on the shelf in between the casserole and rice pudding.

Rice Pudding

*40-50g (1 1/2 - 2 ozs) pudding rice
25g (1oz) sugar
550ml (1 pt) milk
nutmeg
knob of butter
25g (1oz) sultanas (optional)

1. Wash the rice in cold water and place in an 850ml (1 1/2 pt) pie dish.
2. Add the sugar, milk and sultanas if using.
3. Sprinkle with nutmeg and add a good knob of butter.

*** If cooking for 8 hours or more use 40g (1 1/2oz) rice only**

Slow Cooking Oven Recipes - Meal 2

6 - 8 hours cooking time

Roast Fillet of Lamb

Dauphinoise Potatoes

Bread and Butter Pudding

Ingredients

Method

Roast fillet of Lamb

900g - 1.25 kg (2 - 2 1/2lbs) lamb

1. Season and wrap the lamb in foil.
2. Stand meat on a rack over a small roasting tin.

Dauphinoise Potatoes

450g (1 lb) potatoes, thinly sliced
1-2 cloves of garlic, crushed
125ml (1/4 pt) double cream
salt and freshly ground black pepper

1. Grease a shallow oval or rectangular dish.
2. Arrange layers of potatoes, seasoning and garlic in the dish, ending with potatoes.
3. Pour over the cream and cover well with foil.

Bread and Butter Pudding

6-8 medium slices of wholemeal bread
Approx 50g (2ozs) butter, melted
Grated rind of one orange (optional)
25g (1oz) desiccated coconut
50 - 100g (2 - 4oz) luxury/tropical mixed fruit
50g (2oz) soft brown sugar
450ml (3/4 pt) milk
2 eggs

1. Grease a shallow oval or rectangular dish.
2. Cut the crusts off the bread and divide into rectangles/triangles.
3. Dip enough pieces of bread in the butter on one side to cover the base of the dish, butter side up.
4. Sprinkle with half of the fruit, coconut, sugar and orange rind.
5. Cover with a second layer of bread dipped in the butter and then the remaining rind, fruit, coconut and sugar.
6. Whisk the eggs and milk together and pour over the bread, Stand for 1/2 hour before baking. Leave uncovered in the oven.

Slow Cooking Oven Recipes - Meal 3

6 - 8 hours cooking time

Gammon and Apricot Pie

Braised Red Cabbage

St. Clements Pudding

Ingredients

Method

Gammon and Apricot Pie

2 gammon rashers approx 15mm (1/2") thick
100g (4oz) no-soak dried apricots
25g (1oz) sultanas
3 large potatoes, thinly sliced
300ml (1/2 pt) chicken stock
50g (2oz) butter, melted

1. Remove the rind from the gammon. Nick the edges and lay them in a shallow dish.
2. Sprinkle with apricots, sultanas and pepper.
3. Overlap the sliced potatoes on top of the gammon. Pour over stock.
4. Brush with melted butter, place in the oven

Braised Red Cabbage

350g (3/4 lb) red cabbage
25g (1oz) butter
1 medium onion, sliced
1 medium cooking apple, sliced
30ml (2 tbsps) cider vinegar
45ml (3 tbsps) honey
salt and pepper

1. Slice the red cabbage finely.
2. Melt the butter in an oval casserole dish and sauté the onion and apple until starting to soften.
3. Add the cabbage and cook for a further 2 minutes.
4. Mix in the vinegar, honey and seasoning.
5. Cover with buttered greaseproof paper and a tightly fitting lid, covered in foil. Place in the oven.

St Clements Pudding

2 rounds of thick sliced wholemeal bread
a little milk
50g (2oz) butter or margarine
50g (2oz) soft brown sugar
grated rind and juice of 1 lemon
grated rind and juice of 1 orange
3 eggs, separated
caster sugar for sprinkling

1. Grease a shallow ovenproof dish and line the base with fingers of bread.
2. Pour over sufficient milk to be absorbed by the bread.
3. Cream the fat and sugar.
4. Add the yolks, lemon and grated rind and juice. Beat.
5. Whisk the egg whites stiffly and fold most of them into the creamed mixture.
6. Spread the mixture over the bread.
7. Finish with a layer of the remaining egg white, thickly dredged with sugar. Leave uncovered. Place in the oven.

Slow Cooking Oven Recipes - Meal 4

6 - 8 hours cooking time

Chilli Con Carne

Oven Rice

Frangipane and Apple Pudding

Ingredients

Method

Chilli Con Carne

450g (1 lb) minced beef
1 x 400g (14 oz) tin tomatoes
1 x 400g (14oz) tin kidney beans
1 packed Chilli con carne spice mix
100ml (4 fl oz) water

1. Brown the minced beef in an oval casserole dish.
2. Stir in the spice mix.
3. Add beans drained, tomatoes and water.
4. Mix well together. Bring to boil, cover well and place in oven.

Oven Rice

225g (8oz) long grained rice
350ml (12 fl ozs) water
seasoning

1. Wash rice and place in an oval casserole dish.
2. Pour on water, seasoning and bring to the boil.
3. Cover well and place in oven.

Frangipane and Apple Pudding

450g (1 lb) cooking apples, grated
50g (2 oz) vanilla fudge, chopped
50g (2 oz) softened butter
50g (2 oz) soft brown sugar
50g (2 oz) ground almonds
12g (1/2 oz) plain flour
1 egg
almond essence

1. Grease a shallow oven dish.
2. Mix the apples and fudge together and place into the dish.
3. Cream the rest of the ingredients and add a few drops of almond essence.
4. Carefully spread over the apple. Leave uncovered and place in oven.



The grill pan fits on the shelf supplied (shown out of the grill chamber for clarity).

The shelf is designed to lock in place, but is removable for cleaning. See the 'Cleaning your cooker' section of these instructions.

Make sure the grill pan is pushed right to the back of the grill chamber.

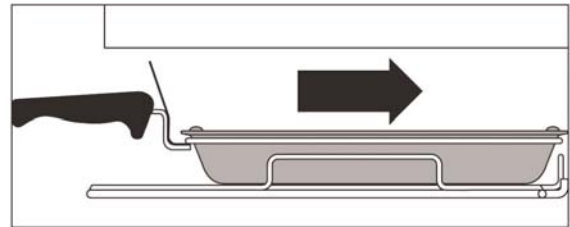

Food should be cooked on the grid or in the base of the grill pan. You can brown the top of dishes, cooked in the oven, under the grill by placing the dish onto the base of the grill pan, which can easily slide along the floor of the grill cavity.

The grill chamber has side panels that are coated with a special enamel that partly cleans itself. For more on cleaning the cooker see the 'Cleaning your cooker' section of these instructions.

The Grill (Top Right)

CAUTION: Accessible parts may be hot when the grill is in use. Young children should be kept away.

If you find a crack in the glass surface of the grill **immediately** disconnect the appliance from the electricity supply. Do not reconnect the appliance until it is repaired.

THE GRILL COMPARTMENT DOOR MUST BE KEPT OPEN WHEN THE GRILL IS ON.

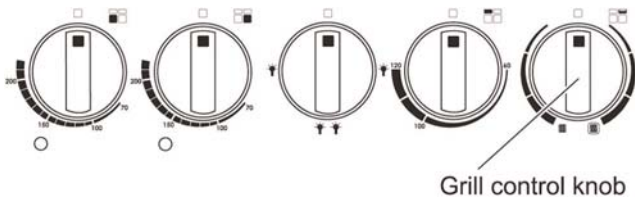

The very high speed instant grill is divided into two areas to save energy and to suit individual grilling requirements.

Turn the grill control clockwise and the whole of the grilling area can be used for large amount of food.

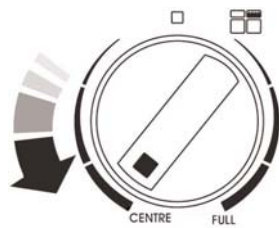

For small amounts of food e.g. 2 slices of toast, one or two chops etc. turn the control anti-clockwise. Only the middle area of the grill heats up.

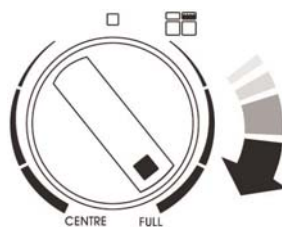

Most is cooked at a high setting but for thicker pieces of meat/poultry and for food such as well done steak the heat can be reduced by turning the control down to a lower setting.

For best results pre-heat at a high setting for approximately 2 minutes.



The Fan Ovens

During use the appliance becomes hot. Care should be taken to avoid touching the heating elements inside the ovens.

The clock must be set to the time of day before the left hand oven will work. See 'The Clock' section of these instructions for how to set the clock.

Both the lower ovens are fan ovens. The fans circulate hot air continuously, which means faster more even cooking.

It is only necessary to pre-heat the ovens for food such as scones, puff pastry, Yorkshire Pudding, bread etc.

To operate either oven

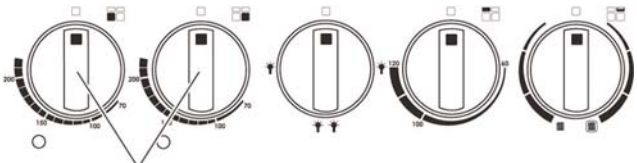

Fan oven control knobs

Before using for the first time, heat the ovens to 200°C for 30 minutes to dispel manufacturing odours.

The recommended cooking temperatures for fanned ovens are generally lower than non-fanned ovens.

Turn the oven temperature knob to the temperature you need.

The oven indicator light will glow until the oven has reached the temperature you selected.

It will then cycle on and off during cooking.

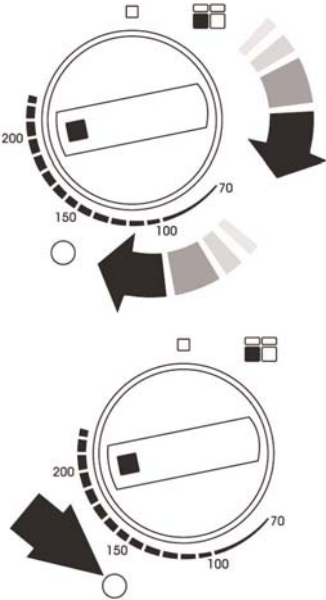

The Oven Lights

Turn the oven light knob to the left for the left hand oven light and to the right for the right hand oven light. To turn on both lights turn the knob to the bottom position.

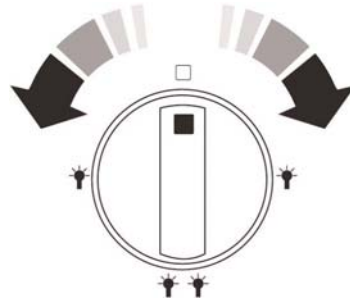

The Clock

You can use the timer to turn the left hand oven on and off. The clock must be set to the time of day before the left hand oven will work.

To set the time of day

Press and hold as shown. At the same time, press (-) or (+) until the correct time shows.

Don't forget it's a 24 hour clock.

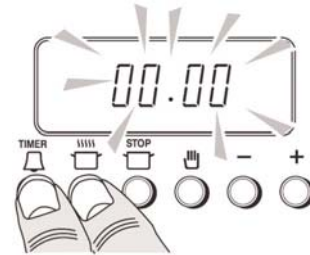

If you make a mistake or press the wrong button, turn off the power supply for a minute or two and start again.

If the key symbol () appears on the left of the display you have accidentally turned on the key lock feature. See the section 'Clock Special Features'.

To time something that's cooking (minute minder)

Press and hold the Minute Minder ().

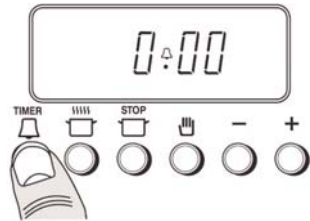

At the same time press (-) or (+) until the time you want to cook for is shown.



You can check time remaining by pressing () and cancel the beeper by pressing ().

To stop automatically

Use when you have started the oven manually.

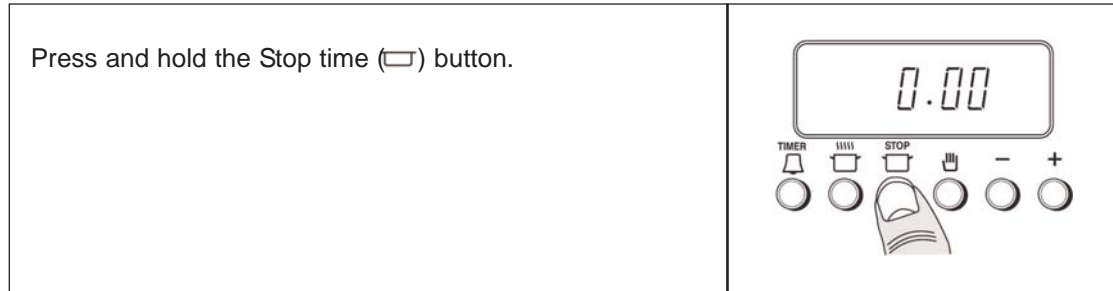

At the same time press (-) or (+) until your required 'Stop Time' shows. AUTO will show in the display. When your cooking is finished the beeper sounds. TURN THE OVEN KNOB TO 0 FIRST, then press (☐) once to stop the beep, press (☐) again to return to manual cooking.

To start and stop the oven automatically

Before you set the clock, you must have two numbers clearly in mind.

The 'cook period', which is the period of time you want the oven to cook.

The 'stop time', which is the time of day you want the oven to stop cooking.

You cannot set a start time directly - this is set automatically by setting the cooking period and stop time.

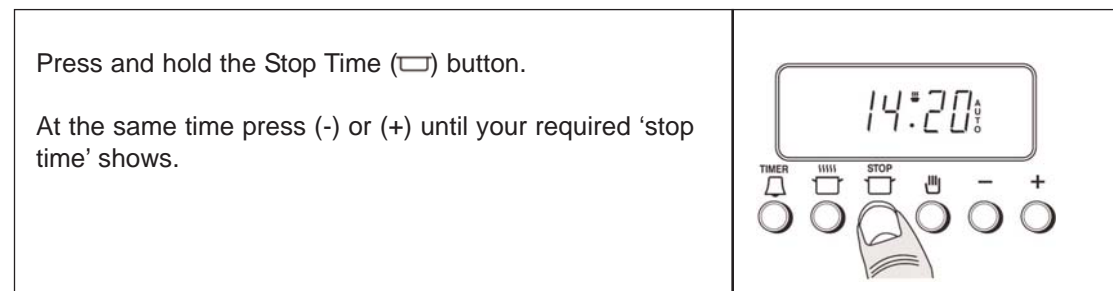
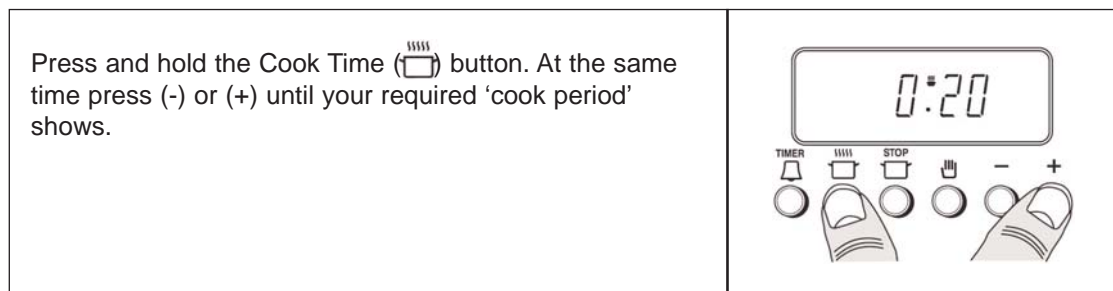

AUTO will show in the display.

Set the oven to the required temperature. When your cooking is finished the beeper sounds. TURN THE OVEN KNOB TO 0 FIRST, then press (☐) once to stop the beeper, press (☐) again to return to manual cooking.

If you are out, don't worry about the beeper going off, it stops after a while. When you return, TURN THE OVEN KNOB TO 0 FIRST, then press (☐) twice, to return to manual cooking.

Auto is showing, you want to reset to manual cooking

When cancelling an automatic setting, any cooking time already set must be returned to 0.00 before you can return to manual, by pressing the (☐) button.

Clock Special Features

Key Lock

When the key lock is activated, the clock can be operated as usual but the oven is locked and will not come on. This means that your child could select a cook programme but the programme will not be activated and oven will not be switched on.

To activate the key lock

Make sure that the clock is in manual and cancel any active programmes.

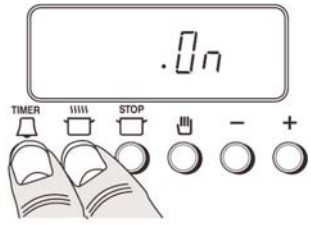
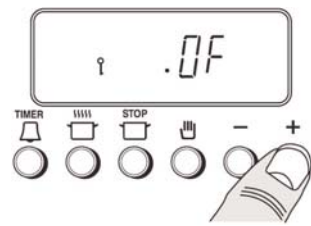
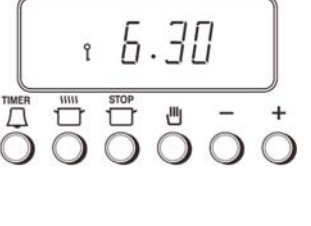
<p>Hold the Minute Minder (🔔) and Cook Time (👉) buttons for about 8 seconds.</p> <p>On will appear on the display.</p>	
<p>Press the (+) button once.</p> <p>'Of' will appear on the display.</p>	
<p>The clock oven control functions are now locked.</p> <p>After a few seconds the display will revert to show the time of day and the key symbol (🔑).</p>	

To turn off the key lock

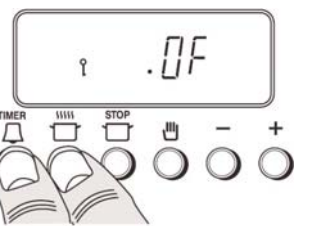
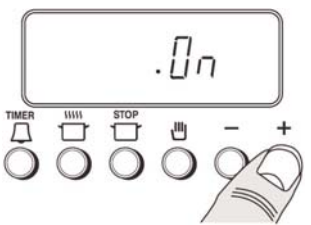
<p>Hold the Minute Minder (🔔) and Cook Time (👉) buttons for about 8 seconds.</p> <p>'Of' will appear on the display.</p>	
<p>Press the (+) button once. 'On' will appear on the display.</p>	

After a few seconds the display will revert to shown the time of day.

The oven and the clock oven control functions can now be used normally.

Oven Cooking Guide

Cooking Hints

When using the fan ovens, reduce conventional oven settings by 10°C - 20°C and cooking time by up to 10 minutes for every hour.

Fan oven cooking is particularly suitable for baking on several shelves at one time.

The wire shelves should always be pushed firmly to the back of the oven.

Baking trays, meat tins etc. should be placed level centrally on the oven shelves. Keep all trays and containers away from the sides of the oven, as ovenbrowning of the food may occur.

For even browning, the maximum recommended size of baking tray is 300mm x 240mm (12" x 9 1/2").

When the oven is on, do not leave the door open for longer than necessary, otherwise the knobs may get very hot.

Always leave a 'fingers width' between dishes on the same shelf; this allows the heat to circulate freely around them.

If you want to brown the base of a pastry dish, pre-heat the baking tray for 15 minutes before placing the dish in the centre of the tray.

Where dishes may boil and spill over during cooking, place them on a baking tray.

Please remember that all cookers vary - temperatures in your new AGA ovens may differ to those in your previous cooker. You can change the settings and cooking times to suit your tastes. It is important to check that food is piping hot before serving.

The cooking chart is a general guide but times and temperatures may vary according to individual recipes. The meat sections should be used as a general guide but may vary according to the size, shape of joint on or off the bone.

Thaw frozen joints before cooking them.

The times are for open roasting, If covered allow extra time.

The turkey/chicken is cooked when the juices run clear when pierced with a skewer. If the juices are still pink continue to cook checking every 15 minutes.

Do not place the shelf or food on the base of the ovens.

For effective heat distribution, leave at least a fingers with between dishes and between dishes and the sides of the oven.

Steam

When cooking foods with high water content (e.g. oven chips) there may be some steam visible at the grille at the rear of the hotplate.

Condensation may form on the cooker. This is quite normal and nothing to worry about. The condensation forms when heat and moisture are present. Whenever possible try to make sure that food which contains a lot of moisture for example casseroles are covered. If you do notice any condensation, wipe it up straight away. Do not leave food in the oven to cool after it has been switched off.

Cooking high moisture content foods can create a 'steam burst', when the oven door is opened. When opening the oven stand well back and allow any steam to disperse.

General

The fan ovens are fitted with side, roof and back panels that are coated with a special enamel that partly cleans itself. The oven liners (see Cleaning your cooker) work better when fat splashes are avoided. Cover meat when cooking.

To reduce fat splashing when you add vegetables to hot fat around a roast, dry them thoroughly or brush lightly with cooking oil.

For more on cleaning the ovens see the 'Cleaning your cooker' section of these instructions.

Do not allow young children to stand on the drop down oven doors.

The Fan oven shelves

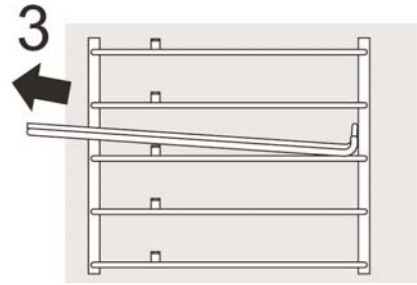
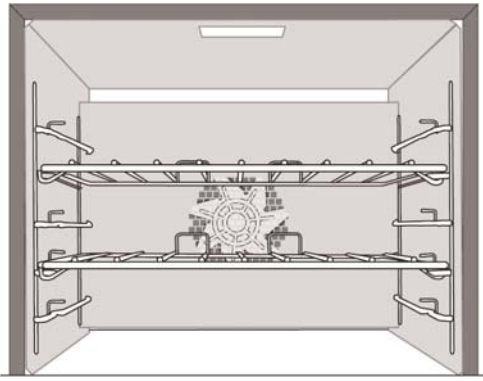

To refit the shelf, hold it so it is slightly up at the front and rest the back of the shelf on the side wires. Push the shelf to the back of the oven and then lower the front so that it is resting on the side wires.

The shelves should not be fitted directly one above the other. When cooking on more than one shelf always at least one runner space between them.

The oven shelves are retained when pulled forward but can easily be removed and refitted.

To remove a shelf first make sure it is pushed fully back, so that the shelf stop is in line with the kink in the side of the shelf.

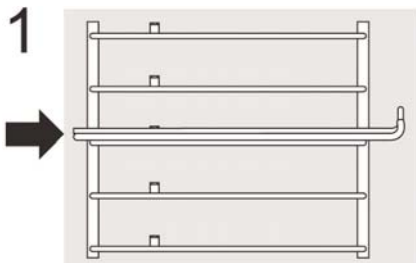
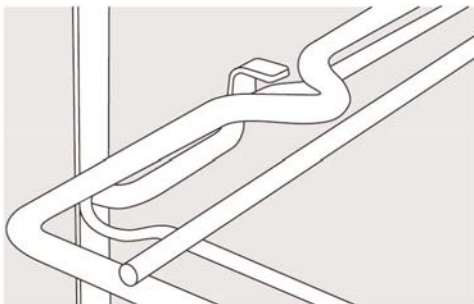

Lift up the front of the shelf so the shelf will pass over the shelf stop.

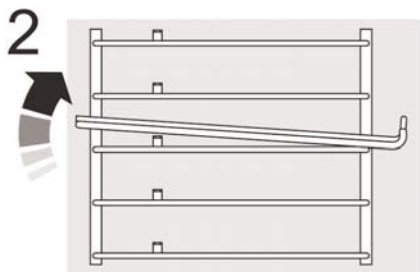

Pull the shelf forward.

The oven control settings and cooking times give in the table are intended to be used only as a guide. Individual tastes may require the temperature to be altered to provide a preferred result.

There may be a slight difference in the results between the two ovens. This is due to manufacturing tolerances and it may be necessary to alter times and temperature settings to allow for this.

Food is cooked at a lower temperature in a fan oven than in a conventional oven. When using recipes, reduce the temperature by 10°C and the cooking time by 5 - 10 minutes. The temperature in the fanned oven does not vary with height in the oven - so you can use any shelf.

Always leave at least one runner space between shelves when 2 tier cooking. Place baking trays, individual cake tins or baking dishes on the oven shelf. For best results pre-heat the oven until the oven indicator light goes out.

Fan oven cooking chart

FOOD	SETTING °C	APPROXIMATE COOKING TIME
FISH		
Whole Fish e.g. trout, mackerel	170	25 - 30 mins depending on size
Steaks	170	20 - 25 mins depending on thickness
Oven-fried fish	210	25 mins depending on packet instructions
Salmon (2.7kg)	140 - 150	15 - 18 mins per 450g
MEAT & POULTRY		
Beef	170 - 180	30 mins per 450g + 30 mins over (medium rare)
Lamb	170 - 180	25 mins per 450g + 25 mins over
Pork	170 - 180	30 - 35 mins per 450g + 35 mins over
Chicken	170 - 180	20 - 25 mins per 450g + 20 mins over
Turkey	160	15 - 18 mins per 450g + 15 mins over
Duck & Goose	170 - 180	25 mins per lb + 25 mins over
Casserole	130 - 140	1 1/2 - 3 hours depending on recipe
PUDDING		
Milk Puddings	140	2 hours
Baked Custard	130	35 mins
Baked Sponge Pudding	170	45 mins - 1 hour using raw fruit
Fruit Crumble	170 - 180	45 mins - 1 hour
Meringue Toppings	130	45 mins
Meringue	80 - 90	3 - 4 hours - Turn meringues over as soon as they are set
YEAST MIXTURES		
Bread - loaves	200 - 210	30 - 45 mins
Bread - rolls	200 - 210	15 - 20 mins
Chelsea Buns etc.	180	25 - 35 mins
CAKES, PASTRIES, BISCUITS & SCONES		
Small Cakes	170	20 - 25 mins
Victoria Sandwich (250mm)	160 - 170	25 - 30 mins
Swiss Roll	200	7 - 10 mins
Fatless Sponge (180mm)	170	20 mins
Scones	200	10 - 15 mins
Maderia Cake	160	1 hour - Place on a piece of citron peel after 20 mins
Med. Rich Fruit Cake	130	2 - 2 1/2 hours
Christmas Cake (205mm)	130	4 - 4 1/2 hours
Gingerbread	130 - 140	1 - 1 1/2 hours
Shortbread	130	1 1/4 - 1 1/2 hours
Biscuits	150 - 170	15 - 25 mins depending on recipe
Tray Bakes & Tea Breads	160 - 170	30 mins - 1 1/2 hours depending on recipe
Shortcrust Pastry	190	Small Tarts 20 - 25 mins depending on recipe Pies 45 - 50 mins depending on recipe
Rich Shortcrust Pastry	180	25 mins
Flaky/Puff Pastry	200	8 - 10 mins depending on recipe
Choux Pastry	190	25 - 35 mins
MISCELLANEOUS		
Yorkshire Pudding - Large	200	45 mins
Yorkshire Pudding - Individual	200	20 - 25 mins
Souffles	170	45 mins

Cleaning your cooker

Essential Information

Before thorough cleaning isolate the electricity supply. Remember to switch on the electricity supply before use.

Never use paint solvents, washing soda, caustic cleaners, biological powders, bleach, chlorine based bleach cleaners, coarse abrasives or salt. Don't mix different cleaning products - they may react together with hazardous results.

Recommended cleaning materials are shown in the table at the end of this section.

If you want to move your cooker for cleaning, see the section called 'Moving your cooker'.

All parts of the cooker can be cleaned with hot soapy water - **but take care that no surplus water seeps into the appliance.**

For cleaning materials see the 'Cleaning Table' at the end of this section.

To Remove and Replace Pan Supports

IMPORTANT: The cast iron pan supports on the appliance are of professional design and much heavier than most if not all gas hob cookers. Therefore care must be taken when removing or re-fitting them from or to the hob. It is important that they are lifted from the appliance. Do not drag them across adjacent enamelled components as this could damage the enamel.

Lift off the bar at the back of the middle pan support, then remove the middle pan support, which is in one piece.

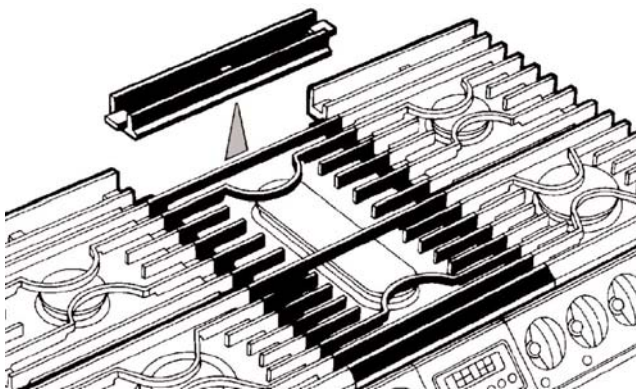

Remove the left and right hand individual pan supports. Replace the supports in reverse order.

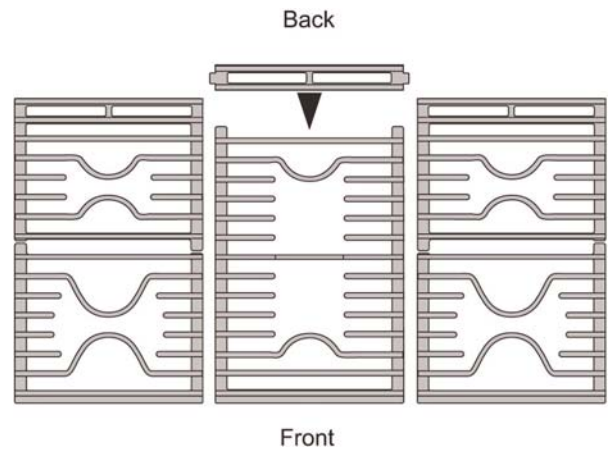

The position of each support on the hotplate is clearly marked on the underside, and can only be fitted in one

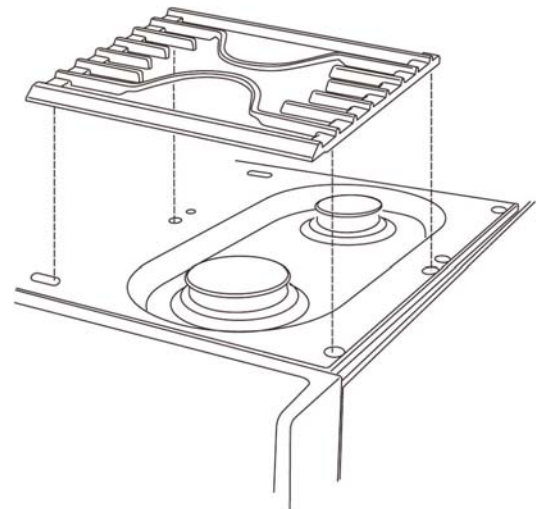

way.

Do not clean pan supports in a dishwasher. See the 'Cleaning Table'.

NOTE: Aluminium pans may cause a metallic marking on the pan supports. This will not affect the durability of the enamel. The appliance warranty does not cover misuse of the pan supports.

Stainless Steel Hob

Lift away pot and pans from hob. Remove pan supports from spillage area and carefully place in a sink of warm soapy water. Wipe loose debris from hob.

Avoid using any abrasive cleaners including cream cleaners, e.g. Cif, on brushed stainless steel surfaces. For best results use a liquid detergent e.g. Domestos Multi-Surface Cleaner.

Rinse with cold water and thoroughly dry with a clean, soft cloth. Ensure all parts are dry before repositioning.

Hotplate burners

The burner heads and caps can be removed for cleaning. Make sure they are absolutely dry before replacing.

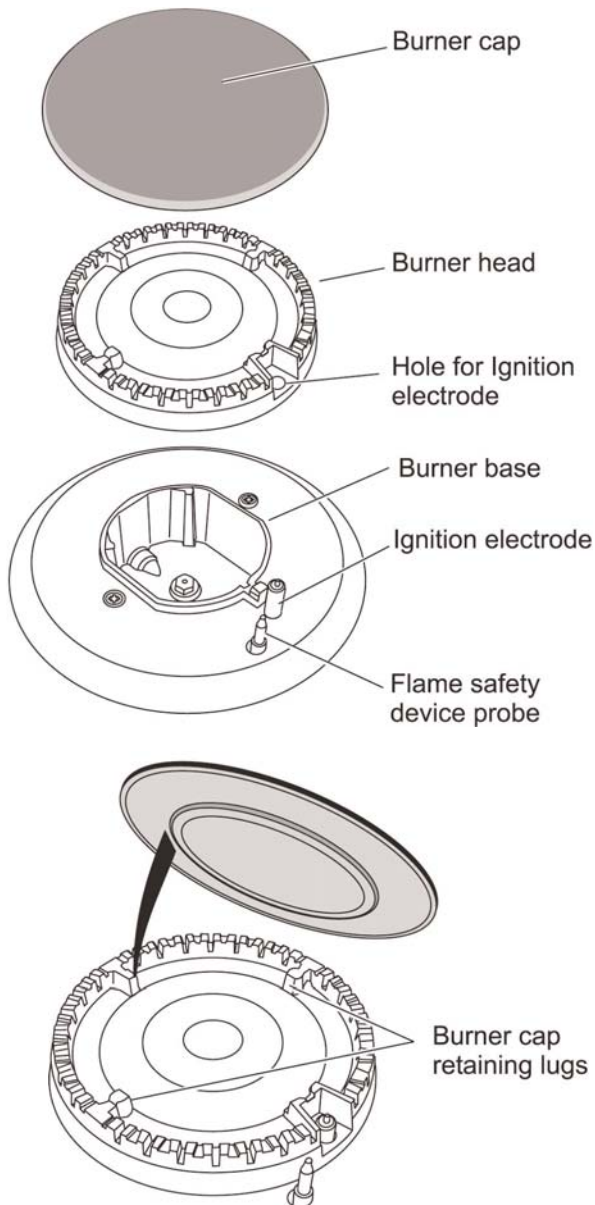

When fitting the burner head, make sure it locates properly within the bezel. Take care not to damage the ignition electrode or the flame safety device probe.

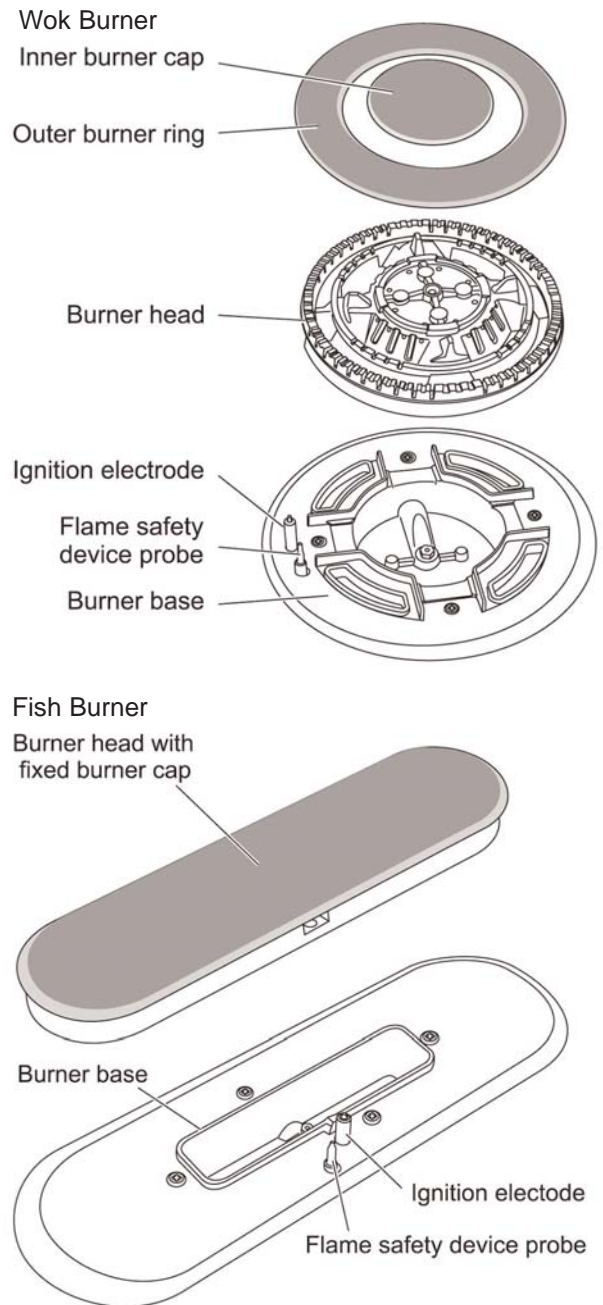

General

Check burner ports are not blocked. If blockage occurs, remove stubborn particles using a piece of fuse wire. Stubborn marks on the aluminium burner rings can be removed using a proprietary cleaner such as Brasso.

The Slow Cooking Oven and the Grill

The slow cooking oven and the grill have side panels that are coated with a special enamel that partly cleans itself.

Do not use any cleaning material which may clog the pores of the special coating e.g. Pastes and powders, soap filled pads, wire wool, spray cleaners, brush-on oven cleaners, caustic solutions, metal scrapers/knives, and prevent the continuous cleaning action.

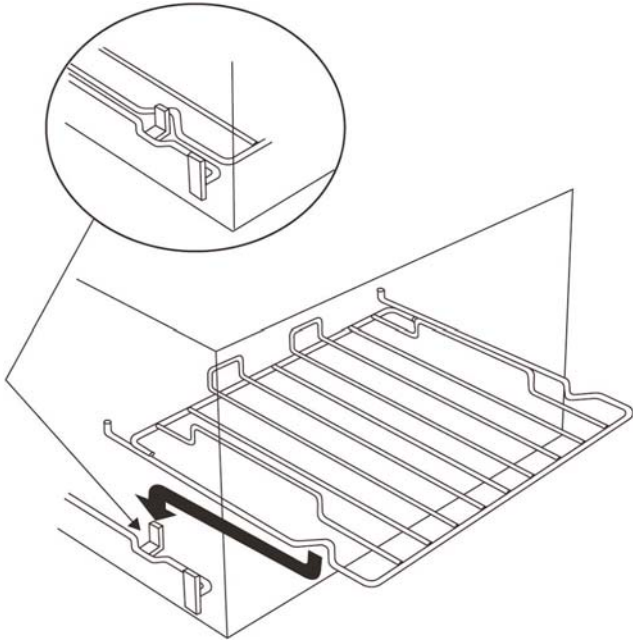

The shelf is designed to lock in place, but is removable for cleaning. To remove lift up at the front then pull forward.

The grill pan and grid should be washed in hot soapy water.

After grilling meats or any foods that soil, leave to soak for a few minutes in the sink immediately after use. Stubborn particles may be removed from the grid by using a nylon brush.

Control Panel and Oven Doors

For best results liquid detergents should be used.

The control panel and control knobs should only be cleaned with a soft cloth wrung out in clean hot soapy water - but take care that no surplus water seeps into the appliance. Wipe with a clean dampened cloth then polish with a dry cloth. The oven doors should only be cleaned with a soft cloth wrung out in clean hot soapy water.

The Fan Ovens

The ovens have panels which have been coated with a special enamel that partly cleans itself. This does not stop all marks on the lining, but helps to reduce the amount of manual cleaning needed.

The panels work best if a pattern of low and high temperature cooking is followed. Occasionally wipe with a lint free cloth and hot soapy water. When the panels are dry, heat the ovens to 200°C for about one hour. This will ensure the panels are working effectively.

Do not use steel wool (Brillo) or any other materials that will scratch the surface. Do not use oven cleaning pads.

Oven doors with windows (some models only)

If the inside face of the glass on window door model becomes marked, the glass panel can be taken off for cleaning.

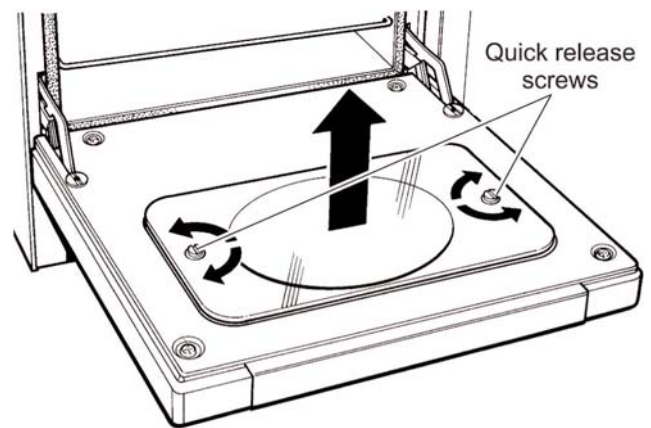

Open the oven door. To remove the glass turn the quick release screws for a quarter turn and carefully lift off the glass panel. After cleaning the glass make sure that it is completely dry before refitting.

Check that the glass is replaced the correct way.

Cleaning Table

Hotplate

Part	Finish	Recommended Cleaning Material
Hobplate Top	Enamel or Stainless Steel	Hot soapy water, soft cloth. Any stubborn stains remove gently with a nylon scourer.
Pan Supports, Wok Cradle (some models only)	Enamel coated Cast Iron or Stainless Steel	Cif Cream Cleaner - Faberge Lever and a nylon scourer.
Burner Caps	Enamel	Cream Cleaner, nylon scourer, Dishwasher
Burner Trim Rings (some models only) and Burner Head	Aluminium	Cif or other cream cleaner with a soft cloth. Be careful not to be over vigorous

Outside of cooker

Part	Finish	Recommended Cleaning Material
Door, Door surround	Enamel or paint	Hot soapy water, soft cloth. Any stubborn stains, remove gently with a liquid detergent.
	Stainless Steel	E Cloth (Comet) or Vileda Microfibre Plus All Purpose Cloth Freudenberg Household Products LP (supermarket)
Sides and Plinth	Painted surface	Hot soapy water, soft cloth
Rear Grille	Stainless Steel	Hot soapy water, soft cloth. Cream cleaner, with care if necessary.
Control panel	Paint, Enamel or Stainless Steel	Warm soapy water. Do not use abrasive cleaners on lettering.
Control knobs/handles	Plastic/Chrome	Warm soapy water, soft cloth.

Oven and Grill

Part	Finish	Recommended Cleaning Material
Cook & Clean Oven Panels	Special enamel that partly cleans itself	This surface cleans itself at 200°C and above, or the panels can be washed with hot soapy water and a nylon brush. (See 'The Ovens' in 'Cleaning your cooker').
Oven Shelves, Grill Trivet	Chrome	An oven interior cleaner that is suitable for chrome. Soap filled pad. Dishwasher.
Grill Pan/Meat Tin	Enamel	Hot soapy water. Soap filled pad (Brillo). Dishwasher.

Cleaners listed are available from supermarkets or electrical retailers as stated. Cleaner manufacturer in Italics.

For enamelled surfaces use a cleaner that is approved for use on vitreous enamel. The Vitreous Enamel Association has a list of approved cleaners. Contact them via their website www.ive.org.uk or telephone 01527 893031.

Regular cleaning is recommended. For easier cleaning, wipe up any spillages immediately.

To help keep your oven clean, cover meat when roasting, with foil or use a roasting bag. Brush vegetables with fat before placing around the meat.

Troubleshooting

Steam is coming from the oven

When cooking foods with a high water content (e.g. oven chips) there may be some steam visible at the rear grille. Take care when opening the oven door, as there may be a momentary puff of steam when the oven door is opened. Stand well back and allow any steam to disperse.

The oven fan is noisy

The note of the oven fan may change as the oven heats up - this is perfectly normal.

The knobs get hot when I use the oven or the grill, can I avoid this?

Yes, this is caused by heat rising from the oven or the grill, and heating them up. Do not leave the oven door open. Make sure that the grill is pushed right back to the 'backstop' when grilling.

If there is an installation problem and I don't get my original installer to come back to fix it who pays?

You do. Service organisations will charge for their call outs if they are correcting work carried out by your original installer. It is in your interest to track down your original installer.

Current Operated Earth Leakage Breakers

Where the cooker installation is protected by a 30-milliamp sensitivity residual current device (RCD), the combined use of your cooker and other domestic appliances may occasionally cause nuisance tripping. In these instances the cooker circuit may need to be protected by fitting 100mA device. This work should be carried out by a qualified electrician.

Food is cooking too slowly, too quickly, or burning

Cooking times may differ from your previous oven. Individual tastes may require the temperature to be altered either way, to get the results you want. Try cooking at different temperature setting.

The fan ovens are not cooking evenly

Do not use a tin or tray larger than 300mm x 240mm (12" x 9 1/2").

If you are cooking a large item, be prepared to turn it round during cooking.

If two shelves are used, check that space has been left for the heat to circulate. When a baking tray is put into the oven, make sure it is placed centrally on the shelf.

Check that the door seal is not damaged and that the door catch is adjusted so that the door is held firmly against the seal.

A dish of water when placed on the shelf should be the same depth all over. (For example, if it is deeper at the back, then the back of the cooker should be raised up or the front lowered). If the cooker is not level arrange for your supplier to level it for you.

Oven temperature getting hotter as the cooker gets older

If turning the knob down has not worked or only worked for a short time then you may need a new thermostat. This should be fitted by a service person.

Grill not cooking properly

Are you using the pan and trivet supplied with the cooker? Is the pan being used on the grill carriage, not the floor of the compartment? Is the grill tray fully back to the stop?

Hotplate ignition or hotplate burners faulty

Is the power on?

Are the sparker (ignition electrode) or burner slots blocked by debris?

Are the burner caps correctly located?

Hotplate burners will not light

If only one or all the hotplate burners will not light, make sure that the parts have been replaced correctly after wiping or removing for cleaning.

Check that there is not a problem with your gas supply. You can do this by making sure that other gas appliances you may have are working

Do the burners spark when you push in the control knob? If not, check the power is on.

The oven light is not working

The bulb has probably blown. You can buy a replacement bulb (which is not covered under the guarantee) from a good electrical shop. Ask for a 25W, 230V, 300°C, FOR OVENS. It must be a special bulb, heat resistant to 300°C.

Open the oven door and remove the oven shelves.

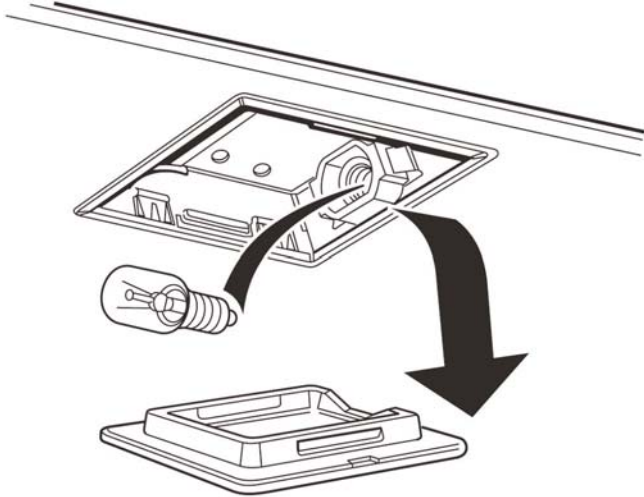
Turn off the power supply.

Unclip lamp lens and unscrew light bulb. Fit new light bulb and re-fit lens.

Turn on the electricity supply and check that the bulb now lights.

Power supply - You think there may be a problem with it

First check the socket by trying out another piece of electrical equipment in it.

If that works, replace the fuse in the cooker plug. Use a 3 amp fuse.

Power Failure

In the event of a failure in the electrical supply the hotplate maybe lit using a match.

If there is an installation problem and I don't get my original installer to come back to fix it who pays?

You do. Service organisations will charge for their call outs if they are correcting work carried out by your original installer. It is in your interest to track down your original installer.

What cleaning materials are recommended for the cooker?

See the 'Cleaning your cooker' section for recommended cleaning materials. We do not recommend Mr. Muscle, as it contains chemicals that may damage the surfaces of your cooker.

General Safety Instructions

In the UK the cooker must be installed by a CORGI registered engineer. In the Republic of Ireland, the installation must be carried out by a Competent Person.

The installation must be in accordance with the installation instructions and comply with the relevant regulations and also, the local gas and electricity supply companies requirements.

If you smell gas

Do not turn electric switches on or off.

Do not smoke

Do not use naked flames.

Do turn off the gas at the meter or cylinder.

Do open door and windows to get rid of the gas.

Call your gas supplier.

If you are using natural gas in the UK ring British Gas - Transco on

0800 111 999

This appliance is designed for domestic cooking only. Use for any other purpose could invalidate any warranty or liability claim.

The use of a gas cooking appliance results in the production of heat and moisture in the room in which it is used. Ensure that the kitchen is well ventilated: keep natural ventilation holes open or install a mechanical ventilation device, (mechanical extractor hood).

Prolonged intensive use may call for additional ventilation, for example opening a window. Use extractor fans or hoods when fitted.

The cooker should be serviced by a qualified service engineer and only approved spare parts used. Have the installer show you the location of the cooker control switch. Mark it for easy reference. Always allow the cooker to cool and then switch off at the mains before cleaning or carrying out any maintenance work, unless specified otherwise in this guide.

All parts of the cooker become hot with use and will retain heat even after you have stopped cooking.

Take care when touching the cooker, to minimise the possibility of burns, always be certain that the controls are in the OFF position and that it is cool before attempting to clean the cooker.

Use dry oven gloves where applicable - using damp gloves might result in steam burns when you touch a hot surface. Never operate the cooker with wet hands.

Do not use a towel or other bulky cloth in place of a glove. They might catch fire if they touch a hot surface.

Clean with caution. If a wet sponge or cloth is used to wipe up spills on a hot surface, be careful to avoid steam burns. Some cleansers can produce noxious fumes if applied to a hot surface.

Do not use unstable saucepan's and position the handles away from the edge of the hotplate.

Babies, toddlers and young children should not be allowed near the cooker at any time. They should never be allowed to sit or stand on any part of the appliance. Teach them not to play with controls or any other part of the cooker.

Never store anything of interest to children in cabinets above a cooker - children climbing on the cooker to reach them could be seriously injured.

Clean only parts listed in this guide.

In the interests of hygiene and safety the cooker should be kept clean at all times as a build up in fats and other food stuffs could result in a fire.

Always keep combustible wall coverings or curtains etc. a safe distance away from your cooker.

Do not spray aerosols in the vicinity of the cooker while it is on.

Do not store or use combustible materials, or flammable liquids in the vicinity of this appliance.

Do not use water on grease fires. Never pick up a flaming dish. Turn the controls off. Smother a flaming pan on a surface unit by covering the pan completely with a well fitting lid or baking tray. If available use a multi-purpose dry chemical or foam type fire extinguisher.

Never leave the hotplate unattended at high heat settings. Pans boiling over can cause smoking and greasy spills and may catch fire.

Never wear loose-fitting or hanging clothes while using the appliance. Be careful when reaching for items stored in cabinets over the hotplate. Flammable material could be ignited if brought in contact with a hot surface unit and may cause severe burns.

Take great care when heating fats and oils, as they will ignite if they get too hot.

Use a deep fat thermometer whenever possible to prevent overheating fat beyond the smoking point.

Never leave a chip pan unattended. Always heat fat slowly, and watch as it heats up. Deep fry pans should be only one third full of fat. Filling the pan too full of fat can cause a spill-over when food is added. If you use a combination of oils or fats in frying, stir them together before heating, or as the fats melt.

Foods for frying should be as dry as possible. Frost on frozen foods or moisture on fresh foods can cause hot fat to bubble up and over the sides of the pan. Carefully watch for spills or overheating of foods when frying at high or medium high temperatures. Never try to move a pan of hot fat, especially a deep fat fryer. Wait until the fat is cool.

When the grill is on, do not use the top of the flue (the slot along the back of the cooker) for warming plates, dishes, drying tea towels or softening butter.

When using an electrical appliance near the hotplate, be sure that the cord of the appliance does not come into contact with the hotplate.

Take care that no water seeps into the appliance.

Only certain types of glass, glass-ceramic, earthenware or other glazed containers are suitable for hotplate cooking; others may break because of the sudden change in temperature.

Do not allow anyone to climb, stand or hang on any part of the cooker.

Do not use aluminium foil to cover shelves, linings or the oven roof.

Never heat unopened food containers. Pressure build-up may make the container to burst and cause injury.

The cooker is designed for cooking foods only and must not be used for any other purpose.

The oven should NOT be used for heating the kitchen. This wastes fuel and the control knobs may become overheated.

When the oven is on DO NOT leave the oven door open for longer than necessary.

The specification of this cooker should not be altered.

This appliance is heavy, take care when moving it.

When the cooker is not in use, ensure that the control knobs are in the OFF position.

Installation

You must be aware of the following safety requirements and regulations.

Prior to installation, ensure that the local distribution conditions (nature of gas and gas pressure) and the adjustment of the appliance are compatible. See the appliance data badge.

This appliance shall be installed in accordance with the regulations in force and only in a well ventilated space. Read the instructions before installing or using this appliance.

In the UK - the regulations and standards are as follows:-

In your own interest and that of safety, it is law that all gas appliances be installed by competent persons. CORGI registered installers undertake to work to safe and satisfactory standards. Failure to install the appliance correctly could invalidate any warranty or liability claims and lead to prosecution. The cooker must be installed in accordance with:

- All relevant British Standards / Codes of Practice, in particular BS 5440 Part 2 2000,
- or Natural Gas - BS 6172 : 1990 and BS 6891 : 1998
- For LP Gas - BS 5482-1: 1994 (when the installation is a permanent dwelling), BS 5482-2: 1977, (when the installation is in a caravan or other non permanent dwelling), or BS 5482-3: 1999, (when the installation is in a boat).
- The Gas Safety (Installation and Use) regulations 1998.
- The relevant Building / IEE regulations.

In the Republic of Ireland, the installation must be carried out by a Competent Person and installed in accordance with the current edition of I.S. 813 "Domestic Gas Installations", the current Building Regulations and reference should be made to the current ETCI rules for electrical installation.

Provision of Ventilation

This appliance is not connected to a combustion products evacuation device. Particular attention shall be given to the relevant requirements regarding ventilation.

In the UK

The room containing the cooker should have an air supply in accordance with BS 5440 Part 2: 2000. All rooms require an openable window or equivalent, while some rooms require a permanent vent in addition to the openable window. The cooker should not be installed in a bedsitting room with volume less than 20m³. If it is installed in a room of volume less than 5m³ an air vent of effective area 100cm² is required; if it is installed in a room of volume between 5m³ and 10m³, an air vent of effective area 50cm² is required; while if the volume exceeds 11m³, no air vent is required.

If there are any other fuel burning appliances in the same room, BS 5440 Part 2 : 2000 should be consulted to determine the requisite air vent requirements.

In the Republic of Ireland

Reference should be made to the current edition of IS 813 which makes clear the conditions that must be met to demonstrate that sufficient ventilation is available.

Location of Cooker

The cooker may be installed in a kitchen/kitchen diner but NOT in a room containing a bath or shower.

NOTE:

An appliance for use on LPG shall not be installed in a room or internal space below ground level. e.g. in a basement.

All models are supplied set for use on either group H natural gas or for use on LP gas. See the appliance data badge.

This appliance is designed for domestic cooking only. Use for any other purpose could invalidate any warranty or liability claim.

Dear Installer

Before you start your installation, please complete the details BELOW.

If your customer has a problem relating to your installation they will be able to contact you easily.



Thank you

Installer's Name

Installer's Company

Installer's Telephone number

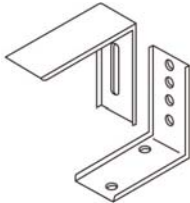
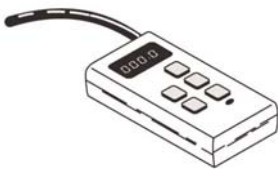
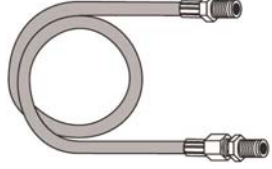
You will only need the following equipment to complete the cooker installation satisfactorily.

			
<p>STABILITY BRACKET</p> <p>If the cooker is to be supplied with gas through a flexible hose, a stability bracket or chain must be fitted.</p> <p>These are supplied not with the cooker but are available at most builders merchants.</p>	<p>GAS PRESSURE TESTER</p> <p>It is important the gas pressure is set correctly.</p>	<p>FLEXIBLE GAS HOSE</p> <p>Must be in accordance with the relevant standards. For LP Gas it should be suitable for LPG, capable of 50 mbar pressure, 70°C temperature rise and carry a red stripe, band or label.</p> <p>A hose is not supplied with the cooker.</p>	<p>MULTIMETER</p> <p>(for electrical checks)</p> <p>Make sure the installation is electrically safe.</p>

You will also need the following tools:

1. Electric drill
2. Masonry drill bit & rawplugs
(only required if fitting the cooker on a stone or concrete floor)
3. Steel tape measure
4. Cross head screwdriver
5. Flat head screwdriver
6. Spirit level
7. Pencil
8. Adjustable spanner
9. Screws for fitting stability bracket

Positioning the Cooker

The diagrams show the minimum recommended distance from the cooker to nearby surfaces.

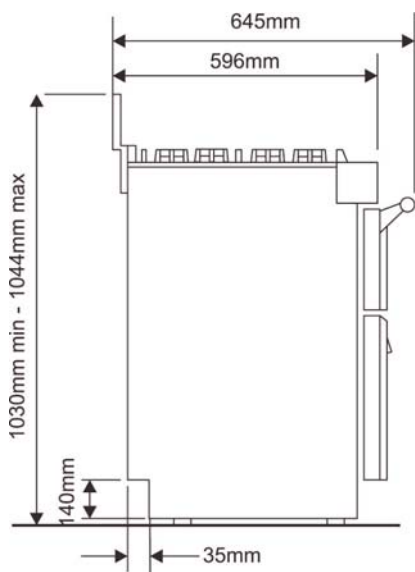
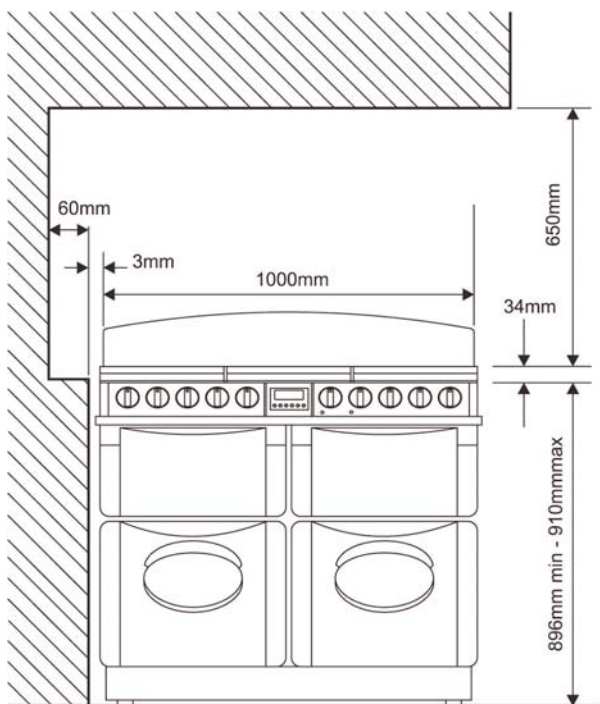

The hotplate surround should be level with, or above, any adjacent work surface. Above hotplate level a gap of 60mm should be left between each side of the cooker and any adjacent vertical surface.

For non-combustible surfaces (such as unpainted metal or ceramic tiles) this can be reduced to 25mm.

A minimum space of 650mm is required between the top of the hotplate and a horizontal combustible surface.

Any cooker hood should be installed in accordance with the hood manufacturers instructions.

Surfaces of furniture and walls at the sides and rear of the appliance should be heat, splash and steam resistant. Certain types of vinyl or laminate kitchen furniture are particularly prone to heat damage and discolouration. We cannot accept responsibility for damage caused by normal use of the cooker to any material that de-laminates or discolours at temperatures less than 65°C above room temperature.

For safety reasons curtains must not be fitted immediately behind the cooker.

We recommend a gap of 1006mm between units to allow for moving the cooker. Do not box the cooker in, it must be possible to move the cooker in and out for cleaning and servicing. The cooker should not be placed on a base.

Unpacking the Cooker

Do not take any packaging off the cooker until it is directly in front of the place it is to be installed (unless it will not fit through a door in its outer packaging).

Levelling

The Masterchef is designed to stand on a flat and level surface; however any unevenness maybe overcome by adjusting the four mobility wheels, one at each corner of the base plate. The adjusting screws are accessed by removing the plinth (two screws).

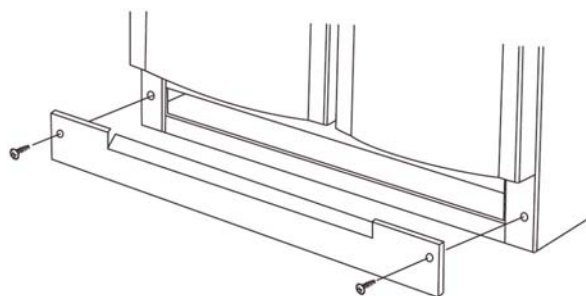

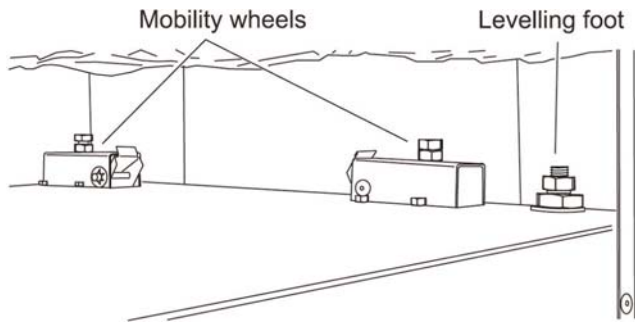

To raise the cooker turn screw clockwise, to lower turn screw anti-clockwise.

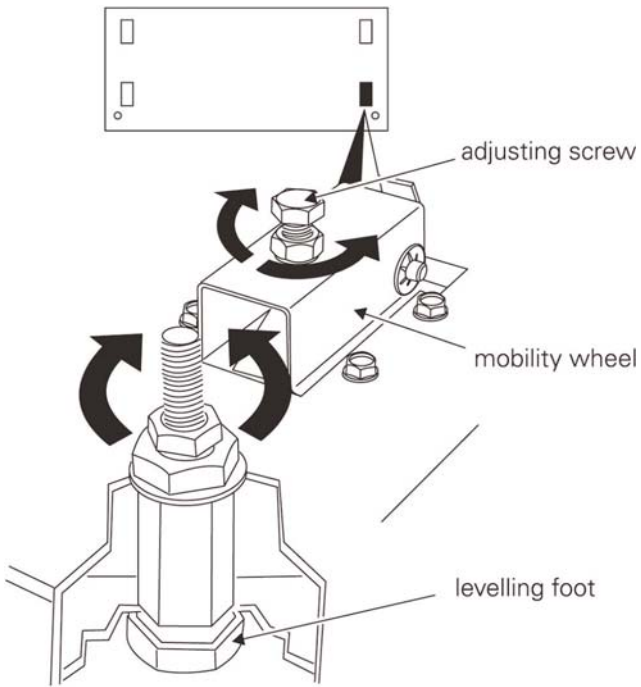

When the cooker is level and in the correct position, the two feet at the front corners of the cooker **MUST** be lowered to come into contact with the floor and support the cooker (tighten the locknuts). The two front mobility wheels must then be raised by at least one turn (anti-clockwise of the adjusting screw) to ensure that the cooker is locked in place and cannot accidentally roll out of position.

Fitting the splashback (optional)

To fit the splashback, the appliance must be moved out slightly to gain access to the rear of the appliance.

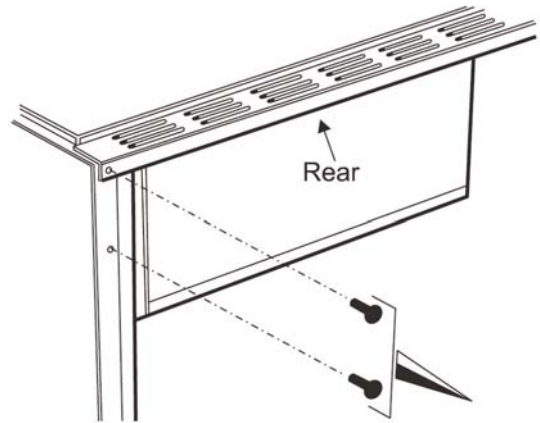

Remove 4 screws as shown.

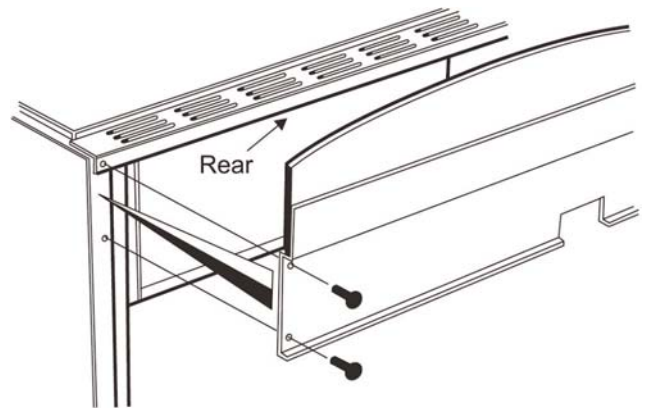

Fit new splashback as shown.

Gas Connection

Fitting a stability bracket

A stability bracket or chain (not supplied with the cooker) should be fitted when the cooker is connected to a flexible gas supply. Any restraining device should be secured to the fabric of the building and should be able to be released so that the cooker can be pulled out for cleaning and maintenance.

When fitting a stability bracket read these instructions together with the leaflet supplied with the bracket.

- Position and level the appliance.
- Draw a pencil line along the front edge of the base of the cooker and along the right hand edge.
- Remove the range.
- Mark off 495mm from the RH side of the unit to indicate the centre line for the bracket.
- Mark off 415mm to locate the front edge of the lower bracket. Fix bracket to floor.
- Measure the height from floor level to the bottom of the opening in the cooker back. Add 3mm to this dimension and assemble the stability bracket to this height (i.e. from floor level to underside of top member).

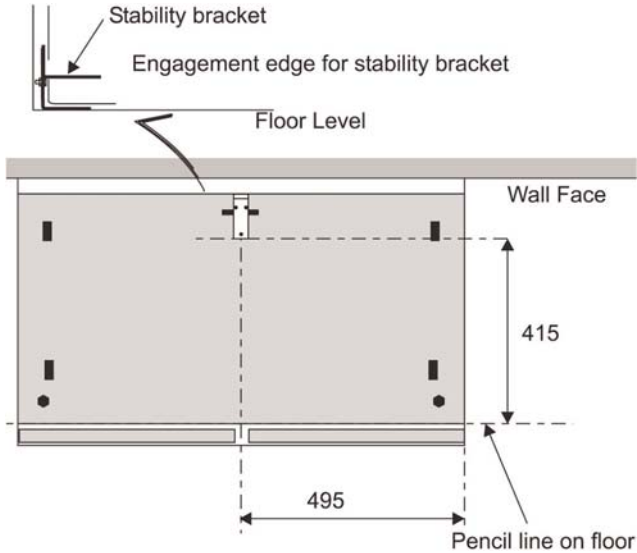

Gas Connection

The gas supply need to terminate with a down facing bayonet. The rear cover boxes limit the position of the supply point.

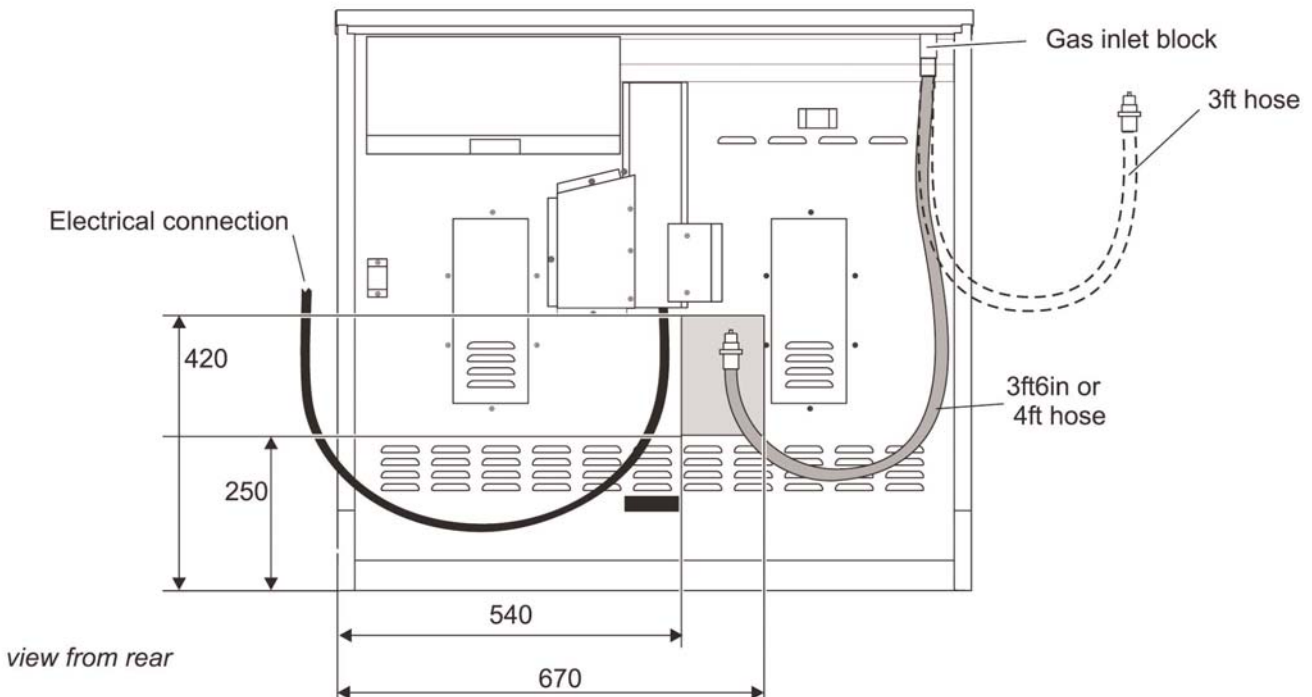
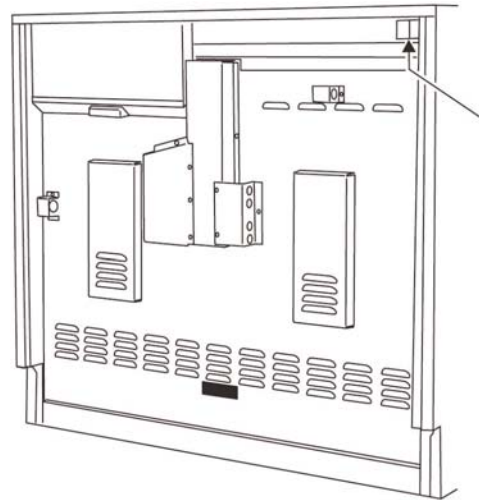

Because the height of the cooker can be adjusted and each connection is different it is difficult to give precise dimensions. Ideally the house supply bayonet should be in the shaded area shown in the diagram. This hose should be fitted so that both inlet and outlet connections are vertical so that the hose hangs downwards in a 'U' shape. A 3ft hose will need to be connected from the side.

For Natural Gas the flexible hose must be in accordance with B.S. 689.

For LP Gas it should be capable of 50mbar pressure, 70°C temperature rise and carry a red stripe, band or label.

If in doubt contact your supplier.

Screw connect the threaded end of the hose into the gas inlet in the underside of the connector block on the back of the cooker.

After completing the gas connection, check the cooker is gas sound with a pressure test. When checking for gas leaks do not use washing up liquid - this can corrode. Use a product specifically manufactured for leak detection.

Pressure Testing

The gas pressure can be measured at the fish kettle burner jet. Make sure that the cooker is not connected to the electricity supply. Lift off the burner head. Fit the pressure gauge to the jet. Turn on one of the other burners and light it with a match. Turn on the control for the fish kettle burner and press in the knob to allow the gas through and register the pressure on the gauge.

For Natural gas cookers the pressure should be 20mbar.

For LP gas (propane) the pressure should be 37mbar.

Re-assemble burner top, making sure it is re-assembled in the correct way on the burner body.

Electrical Connection

This appliance must be installed by a qualified electrician to comply with the relevant regulations and also the local electricity supply company requirements.

WARNING: THIS APPLIANCE MUST BE EARTHED.

NOTE: The cooker must be connected to the correct electrical supply as stated on the voltage label on the cooker, through a suitable cooker control unit incorporating a double pole switch having a contact separation of at least 3mm in all poles. This cooker must not be connected to an ordinary domestic power point.

The total electrical load of the appliance is approximately 8.8 kW. The cable size used should be suitable for this load and comply with all local requirements.

Access to the mains terminal is gained by removing the electrical terminal cover box on the back panel.

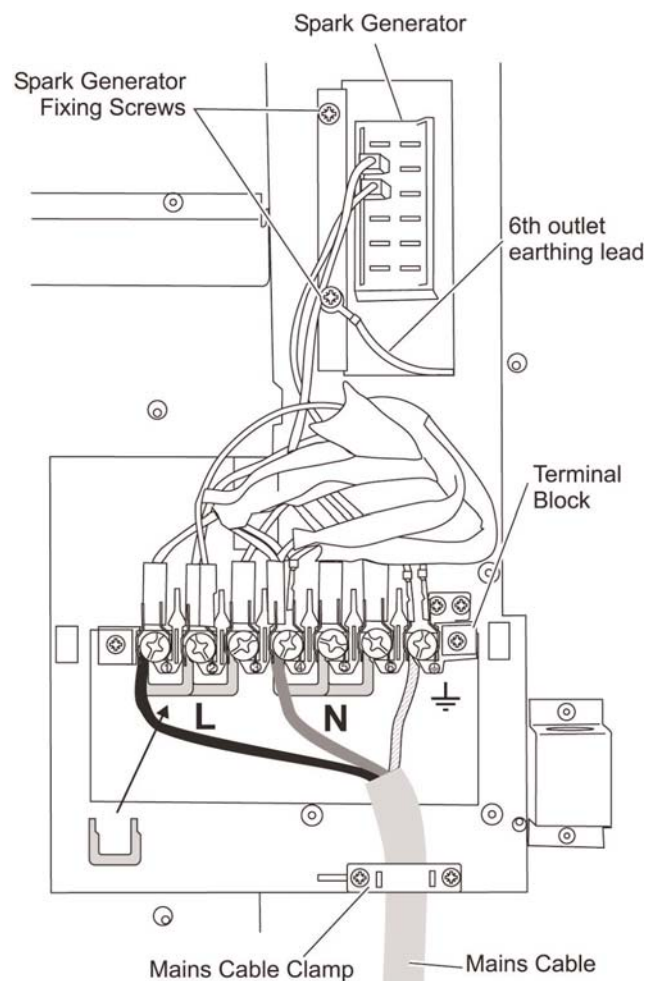

Connect the mains cable to the correct terminals for your electrical supply type.

SERVICING - WARNING

Disconnect from electricity and gas before servicing. Check appliance is safe when you have finished

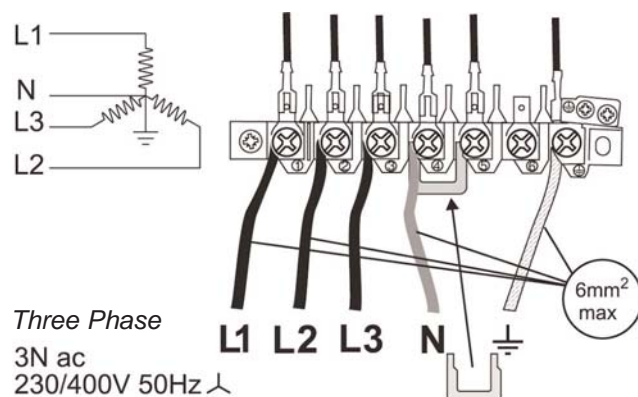
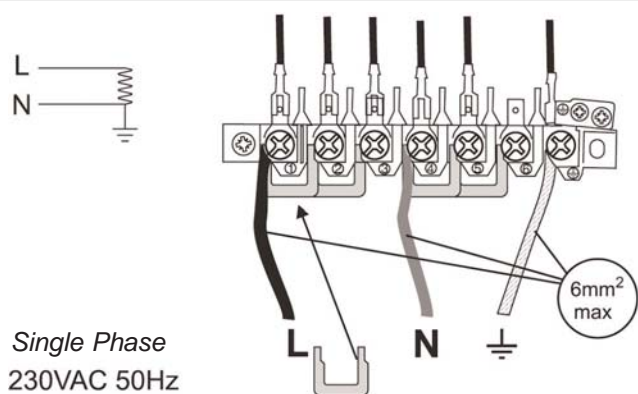

Grill

Open the grill compartment door. Turn on the grill control and check that the grill heats up.

Oven Check

Turn on the ovens and check that they start to heat up. Turn off the ovens.

Fitting the plinth

Remove the 2 screws along the front bottom edge of the cooker. Hold the plinth in place and refit the 2 screws.

Customer care

Please inform the user how to operate the cooker and hand over these instructions.

Thank you.

Check that the links are correctly fitted and that the terminal screws are tight. Secure the mains cable using the cable clamp.

Current Operated Earth Leakage Breakers

Where the installation is protected by a 30-milliamp sensitivity residual current device (RCD), the combined use of your cooker and other domestic appliances may occasionally cause nuisance tripping. In these instances the cooker circuit may need to be protected by fitting a 100mA device. This work should be carried out by a qualified electrician.

Hotplate

Check each burner in turn. There is a flame safety device that stops the flow of gas to the burner if the flame goes out. There is also a spark ignition system that works when the knob is pressed in.

For each burner, push in and turn the knob to the large flame symbol (●).

The igniter should spark and light the gas. Keep holding the knob pressed in to let the gas through to the burner for a few seconds.

If, when you let go of the control knob, the burner goes out, the safety device has not held in. Turn the control to the off position and wait one minute, then try again this time holding in the control knob for slightly longer.

SERVICING - WARNING

Disconnect from electricity and gas before servicing. Check appliance is safe when you have finished

Servicing

When servicing or replacing gas carrying components disconnect from the gas supply before commencing operation.

Check the appliance is gas sound after completion of service. When checking for gas leaks do not use washing up liquid - this can corrode. Use a product specifically manufactured for leak detection.

CAUTION: DO NOT USE A FLAME TO CHECK FOR GAS LEAKS.

Do not use re-conditioned or un-authorized gas controls.

Disconnect from the electricity supply before commencing servicing, particularly before removing any of the following:- control panel, side panels, hotplate tray or any electrical components or covers.

Before electrical re-connection, check that the appliance is electrically safe.

NOTE: References to LH and RH oven apply as viewed from the front.

BEFORE SERVICING ANY GAS CARRYING COMPONENTS, TURN OFF THE GAS SUPPLY.

A. To Remove Hotplate

1. Isolate from electric supply.
2. Remove pan supports and burner caps.
3. Remove burner fixing screws (14) and hotplate fixing screws (4).
4. Lift off hotplate taking care to lift clear of burner electrodes.
5. Re-assemble in reverse order.

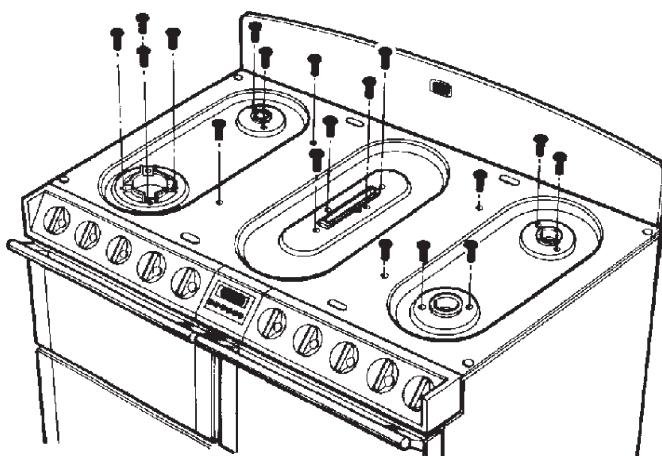

B. To Remove Side Panels

1. Isolate from electric supply.
2. Lower front mobility wheels see section 'MOBILITY WHEELS' in the users instructions.

NOTE: It may be necessary to disconnect the flexible gas connection to allow the cooker to be withdrawn from between the kitchen units.

3. Remove fixing screws and lift off side panel.
4. Re-assemble in reverse order.

C. To Remove Facia Castings

1. Isolate from electric supply.
2. Proceed as 'TO REMOVE HOTPLATE'.
3. Proceed as 'TO REMOVE SIDE PANELS'.
4. Pull off control knobs.
5. Remove control panel fixing screws 5 per casting (see fig. below). When removing screws supporting casting when removing screws.

NOTE: When removing RH casting the oven indicator neons require disconnecting from the facia, hold the cables at their entry into the neon twist and pull, this will disengage the neon assembly.

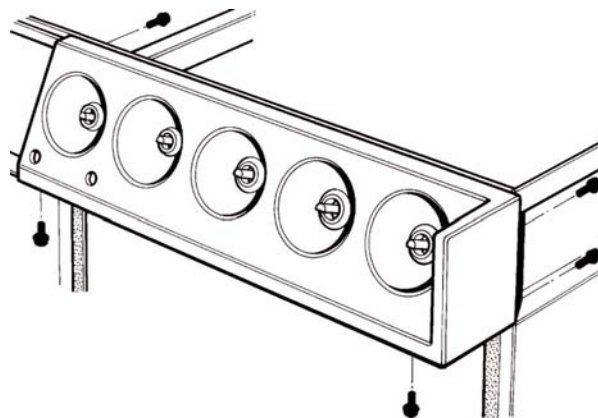

D. To Remove Timer

1. Isolate from electric supply.
2. Open top oven and grill doors to gain access to timer facia fixing screw and remove screw.
3. The timer assembly can now be hinged upwards sufficiently to disconnect electric cables at rear of timer.

NOTE: Take care to identify cable connections.

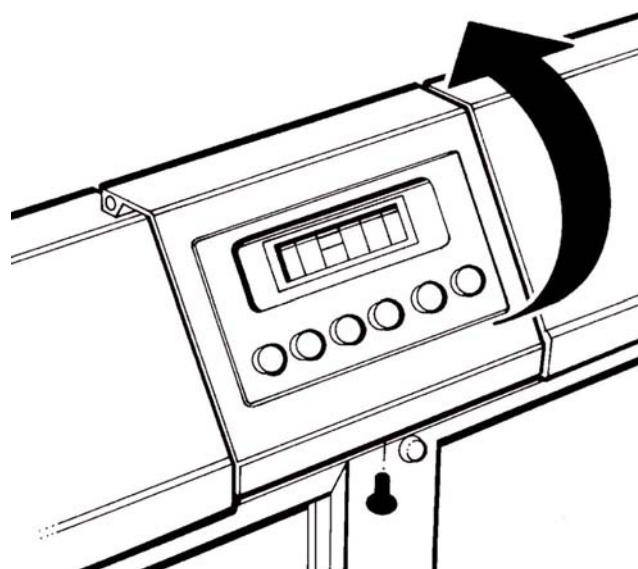

SERVICING - WARNING

Disconnect from electricity and gas before servicing. Check appliance is safe when you have finished

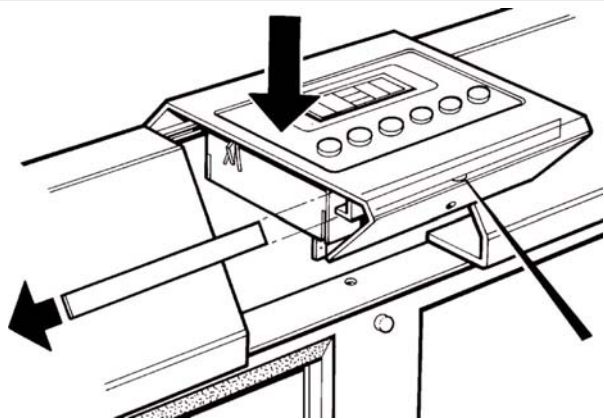

4. Slacken timer fixing screw sufficiently to allow timer securing strip to slide out of fascia panel.
5. Re-assemble in reverse order.

E. To Remove Gas Taps/Ignition Switches

1. Isolate from electric supply.
2. Proceed as 'TO REMOVE HOTPLATE'.
3. Proceed as 'TO REMOVE SIDE PANEL'.
4. Undo burner gas pipe to tap (15mm nuts).
5. Remove two screws securing tap to gas rail.
6. Withdraw gas tap from gas rail taking care not to strain ignition switch cables.
7. Disconnect ignition switch cables and slide off switch activating collar from spindle of tap.
8. Re-assemble in reverse order.

NOTE: Always fit new 'O' ring seal and check for gas soundness.

F. To Remove Grill Regulator/Light Switch

1. Isolate from electric supply.
2. Proceed as 'TO REMOVE FACIA CASTINGS'.
3. Remove two screws securing control to control mounting panel.
4. Withdraw control and cables taking care not to strain the cables.
5. Disconnect cables from the control.
NOTE: Take care to identify terminations.
6. Re-assemble in reverse order.

G. To Remove Oven Thermostats

1. Isolate from electric supply.
2. Proceed as 'TO REMOVE GRILL REGULATOR'.
3. Remove (10) back panel screws.
4. Remove thermostat phial and capillary through back of cooker, note correct capillary route.
5. Re-assemble in reverse order.

H. To Remove Spark Generator

1. Isolate from electric supply.
2. Lower front mobility wheels (see section 'MOBILITY WHEELS' in Users Instructions) and pull cooker forwards to gain access to the rear of the cooker.
CAUTION: DO NOT STRAIN FLEXIBLE GAS CONNECTION disconnect if necessary.
3. Remove mains cable inlet cover, 8 screws.
4. Disconnect electric cables to generator.
5. Remove two screws securing generator mounting bracket to cooker frame and carefully withdraw generator sufficiently to disconnect electrode leads.
6. Re-assemble in reverse order.

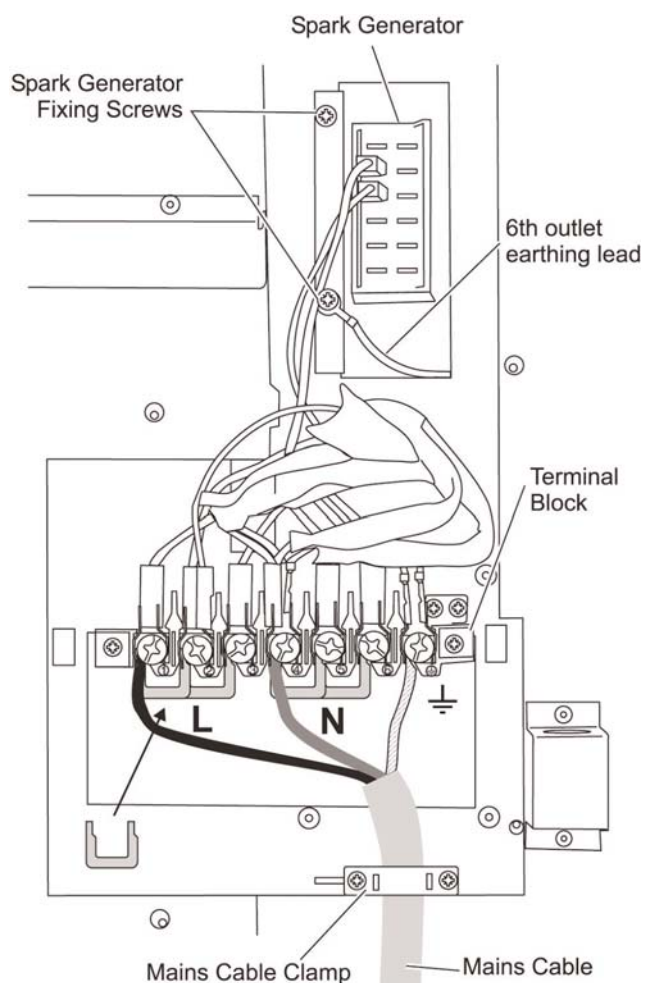

SERVICING - WARNING

Disconnect from electricity and gas before servicing. Check appliance is safe when you have finished

I. To Remove Electrode

1. Isolate from electric supply.
2. Proceed as 'TO REMOVE SPARK GENERATOR' disconnect the appropriate electrode lead.
3. Proceed as 'TO REMOVE THE HOTPLATE'.
4. Withdraw clip securing electrode to burner and withdraw lead and electrode (see fig. below).
5. Re-assemble in reverse order.

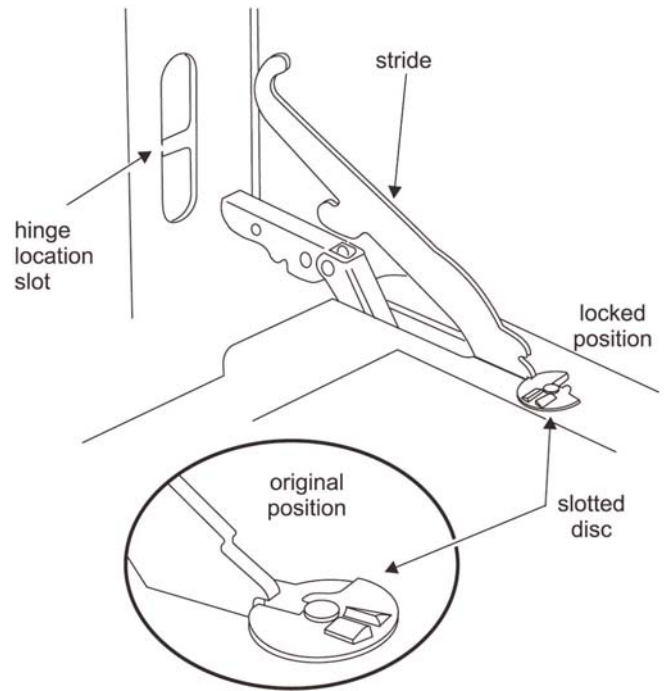
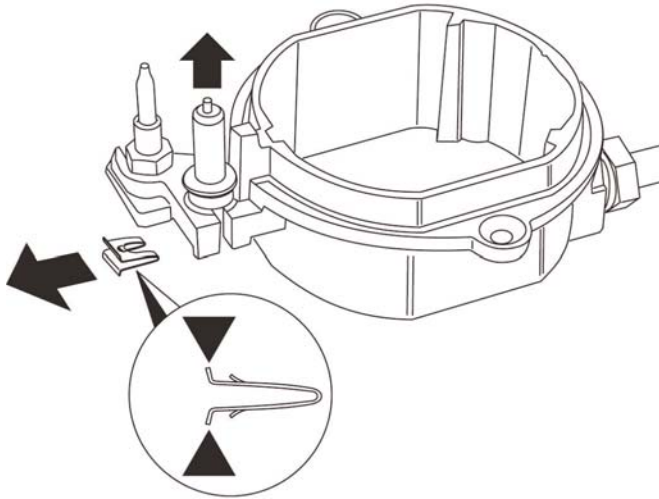

J. To Remove Grill Element

1. Isolate from electric supply.
2. Remove two screws securing grill pelmet and remove pelmet.
3. Remove two screws securing grill element fixing to carrier to grill cavity and allow element and carrier to hinge down from the rear.
4. The element can now be lifted out of the carrier to allow access to the electric terminals at the rear.
5. Disconnect the terminals taking note of their termination sequence and routing to avoid trapping cables during re-assembly.
6. Re-assemble in reverse order.

K. To Remove Doors

1. Open door fully.
2. Rotate hinge locking disc 90° clockwise on both door hinges to lock door in open position.
3. Carefully close door and at approximately half closed the hinges will release themselves from the cooker frame.
4. Re-assemble in reverse order.

L. To Remove Oven Door Seal

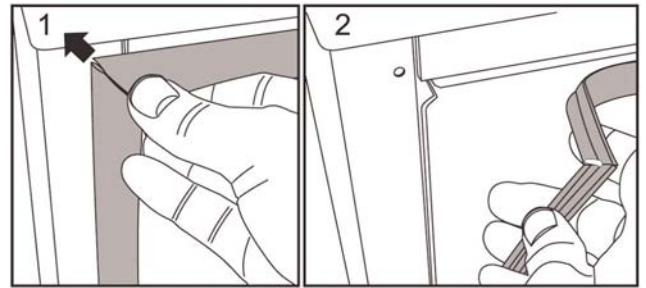

1. Open oven door. The seal is held in place by small hooks on the rear face. At the corner pull seal diagonally away from the door centre until the hook is released.
2. Proceed to the next hook and release it in a similar way, and so on. Use force if the hooks are stiff, as the old seal will be discarded.
3. Hook the new seal in one of the corner holes of the door and proceed round the door opening snapping each hook in turn.

SERVICING - WARNING

Disconnect from electricity and gas before servicing. Check appliance is safe when you have finished

M. To Remove Upper Door/Grill Liners

1. Proceed as 'TO REMOVE DOORS'.
2. Remove door seal (upper oven only) by unhooking from the front frame at the four corners.
3. Remove LH and RH shelf runners (2 screws per runner). The liners can now be withdrawn. Also remove 4 top fixing screws.

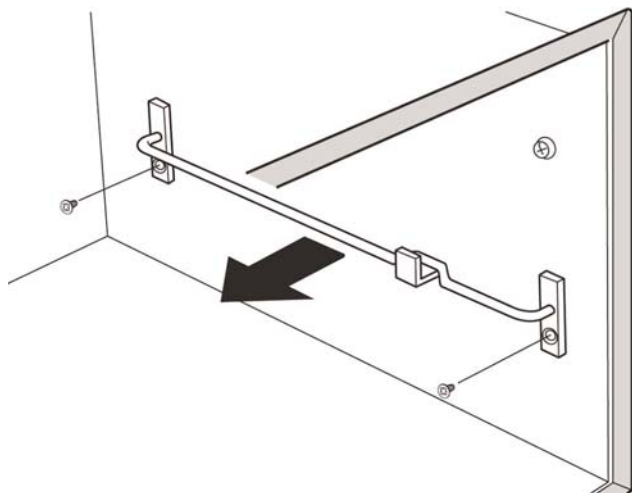

N. To Remove Lower Oven Liners

1. Proceed as 'TO REMOVE DOORS'.
2. Remove door seal by unhooking from its four corners.
3. Remove screws securing shelf runners (4 each side).
4. Remove rear liner 4 screws.
5. Remove rear liner mounting brackets 2 screws each side.
6. Whilst supporting the roof liner remove side linings and roof liner.
7. Re-assemble in reverse order.

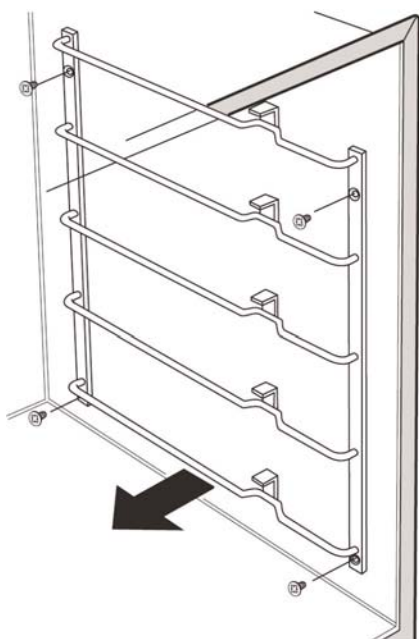

O. To Remove Upper Oven Elements

1. Isolate from electric supply.
2. Proceed as 'TO REMOVE UPPER OVEN LINERS'.
3. Lift out oven base to gain access to the oven element.
4. Remove screw securing element to frame.
5. Carefully withdraw element from frame so that the electric terminals can be disconnected, take care not to allow the cables to drop down the back of the appliance.

P. To Remove Fan Oven Element

1. Isolate from electric supply.
2. Proceed as 'TO REMOVE OVEN LINERS'.

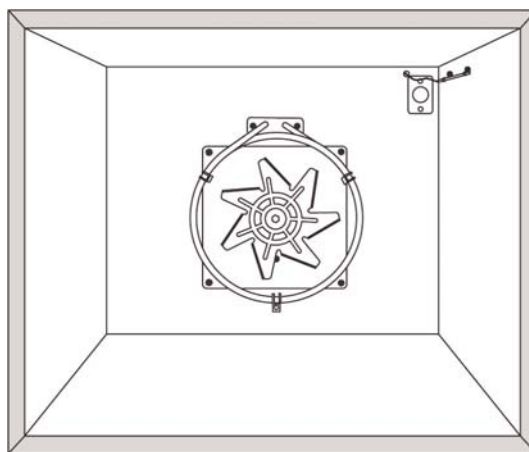

3. Remove 3 screws securing element to frame and carefully withdraw element until access can be made to the electrical terminals.
4. Disconnect terminals taking care not to allow the cable to fall down the rear of the appliance.
5. Re-assemble in reverse order.

Q. To Remove Oven Fan

1. Isolate from electric supply.
2. Proceed as 'TO REMOVE OVEN ELEMENT'.
3. Remove 4 fixing screws securing fan assembly to frame.
4. Withdraw fan assembly sufficiently to gain access to motor electrical terminals and disconnect cables.
5. Remove fan blade.
NOTE: Fan blade fixing nuts is LH thread.
6. Remove motor from mounting plate screws.
7. Re-assemble in reverse order.

SERVICING - WARNING

Disconnect from electricity and gas before servicing. Check appliance is safe when you have finished

R. To Remove Oven Fan

1. Isolate from electric supply.
2. Proceed as 'TO REMOVE OVEN ELEMENT'.
3. Remove 4 fixing screws securing fan assembly to frame.
4. Withdraw fan assembly sufficiently to gain access to motor electrical terminals and disconnect cables.
5. Remove fan blade.
NOTE: Fan blade fixing nuts is LH thread.
6. Remove motor from mounting plate screws.
7. Re-assemble in reverse order.

S. To Remove Door Liners/Door Handles/Door Glass

1. Proceed as 'TO REMOVE DOORS'.
2. Remove liner fixing screws (4 screws upper oven door, (6 screws lower oven door).
3. Access can now made to fixing screws of the hinges, door glass and handle.
4. Re-assemble in reverse order.

T. To Remove Oven Lamp

1. Isolate from electric supply.
2. Proceed as 'TO REMOVE TOP OVEN/GRILL LINERS'.
3. Remove door seal if necessary by unhooking from the four corners.
4. Lift out base panel to gain access to lamp electrical terminals and disconnect cables.
5. Remove lamp lens.
6. The lamp body can now be removed by depressing four retaining tags on the lamp body.
7. Re-assemble in reverse order.

U. To Remove Spark Generator

1. Isolate from electric supply.
2. Lower front mobility wheels (See section 'MOBILITY WHEELS' in Users Instructions) and pull cooker forward to gain access to the rear of the cooker.
CAUTION: DO NOT STRAIN FLEXIBLE GAS CONNECTION disconnect if necessary.
3. Remove mains cable inlet cover, 8 screws.
4. Disconnect electric cables to generator.
5. Remove two screws securing generator mounting bracket to cooker frame and carefully withdraw generator sufficiently to disconnect electrode leads.
6. Re-assemble in reverse order.

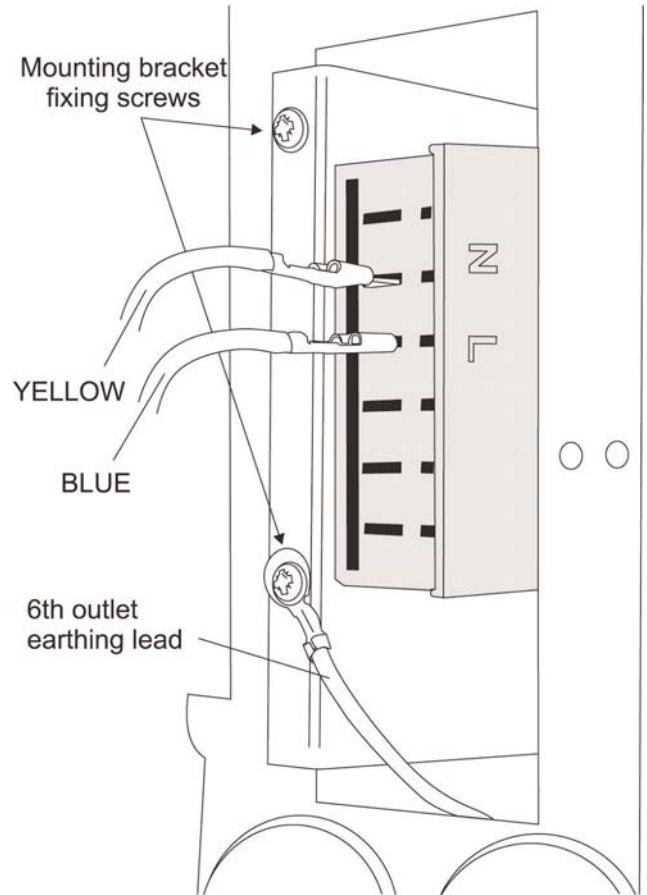

SERVICING - WARNING

Disconnect from electricity and gas before servicing. Check appliance is safe when you have finished

Circuit Diagram

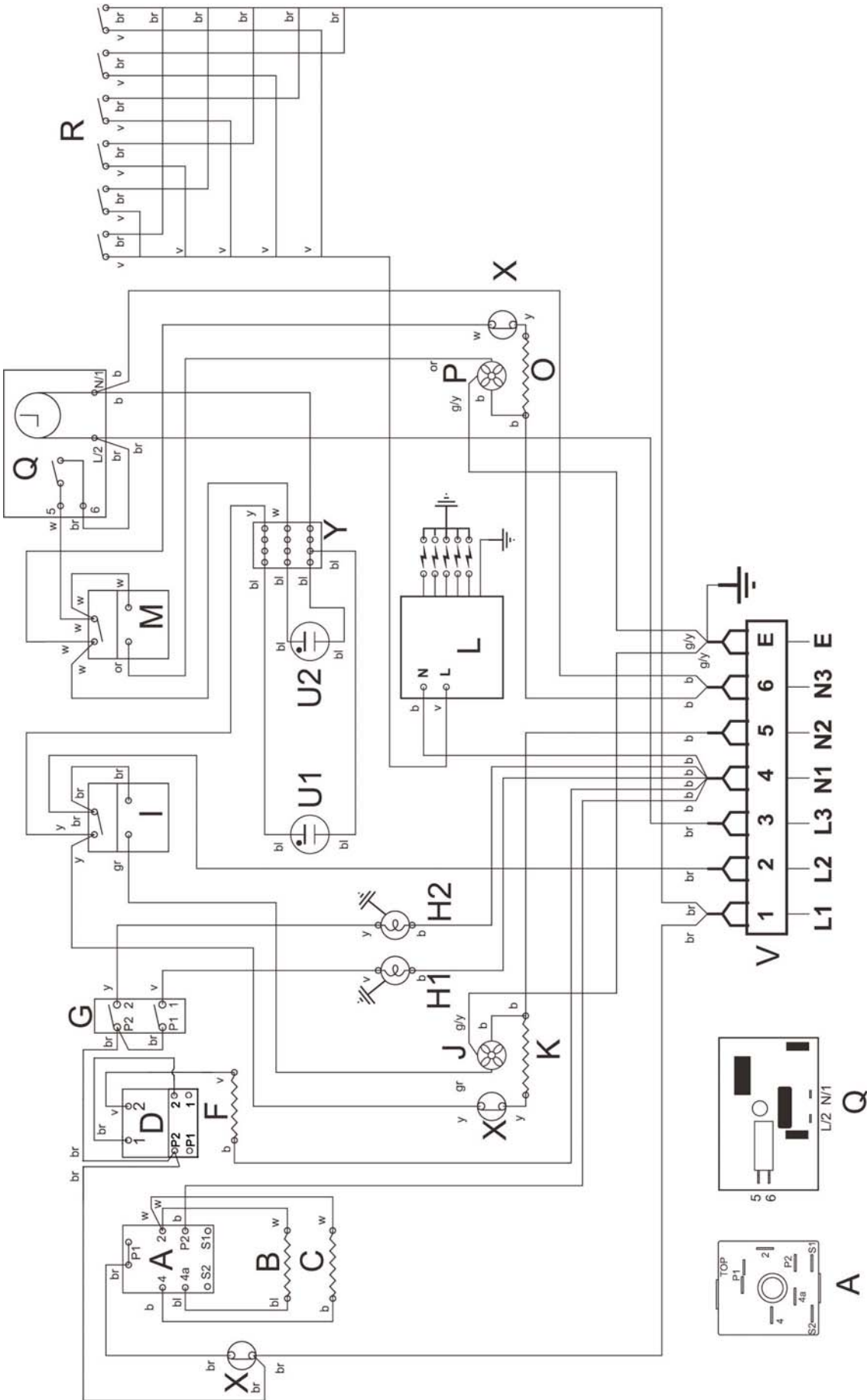

SERVICING - WARNING

Disconnect from electricity and gas before servicing. Check appliance is safe when you have finished

	Colour Code
A Grill energy regulator	b Blue
B Outer grill element	bl Black
C Inner grill element	br Brown
D Slow cooking oven thermostat	gr Grey
F Slow cooking oven element	g/y Green/Yellow
G Oven light switches	or Orange
H1 Right hand oven light	v Violet
H2 Left hand oven light	w White
M Left hand oven thermostat	y Yellow
O Left hand oven element	
P Left hand oven fan	
I Right hand oven thermostat	
J Right hand oven fan	
K Right hand oven element	
Q Clock	
R Ignition switches	
S Spark generator	
T Terminal	
U1 Right hand oven neon	
U2 Left hand oven neon	
Y Mains terminal	
X Cut out	

SERVICING - WARNING

Disconnect from electricity and gas before servicing. Check appliance is safe when you have finished

Technical Data

This cooker is category II_{2H3P}

It is supplied for either group H natural gas or for Propane gas - check the appliance data badge.

INSTALLER: Please leave these instructions with the User.

DATA BADGE LOCATION: Behind plinth panel, serial number repeater badge below right hand oven opening.

Country of Destination: GB/IE

Gas		Electric
Natural Gas	20mbar	220 - 240V 50Hz
Propane	37mbar	

(See appliance data badge for test pressures)

Dimensions

Overall height	minimum 915mm	maximum 940mm
Overall width	1000mm See 'Positioning of Cooker'	
Overall depth including handles	660mm	
Overall depth excluding handles	600mm	
Space for fixing	See 'Positioning of Cooker'	
Minimum space above hotplate	800mm	

Connections

Gas	Electric
Rp 1/2 at rear right-hand side	220 - 240V 50Hz

Ratings

Hotplate	Natural Gas			Propane Gas		
	Input	Injector	Bypass	Input	Injector	Bypass
Left hand front wok	3.5 kW	130	96	3.5 kW (250g/h)	95	57
Right hand front Rapide	3.0 kW	116	54	3.0 kW (214g/h)	85	40
Rear Semi-Rapide	1.75 kW	097	39	1.75 kW (125g/h)	65	32
Centre Fish Burner	2.6 kW	108	70	2.6 kW (186g/h)	80	47

Gas burner inputs based on Gross Calorific Value

Fan Ovens	Forced air convection
	2.5 kW
Energy efficiency class on a scale of A (more efficient) to G (less efficient)	C
Energy Consumption based on a standard load	1.05 kWh
Usable Volume (litres)	49
Size	Medium
Time to cook standard load	50 minutes
Surface area of the grid	720cm ²

Grill	2.5kW
Slow cooking oven	1.2kW

Maximum total electrical load at 230V 8.5 kW (approximate total including oven lights, etc.)

For further advice or information contact your local distributor/stockist

With Aga's policy of continuous product improvement, the Company reserves the right to change specifications and make modifications to the appliance described and illustrated at any time.



Manufactured By
Aga
Station Road
Ketley Telford
Shropshire TF1 5AQ
England

www.aga-web.co.uk
www.agacookshop.co.uk
www.agalinks.com