

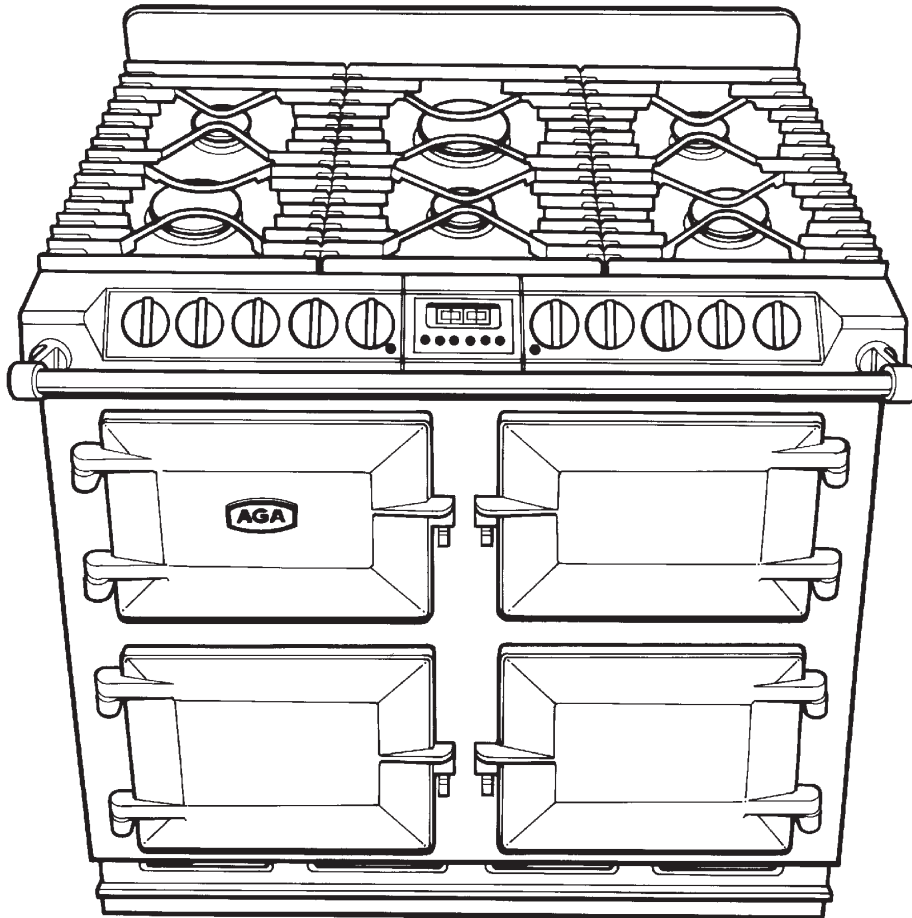

AGA SIX-FOUR SERIES - DC6 (FFD) OWNERS MANUAL - NATURAL GAS



DESN 512387 A

Comprising Servicing, Installation & Users Instructions & Cooking Guide

Remember, when replacing a part on this appliance, use only spare parts that you can be assured conform to the safety and performance specification that we require. Do not use reconditioned or copy parts that have not been clearly authorised by AGA.

PLEASE READ THESE INSTRUCTIONS BEFORE USING THIS APPLIANCE

CE For use in GB and IE

11/11 EINS 512335

CONTENTS

SECTION	PAGE
INSTALLATION SECTION	3
INSTALLATION	4
TECHNICAL DATA	5
FITTING AND PRODUCT DIMENSIONS	6
ELECTRICAL CONNECTION	7-8
CONNECTING TO GAS	9-11
PRESSURE TESTING	11
LEVELLING AND MOBILITY WHEELS	12
FITTING OF HOTPLATE CASTINGS AND PAN SUPPORTS	13-17
SPLASHBACK	17
USERS GUIDE	18
GENERAL INFORMATION	19
HEALTH AND SAFETY	20
PRODUCT VIEW	21
CONTROL PANEL	22
GAS HOTPLATE	23-24
TO FIT PAN SUPPORTS	25
SETTING UP THE COOKER FOR USE	26
GRIDDLE PLATE	27
SIMMERING OVEN	28
SIMMERING OVEN RECIPES	29-32
THE GRILL	33
THE OVENS	34
OVEN COOKING GUIDE	35-39
THE MINUTE TIMER	40
AUTOMATIC COOKING CONTROL	41-42
CLEANING AND CARING FOR YOUR COOKER	42-47
SERVICING SECTION	48
SERVICING	49-58
WIRING DIAGRAM	59

Installation

Section

Remember, when replacing a part on this appliance, use only spare parts that you can be assured conform to the safety and performance specification that we require. Do not use reconditioned or copy parts that have not been clearly authorised by AGA.

INSTALLATION

WARNING: THIS APPLIANCE SHALL BE INSTALLED IN ACCORDANCE WITH THE REGULATIONS IN FORCE AND ONLY USED IN A WELL VENTILATED SPACE, READ THE INSTRUCTIONS BEFORE INSTALLING OR USING THIS APPLIANCE.

PRIOR TO INSTALLATION, ENSURE THAT THE LOCAL DISTRIBUTION CONDITIONS (TYPE OF GAS AND GAS PRESSURE) AND THE ADJUSTMENTS OF THE APPLIANCE ARE COMPATIBLE.

THE ADJUSTMENT CONDITIONS FOR THIS APPLIANCE ARE STATED ON THE DATA PLATE WHICH IS SITUATED IN THE RIGHT HAND VENT SLOT AT THE BASE OF THE APPLIANCE.

This appliance is not connected to a combustion products evacuation device. It must be installed and connected in accordance with current installation regulations. Particular attention shall be given to the relevant requirements regarding ventilation. (B.S. 5440 Part 2). It should be in accordance also with any relevant requirements of the Gas Region and Local Authority.

In your own interest, and that of safety to comply with the law, all gas appliances must be installed by a competent person. Failure to install appliances correctly could lead to prosecution.

On completion, test the gas installation for soundness.

WARNING: THIS APPLIANCE MUST BE EARTHED.

The appliance is designed for the voltage stated on the data plate.

The DC6 is supplied from the manufacturers as a fully tested chassis construction. Hot plate, doors, splashback, pan supports and handrail are assembled during installation.

TECHNICAL DATA

HOTPLATE

NATURAL GAS G20 - (APPLIANCE CATEGORY I_{2H})

	L.H.F. WOK	R.H.F.	R.H.R.	L.H.R.	CENTRE FRONT	CENTRE REAR
BURNER TYPE	ULTRA-RAPID	RAPID	RAPID	SEMI-RAPID	SEMI-RAPID	ULTRA-RAPID
MAXIMUM HEAT INPUT	4.5 kW	3.0 kW	3.0 kW	1.75 kW	1.75 kW	5.0 kW
INJECTOR MARKING						
MAIN	0.66	116	116	097	097	167
SECONDARY	1.00 (x2)	-	-	-	-	-

PRESSURE POINT POSITION: REAR RH SIDE OF HOTPLATE

PRESSURE SETTING: 20mbar

BURNER IGNITION: H.T. SPARK

ELECTRIC GRILL AND OVENS

TOP OVEN POWER RATING - 1.45 kW

GRILL ELEMENT - POWER RATING 2.25kW

SLOW COOKING OVEN - POWER RATING 0.9kW

LOWER OVEN (FAN) - 2.0kW

230V 30 AMP POWER SUPPLY

This is a CLASS 1, type X appliance.

The data plaque is located on a pull out plate - lower front of appliance (See Fig. 10, Page 21).

FITTING AND PRODUCT DIMENSIONS

Any side wall above the cooker on either side shall be not less than 60mm horizontally from the cooker (Fig. 1).

Surfaces over the top of the cooker must not be closer than 650mm.

A minimum clearance of 1000mm must be available at the front of the cooker to enable it to be serviced.

The vent slots in the back of the top plate must not be obstructed.

The cooker must stand on a firm and level surface we recommend that any soft material such as linoleum is removed.

PLEASE NOTE WHEN FITTING A COOKER HOOD

If a cooker hood is to be fitted, we only recommend the 6-4 Series CH900 cooker hood. It must be installed at a height of at least 800mm above the hotplate.

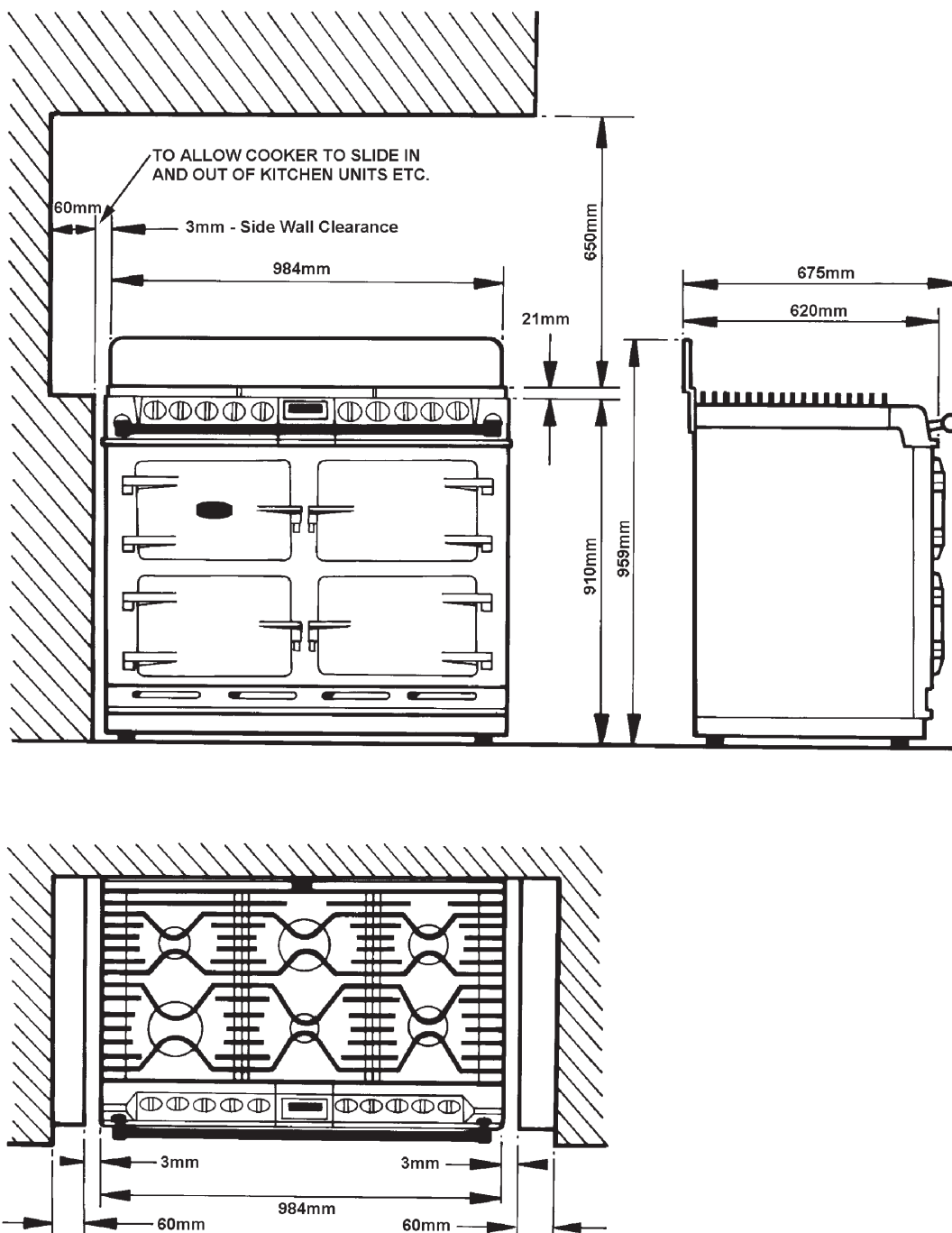

Fig. 1

ELECTRICAL CONNECTION

ELECTRICAL CONNECTION IS LOCATED AT THE TOP RIGHT HAND SIDE OF THE APPLIANCE, BEHIND SIDE PANEL. DURING INSTALLATION REMOVE THE RIGHT HAND SIDE PANEL TO CONNECT ELECTRICAL SUPPLY.

Remove 6 screws securing side panel to gain access to mains terminal. See Fig. 3 for location of cover.

Remember that the mains electrical cable must be routed through the grommet at the rear right hand side of the cooker near the top, before connecting to the mains terminal connection.

REFER TO FIG. 2 for wire connection to appliance.

Remember that an excess of cable length is required inside the cooker to allow for possible servicing of the spark generator.

Remember that an excess of cable length is required behind the cooker for the withdrawal of the cooker from between the kitchen units etc.

SINGLE PHASE CONNECTION - The cooker requires a 30amp power supply fitted in conjunction with a Double Pole Isolator with a minimum contact clearance of 3mm and be connected to the mains with a minimum 6mm² cable to comply with the latest editions of the Local and National Wiring Regulations.

THE ISOLATOR **MUST NOT** BE POSITIONED IMMEDIATELY ABOVE THE COOKER, BUT **MUST** BE SITED WITHIN 2 METRES OF THE APPLIANCE.

Replace the right hand side panel once electrical connection has been made and replace fixing screws.

NOTE: Ensure that the insulation card covering the mains terminal is in place, between the side panel and mains terminal.

SINGLE PHASE CONNECTION - MINIMUM 6mm² CABLE AND MUST COMPLY WITH THE LATEST EDITIONS OF LOCAL AND NATIONAL WIRING REGULATIONS.

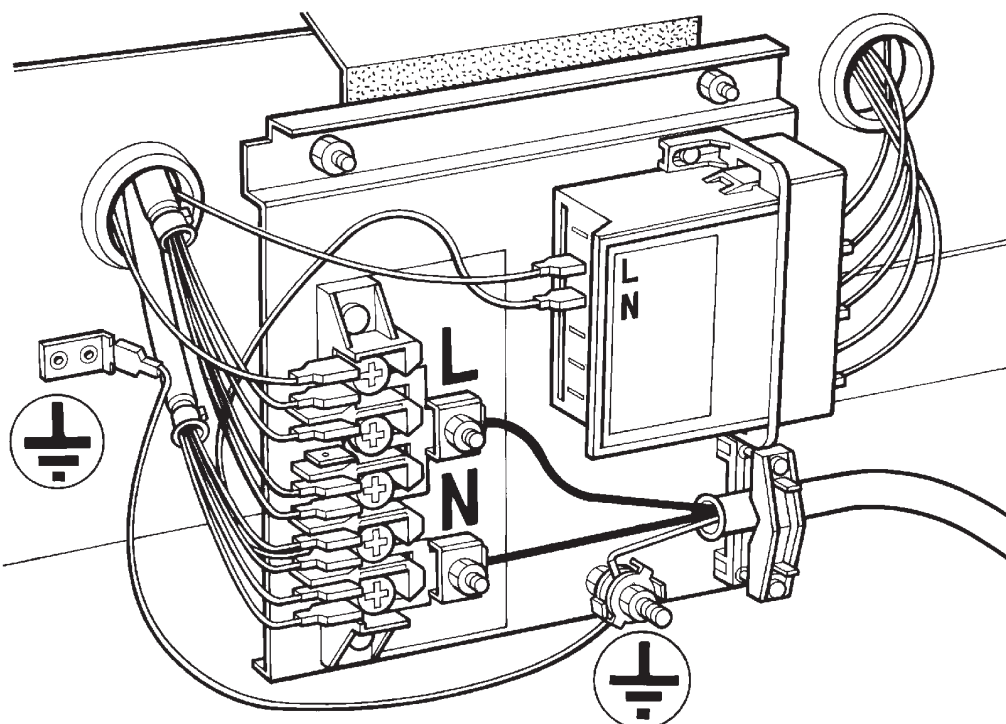

Fig. 2a

DESN 513312

THREE PHASE CONNECTION - MINIMUM 2.5mm² CABLE AND MUST COMPLY WITH THE LATEST EDITIONS OF THE LOCAL AND NATIONAL WIRING REGULATIONS.

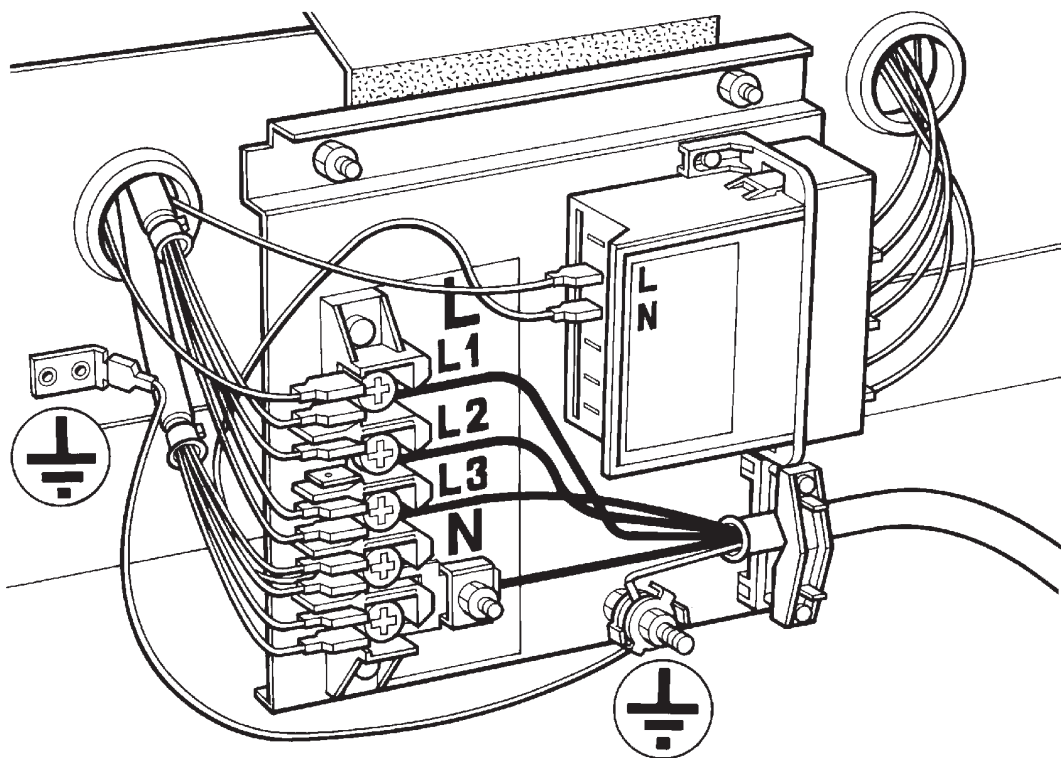

Fig. 2b

DESN 512313

CONNECTING TO GAS

To allow ease of servicing and cooker mobility, an approved flexible 4ft hose should be fitted. Supply piping should not be less than R 1/2 (1/2" BSP). Connection is made to the R 1/2 (1/2" BSP) female threaded entry in the inlet block located just below the hotplate level on the rear right hand side of the cooker.

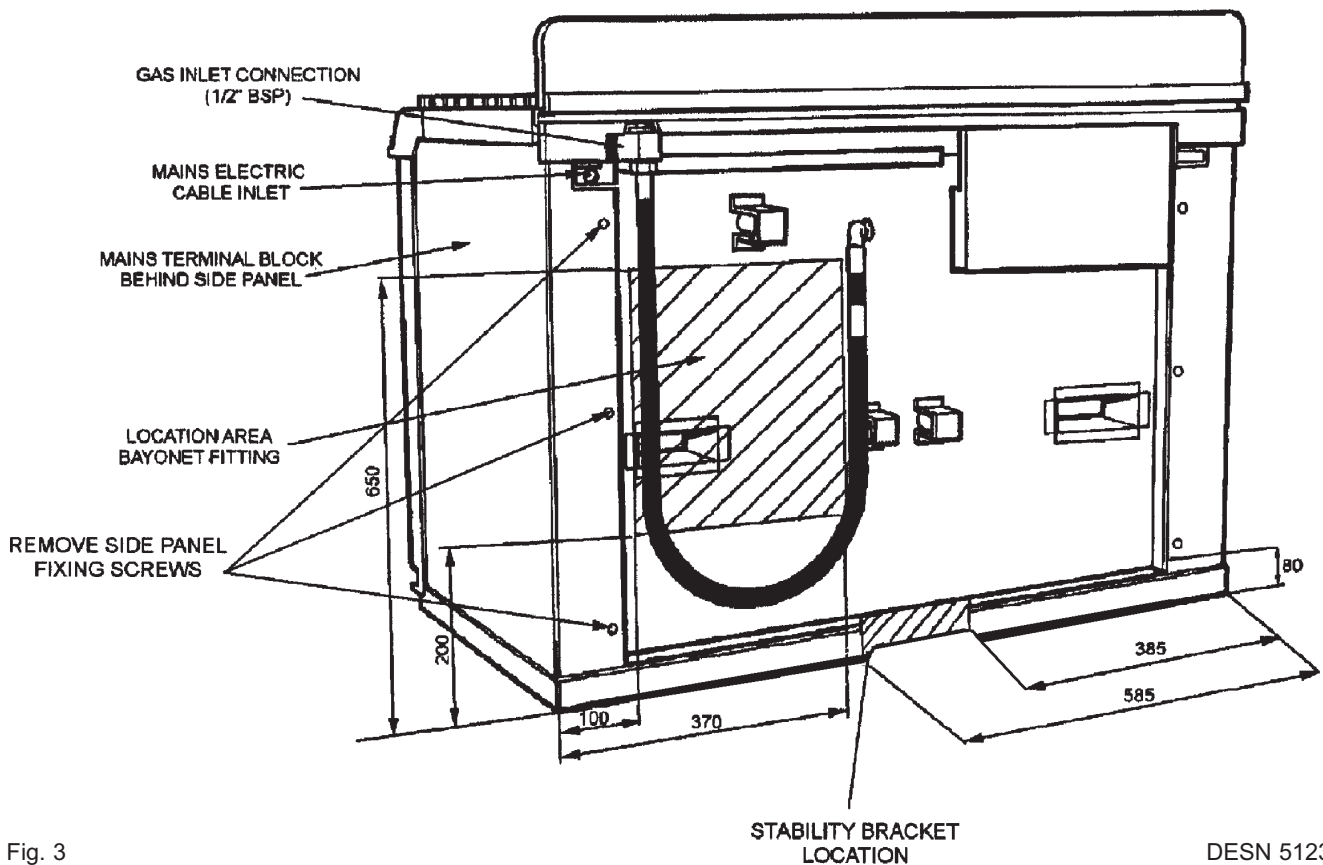

Fig. 3

DESN 512389

The gas bayonet connector must be fitted to the wall in the shaded area dimensioned in Fig. 4. Take into account that it must be possible to pull the cooker forward sufficiently for servicing. Ensure flexible hose is not trapped between cooker back panel and rear wall. Ensure hose is routed within the shaded area and away from shielded oven vent. The flexible hose must be in accordance with the relevant standards.

IMPORTANT: THE GAS SUPPLY CONNECTION AT THE WALL MUST NOT PROJECT OUT FROM THE WALL BY MORE THAN 45MM, SO THAT IT DOES NOT FOUL WITH THE BACK OF THE COOKER.

Check for gas soundness after connecting the appliance.

COOKER STABILITY

A stability bracket shall be secured firmly to the fabric of the building, when the appliance is connected to the gas supply by a flexible hose. For positioning of bracket (See Fig. 3). A safety chain must also be anchored firmly to the wall and cooker to prevent the flexible hose from straining, when the cooker is withdrawn for servicing. When fitting a stability bracket and chain refer to dimensions in Fig. 3 and Fig. 3A.

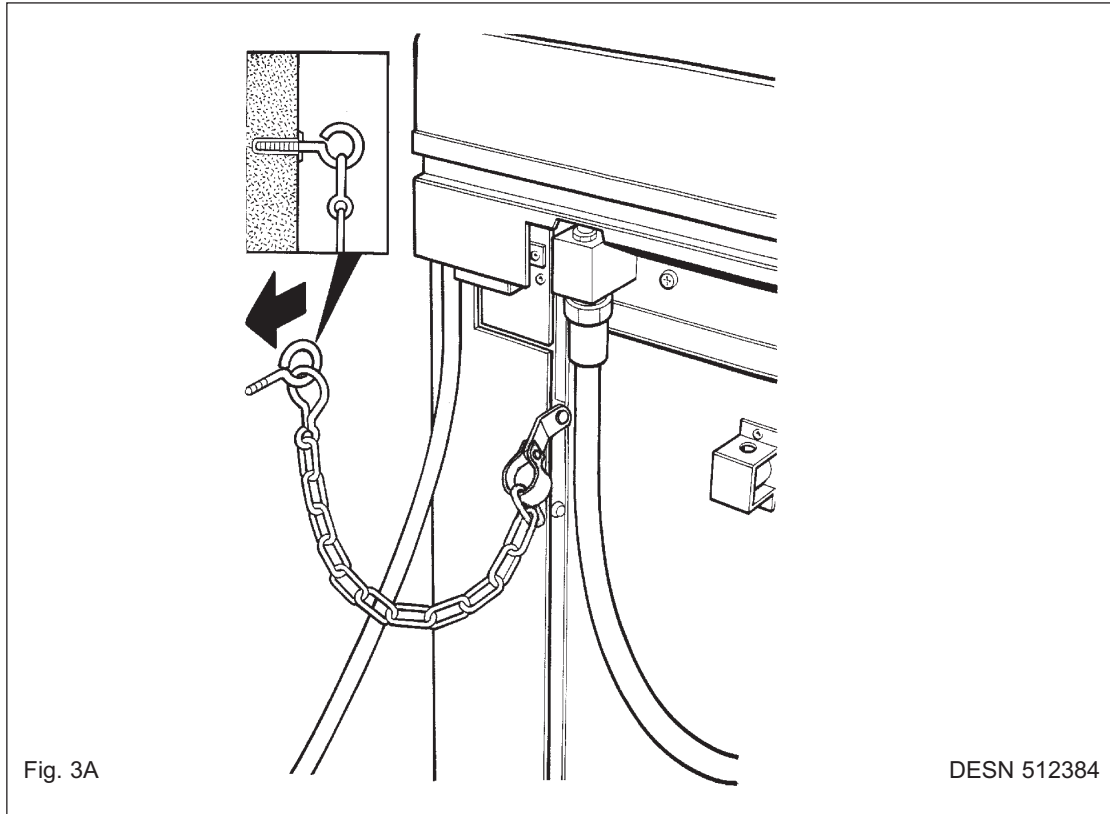

POSITION OF GAS BAYONET ON WALL (locate in shaded areas)

IMPORTANT: THE GAS SUPPLY CONNECTION AT THE WALL MUST NOT PROJECT OUT FROM THE WALL BY MORE THAN 45MM, SO THAT IT DOES NOT FOUL WITH THE BACK OF THE COOKER.

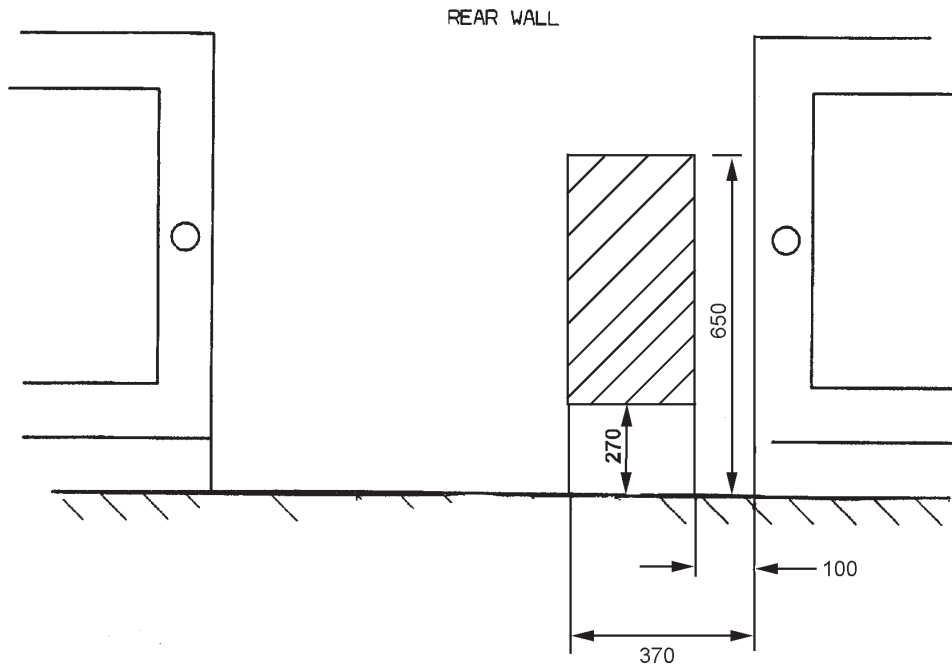

Fig. 4

DESN 512390 A

PRESSURE TESTING

The pressure test point is situated at the rear right hand side of the hotplate.

Place the wok burner head, burner cap and ring into position on the hotplate. Light the burner by pushing in the appropriate control knob, and turning it anti-clockwise IGNITION position, until gas ignites, then continue to turn to the FULL ON position.

For Natural Gas appliance, the pressure should be 20mbar (8 inches water gauge).

Turn off the tap, disconnect the pressure gauge and refit test point blanking screw.

LEVELLING AND MOBILITY WHEELS

INSTALLATION/LEVELLING

The cooker is fitted with mobility rollers, two at the rear and two at the front.

The DC6 is designed to stand on a flat and level surface, however, any unevenness may be overcome by adjusting the four levelling feet, one at each corner of the base plate. The adjusting screws are accessed by removing left and right hand hotplate castings (See section 'To Remove Hotplate Castings - Servicing Section Page 50'). To raise the cooker turn screw clockwise, to lower turn screw anti-clockwise.

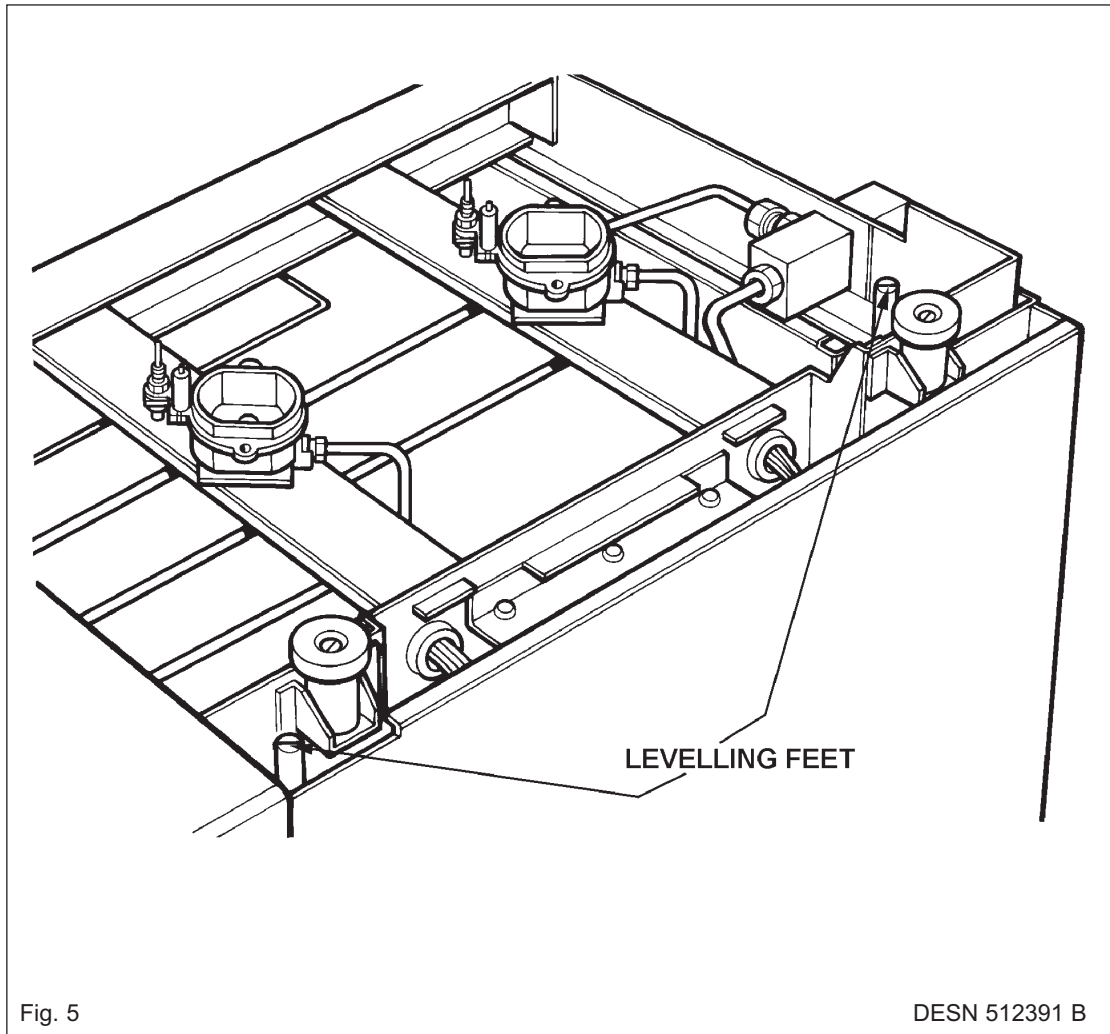

There are rollers on the base of the cooker to allow for positioning.

When the cooker is in the correct position the four levelling feet can be adjusted to level the cooker. **THE FEET MUST BE LOWERED ENOUGH TO PREVENT THE COOKER ROLLING OUT OF POSITION.** (See Fig. 5)

FITTING OF HOTPLATE CASTING AND PAN SUPPORTS

HOTPLATE CASTINGS

1. Attach earth cable from centre casting to cooker chassis and locate over burner bodies. Repeat for LH and RH castings and that the gaskets are fitted where the outer castings overlap centre castings. Ensure that earth cables are attached. (See Fig. 6A)

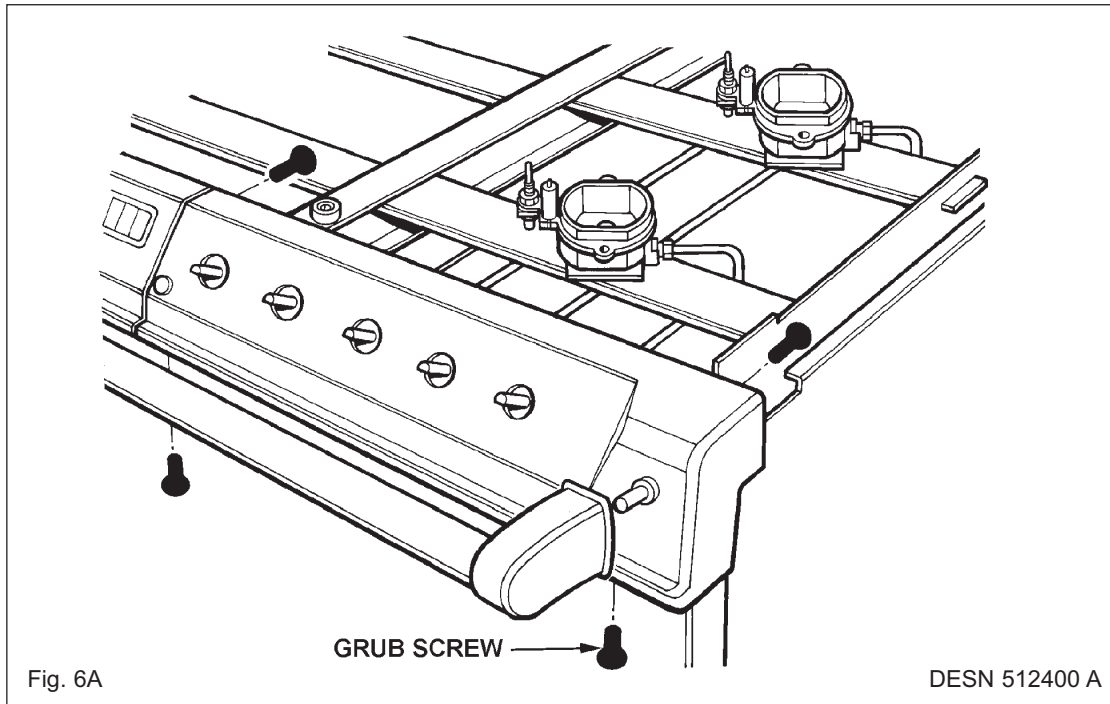

2. Secure castings using 8 profiled fixing nuts. **DO NOT OVERTIGHTEN.** (See Fig. 6B).

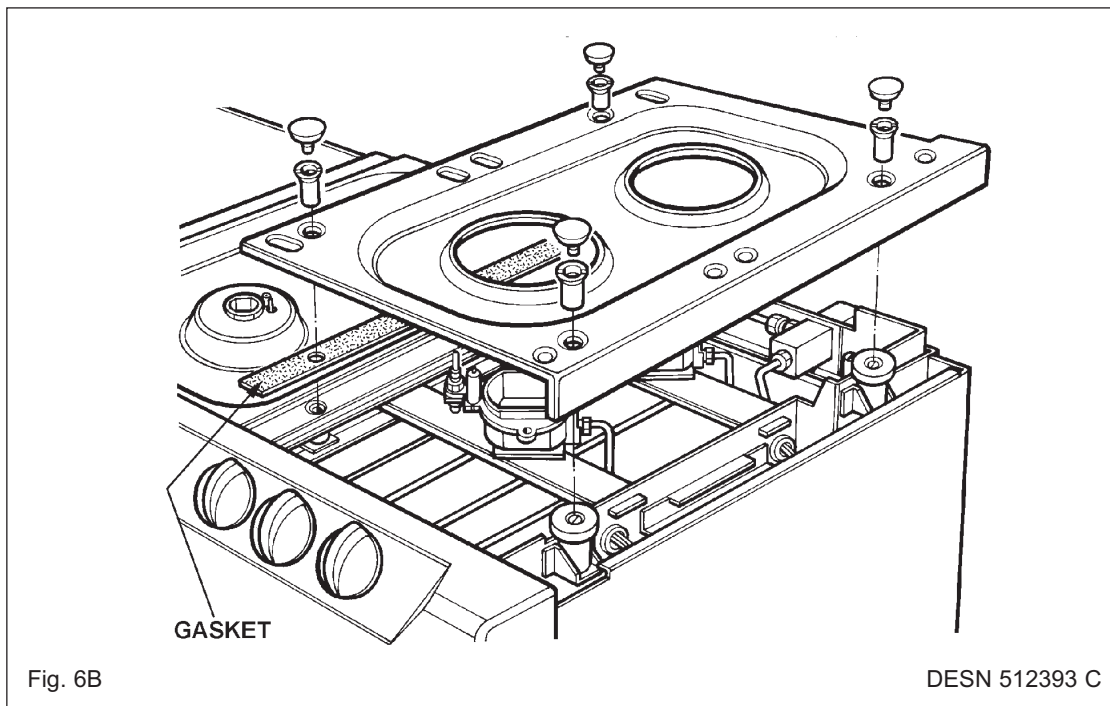

- Fit and secure six burner rings using M4 screws on rear left hand, front centre, front right hand and rear right hand burners. Use No.6 3/8 screw on front left hand and centre rear burners. (See Fig. 6C).
NOTE: The fitting of LH and centre burners are the same as shown in Fig. 6B.

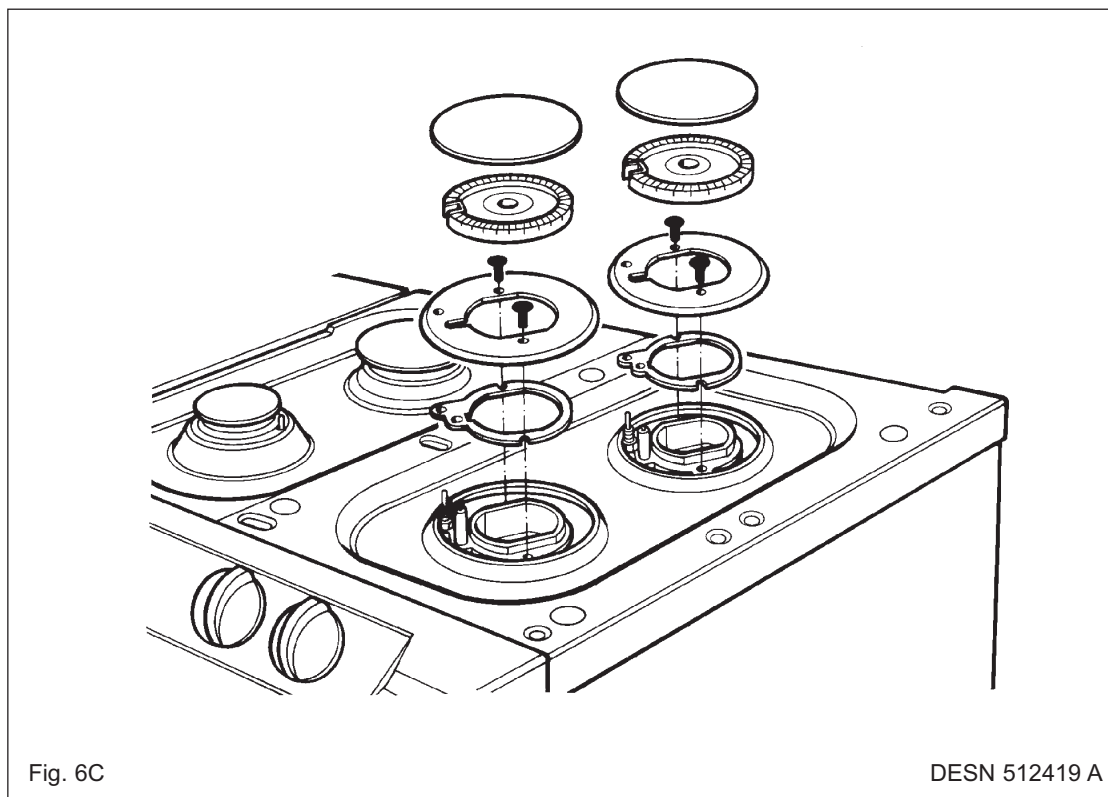

- Position burner caps onto burner bodies. (See Figs. 7A, 7B, & 7C).

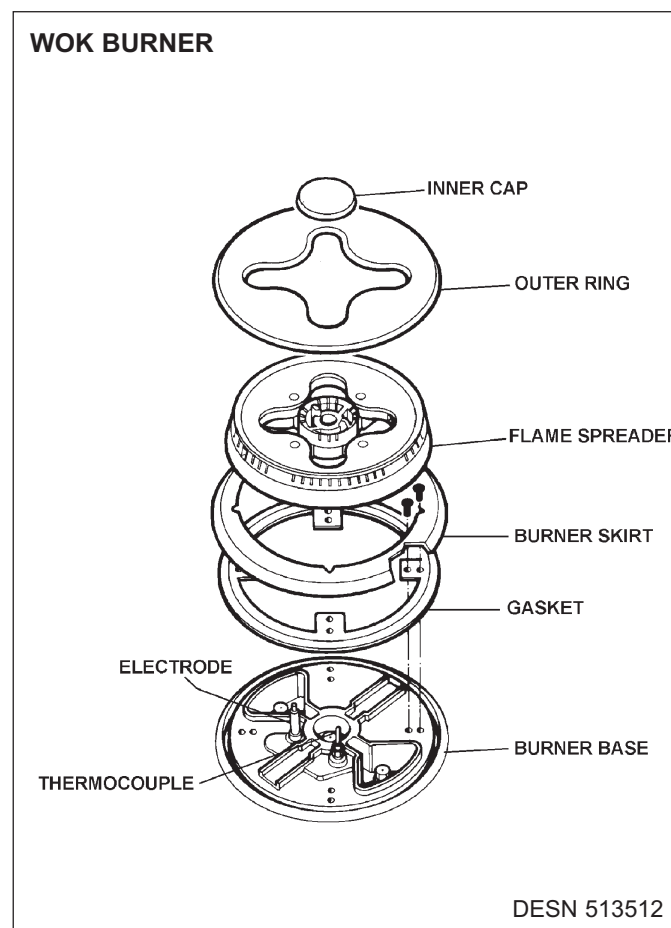
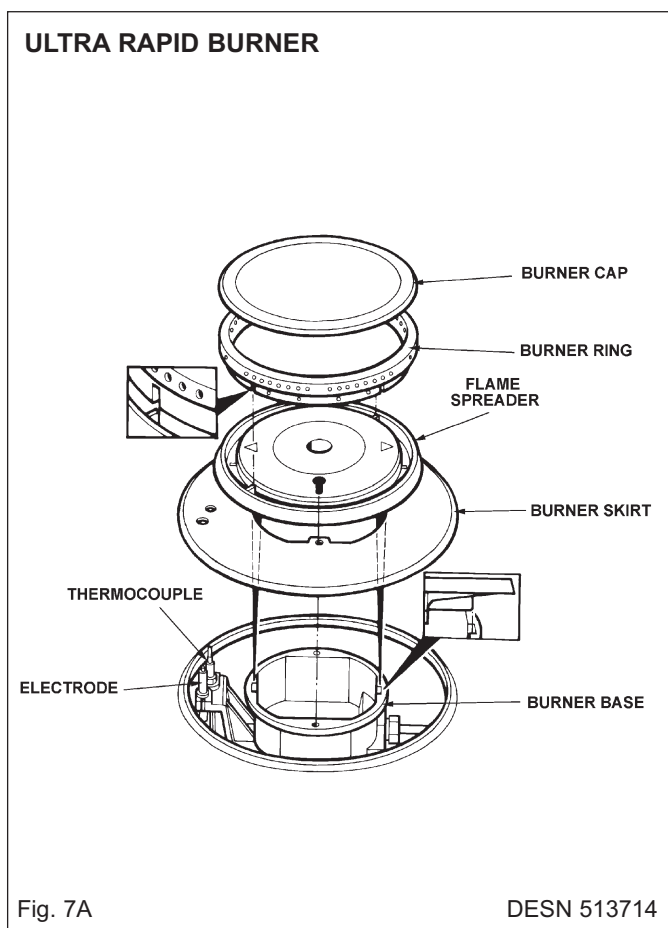

**ASSEMBLY OF RAPID AND SEMI-RAPID
BURNERS**

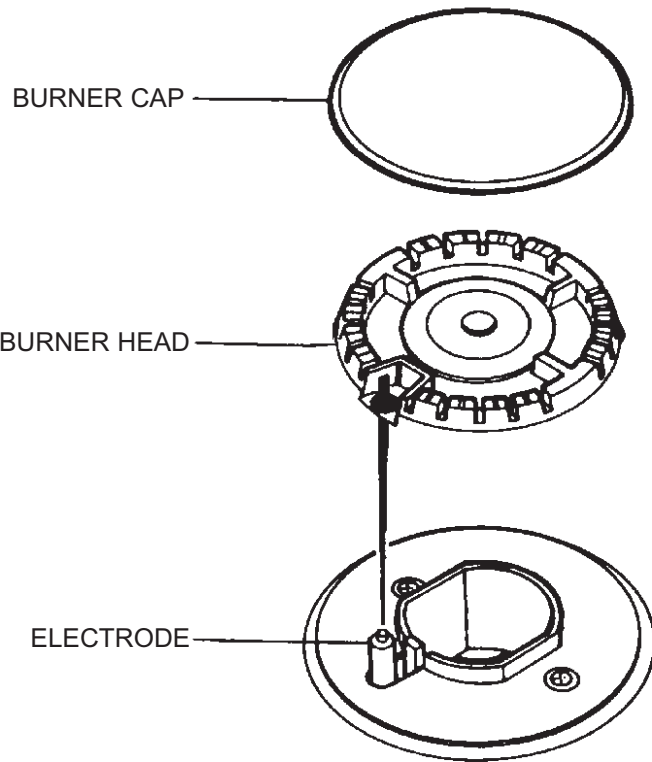

Fig. 7B

DESN 511618

**FITTING BURNER CAP - RAPID AND SEMI-RAPID
BURNERS**

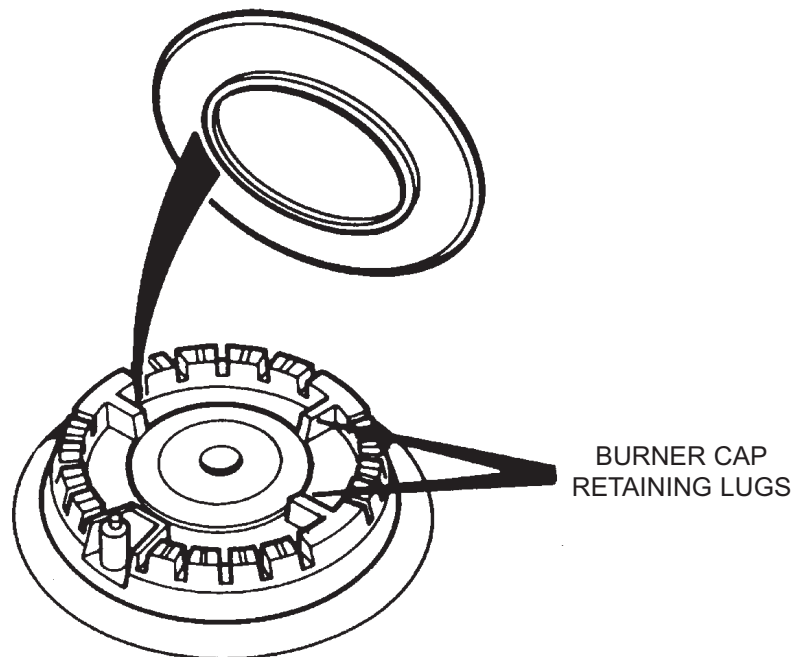

Fig. 7C

DESN 511617

5. Fit the pan supports in the following order The pan supports are marked on the underside to correspond to the markings below. The pan supports must locate in the recesses in the hotplate casting. (See Fig. 8A & 8B)

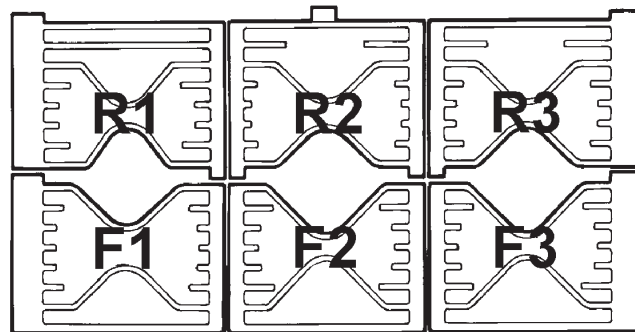

Fig. 8A

DESN 513712 A

Important

It is very important for the performance and reliability of the hob that the pan supports are fitted in accordance with the AGA SIX-FOUR SERIES - DC6 OWNERS MANUAL.

To help identify the correct location of the pan supports, the centre rear pan support has been uniquely designed with a tag, as shown. This pan support must be fitted in the rear centre position with the tag pointing towards the back of the appliance.

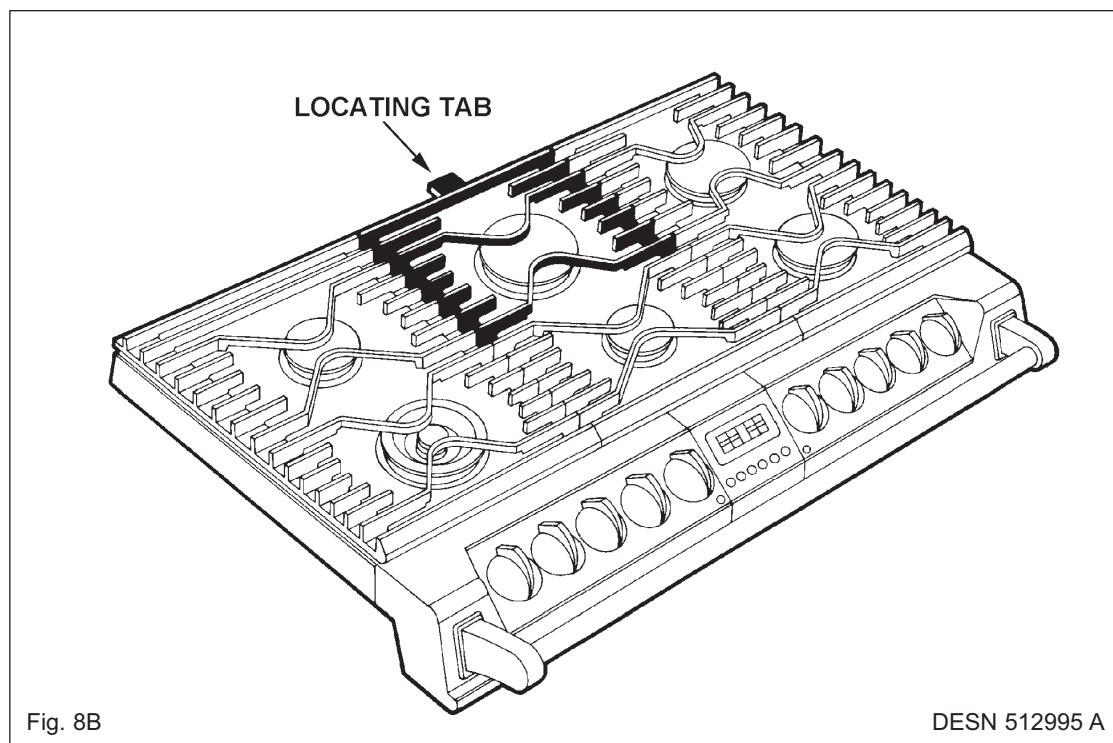

Fig. 8B

DESN 512995 A

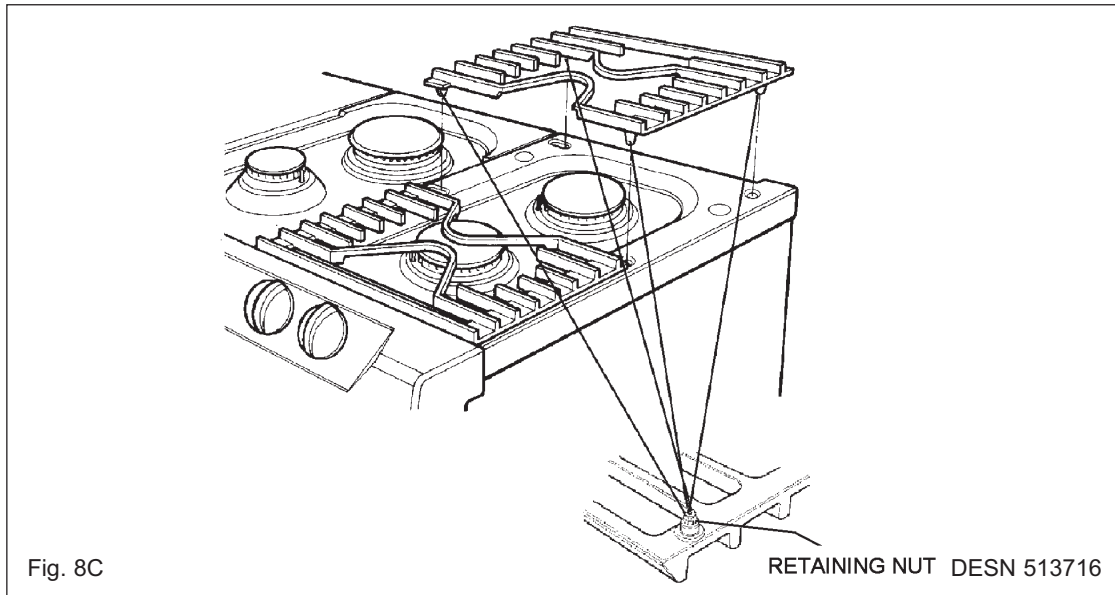

Fig. 8C

RETAINING NUT DESN 513716

TO ADJUST PAN SUPPORT LEVEL

1. Loosen retaining nut using 8mm spanner (See Fig. 8C).
2. To prevent rocking adjust the pan support foot using 2.5mm allen key.
3. Check pan support is level with opposing pan supports.
4. Retighten retaining nut.

HANDRAIL FITTING

1. Position handrail assembly onto locating studs at each end of fascia. Ensure the grub screw at each end of the hand rail is facing downwards.
2. Push handrail assembly fully against fascia and lock in place by tightening 2 grub screws (2 1/2 mm). (See Fig. 6A).

SPLASHBACK

1. Locate tabs on rear of splashback assembly, into the brackets on the upper rear of the cooker. (See Fig. 9).
Push fully into place.

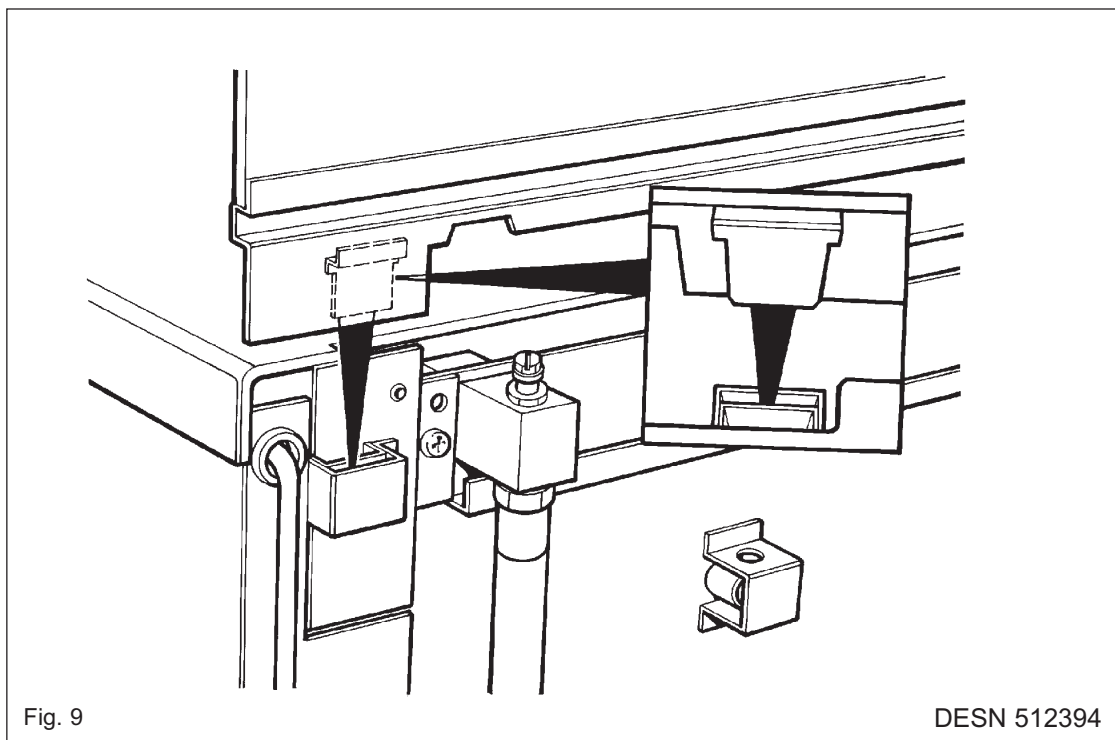

Fig. 9

DESN 512394

Users

Guide

GENERAL INFORMATION

As responsible manufacturers we take care to make sure that our products are designed and constructed to meet the required safety standards when properly installed and used.

IMPORTANT NOTICE: PLEASE READ THE ACCOMPANYING WARRANTY.

Any alteration that is not approved by AGA could invalidate the approval of the appliance, operation of the warranty and could affect your statutory rights.

In the interests of safety and effective use, please read the following before using your new AGA appliance.

The use of gas on a cooking appliance results in the production of heat and moisture in the room in which it is installed. Ensure that the kitchen is well ventilated, keep the natural ventilation holes open or install a mechanical ventilation device (mechanical extractor hood).

Prolonged intensive use of the appliance may call for additional and/or more effective ventilation, for example, opening of a window, or, increasing the level of mechanical ventilation where present.

Installation must be to local and National IEE Wiring Regulations and carried out by a qualified Gas Safe Registered Engineer, from an authorised distributor.

A little smoke and some odour may be emitted when first switched on. This is normal and harmless (from oven lagging and starch binder on the element insulation) and will cease after a short period of use.

Your appliance has a gas hob, three electric ovens; the lower right hand oven is a slow cooking oven, the upper right hand oven is a conventional oven.

The lower left hand oven is an electric fan oven. The fan behind the rear panel ensures an even distribution of heat within the oven during cooking, ie. the temperature at the lowest shelf position is the same as the temperature at the highest shelf position.

The electric grill is situated in the roof of the top left hand compartment.

Refer to the diagram (See Fig. 10) to familiarise yourself with the cooker and refer to the relevant section for the simmering oven, fan oven, conventional oven, grill and gas hotplate etc.

Your cooker is supplied with the following accessories:

- 5 oven shelves
- 1 large roasting tin
- 1 grill shelf
- 1 grill pan
- 1 grill grid
- 1 baking tray
- 1 griddle plate

The following loose parts are also packed with:

- 6 pan supports (cast)
- 3 spillage wells (cast)
- 6 burner caps
- 6 burner heads
- 1 burner ring
- 1 handrail assembly
- 1 splashback assembly
- 1 fitting kit
- 6 burner skirts
- 2 spacer rings
- 6 gaskets

HEALTH & SAFETY

APPLIANCE

YOUNG CHILDREN SHOULD BE KEPT AWAY FROM THE APPLIANCE AS SOME SURFACES CAN BECOME HOT TO TOUCH.

- During use the appliance can become hot. Care should be taken to avoid touching heating elements inside the oven.

Deep Fat Frying

- Use a deep pan, large enough to completely cover the appropriate heating area.
- Never fill the pan more than one-third full of fat or oil.
- Never leave fat or oil unattended during the heating or cooking period.
- Never use a lid on the pan.

- **IMPORTANT:** Oil is a fire risk, do not leave pans containing oil unattended.
- In the event of fire cover with a lid and turn **OFF** the appliance.

Do not attempt to extinguish the fire using water.

Smother the flames on the hob, rather than attempting to remove the pan to the outside.

Burns and injuries are caused almost invariably by picking up the burning pan to carry outside.

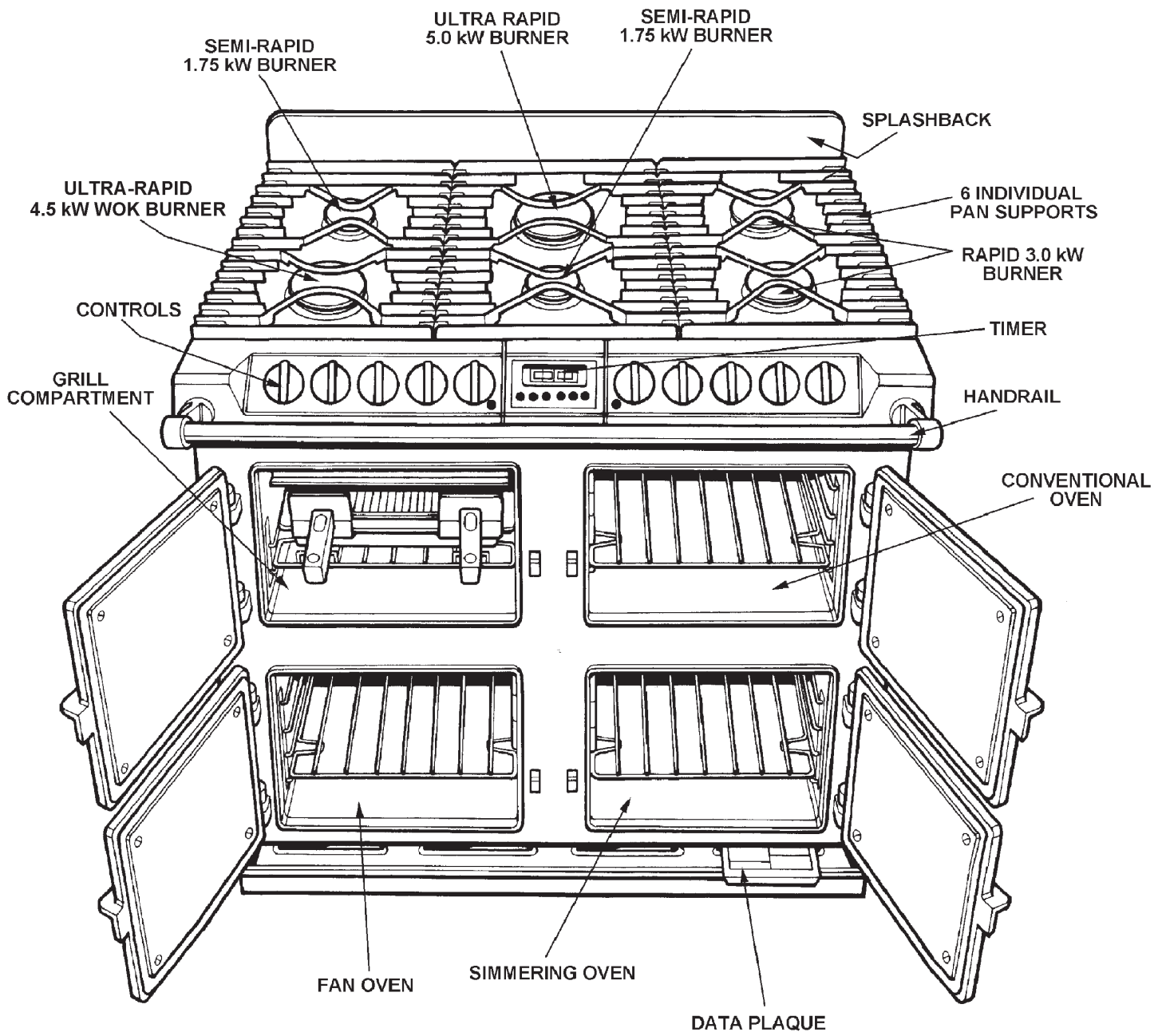

Fig. 10

DESN 512395 B

CONTROL PANEL

- The **GAS HOTPLATE CONTROL KNOBS** can only be rotated anti-clockwise from the **OFF** position.

✨ Symbol - Ignition Setting
 Large Flame Symbol - High Setting
 Small Flame Symbol - Low Setting

(See 'HOTPLATE' section).

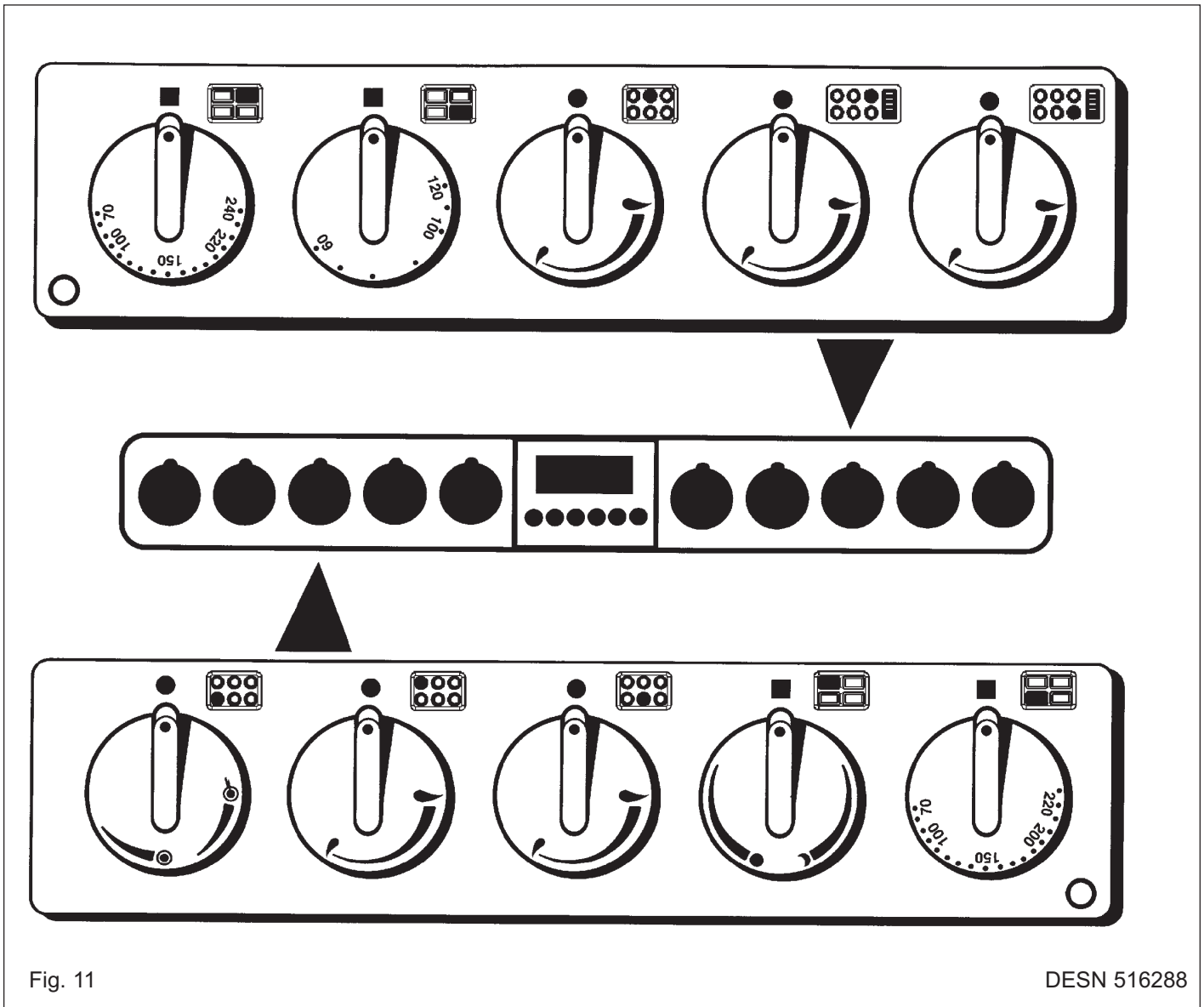

Fig. 11

DESN 516288

- The **GRILL ELEMENT CONTROL KNOB** can be rotated in either direction.

<i>Clockwise</i>	Full on, with both elements on
<i>Anti-clockwise</i>	Economy grill, centre element only
- The **OVEN CONTROL KNOBS** can only be rotated *clockwise* from the OFF position.
- The **OVEN NEONS** illuminate when ovens are switched on. When the required temperature is reached the neon will extinguish.

GAS HOTPLATE

- The hotplate has six gas burners:
 - front left** - ultra rapid (wok) burner - rated at 4.5 kW
 - rear left and front centre** - semi-rapid burners - each rated at 1.75 kW
 - rear right and front right** - rapid burner - each rated at 3.0 kW
 - centre rear** - ultra rapid burner - rated at 5.0 kW
- The semi rapid burners are especially suited for use with small pans and gentle simmering or poaching.
- All burners have a set simmer position and are easily adjustable.

TO USE THE HOTPLATE

- To light a hotplate burner, push in and turn the control knob anti-clockwise to the large flame symbol (), and hold in for 3 seconds until the burner lights, then turn the knob to the required setting.
- If the burner flame should accidentally go out, turn off the burner control and do not attempt to re-light the burner for at least one minute.
- The control may be set towards a lower position, simply by turning the control knob towards the small flame symbol.
- **IMPORTANT:** The cast iron pan supports on the appliance are much heavier than those on most gas hotplate cookers, therefore care must be taken when removing or refitting them to the hob. It is important that they are lifted from the appliance and not dragged across adjacent enamelled components which would result in damaging the enamel.

SOME SAFETY POINTS

- Simmering aids such as asbestos or mesh mats are not recommended. They can impede burner performance, damage the pan supports and waste fuel.
- Commercially available foil spillage aids are unnecessary on this cooker and could effect the combustion.
- Some 'Wok' cooking pans are unstable. Check with the 'Wok' manufacturer before purchasing.
- Do not use unstable and misshapen pans (e.g. with convex bases) that tilt easily.
- Pans and kettles with concave bases should not be used.
- The minimum pan diameter recommended is 120mm. Maximum recommended is 280mm.
- Never use pans which overhang the front of the fascia.
- Place all pans centrally over the burners. The flames must be on the base of the pan. Do not allow the flames to go up the sides of the pan. (See Fig. 12).
- Always position pan handles away from the front of the cooker - out of reach of small children.
- **NEVER** leave a chip pan unattended.

NOTE

Aluminium pans may cause a metallic marking on the pan supports. This will not affect the durability of the enamel. The appliance warranty does not cover mis-use of the pan supports.

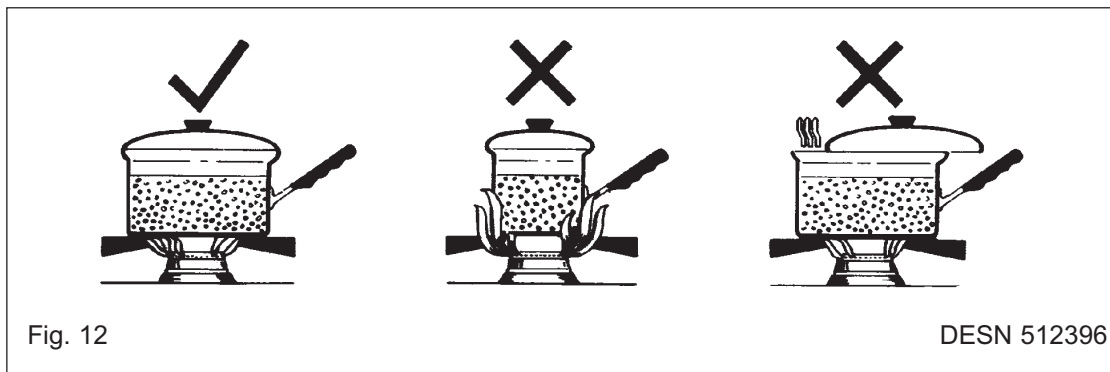

TO FIT PAN SUPPORTS

Fit the pan supports in the following order. The pan supports are marked on the underside to correspond to the markings below. The pan supports must locate in the recesses in the hotplate casting.

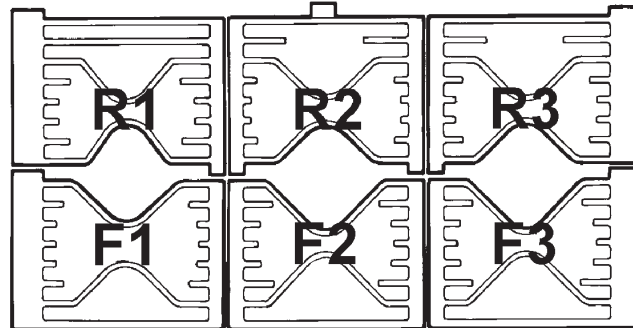

Fig. 13A

DESN 513712 A

Important

It is very important for the performance and reliability of the hob that the pan supports are fitted in accordance with the AGA SIX-FOUR SERIES - DC6 OWNERS MANUAL.

To help identify the correct location of the pan supports, the centre rear pan support has been uniquely designed with tag, as shown. This pan support must be fitted in the rear centre position with the tag pointing towards the back of the appliance.

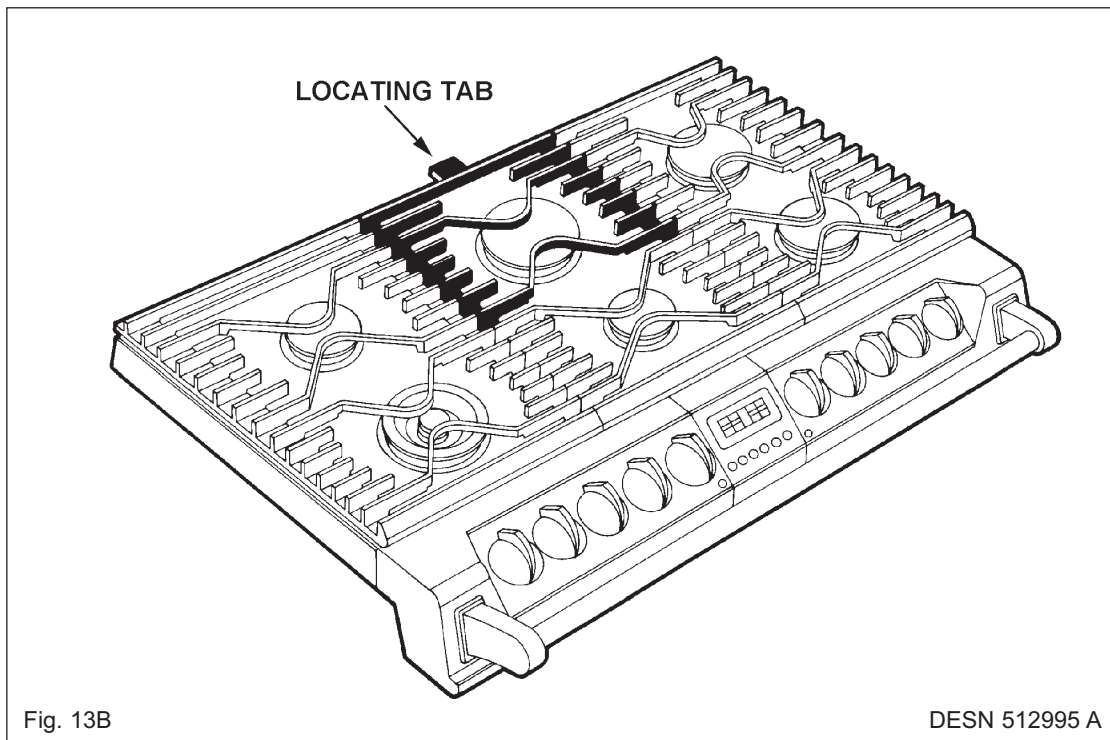

Fig. 13B

DESN 512995 A



SETTING UP THE COOKER FOR USE

Before you can use the lower left hand oven of the appliance it will be necessary to set the 'time of day' clock.

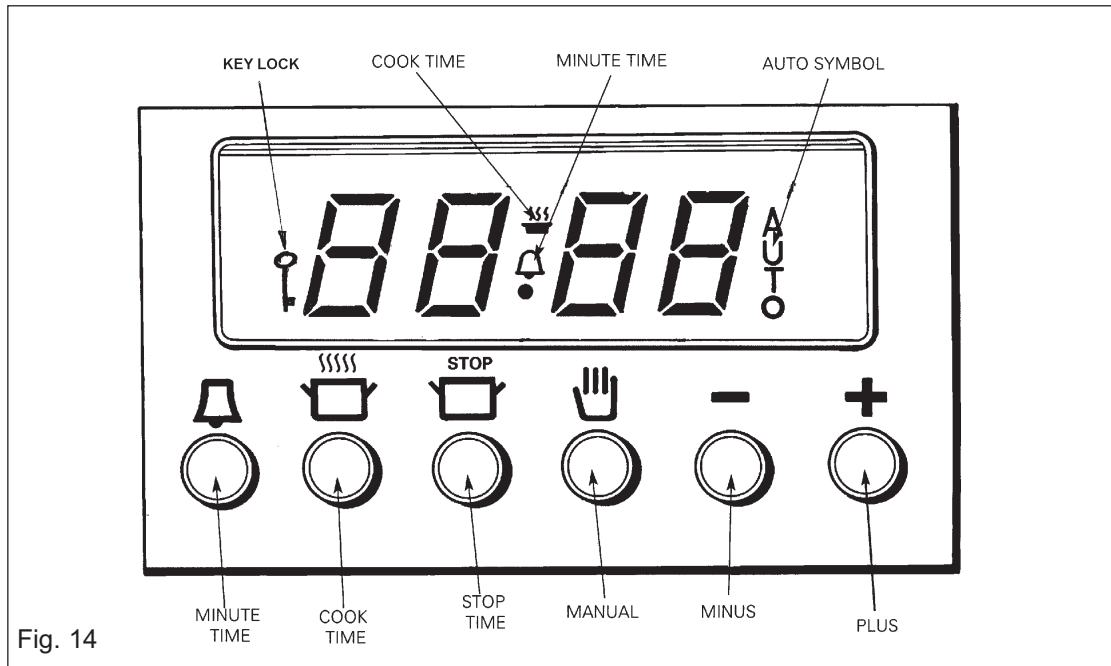
This is a 24 hour clock, and when the power supply is initially switched on, or after an interruption in supply, the clock will show **AUTO** and **0.00** alternately.



SETTING THE TIME OF DAY

1. Press and hold the **MINUTE TIMER**  and **COOK TIME**  buttons at the same time, (the word **AUTO** flashes and the **0.00** is displayed steadily) press the plus **+** or minus **-** buttons until the required time of day is displayed. The time will increase/decrease from 12.00 hours in minute intervals, slowly and then gaining speed. .

The cooker is now ready for manual use.

GRIDDLE PLATE

- The griddle plate is designed for use **ONLY** on your AGA DC6 Natural Gas cooker.
- **It MUST only be used on the right hand rapid burners.**
- It should be positioned on the pan supports as below to ensure correct and safe operation.

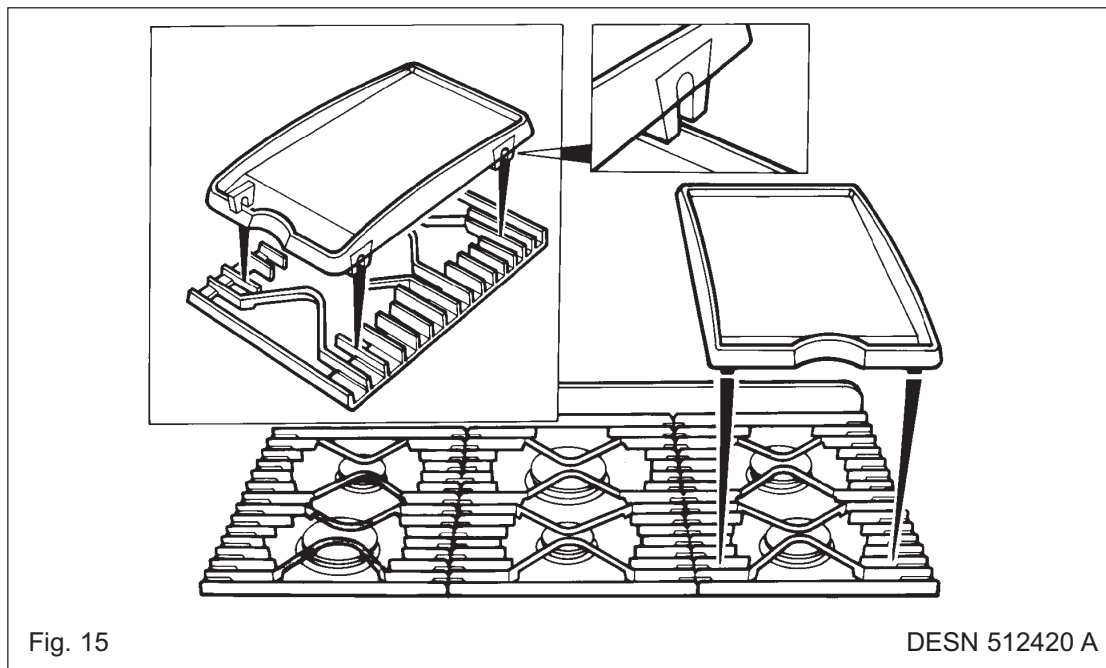

USING THE GRIDDLE

BEFORE POSITIONING THE GRIDDLE PLATE ON THE PAN SUPPORTS, THE BURNERS SHOULD BE LIT AND TURNED DOWN TO THE SIMMER POSITION. (SMALL FLAME SYMBOL, PAGE 21).

- Pre-heat the griddle plate for 5 - 10 minutes before cooking.
- It should not be necessary to use any extra fat when griddle cooking. This will only effect the efficiency of the non-stick cooking and will make cleaning more difficult.
- Always use utensils which will not scratch the special non-stick surface i.e. nylon, wood and non-stick.
- Do not use sharp utensils such as forks or knives.
- Do not use or rest saucepans on the griddle plate.
- The griddle plate can be removed and taken to the sink for washing.
- It should only be necessary to use hot soapy water to clean the griddle as abrasive cleaners will damage the surface.
In the event of heavy soiling only nylon pan scourers should be used with care.

SIMMERING OVEN

THE SIMMERING OVEN

This is used for long, slow cooking over 6-8 hours, keeping food warm and warming plates for short periods.

EXTRA CARE MUST BE TAKEN WHEN WARMING BONE CHINA - USE THE LOWEST SETTING.

The slow cooking setting is the area marked between 110°C - 120°C on the oven control knob.

USING THE SIMMERING OVEN SETTING

Points to bear in mind when preparing food.

- For best results use the AGA Stainless Steel Cookware, AGA recommend AG30012 - Saute Casserole Dish and Lid.
- Do not place dish directly on to the oven base. Always place onto shelf supplied. See Fig. 18A.
- Joints of meat and poultry should be cooked at 180°C for 30 minutes before transferring to the slow cooking oven.
- The meat/poultry should be entirely wrapped in 2 layers of foil to ensure a tight seal is achieved, this will retain the natural juices and flavours that are lost when food is cooked at a higher temperature. The foil join must be positioned at the top of the joint to prevent leakage.
- Always stand covered joints on a rack over a meat tin, to allow good air circulation.
- Meat over 2.7kg (6lbs) and poultry over (4lbs 8ozs) are unsuitable for the slow cooking method.
- This method is unsuitable for stuffed meat and poultry.
- Make sure that pork and poultry reach an internal temperature of at least 90°C.
- Always bring, soups, casseroles and liquids to the boil before putting in the oven.
- When cooking casseroles or braising meat cover the food first with foil and then the lid to create a good seal and preventing the loss of moisture.
- All dishes cooked by the slow cooking method should be cooked for a minimum of 6 hours. They will 'hold' at this setting for a further 1-2 hours but marked deterioration in appearance will be noticed in some cases.
- Push dishes well back in the oven to ensure that they are positioned over the element beneath the base plate.
- Always thaw frozen food completely before cooking.
- Root vegetables will cook better if cut into small pieces.
- Adjust seasonings and thickenings at the end of the cooking time.
- Egg and fish dishes need only 1-5 hours cooking and should be included in day cooking sessions, where they can be observed from time to time.
- Dried red kidney beans must be boiled for a minimum of ten minutes, after soaking, and before inclusion in any dish.

STORAGE AND RE-HEATING OF FOOD

- If food is to be frozen or not served immediately, cool it in a clean container as quickly as possible.
- Thaw frozen food completely in the refrigerator before re-heating.
- Re-heat food thoroughly and quickly either on the hotplate or in a hot oven 180°C, and then serve immediately.
- **Only re-heat food once.**

IDEAS FOR THE SIMMERING OVEN

Many favourite recipes can be adapted for this type of cooking. Check that chosen ovenware will fit into the oven.

Meal 1 6 - 8 hours cooking

Ragout of Beef in Ale

Baked Potatoes

Recipes

30ml (2tbsps) oil
675g (1½ lbs) chuck steak, cubed
1 clove of garlic, crushed
2 carrots, sliced
100g (4oz) mushrooms, quartered
2 medium onions, sliced
40g (1½ ozs) plain flour
5ml (1 tsp) coarse-grained mustard
10ml (1dsp) demerara sugar
30ml (2tbsps) tomato purée
450ml (¾ pt) brown ale
salt and freshly ground pepper

Ragout of Beef in Ale

1. Sauté the meat in hot oil in a flame proof casserole dish until brown.
2. Sauté the garlic, onions, carrots and mushrooms until brown.
3. Stir in flour and mix well.
4. Add mustard, sugar and tomato purée.
5. Stir in the ale and seasoning. Return meat.
6. Bring to the boil and cover. Transfer to oven.

Baked Potatoes

4 medium sized potatoes

1. Wash and prick well all over.
2. Wrap in one layer of foil.
3. Place directly on the shelf.

Meal 2 6 - 8 hours cooking

Roast Fillet of Lamb

Dauphinoise Potatoes

Bread and Butter Pudding

Recipes

Roast fillet of Lamb

900g - 1.25 kg (2-2 1/2 lbs) lamb

1. Season and wrap the lamb in foil.
2. Stand meat on a rack (if possible) over a small shallow tin.

Dauphinoise Potatoes

450g (1lb) potatoes, thinly sliced
1-2 cloves of garlic, crushed
125ml (1/4 pt) double cream
salt and freshly ground black pepper

1. Grease a shallow oval or rectangular dish.
2. Arrange layers of potatoes, seasoning and garlic in the dish, ending with potatoes.
3. Pour over the cream and cover well with foil.

Bread and Butter Pudding

6-8 medium slices of wholemeal bread
Approx 50g (2ozs) butter, melted
Grated rind of one orange (optional)
25g (1oz) desiccated coconut
50 - 100g (2 - 4oz) luxury/tropical mixed fruit
50g (2oz) soft brown sugar
450ml (3/4 pt) milk
2 eggs

1. Grease a shallow oval or rectangular dish.
2. Cut the crusts off the bread and divide into rectangles/triangles.
3. Dip enough pieces of bread in the butter on one side to cover the base of the dish, butter side up.
4. Sprinkle with half of the fruit, coconut, sugar and orange rind.
5. Cover with a second layer of bread dipped in the butter and then the remaining rind, fruit, coconut and sugar.
6. Whisk the eggs and milk together and pour over the bread. Stand for 1/2 hour before baking. Leave uncovered in the oven.

Meal 3 6 - 8 hours cooking

Gammon and Apricot Pie

Braised Red Cabbage

St. Clements Pudding

Recipes

2 gammon rashers approx 15mm (1/2") thick
100g (4oz) no-soak dried apricots
25g (1oz) sultanas
3 large potatoes, thinly sliced
300ml (1/2 pt) chicken stock
50g (2oz) butter, melted

Gammon and Apricot Pie

1. Remove the rind from the gammon. Nick the edges and lay them in a shallow dish.
2. Sprinkle with apricots, sultanas and pepper.
3. Overlap the sliced potatoes on top of the gammon. Pour over stock.
4. Brush with melted butter place in the oven.

Braised Red Cabbage

350g (3/4 lb) red cabbage
25g (1oz) butter
1 medium onion, sliced
1 medium cooking apple, sliced
30ml (2 tbsps) cider vinegar
45ml (3 tbsps) honey
salt and pepper

1. Slice the red cabbage finely
2. Melt the butter in a large saucepan and sauté the onion and apple until starting to soften.
3. Add the cabbage and cook for a further 2 minutes
4. Mix in the vinegar, honey and seasoning.
5. Transfer to an ovenproof dish, and cover tightly with foil. Place in the oven.

St Clements Pudding

2 rounds of thick sliced wholemeal bread
a little milk
50g (2oz) butter or margarine
50g (2oz) soft brown sugar
grated rind and juice of 1 lemon
grated rind and juice of 1 orange
3 eggs, separated
caster sugar for sprinkling

1. Grease a shallow oven-proof dish and line the base with fingers of bread.
2. Pour over sufficient milk to be absorbed by the bread.
3. Cream the fat and sugar.
4. Add the yolks, lemon and orange rind and juice. Beat.
5. Whisk the egg whites stiffly and fold most of them into the creamed mixture.
6. Spread this mixture over the bread.
7. Finish with a layer of the remaining egg white, thickly dredged with sugar. Leave uncovered. Place in the oven.

Meal 4

Chilli Con Carne

Frangipane and Apple Pudding

Recipes

Chilli Con Carne

450g (1lb) minced beef
1 x 400g (14oz) tin tomatoes
1 x 400g (14oz) tin kidney beans
1 packet Chilli con carne spice mix
100ml (4 fl oz) water

1. Brown the minced beef in a flame proof casserole dish.
2. Stir in the spice mix.
3. Add beans drained, tomatoes and water.
4. Mix well together. Bring to boil, cover well and place in oven.

Frangipane and Apple Pudding

450g (1lb) cooking apples, grated
50g (2oz) vanilla fudge, chopped
50g (2oz) softened butter
50g (2oz) soft brown sugar
50g (2oz) ground almonds
12g (1/2 oz) plain flour
1 egg
almond essence

1. Grease a shallow oven dish.
2. Mix the apples and fudge together and place into the dish.
3. Cream the rest of the ingredients and add a few drops of almond essence.
4. Carefully spread over the apple. Leave uncovered and place in oven.

THE GRILL

- **THE GRILL COMPARTMENT DOOR MUST BE KEPT OPEN WHEN THE GRILL IS ON.**
- **CAUTION: Accessible parts may be hot when the grill is in use. Young children should be kept away.**
- The very high speed instant grill is divided into two areas to save energy and to suit individual grilling requirements.
- Turn the grill control clockwise and the whole of the grilling area can be used for large amounts of food. Turn the control anti-clockwise and the middle area only can be used for small amounts e.g. 2 slices of bread, one or two chops etc.
- Most food is cooked at a high setting but for thicker pieces of meat/poultry and for food such as well done steak the heat can be reduced by turning the control down to a lower setting.
- For best results pre-heat at a high setting for approximately 2 minutes.
- The grill pan fits on the shelf supplied. The shelf is designed to lock in place, but is removable for cleaning. See Fig. 18B .
- Food should be cooked on the grid or in the base of the grill pan. Some dishes can be placed straight onto the shelf or floor of the compartment. This is useful when browning the top of food such as cauliflower cheese.
- The oven side panels are self cleaning.
- The grill pan can be stored in the base of the grill compartment, when the grill is off.

The following information is for guidance only as shape, thickness, size of food and personal taste can vary.

FOOD	SUGGESTED HEAT SETTING
Toast	HIGH
Pikelet/Crumpet/Muffins	HIGH
Bacon	HIGH
Sausage	HIGH TO MED.
Beefburger	MED. as per packet instructions
Steak med./rare	HIGH TO MED.
Chops	HIGH TO MED.
Fish - whole	HIGH TO MED.
- steaks	HIGH TO MED.
- fillets	HIGH
Chicken portions	HIGH TO MED.
Toppings i.e. meringue, potato, cheese etc.	HIGH

THE OVENS

General

- The ovens and grill compartment are fitted with side and back self cleaning panels. The roof of the oven is also self-cleaning enamel.
- The shelves are designed to be non-tilt.
- To remove a shelf, lift clear of the side notches and slide forward. To replace a shelf, insert into the oven with the short prongs at the rear, facing upwards. Slide into position above the side notches then allow to drop down on the runner.
- Do not place the grid shelf or food on the bases of the ovens.
- Pre-heat the ovens at the appropriate settings until the neon light goes out.
- For effective heat distribution, leave a gap of no less than 12mm between the dishes and the sides of the oven.
- Do not use a tray or tin greater than the one supplied with the cooker.

Condensation

Condensation forms when heat and moisture are present, for example during cooking. Whenever possible try to make sure that the food which contains a lot of moisture is covered e.g. casseroles. If you do notice any condensation, wipe it up straight away.

OVEN COOKING GUIDE



Cooking Hints

- Shelf positions are counted from the bottom.
- Put dishes in the centre of the shelf.
- When using the fan oven, reduce conventional oven settings by 10°C - 20°C and in some cases, cooking time by up to 10 minutes for every hour.
- It is important to check that food is piping hot before serving.
- You can change the setting and cooking times to suit your tastes.

Deep Fat Frying

- Do not try to fry too much food at a time, especially frozen food. This only lowers the temperature of the oil or fat too much, resulting in greasy food.
- Always dry food thoroughly before frying and lower it slowly into the hot oil or fat. Frozen foods in particular, will cause frothing and spitting, if added too quickly.
- Never heat fat, or fry with a lid on the pan.
- Keep the outside of the pan, clean and free from streaks of oil or fat.
- The following chart gives a guide to cooking a number of every day items.

Conventional Oven

Conventional Oven • Conventional Oven • Conventional Oven • Conventional Oven

- The right hand upper oven is a conventional oven which means that the heating elements are in the top and under the base of the oven compartment.
- The cooking charts are a general guide but times and temperatures may vary according to individual recipes.
- The meat sections should be used as a general guide but may vary according to the size, shape of joint on or off the bone.
- Thaw frozen joints before cooking them.
- The times are for open roasting. If covered allow for extra time.
- The turkey/chicken is cooked when the juices run clear when pierced with a skewer. If the juices are still pink continue to cook, checking every 15 minutes.
- Shelves are numbered from the bottom upwards.

FOOD	SETTING °C	SHELF POSITION	APPROXIMATE COOKING TIME & COMMENTS
Fish			
Whole Fish e.g. trout, mackerel	190	2 or 3	25 - 30 mins depending on size
Steaks	190	2 or 3	20 - 25 mins depending on thickness
Oven-fried fish	210 - 220	3 or 4	25 mins depending on packet instructions
Salmon (2.7kg)	160 - 170	1 or 2	15 - 18 mins per 450g
Meat & Poultry			
Beef	180 - 190	1 or 2	30 mins per 450g + 30 mins over (medium rare)
Lamb	180 - 190	1 or 2	25 mins per 450g + 25 mins over
Pork	180 - 190	1 or 2	30 - 35 mins per 450g + 35 mins over
Chicken	190 - 200	1 or 2	20 - 25 mins per 450g + 20 mins over
Turkey	180 - 190	1	15 - 18 mins per 450g + 15 mins over
Duck & Goose	190 - 200	1	25 mins per lb + 25 mins over
Casserole	150 - 160	1 or 2	1 1/2 - 3 hours depending on recipe
Puddings			
Milk Puddings	160	1 or 2	2 hours
Baked Custard	150	1 or 2	35 mins
Baked Sponge Pudding	190	2 or 3	45 mins - 1 hour using raw fruit
Fruit Crumble	190 - 200	2 or 3	45 mins - 1 hour

FOOD	SETTING °C	SHELF POSITION	APPROXIMATE COOKING TIME
Meringue Toppings	140 - 150	1 or 2	45 mins
Meringues	100 - 110	2	3 - 4 hours - Turn meringues over as soon as they are set
Yeast Mixture			
Bread - loaves	220 - 230	1	30 - 45 mins
Bread - rolls	220 - 230	2 or 3	15 - 20 mins
Chelsea Buns etc	190	1 or 2	25 - 35 mins
Cakes, Pastries, Biscuits & Scones			
Small Cakes	190	3	20 - 25 mins
Victoria Sandwich	180	3	25 - 30 mins
Swiss Roll	190	2 or 3	7 - 10 mins
Fatless Sponge (180mm)	190	3	20 mins
Scones	220	3	10 - 15 mins
Maderia Cake	180	1 or 2	1 hour - Place on a piece of citron peel after 20 mins
Med. Rich Fruit Cake	150	1	2 - 2 1/2 hours
Christmas Cake	140 - 150	1	4 - 4 1/2 hours
Gingerbread	150 - 160	1 or 2	1 - 1 1/2 hours
Shortbread	150	2 or 3	1 1/4 - 1 1/2 hours
Biscuits	170 - 180	2 or 3	15 - 25 mins depending on recipe
Tray Bakes & Tea Breads	180 - 190	2 or 3	30 mins - 1 1/2 hours depending on recipe
Shortcrust Pastry	200	2 or 3	Small Tarts 20 - 25 mins depending on recipe, Pies 45 - 50 mins depending on recipe
Rich Shortcrust	190	2 or 3	25 mins
Flaky/Puff Pastry	220 - 230	2 or 3	8 - 10 mins depending on recipe
Choux Pastry	200	2 or 3	25 - 35 mins
Miscellaneous			
Yorkshire Pudding - Large	220	2 or 3	45 mins
Yorkshire Pudding - Individual	220	2 or 3	20 - 25 mins
Soufflés	190	2	45 mins

Fan Oven

• Fan Oven • Fan Oven • Fan Oven • Fan Oven • Fan Oven • Fan Oven • Fan Oven •

- The left hand lower oven is a fan oven, which means that the air is circulated to create an even temperature throughout. In most cases food requires a lower oven temperature when cooked in ovens by approximately 10°C - 20°C.
- The cooking charts are a general guide but times and temperatures may vary according to individual recipes.
- The meat sections should be used as a guide but may vary according to the size, shape of joint on or off the bone.
- Thaw frozen joints thoroughly before cooking them.
- The times are for open roasting. If covered with foil allow for extra time..
- The turkey/chicken is cooked when the juices run clear when pierced with a skewer. If the juices are still pink continue to cook checking every 15 minutes until juices run clear.





FOOD	SETTING °C	APPROXIMATE COOKING TIME
Fish		
Whole Fish e.g. trout, mackerel	170	25 - 30 mins depending on size
Steaks	170	20 - 25 mins depending on thickness
Oven-fried fish	170	25 mins depending on packet instructions
Salmon (2.7kg)	140 - 150	15 - 18 mins per 450g
Meat & Poultry		
Beef	170 - 180	30 mins per 450g + 30 mins over (medium rare)
Lamb	170 - 180	25 mins per 450g + 25 mins over
Pork	170 - 180	30 - 35 mins per 450g + 35 mins over
Chicken	170 - 180	20 - 25 mins per 450g + 20 mins over
Turkey	150 - 160	15 - 18 mins per 450g + 15 mins over
Duck & Goose	170 - 180	25 mins per lb + 25 mins over
Casserole	130 - 140	1 1/2 - 3 hours depending on recipe
Puddings		
Milk Puddings	140	2 hours
Baked Custard	140	35 mins
Baked Sponge Pudding	160	45 mins - 1 hour using raw fruit
Fruit Crumble	170 - 180	45 mins - 1 hour

FOOD	SETTING °C	APPROXIMATE COOKING TIME
Meringue Toppings	130	45 mins
Meringues	80 - 90	3 - 4 hours - Turn meringues over as soon as they are set
Yeast Mixtures		
Bread - loaves	200 - 210	30 - 45 mins
Bread - rolls	200 - 210	15 - 20 mins
Chelsea Buns etc.	180	25 - 35 mins
Cakes, Pastries, Biscuits & Scones		
Small Cakes	170 - 180	20 - 25 mins
Victoria Sandwich	160 - 170	25 - 30 mins
Swiss Roll	200 - 210	7 - 10 mins
Fatless Sponge (180mm)	170	20 mins
Scones	200 - 210	10 - 15 mins
Maderia Cake	160	1 hour - Place on a piece of citron peel after 20 mins
Med. Rich Fruit Cake	130	2 - 2 1/2 hours
Christmas Cake (205mm)	130	4 - 4 1/2 hours
Gingerbread	130 - 140	1 - 1 1/2 hours
Shortbread	140 - 150	1 1/4 - 1 1/2 hours
Biscuits	130 - 180	15 - 25 mins depending on recipe
Tray Bakes & Tea Breads	160 - 170	30 mins - 1 1/2 hours depending on recipe
Shortcrust Pastry	190	Small Tarts 20 - 25 mins depending on recipe, Pies 45 - 50 mins depending on recipe
Rich Shortcrust	180	25 mins
Flaky/Puff Pastry	210	8 - 10 mins depending on recipe
Choux Pastry	190 - 200	25 - 35 mins
Miscellaneous		
Yorkshire Pudding - large	200	45 mins
Yorkshire Pudding - individual	200	20 - 25 mins
Soufflès	170 - 180	45 mins

THE MINUTE TIMER

The minute timer works separately from the time of day clock and can be set to time periods from 1 minute to 23:59 hours. Only a one handed operation is required.

SETTING THE MINUTE TIMER

1. Press the **MINUTE TIMER**  button the bell symbol and **0.00** will be displayed. Set the required time by using the plus **+** and minus **-** buttons.
2. After 5 seconds the display will go back to showing the time of day, the bell symbol will remain steady and the set time will immediately start to count down, by pressing the minute timer button the display shows the time remaining.
3. At the end of the set time, a beep will sound, the bell symbol will flash and continue for 2 minutes unless cancelled by pressing the **MINUTE TIMER**  button or **MANUAL**  button.
4. The setting can be cancelled by pressing the **MINUTE TIMER**  and minus **-** button and running the time back to **0.00**.

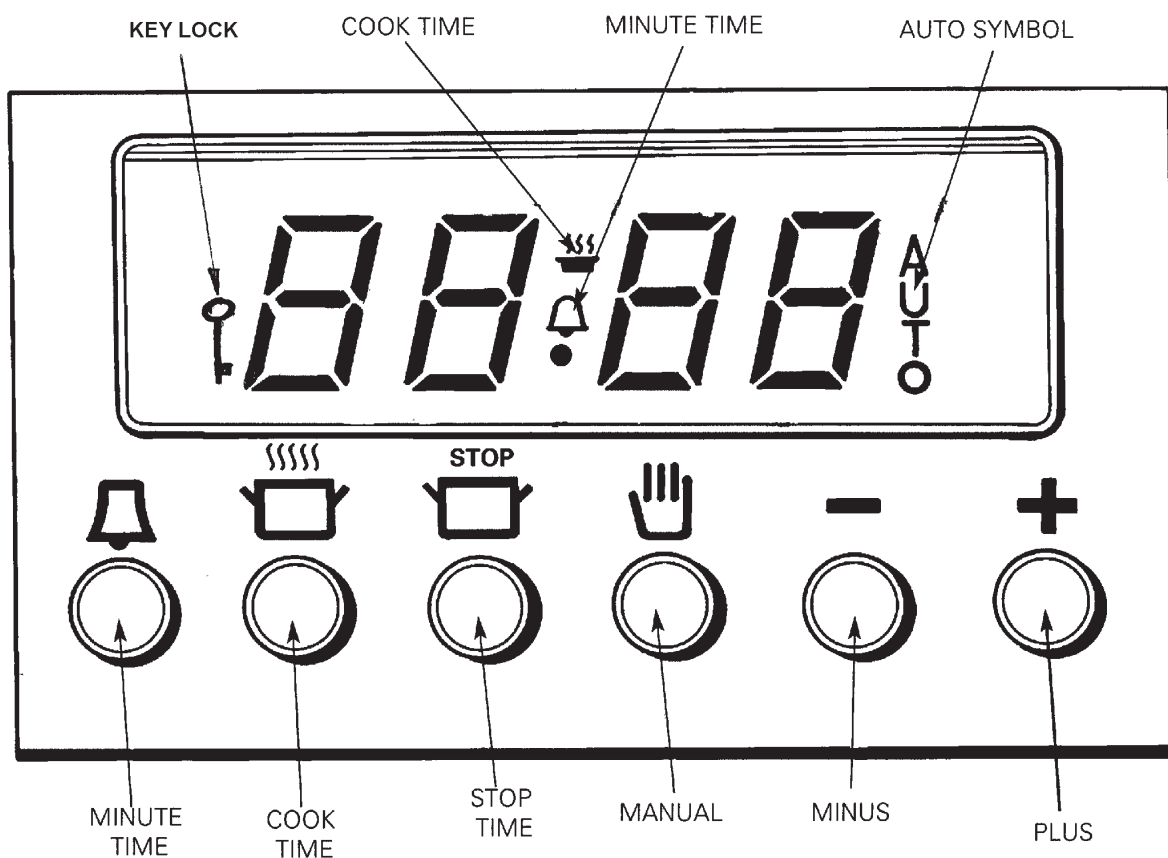

FIG. 16

DESN 512657

AUTOMATIC COOKING CONTROL

This can be used to set an automatic cooking programme in the **bottom left fan oven only**. It switches the electricity on and off at the pre-set times.

The maximum length of cooking programme which can be set is 23 hours and 59 minutes e.g. delay time + cooking time = maximum 23 hours and 59 minutes.

Before setting a programme check that the clock is telling the correct time of day, and have the following information to hand:

- The length of time the food needs to cook.
- The time that the food is to finish cooking.
- The oven control setting required.



SETTING THE AUTOMATIC COOKING PROGRAMME

Either the **STOP TIME**  or the **COOK TIME**  buttons can be pressed first.

Each setting will remain displayed for 5 seconds before changing back to display the time of day.



An example of setting a programme using the cook time button first.

The food needs 2 hours and 30 minutes at 140°C and is required to be ready by 18.00 hours.

1. Place the food on the correct shelves in the oven.
2. Check that the clock is telling the correct time of day.
3. Press the **COOK TIME**  button and then the plus + or minus - buttons until 2 hours 30 minutes is displayed.
4. Press the **STOP**  button and then the plus + or minus - buttons until 18.00 hours is displayed.
5. Set the oven temperature control to 140°C.
6. 5 seconds after setting, the clock will display the time of day and **AUTO**.
7. When cooking starts the **COOK TIME**  symbol illuminates and remains throughout cooking.
8. When the cooking has finished, a beep will sound and continue for 2 minutes, unless cancelled manually.

The **AUTO** symbol will flash. To cancel these and return to manual press **MANUAL COOK**  button twice.

SETTING AN END TIME ONLY , AUTOMATICALLY

1. Place the food on the correct shelves in the oven.
2. Press the **STOP**  button until the time at which cooking is to end, appears on the display.
3. Set the oven temperature control.
Cooking will start immediately and the **COOK TIME**  symbol will illuminate and remain throughout cooking.
4. When the cooking is finished, a beep will sound and continue for 2 minutes unless cancelled manually.
The **AUTO** symbol will flash.
5. To cancel and return to manual mode, press the **MANUAL COOK TIME**  twice.

Programmes can be adjusted at any time by pressing the appropriate buttons and the plus + and minus - buttons as described previously.

CANCELLING A PROGRAMME



The cooking programme can be cancelled by pressing the **COOK TIME**  button and the minus - buttons until **0.00** appears in the display.

Press the **MANUAL COOK TIME**  button to return the oven to manual mode.



NOTE: When an automatic cooking programme has been set, the time of day clock cannot be adjusted.

KEY LOCK - If this mode is activated, a program can be set but it will not be activated, i.e. **ON** and **OFF** times can be set, but time will not switch the ovens on.

TO ACTIVATE KEY LOCK FUNCTION

1. Ensure the timer is in manual mode (no active programs).
2. Hold the **MINUTE TIMER**  button and **COOK TIME**  button simultaneously, for approximately 8 seconds. The display will read **ON**.
3. Press the **+** plus button. The display reads **OFF** and the key symbol appears. After approximately 5 seconds the time of day reappears next to the key symbol. The key lock is now activated.

TO DE-ACTIVATE KEY LOCK FUNCTION

1. Ensure the timer is in manual mode.
2. Hold the **MINUTE TIMER**  button and **COOK TIME**  button simultaneously for approximately 8 seconds, the display will read **OFF**.
3. Press the **+** plus button. The display reads **ON**, the key symbol disappears. After approximately 5 seconds the time reappears and the key lock is now deactivated.

CLEANING & CARING FOR YOUR COOKER

General

- **Always switch OFF at the mains before cleaning.**
- Use as little water as possible.
- Do not use CAUSTIC CLEANING SOLUTIONS
- **Do not use a steam cleaner to clean this cooker.**
- If milk or fruit juice or anything containing acid, is spilt on the cooker, wipe it up immediately.
- Wipe up any spills as they occur and transfer pans to other burners to continue cooking.
- Clean off any condensation streaks on the front plate around the oven doors or the vitreous enamel maybe permanently discoloured.
- **TAKE CARE NOT TO DAMAGE THE OVEN THERMOSTAT PHIAL OR THE HOTPLATE IGNITION ELECTRODES DURING CLEANING.**
- After cleaning, ensure all parts are thoroughly dry before replacing.
- When re-fitting the burner caps and burner heads make sure that they are properly located.
- **THE FOLLOWING PARTS ARE NOT DISHWASHER SAFE:**
Aluminium burner heads (LHR, CF, RHR, RHF).

IMPORTANT: AGA recommend Vitreous Enamel Association approved cleaners for cleaning the vitreous enamelled surfaces of this product.

But they are unsuitable for use on: chrome and stainless steel components, hand-rails and their brackets.

THE COOKER CANNOT BE MOVED ONCE INSTALLED.

DO NOT ATTEMPT TO MOVE THE COOKER BY PULLING THE HANDRAIL OR DOORS

CLEANING & CARING FOR YOUR COOKER

<u>COOKER PART AND FINISH</u>	<u>CLEANING METHOD</u>
<p><u>Vitreous Enamel</u></p> <p>Grill - base only Hotplate Control panel Pan supports Roasting tin Grill pan Conventional, fan and simmering oven - base only Door liners Front of cooker Doors</p>	<p>Clean with a damp cloth and hot soapy water. Stubborn stains can be removed with mild cream, paste or liquid cleaners, or by gently rubbing with a well moistened, liberally soaped very fine steel wool pads e.g. Brillo.</p> <p>The pan supports, roasting tin and baking tray may <u>OCCASIONALLY</u> be cleaned in a dishwasher.</p> <ul style="list-style-type: none"> o Check that the cleaning agent is approved by the (VEA) Vitreous Enamel Association.
<p><u>High Temperature Protective Coating</u></p> <p>Hand rail bracket Burner caps Burner heads Plinth</p>	<p>Clean with a damp cloth and hot soapy water.</p> <p style="text-align: center;"><u>IMPORTANT:</u> <u>DO NOT USE ABRASIVES</u></p>
<p><u>Glass</u></p> <p>Grill element cover Splashback</p>	<p>As for enamel cleaning above. Polish with a clean dry cloth or kitchen roll.</p>
<p><u>Stainless Steel</u></p> <p>Door catches Handrail</p>	<p>Use warm soapy water or a proprietary stainless steel or chrome cleaner.</p>
<p><u>Chromium Plated</u></p> <p>Oven and grill shelves Shelf supports Grill pan handle Grill pan grid</p>	<p>Wipe with a damp cloth and soapy water. A well moistened liberally soaped very fine steel wool pad e.g. Brillo, or stainless steel cleaner may be used.</p>
<p><u>Plastic</u></p> <p>Grill pan handle Control knobs Timer facia & controls Neons</p>	<p>Wipe with a damp cloth and hot soapy water. Stubborn stains may be removed with a cream cleaner carefully applied.</p>

COOKER PART AND FINISH

CLEANING METHOD

Heat-Clean Enamel

Fan oven, Conventional oven, Simmering oven: sides top and back
Grill compartment: sides and back

This special enamel has a continuous cleaning action, which works best if a pattern of low and high temperature cooking is followed. By using low temperature roasting, excessive fat splashes can be avoided. Should any excessive staining occur, immediately clean the area with hot water containing detergent, and a nylon washing-up brush. Resistant stains require the oven to be run at 210°C for 2 hours.

DO NOT ANY ANY CLEANING MATERIAL WHICH ANY CLOG THE PORES OF THE SPECIAL COATING e.g. PASTES AND POWDERS, SOAP-FILLED PADS, WIRE WOOL, SPRAY CLEANERS, BRUSH-ON OVEN CLEANERS, CAUSTIC SOLUTIONS, METAL SCRAPERS/KNIVES, AND PREVENT THE CONTINUOUS CLEANING ACTION.

Aluminium

Right & left rear outer burner caps
Right front outer burner cap
Centre front outer burner cap

As for enamel cleaning. Do not place in a dishwasher

NOTE: Care must be taken to prevent cleaning materials, water or dirt, from entering and blocking the burner head, ports and especially the gasway. Remove any blockage with a fine needle or nylon brush.

Non-Stick Coating

Griddle plate

Soak and wash in hot soapy water.

DO NOT USE ABRASIVES OR PLACE IN A DISHWASHER.

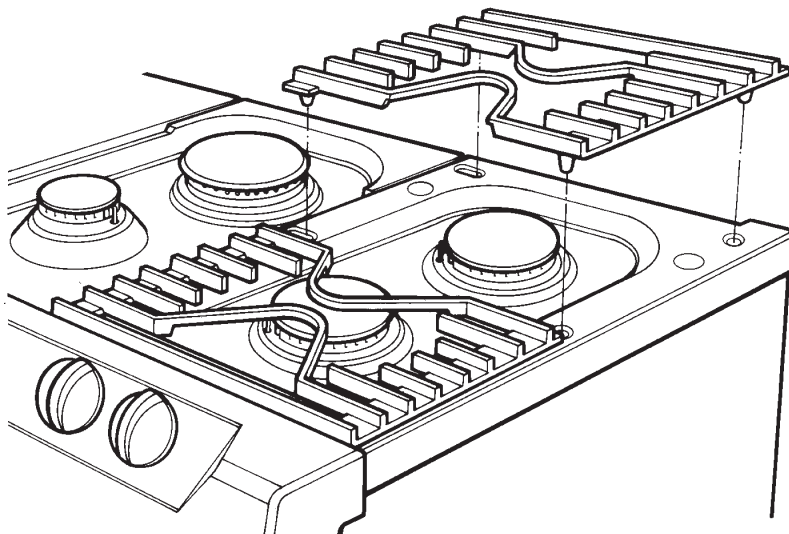
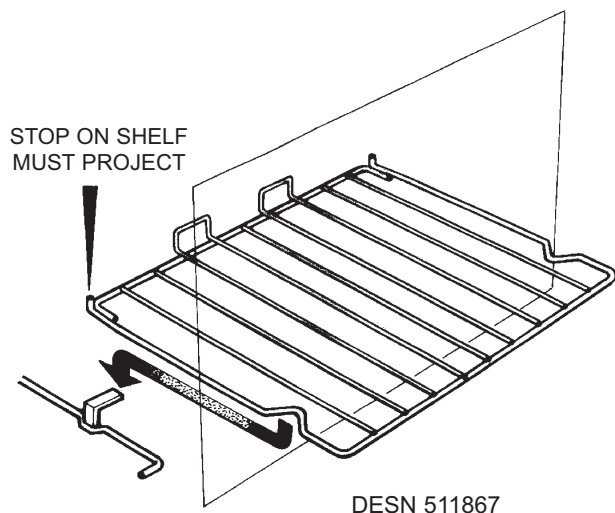

FIG. 17

DESN 512935 A

Oven Shelves - These shelves are designed to slide out



Refit as follows:
Locate in guide as above.

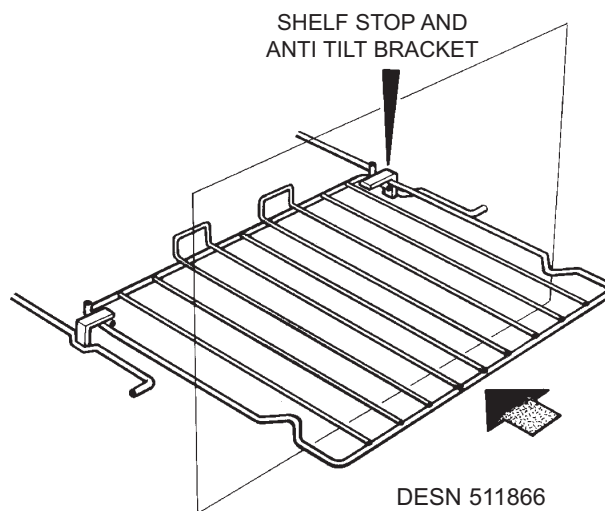

Please Note: Shelf slides out to stop position.

Fig. 18A

Grill Shelf - operates as oven shelves

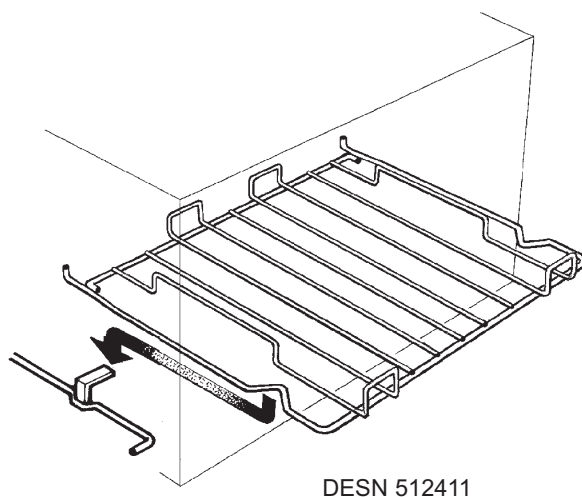

Fig. 18B

ASSEMBLY OF RAPID AND SEMI-RAPID BURNER

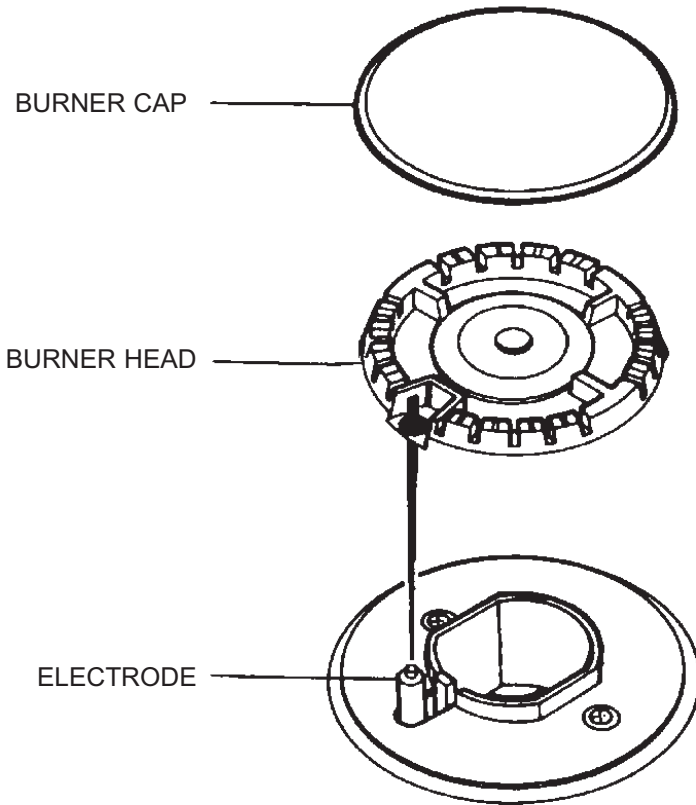

Fig. 19

DESN 511618

FITTING BURNER CAP - RAPID AND SEMI-RAPID BURNER

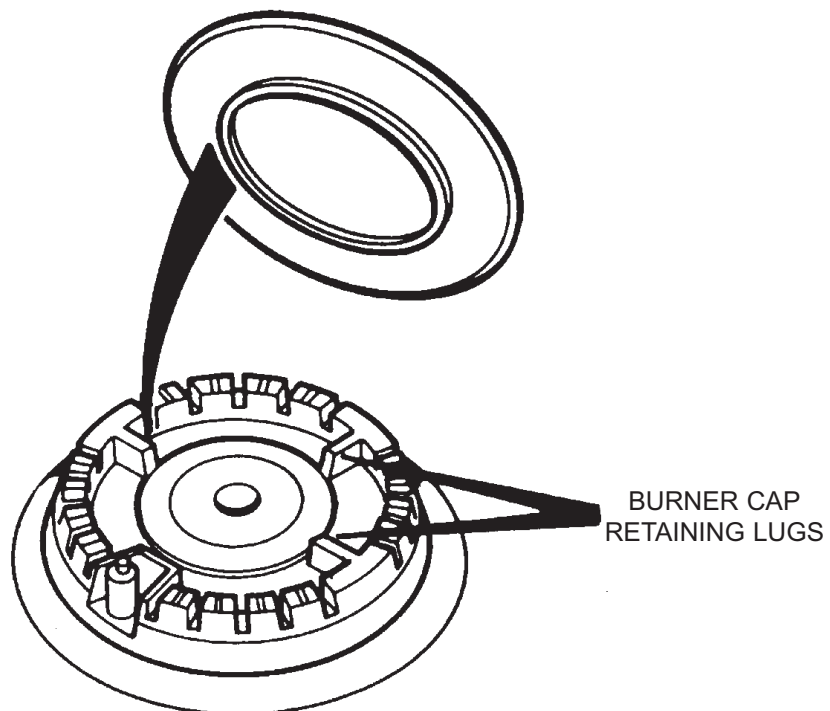

Fig. 20

DESN 511617

WOK BURNER

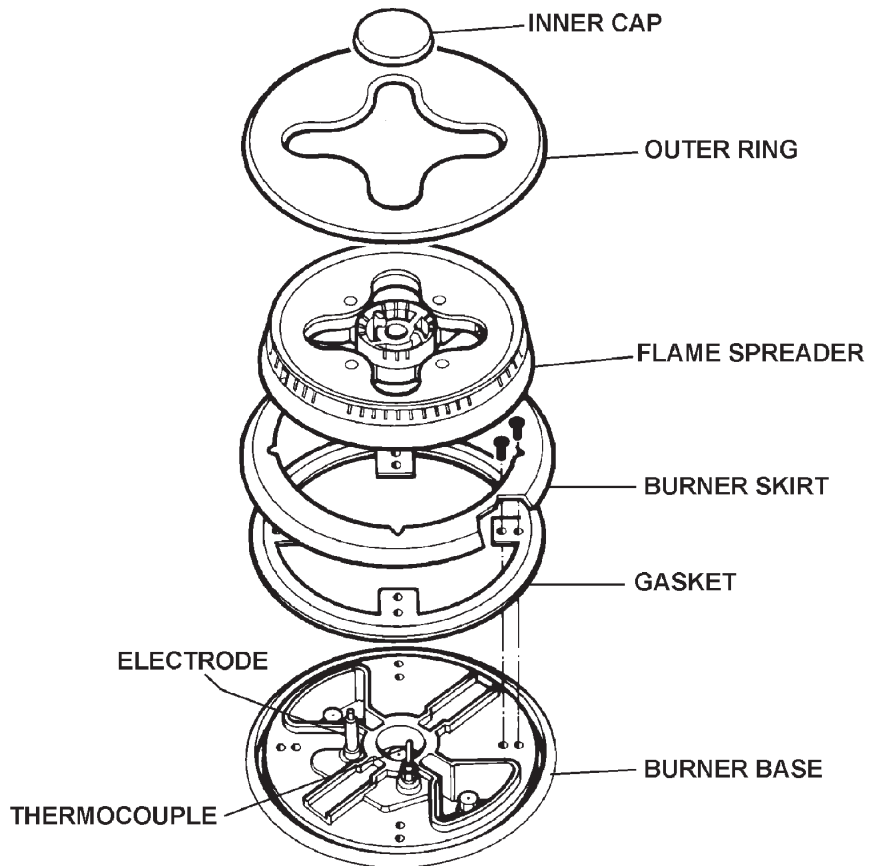

Fig. 21

DESN 513512

ULTRA RAPID BURNER

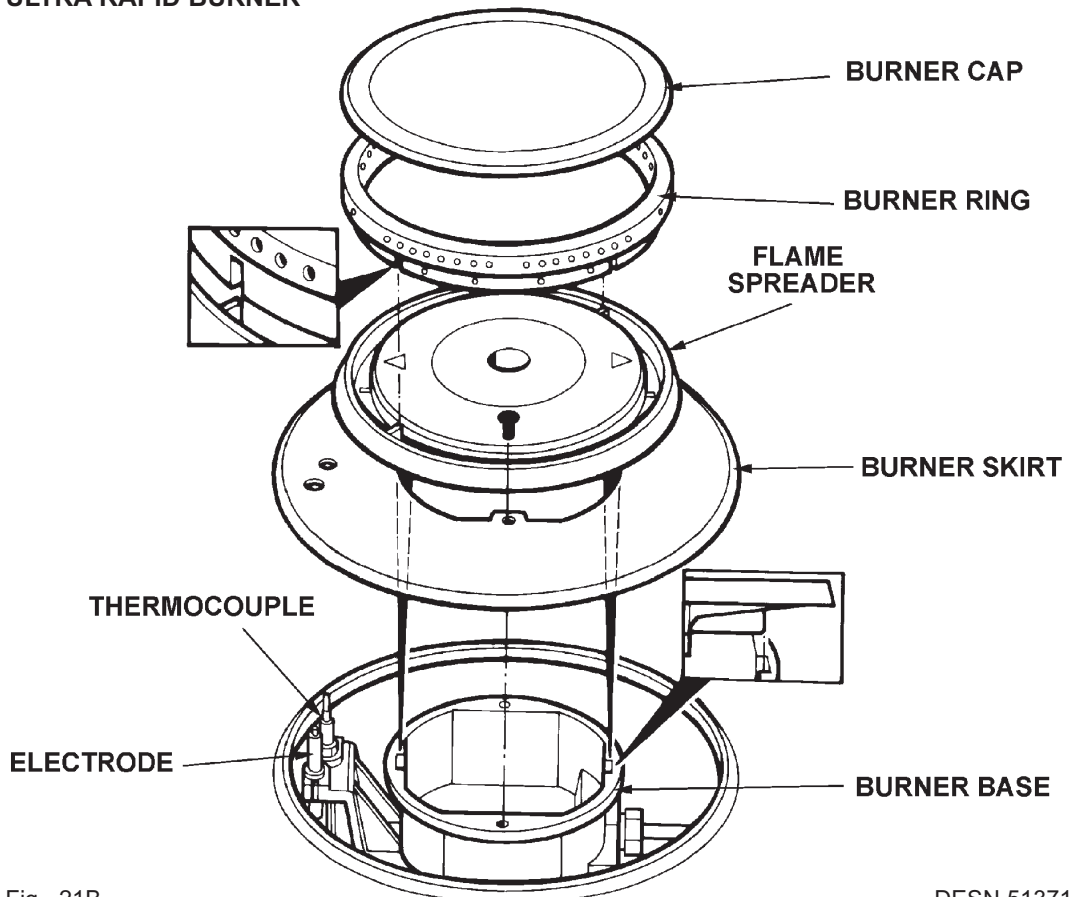

Fig. 21B

DESN 513714

Servicing

Section

Remember, when replacing a part on this appliance, use only spare parts that you can be assured conform to the safety and performance specification that we require. Do not use reconditioned or copy parts that have not been clearly authorised by AGA.

SERVICING

- In the event of your appliance requiring maintenance, please call AGA Service or contact your authorised distributor/stockist.
- Your cooker must only be serviced by a qualified Gas Safe Registered Engineer from an authorised distributor or stockist.
- Do not alter or modify the cooker.
- Only the spares specified by the manufacturer are to be fitted.

WARNING: WHEN SERVICING OR REPLACING GAS CARRYING COMPONENTS, DISCONNECT GAS SUPPLY TO APPLIANCE AND AFTER COMPLETION CHECK APPLIANCE FOR GAS SOUNDNESS.

WARNING: WHEN SERVICING OR REPLACING COMPONENTS, ISOLATE THE APPLIANCE FROM THE ELECTRIC SUPPLY AND BEFORE RECONNECTING, CHECK FOR ELECTRICAL SUPPLY.

A. TO REMOVE HOTPLATE

1. Isolate from electric supply.
2. Remove pan supports and burner caps. (See Fig. 22)
3. Remove burner fixing screws (14) and hotplate fixing nuts (8).
4. Lift off burner fixing rings (6).
5. Lift off hotplate castings in the following order: left hand, right hand and centre. (See Fig. 23).

NOTE: Each hotplate casting has an earth lead. Each lead must be disconnected before completely removing hotplate casting. (See Fig. 24).

6. Re-assemble in reverse order.

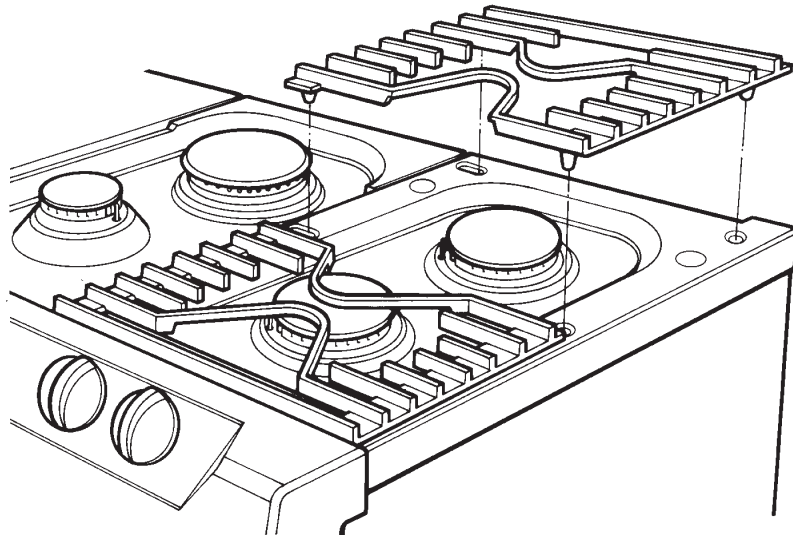

Fig. 22

DESN 512935 A

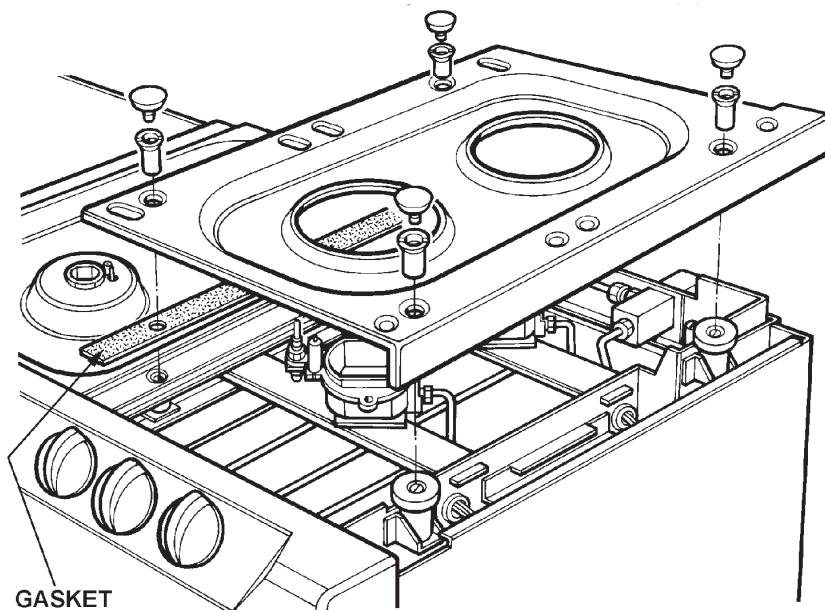

Fig. 23

DESN 512393 C

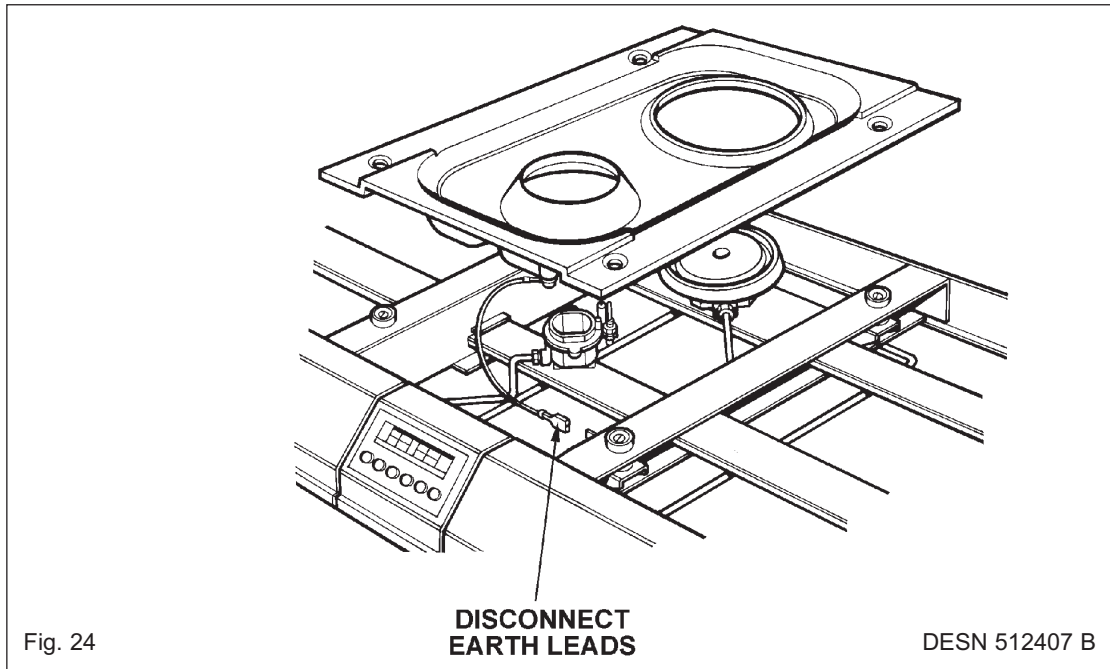

Fig. 24

DESN 512407 B

B. TO REMOVE SIDE PANELS

1. Isolate from electric supply.
2. Lower the cooker onto the rollers by turning the adjusting feet fully anti-clockwise.
NOTE: It may be necessary to disconnect the flexible gas connection to allow the cooker to be withdrawn from between the kitchen units.
3. Roll the cooker slightly forward, unhook the safety chain and disconnect the flexible hose.
4. Remove rear fixing screws (3) and slide side panel back and out.
5. Re-assemble in reverse order.

C. TO REMOVE FACIA CASTINGS

1. Isolate from electric supply.
2. Proceed as 'TO REMOVE HOTPLATE CASTINGS'.
3. Pull off control knobs.
4. Remove control panel fixing screws (4 per casting) (See Fig. 25). When removing the screws support the casting.
NOTE: When removing the castings, the oven indicator neons require disconnecting from the facia, hold the cables at their entry into the neon twist and pull, this will disengage the neon assembly. Be careful when refitting facia castings to position neon and wires correctly,

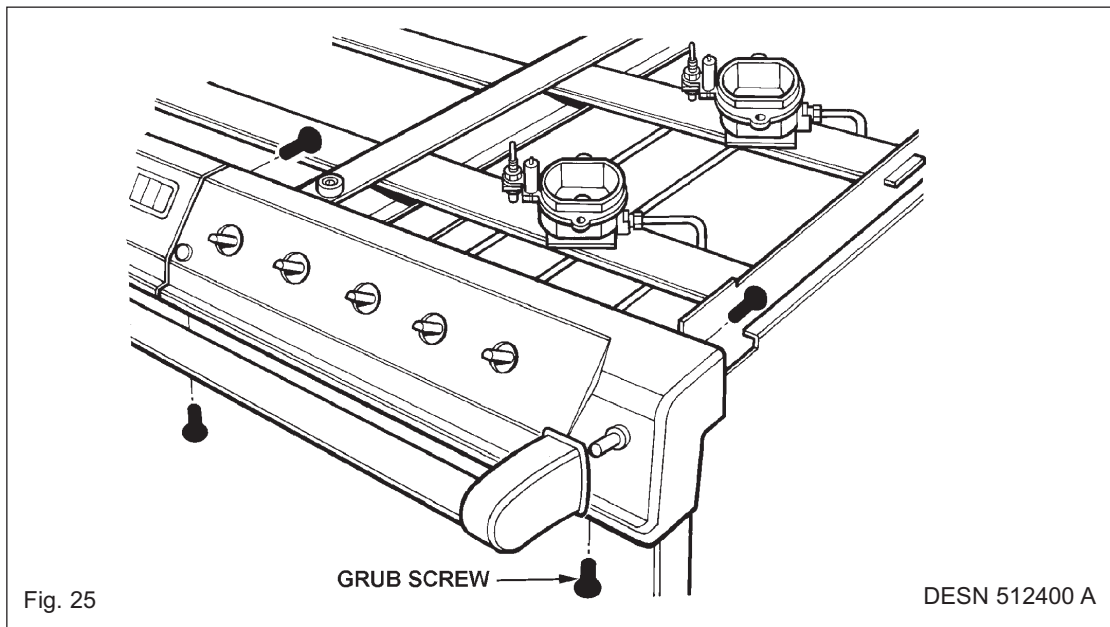

Fig. 25

DESN 512400 A

D. TO REMOVE HANDRAIL (SEE FIG. 25)

1. Loosen 2 grub screws, one at each end of hand rail (see fig. 25) using 2 1/2 mm socket key.
2. Slide handrail forwards, off locating studs.

E. TO REMOVE TIMER

1. Isolate from electric supply.
2. Proceed as 'TO REMOVE HOTPLATE CASTINGS'.
3. Remove fixing screws (4). Two top rear and two lower front of timer housing.
4. The timer assembly can now be lifted upwards sufficiently to disconnect electric cables at rear of timer. (See Fig. 26).

NOTE: Take care to identify cable connections.

5. Slacken timer fixing screw sufficiently to allow timer securing strip to slide out of fascia panel. (See Fig. 26).
6. Remove timer clamping screw, withdraw clamp and lift out timer. (See Fig. 27).
7. Re-assemble in reverse order.

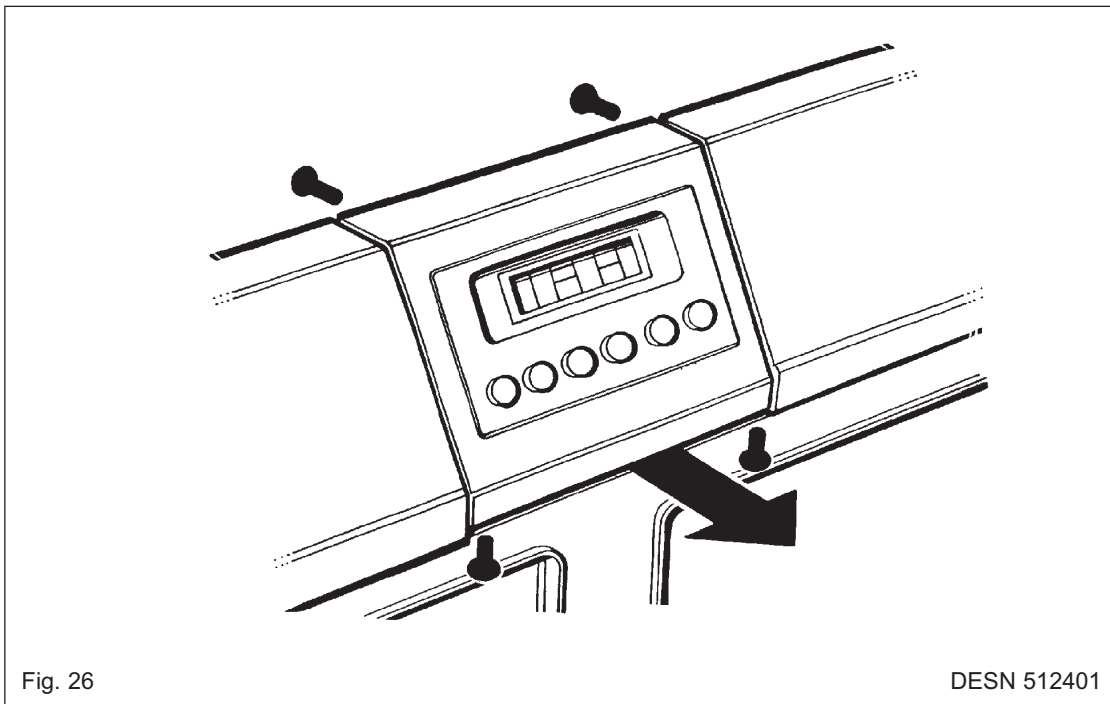

Fig. 26

DESN 512401

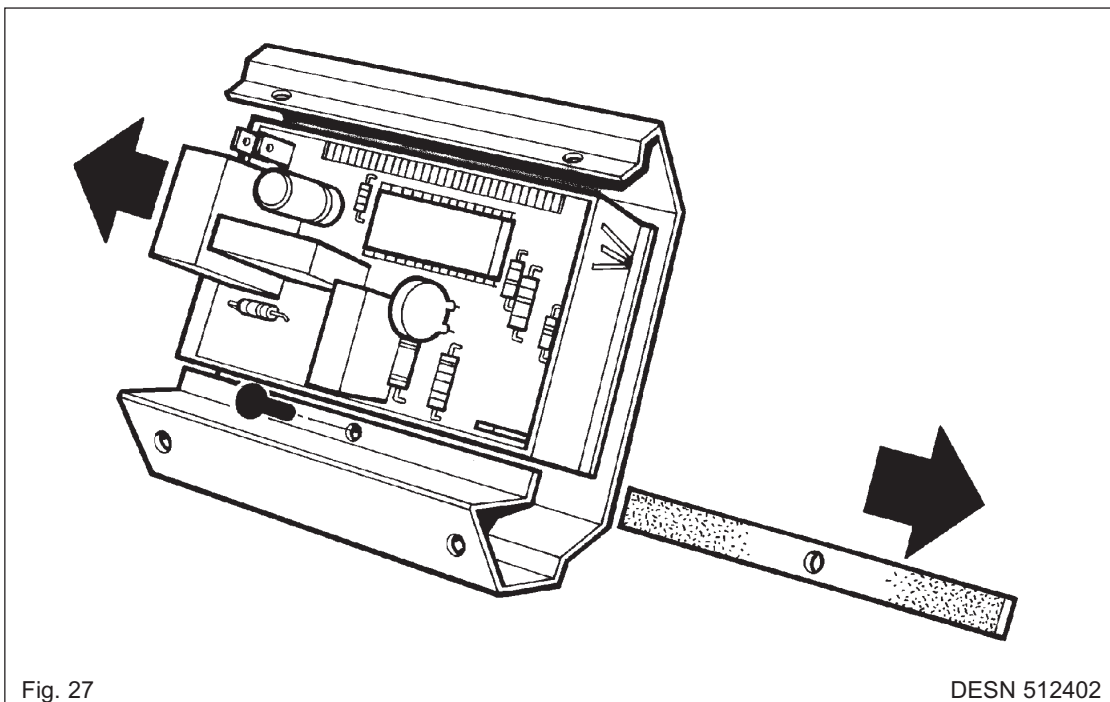
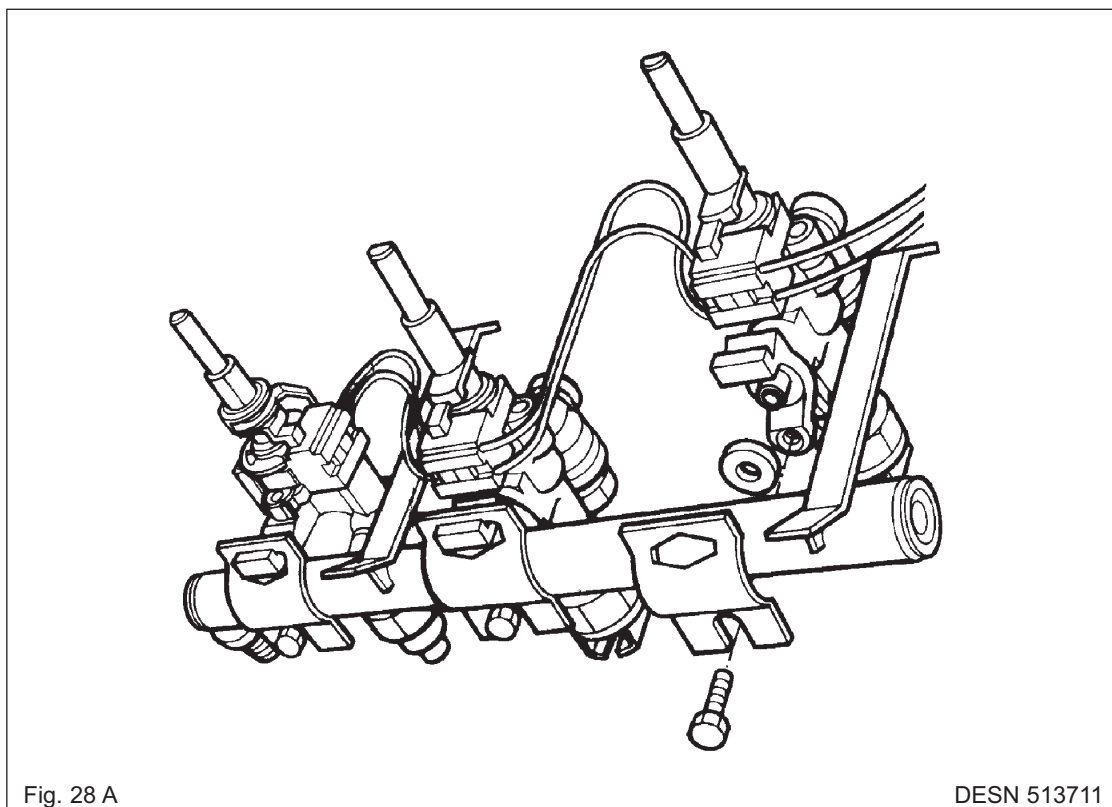
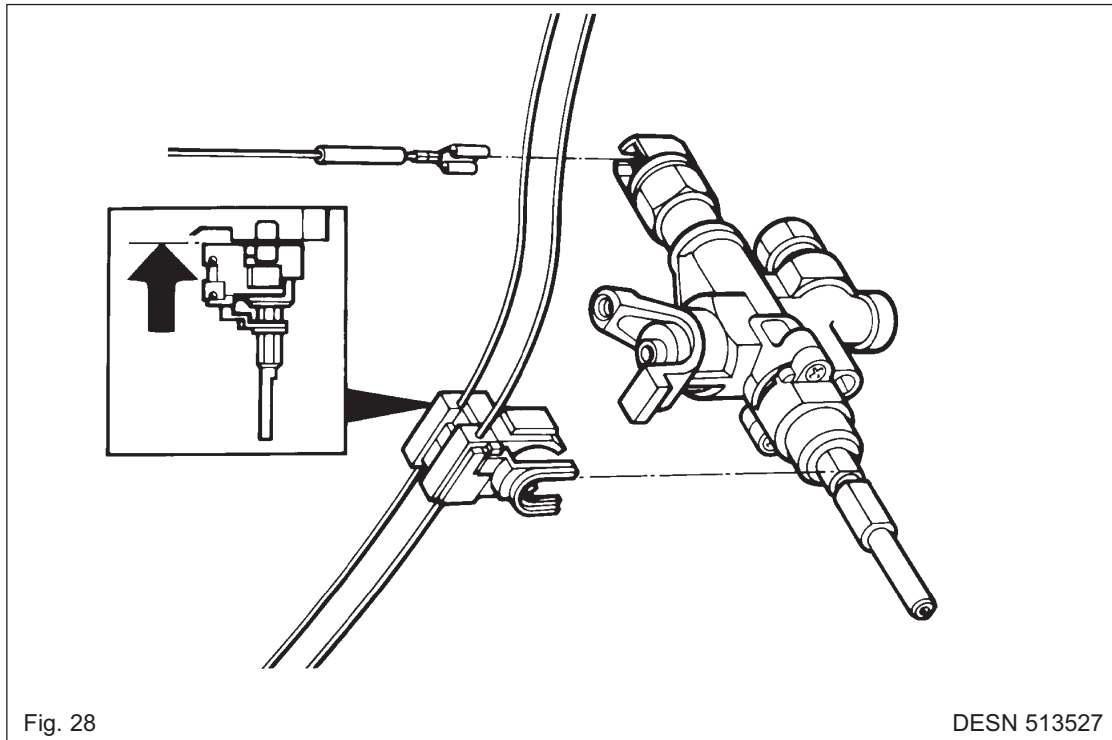

Fig. 27

DESN 512402

F. TO REMOVE GAS TAPS/IGNITION SWITCHES

1. Isolate from electric and gas supply.
2. Proceed as 'TO REMOVE HOTPLATE'.
3. Proceed as 'TO REMOVE FACIA'.
4. Disconnect gas rail feed pipe (19mm nut). (See Fig. 28).
5. Disconnect all gas connections to taps (5 nuts - 13mm, 14mm & 19mm).
6. Remove (4) screws fixing gas rail.
7. Disconnect ignition switch.
8. Lift complete gas rail assembly clear of appliance.
9. Remove bolt (1) and clamp fixing to gas rail and withdraw tap from gas rail.
10. Re-assemble in reverse order.



G. TO REMOVE GRILL REGULATOR

1. Isolate from electric supply.
2. Proceed as 'TO REMOVE FACIA CASTINGS'.
3. Remove two screws securing control to control mounting panel.
4. Withdraw control and cables taking care not to strain the cables.
5. Disconnect cables from the control.

NOTE: Take care to identify terminations.

6. Re-assemble in reverse order.

H. TO REMOVE OVEN THERMOSTATS

1. Isolate from electric supply.
2. Proceed as 'TO REMOVE GRILL REGULATOR'.
3. Remove (7) back panel screws.
4. Remove thermostat phial and capillary through back of cooker, note correct capillary route.
5. Re-assemble in reverse order.

I. TO REMOVE SPARK GENERATOR

1. Isolate from electric supply.
2. Proceed as 'TO REMOVE HOTPLATE CASTINGS'. Remove right hand casting only.
3. Slacken electric panel fixing screws (2). (See Fig. 29).
4. Lift panel off screws via keyhole slots.
5. Lift panel clear of appliance.
6. Disconnect electric cables to generator.
7. Disconnect electrode cables.
8. Slacken two screws securing generator to electrics panel to cooker frame and carefully withdraw generator.
9. Re-assemble in reverse order.

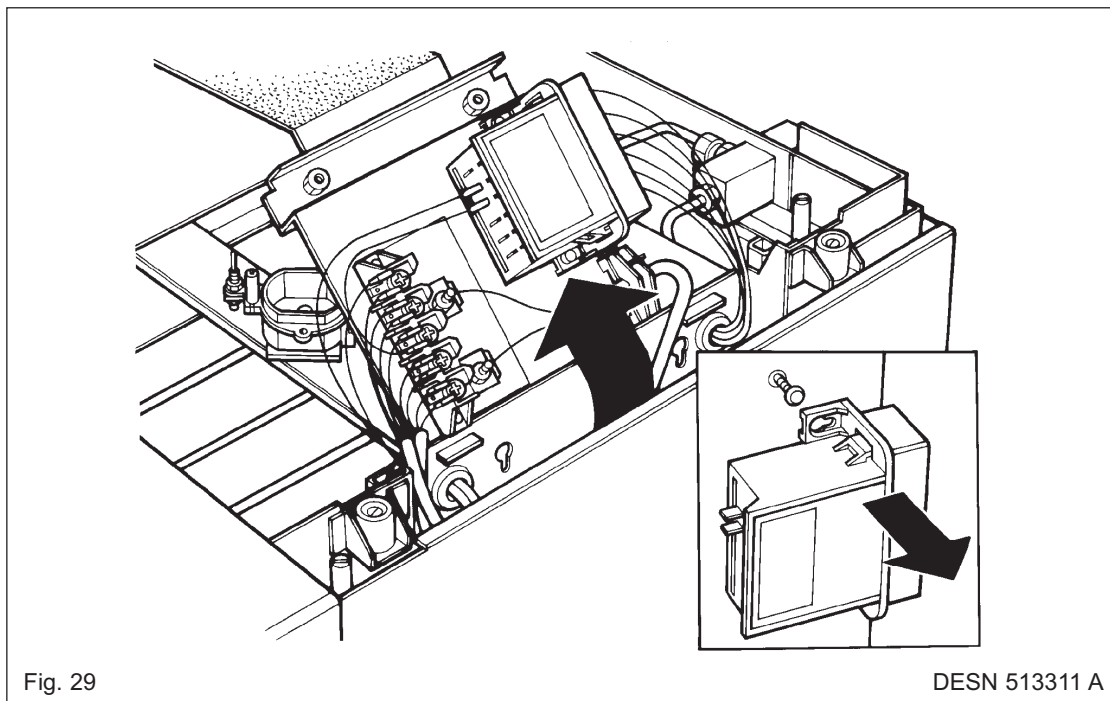
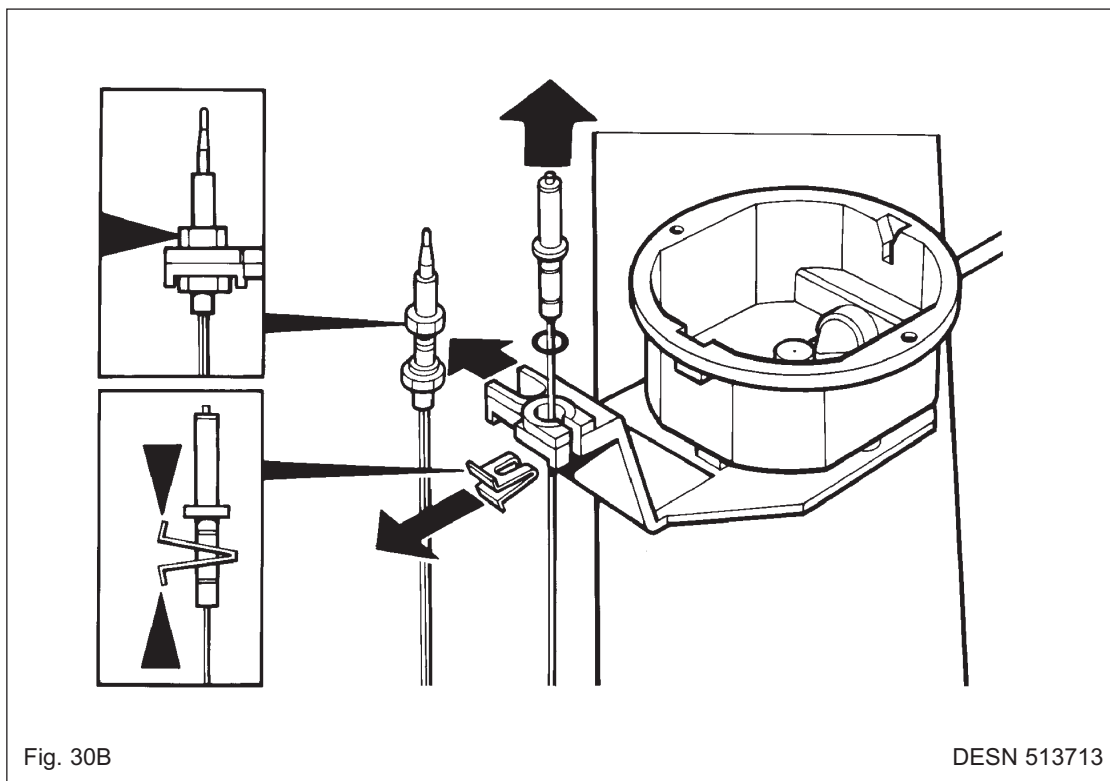
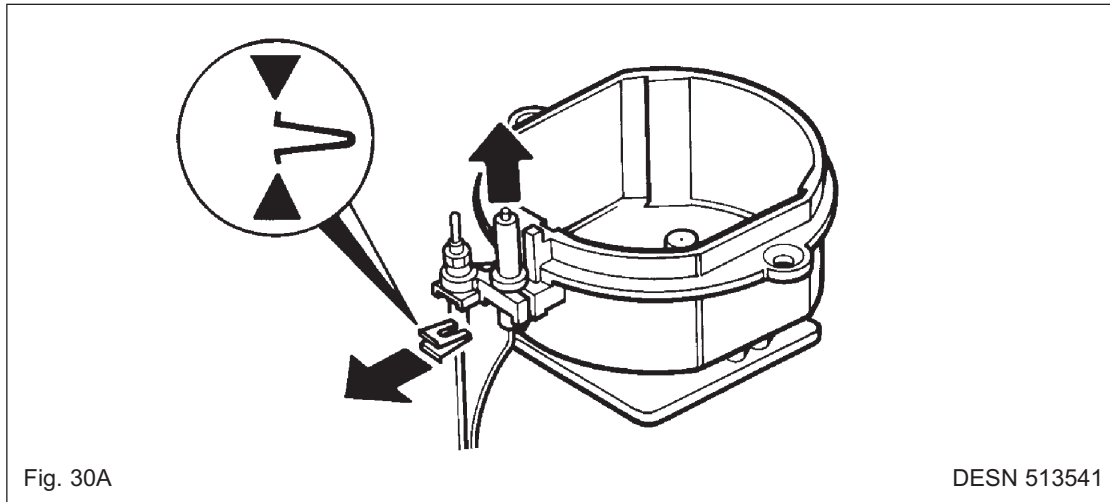

Fig. 29

DESN 513311 A

J. TO REMOVE ELECTRODES (LHR, CF, CR, RHR, RHF BURNERS)

1. Isolate from electric supply.
2. Proceed as 'TO REMOVE THE HOTPLATE'.
3. Proceed as 'TO REMOVE SPARK GENERATOR' disconnect the appropriate electrode lead.
4. Withdraw clip securing electrode to burner and withdraw lead and electrode (See Fig. 30).
5. Re-assemble in reverse order.



K. TO REMOVE ELECTRODE (LH BURNER)

1. Isolate from electrical supply.
2. Proceed as 'TO REMOVE HOTPLATE'.
3. Proceed as 'TO REMOVE SPARK GENERATOR'.
4. Disconnect the left hand burner pipe (13mm) and the inner burner pipe (13mm) using the special spanner.
5. Remove the burner and burner fixing plate, by unscrewing the (4) screws holding the burner mounting plate in place.
6. Turn burner over and remove electrode fixing clip. Withdraw electrode through top of burner checking on route of lead.
7. Re-assemble in reverse order, re-routing lead along the same path.

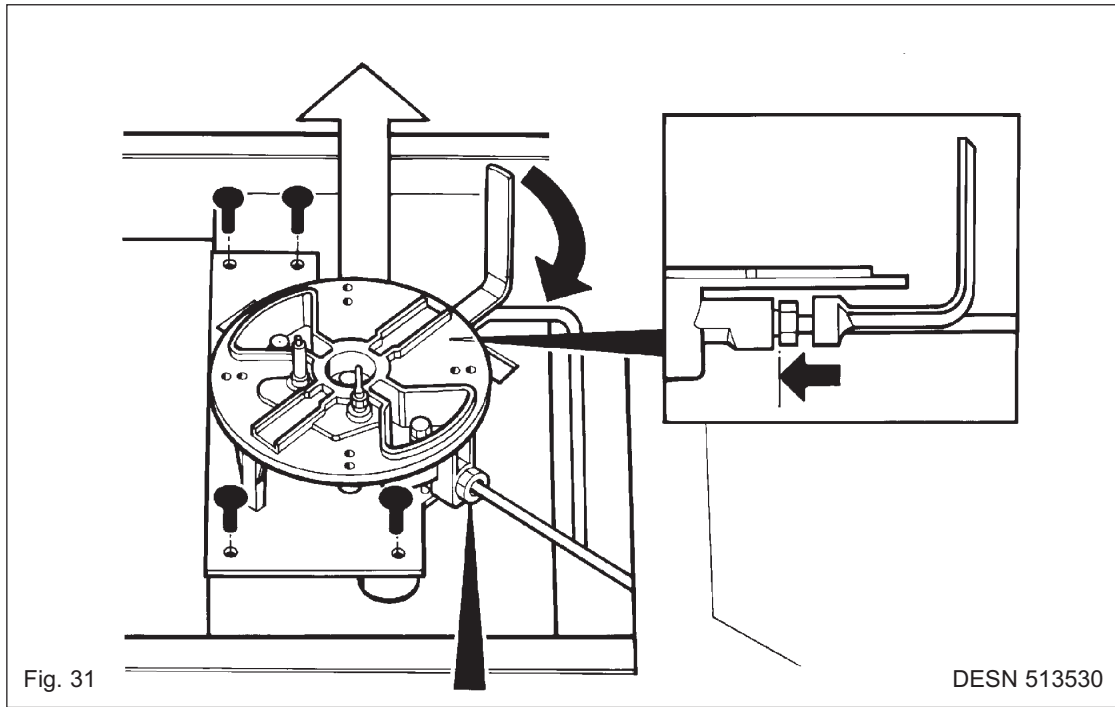

Fig. 31

DESN 513530

L. TO REMOVE THERMOCOUPLE (LHF BURNER)

1. Isolate from electric supply.
2. Proceed as 'TO REMOVE THE HOTPLATE'.
3. Undo the nut fixing the thermocouple in place.
4. Push the thermocouple down and pull out from under the burner.
5. Disconnect the other end of the thermocouple cable from the gas valve. This is a push on jack connector.
6. Re-assemble in reverse order.

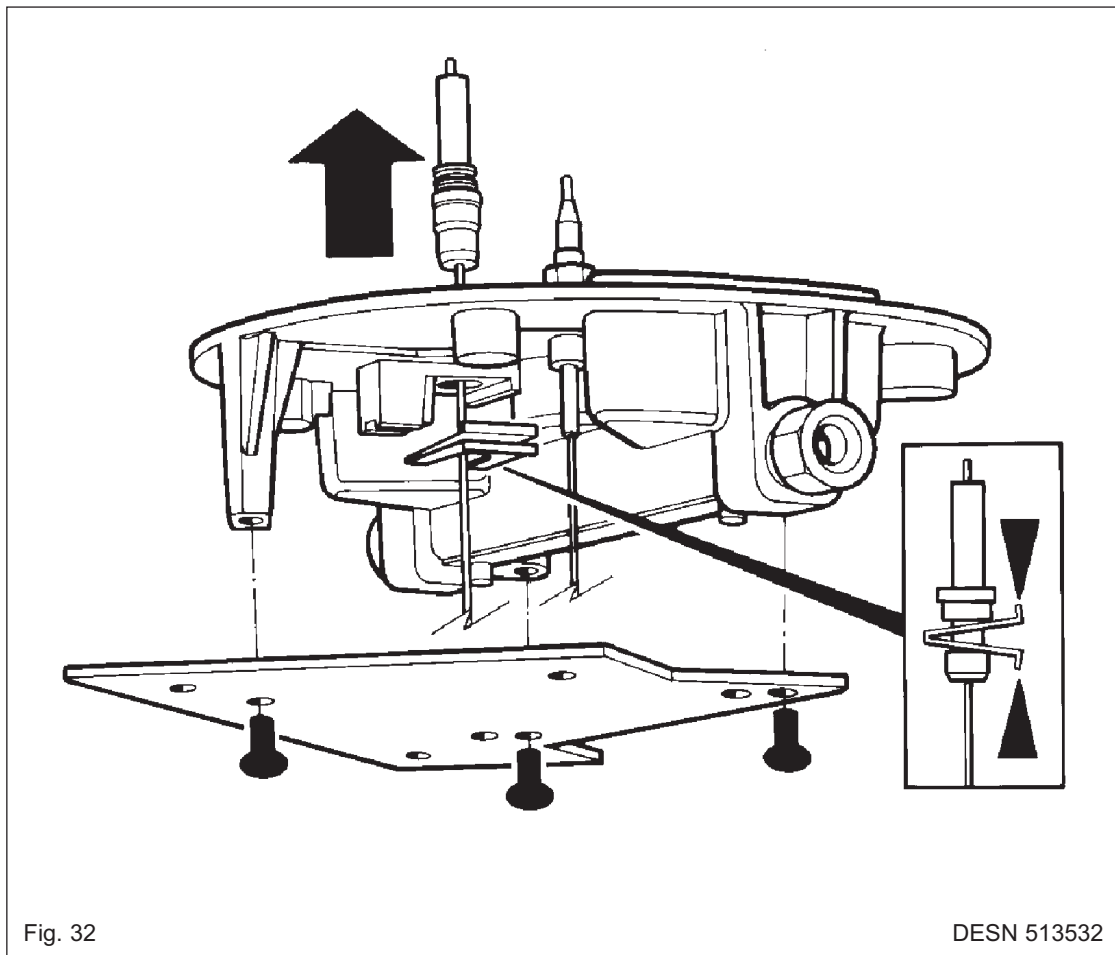
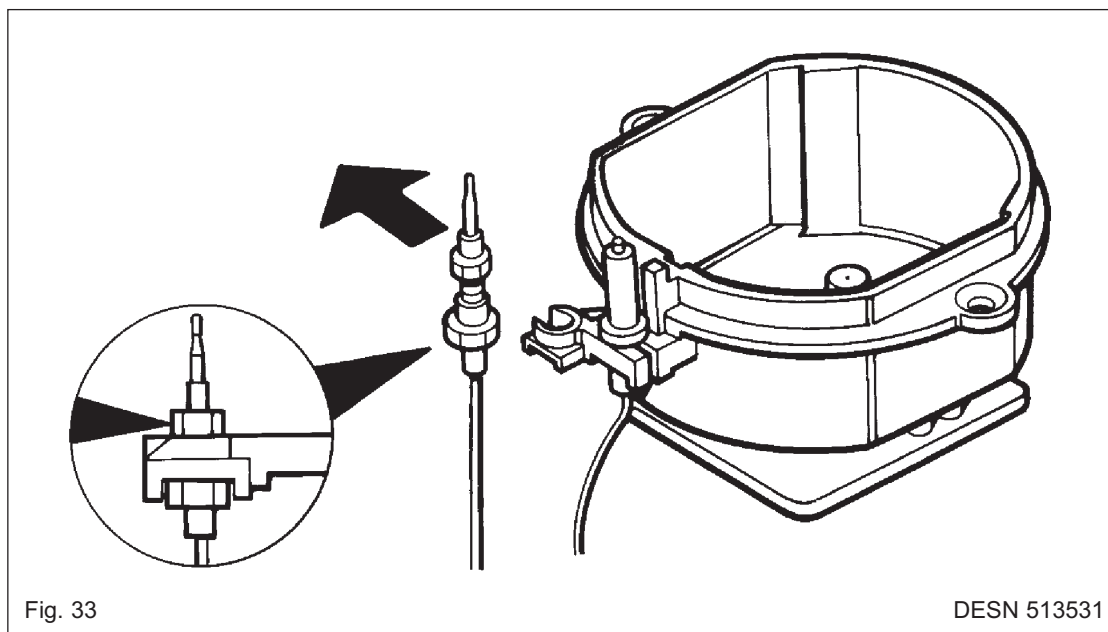

Fig. 32

DESN 513532

M. TO REMOVE THERMOCOUPLE (LHR, RHR, RHF BURNERS)

1. Isolate from electric supply.
2. Proceed as 'TO REMOVE THE HOTPLATE'.
3. Undo the nut fixing the thermocouple in place.
4. Push the thermocouple down and slide to the side to remove from the burner.
5. Disconnect the other end of the thermocouple cable from the gas valve, this is a push on electrical terminal.
6. Re-assemble in reverse order.



N. TO REMOVE OVEN AND GRILL LINERS - SEE FIG. 34

1. Remove LH and RH runners (4 screws per runner).
2. Remove runners and liners.

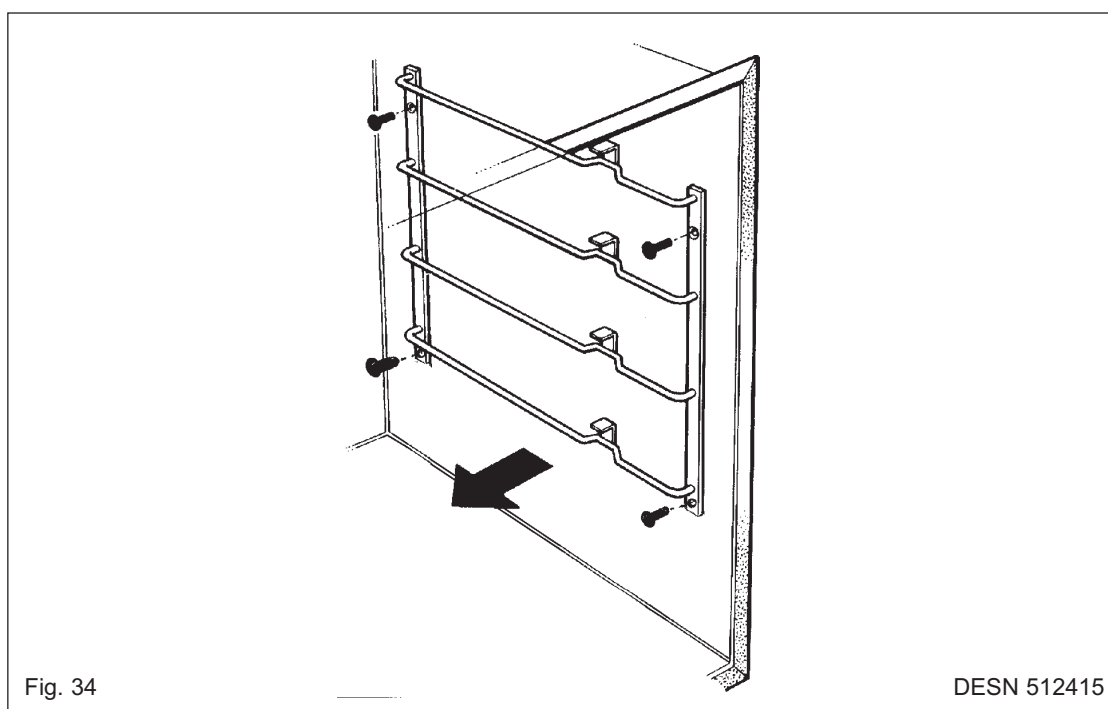

O. TO REMOVE ELEMENTS (RH OVENS)

1. Isolate from electrical supply.
2. Proceed as 'TO REMOVE OVEN AND GRILL LINERS'.
3. Remove oven base panel (1) screw at the rear of the oven.
4. Lift out base panel.
5. Remove oven element fixing screws (2) at the rear of the oven and flex elements to remove from location bracket, pull forwards to expose terminal connections.
6. Remove connection, make sure they do not fall down the back of the appliance.
NOTE: RH TOP OVEN has an element above the roof liner, remove in the same way as for base elements.
7. Re-assemble in reverse order.

P. TO REMOVE FAN OVEN ELEMENT

1. Isolate from electric supply.
2. Proceed as 'TO REMOVE OVEN LINERS'.
NOTE: You will only need to remove one side.
3. Remove (4) fan cover fixing screws and withdraw panel.
4. Remove 3 screws securing element to frame and carefully withdraw element until access can be made to the electrical terminals.
5. Disconnect terminals taking care not to allow the cable to fall down the rear of the appliance.
6. Re-assemble in reverse order.

Q. TO REMOVE OVEN FAN

1. Isolate from electric supply.
2. Proceed as 'TO REMOVE OVEN ELEMENT'.
3. Remove 4 fixing screws securing fan assembly to frame.
4. Withdraw fan assembly sufficiently to gain access to motor electrical terminals and disconnect cables.
5. Remove fan blade.
NOTE: Fan blade fixing nuts is LH thread.
6. Remove motor from mounting plate screws.
7. Re-assemble in reverse order.

WIRING DIAGRAM - AGA DC6

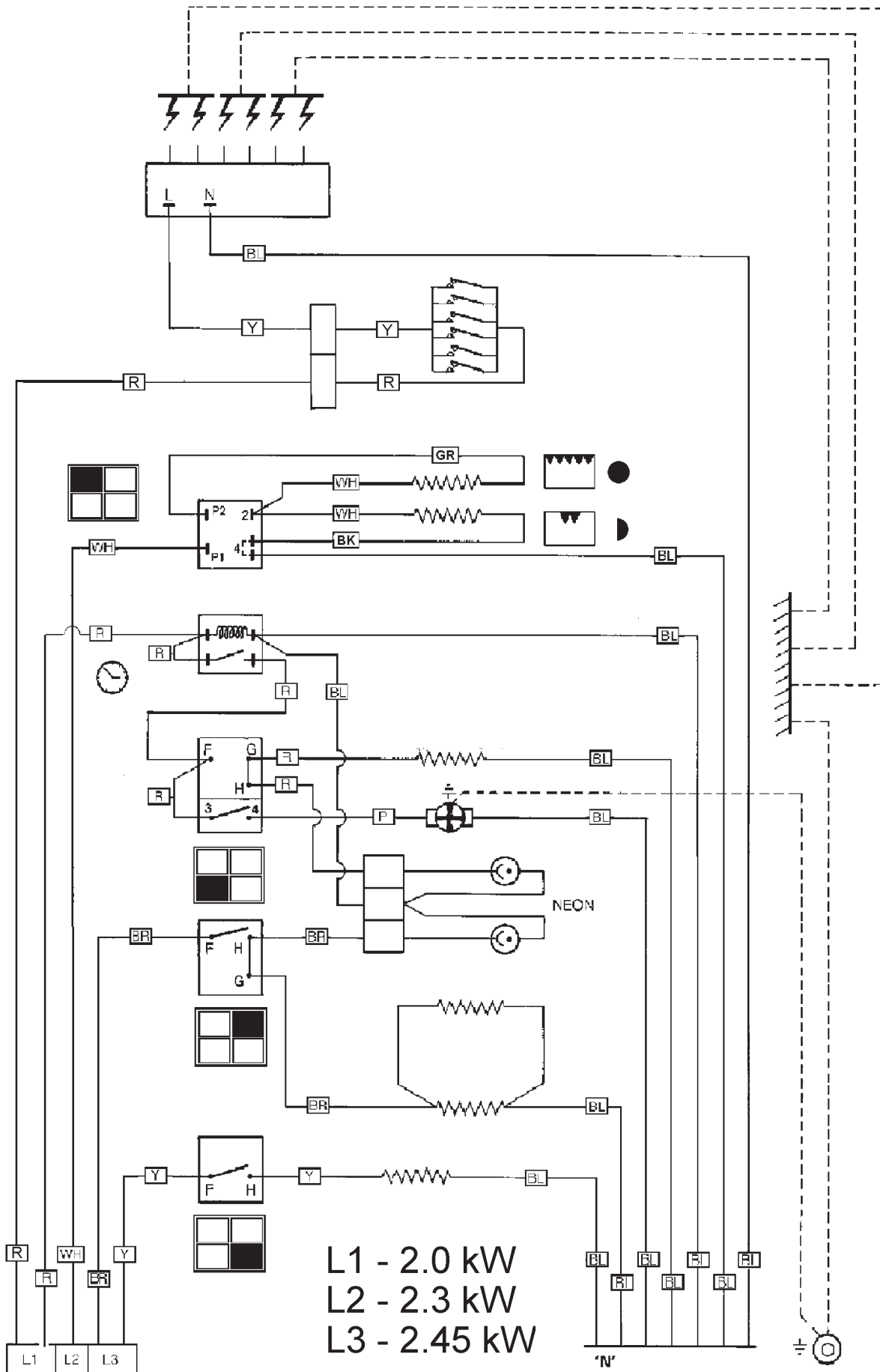

For further advice or information please contact
your local distributor/stockist

With AGA-Rangemaster's policy of continuous
product improvement, the Company reserves the
right to change specifications and make
modifications to the appliance described at any
time.



Manufactured by
AGA-Rangemaster
Station Road
Ketley Telford
Shropshire TF1 5AQ
England

www.agaliving.com
www.agacookshop.co.uk