

Fig. 1

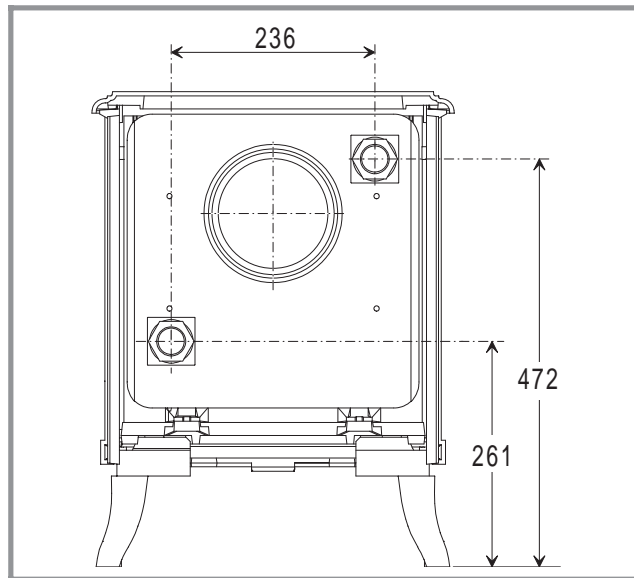

Fig. 2

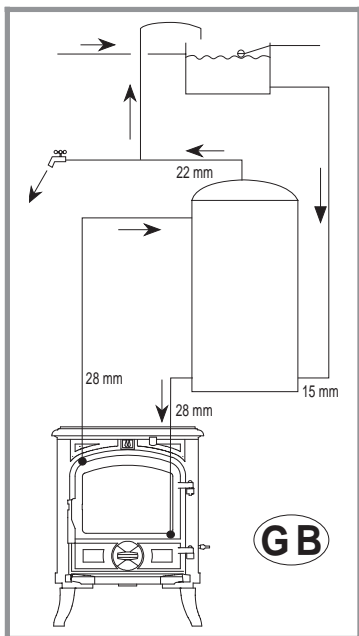

Fig. 3

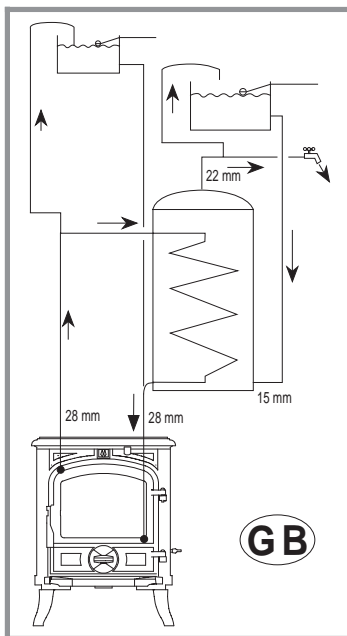

Fig. 4

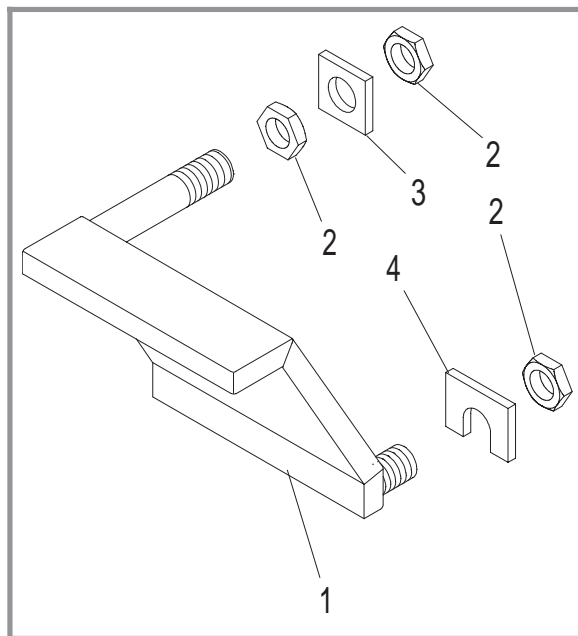

Fig. 5

Français

Fig. 1 - Montage du corps de chauffe

Fig. 2 - Dimensions en mm

Fig. 3 et Fig. 4 - Exemple d'installation hydraulique

Installations préconisées pour la Grande Bretagne.

Fig. 5 - Pièces détachées

N°	Codes	Désignation	Qty
1	911136	Corps de chauffe	01
2	122703	Contre-écrou 1"	03
3	427005	Joint	01
4	427006	Joint	01

English

Fig. 1 - Water jacket installation

Fig. 2 - Dimensions in mm

Fig. 3 and Fig. 4 - Installing the appliance

Fig. 3 : Use with direct hot water cylinder

Fig. 4 : Use with indirect hot water cylinder

Fig. 5 - Spare parts

N°	Parts N°	Description	Qty
1	911136	Water jacket	01
2	122703	Nut 1"	03
3	427005	Gasket	01
4	427006	Gasket	01