

 **bekas**
HEATING TECHNOLOGY

O.S.B. 16.Cad. No:63 38070
Melikgazi - Kayseri / TURKEY
TEL +90 352 321 18 36
FAX +90 352 321 18 39

www.bekas.com.tr
info@bekas.com.tr

www.arkoda.com

2017

 **bekas**
HEATING TECHNOLOGY



ООО "БЕКАШ"
BEKAŞ
ТЕХНОЛОГИИ ОБОГРЕВА
O NAS

Компания "BEKAŞ ISI SANAYI ve TICARET LTD. ŞTİ." основана в 1976 году в промышленном центре г.Кайсери с производственной площадью 15.000 м², начала с литья чугунных изделий. Начиная с 1995 года БЕКАШ начал производство твердотопливных отопительных печей. В данный момент производственная мощность фирмы - 80.000 печей в год, на 2017 год запланировано увеличение производства до 100.000 отопительных печей в год. В данный момент БЕКАШ работает в трёх направлениях:

- Литьё чугунных изделий,
- Эмалирование и
- Производство твердотопливных отопительных печей.

БЕКАШ, постоянно следит за развитием технологий производства твердотопливных отопительных печей в мире, ежегодно делает технический осмотр оборудования, проверяет качество продукции и имеет соответствующие сертификаты, своевременно обновляет производственные станки и развивает производственные линии. Для повышения качества выпускаемой продукции БЕКАШ следит за всеми процессами производства, заранее планируя все этапы, сокращает время производства продукции, делая процесс производства твердотопливных отопительных печей непрерывным и более эффективным.

BEKAŞ
HEATING TECHNOLOGY
ABOUT US

As a family business in 1976 by two friends in the area of 15.000 square meters in Kayseri industrial zone established with the aim to manufacture cast iron ,solid fuel stoves in 1991 ,our factory began to manufacture . 120 experience personnel and continous self improvement ,which aims to deliver the best result by using the technology of tomorrow , R&D department ,efficiency, economy and comfort are the principle follows.Recently second surely the task of generation units the ccompany continued to grow and reached a production capacity of 80.000 per year . Today cast iron ,enamel and stove in 3 section , including seperate manufacturing facility .To achieve customer satisfaction continous to wrok with dealers and service points in all provinces . Bekas export to over the 14 countries,different models to suit the need and eco friendly products certificated in steel uses .This years celebrating 25 years . Bekas ,product variety and quality ,Turkey is the world's stove is on its way to becoming a brand .

BEKAŞ
Tecnologia di riscaldamento
RIGUARDO A NOI

La nostra azienda è stata fondata nel 1976. Kayseri zona industriale organizzata è costruita su 15.000 m². Nel 1991, la stufa ha avviato la produzione. 120 operai stanno lavorando. situato all'interno del reparto di ricerca e sviluppo, la tecnologia stessa, il principio di efficienza, comfort e comprensione. La capacità produttiva annua è di 80.000 unità. Ghisa, smalto, stufa ha tre parti principali, ale a dire reparti produttivi. La pelle è l'esportazione in più di 14 paesi. Bekas verso l'essere un marchio mondo festeggia i suoi 26 anni.

"БЕКАШ"
BEKAŞ
TEHNOLOGIJA GRIJANJA
O NAMA

Naša firma je osnovana 1976. godine u Kajseriju (Kayseri) na 15.000 m² od strane dva prijatelja koja su proizvodila lijevano željezo (gus) da bi 1991. godine počeli sa proizvodnjom peći na čvrsto gorivo. Sa 120 zaposlenih i AR-GE dijelom koji se neprestano usavršava, koji koristi naprednu tehnologiju i koji ima za cilj da dobije najbolje rezultate postavili smo principe koji se tiču visokog doprinosa, uštede i komfora. Firmu je preuzela druga generacija i sigurnim koracima svakodnevno raste tako da je dostigla proizvodnja od 80.000 peći godišnje. Danas u fabrici imamo tri proizvodne jedinice, a to su proizvodnja lijevanog željeza (gus), proizvodnja emajla i proizvodnja peći. Imamo poslovnice i servise u svim gradovima u Turskoj i cilj nam je zadovoljstvo kupaca. Bekaş svoje proizvode, koji su proizvedeni od certificiranih limova i koji su prijatelji okoline, izvozi u 14 zemalja. Bekaş, koji ove godine slavi 26. rođendan, sa svojim kvalitetom i različitim vrstama proizvoda na putu je da postane ne samo marka u Turskoj nego i u svijetu.

ЗНАЧКИ / ICONS / ICONE / IKONE

Экологичный Environment friendly Ecologico Prijatelj okoline	Вес Weight Peso Netto Težina	Теплоотдача Thermal Power Potenza Termica Snaga	Рабочее давление Operating Pressure Pressione di esercizio Radni pritisak	Печь отопительно варочная Oven Forno Peć sa pećnicom	Ø трубы Pipe Diameter Diametro Uscita Fumi Prečnik izlaza za dimnjak	Турбо Turbo Turbo Turbo	Дрова Wood Legno Drvo	Уголь Coal Carbone Ugalj
Брикет Briquette Bricchetta Briket	Огнеупорный кирпич Fire Brick Argilla refrattaria Vatrostalna opeka (samot)	Чугунный кирпич Cast Iron Brick Ghisa refrattaria Lijevano željezo (gus)	Загрузка спереди Front Loading davanti di alimentazione Ložište sprijeda	Загрузка сверху Top Loading Ložište odozgo	Выход трубы справа Chimney Out Right destra - uscita fumi Izlaz za dimnjak sa desne strane	Выход трубы слева Chimney Out Left Sinistra uscita fumi Izlaz za dimnjak sa lijeve strane	M M Tül M Dužni metar	Пеллет Pellet Pellet Pelet
Динамичная Система Бекаш Bekaş Dynamic System BDS Dinamički sistem Bekaş	Фан Fan ventilatore Ventilator	Герметичный Hermetic ermetico Hermetički	Гидро Hydro hydro Hidro	ЭКО	Автоматика стекла Automatic Glass Cleaning Pulizia vetro Automatsko čišćenje stakla	Всесезонный All Season tutte le stagioni Za sva godišnja doba		
На пульте управления Remote Control telecomando Kontrola iz daljine	Lan Lan Lan	Bluetooth Bluetooth Bluetooth Bluetooth	Сенсорный Touch Screen toccare schermo Na dodir	Беззвучный Silent silenzioso Tih	Закрытая система Closed System sistema vicino Zatvoreni sistem	Воздушное отопление Air Flow Stufe canalizzate Grijanje zračenjem		

BlmSchV
1 - 2



Turkey
Discover the potential



Наши каминны оснащены огнеупорным стеклом марки **SCHOTT ROBAX®**.
We have to use **SCHOTT ROBAX®** brand our Fireplaces models.

Nei modelli camino, è usato marchio **SCHOTT ROBAX®** vetro.
Staklo na kaminima je marke **SCHOTT ROBAX®**.

Содержимое
Пеллетные печи
Кирпичные печи
Печи с водяным отоплением
Печи со съёмной топкой
Аксессуары

Index
Pellet Stoves
Brick Stoves
Hydro Stoves
Bucket Stoves
Accessories

Indice
Stufe a Pellet
Stufe a Legna
Termostufe
Stufe Convezione Naturale
Accessori

Sadržaj
Peći na pelet
Peći sa opekom
Peći za toplu vodu
Peći sa kantom
Aksesoari

**26th
YEAR**

**Пеллетные печи
Pellet Stoves
Stufe a pellet
Peći na pelet**



1110
HydroGreen 100

Пеллетные печи / Pellet Stoves
Stufe a pellet / Peći na pelet



1120
HydroGreen 100

Пеллетные печи / Pellet Stoves
Stufe a pellet / Peći na pelet

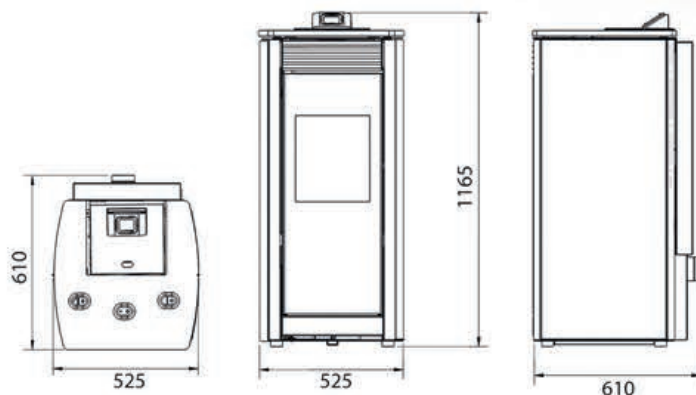
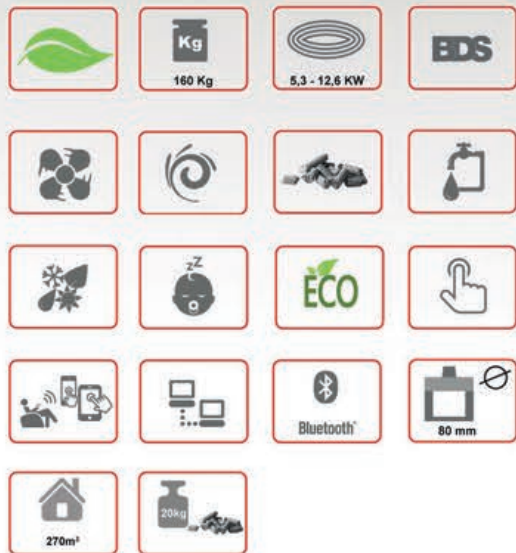

* Дополнительные функции
- На пульте управления
- Bluetooth
- Герметичный
- LAN
- Динамичная Система Бекаш

* Optional Features
- Remote Control
- Bluetooth
- Hermetic
- LAN
- BDS

* Funzioni aggiuntive
- Telecomando
- Bluetooth
- Ermetico
- LAN
- BDS

* Dodatne funkcije
- Kontrola iz daljine
- Bluetooth
- Hermetički
- LAN
- Dinamički sistem Bekas

Теплоотдача 94%
Использование биотоплива
Потребление энергии A+ (110 ватт)
Возможность подачи горячей воды для обогрева всех помещений
Вместительность до 20 кг топлива
Цифровой LCD дисплей
Пульт дистанционного управления
7 точек контроля и сенсоров для оптимальной синхронизации
Модуль Ethernet для удалённого управления
Программирование на день или неделю для повышенной комфортности
Технология обогрева Бекаш с полной модуляцией пламени
Широкое окно для наблюдения за зппламенем
Блок автоматического зажигания, цифровое управление
Система настройки постоянной температуры помещения
Датчики контроля термостата внутри и снаружи печи
Самоочищающееся 800°C жаропрочное керамическое стекло
Специально разработанная обтекаемая хромированная передняя решётка
Зольник большого объёма (сменный)
Фан с мощностью 400 м³/ч и настройкой разных скоростей
Чугунная топка

94% high efficiency
Used biofuel renewable energy
A+ energy consumption (110 watt)
Central heating technology
Storage capacity 20 kg
Digital LCD display
Remote Control Unit
Optimum synchronization with 7 point sensor
Remote desktop connection from the internet
Daily, Weekly timer
Full flame modulation with BDS technology
Large flame viewing window
Automatic ignition unit
Automatic room thermostat
Automatic cleaning, 800 °C resistant ceramic glass
Special custom designed chrome front panel
Cast Iron combustion chamber
Fan system that can be adjusted at different speeds 400m³/h

Alto Rendimento % 94
Utilizza pellet
Potenza elettrica in esercizio
Riscaldamento centralizzato
Capacità serbatoio pellet 20kg
Pannello digitale LCD;
Telecomando
Massima sicurezza utilizzando multisensore
Ethernet module
Fasce orarie di funzionamento programmabili su base giornaliera e Settimanale
Modulazione completa con il sistema BDS
Portina estetica in vetro a specchio che, a focolare acceso, permette la visione della fiamma
Sonda ambiente per la gestione della temperatura programmata
Vetro ceramico resistente fino a 800 °C
Nuovo design della griglia anteriore cromata
Ampio cassetto di raccolta cenere
Ventilatore tangenziale da 400 m3/h, regolabile su più velocità
Braciare e schienale del focolare in ghisa ad alto spessore

Stepen iskorištenja 94%
Bio gorivo koje se obnavlja
Potrošnja energije A+ (110W)
Mogućnost grijanja svih prostorija sa centralnim grijanjem
Kapacitet rezervoara za pelet 20 kg
Digitalni LCD ekran
Kontrola iz daljine
Optimalna sinkronizacija pomoću 7 kontrolnih tačaka i senzora
Ethernet Modul
Veliki komfor sa dnevnim i sedmičnim programiranjem rada peći
Modulacija punog plamena sa Bekaš tehnologijom
Veliko staklo i vidljiv plamen
Automatski zapaljiva jedinica, digitalna kontrola
Mogućnost podešavanja fiksne temperature sobe
Kontrola termostatom na peći i izvan
Samočisteće keramičko staklo otporno na 800°C
Poseban dizajn prednjih aerodinamičkih rešetki
Veliki prostor za pepeo (može se mijenjati)
Sistem ventilatora kapaciteta 400m3/h sa mogućnošću kontrole brzine
Prostor za loženje je od lijevanog željeza (gus)





NEW

Теплоотдача 92%
Использование биотоплива
Потребление энергии A+ (110 ватт)
Вместительность до 20 кг топлива
Цифровой LCD дисплей
Пульт дистанционного управления
6 точек контроля и сенсоров для оптимальной синхронизации
Модуль Ethernet для удалённого управления
Программирование на день или неделю для повышенной комфортности
Технология обогрева BeKaš с полной модуляцией пламени
Широкое окно для наблюдения за зтпламенем
Блок автоматического зажигания, цифровое управление
Система настройки постоянной температуры помещения
Датчики контроля термостата внутри и снаружи печи
Самоочищающееся 800°C жаропрочное керамическое стекло
Специально разработанная обтекаемая хромированная передняя решётка
Зольник большого объёма (сменный)
Фан с мощностью 400 м³/ч и настройкой разных скоростей
Чугунная топка

Alto Rendimento % 92
Utilizza pellet
Potenza elettrica in esercizio
Capacità serbatoio pellet 20kg
Pannello digitale LCD:
Telecomando
Massima sicurezza utilizzando multisensore
Ethernet module
Fasce orarie di funzionamento programmabili su base giornaliera e Settimanale
Modulazione completa con il sistema BDS
Portina estetica in vetro a specchio che, a focolare acceso, permette la visione della fiamma
Sonda ambiente per la gestione della temperatura programmata
Vetro ceramico resistente fino a 800 °C
Nuovo design della griglia anteriore cromata
Ampio cassetto di raccolta cenere
Ventilatore tangenziale da 400 m3/h, regolabile su più velocità
Braciare e schienale del focolare in ghisa ad alto spessore

%92 high efficiency
Used biofuel renewable energy
A+ energy consumption (110 watt)
Storage capacity 20 kg
Digital LCD display
Remote Control Unit
Optimum synchronization with 6 point sensor
Remote desktop connection from the internet
Daily, Weekly timer
Full flame modulation with BDS technology
Large flame viewing window
Automatic ignition unit
Automatic room thermostat
Special custom designed chrome front panel
Automatic cleaning, 800 °C resistant ceramic glass
Cast Iron combustion chamber
Fan system that can be adjusted at different speeds 400m³/h

Stepen iskoristenja 92%
Bio gorivo koje se obnavlja
potrošnja energije A+ (110 W)
Kapacitet rezervoara za pelet 20 kg
Digitalni LCD ekran
Kontrola iz daljine
Optimalna sinkronizacija pomoću 6 kontrolnih tačaka i senzora
Ethernet Modul
Veliki komfor sa dnevnim i sedmičnim programiranjem rada peći
Modulacija punog plamena sa BeKaš tehnologijom
Veliko staklo i vidljiv plamen
Automatski zapaljiva jedinica, digitalna kontrola
Mogućnost podešavanja fiksne temperature sobe
Kontrola termostatom na peći i izvan
Samočisteće keramičko staklo otporno na 800 °C
Poseban dizajn prednjih aerodinamičkih rešetki
Veliki prostor za pepeo (može se mijenjati)
Sistem ventilatora kapaciteta 400m³/h sa mogućnošću kontrole brzine
Prostor za loženje je od lijevanog željeza (gus)

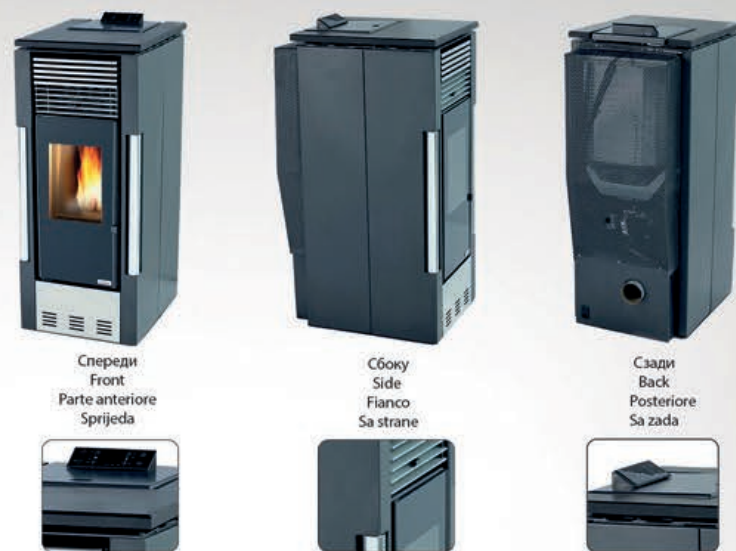
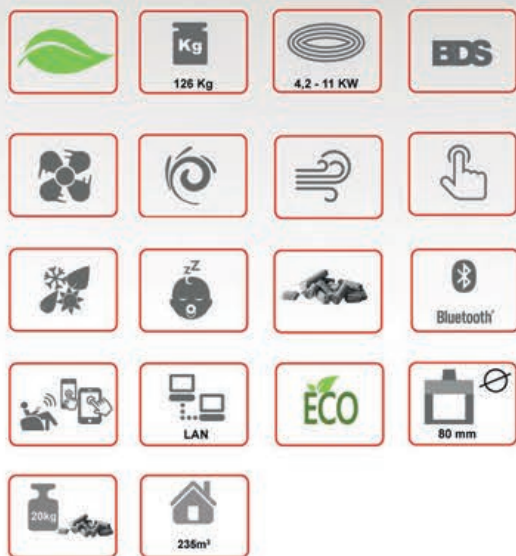

* Дополнительные функции
- На пульте управления
- Bluetooth
- Герметичный
- LAN
- Динамичная Система Бекаш

* Optional Features
- Remote Control
- Bluetooth
- Hermetic
- LAN
- BDS

* Funzioni aggiuntive
- Telecomando
- Bluetooth
- Ermetico
- LAN
- BDS

* Dodatne funkcije
- Kontrola iz daljine
- Bluetooth
- Hermetički
- LAN
- Dinamički sistem Bekas

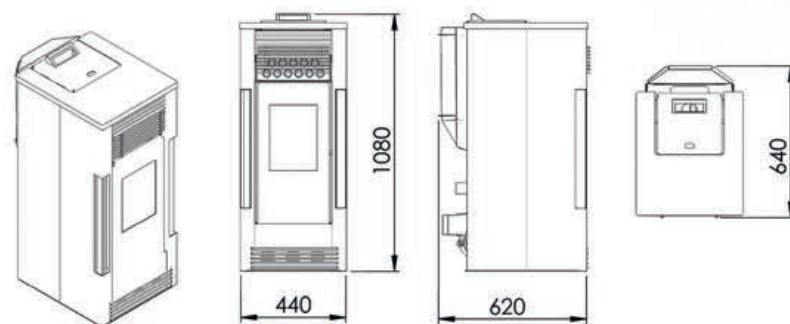

**26th
YEAR**

**Кирпичные печи
Brick Stoves
Stufe a Legna
Peći sa opekom**



2110
POWER GREEN 100



2210
POWER GREEN 200



2310
POWER GREEN 300

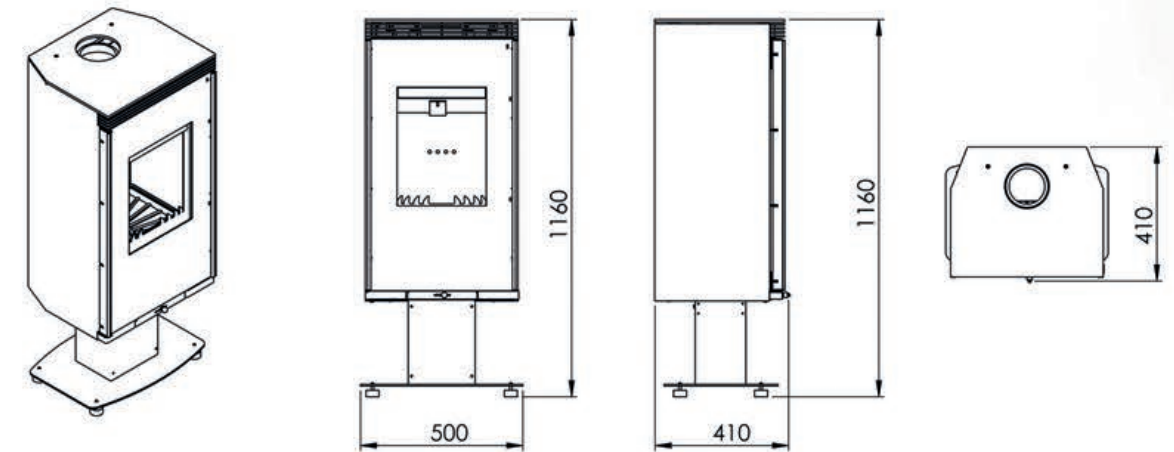
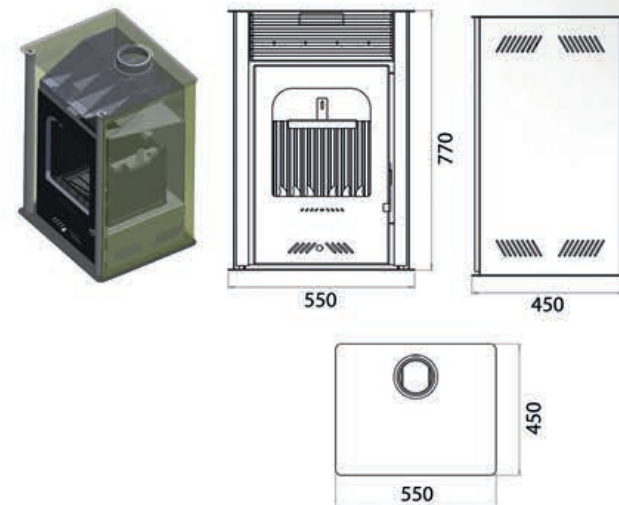
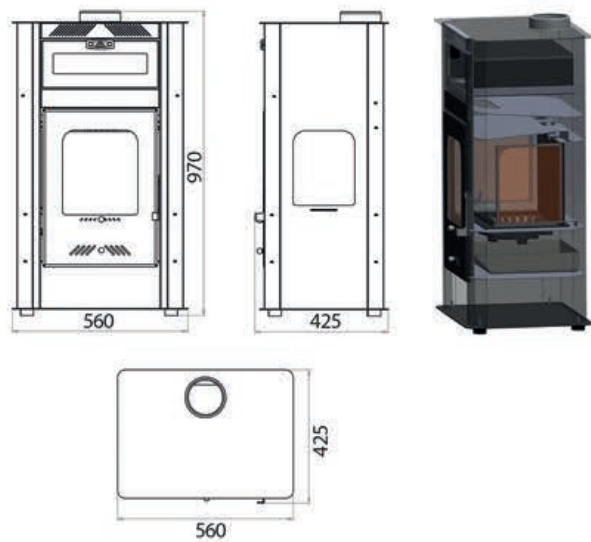

806
MEDIUM LUX FIREPLACE



807
MEDIUM LUX FIREPLACE



904
SALOON LUX FIREPLACE



905
SALOON LUX FIREPLACE

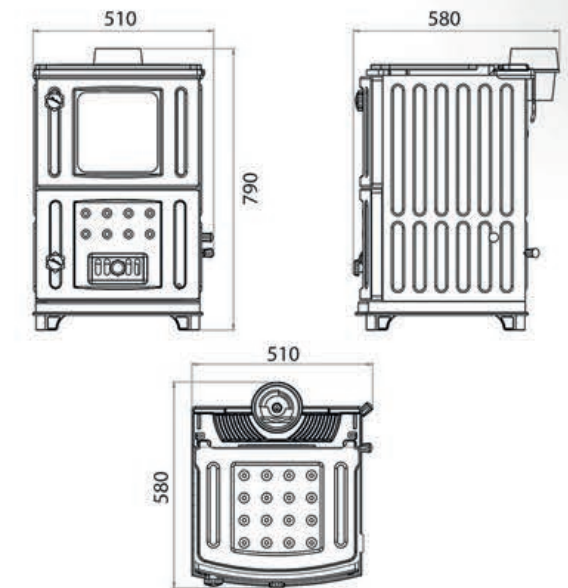
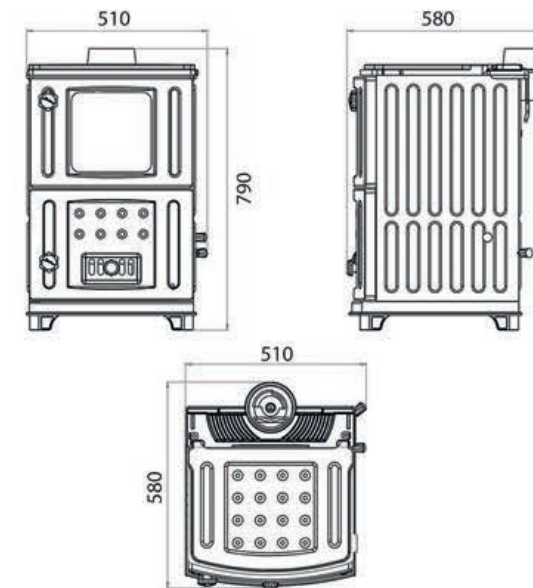
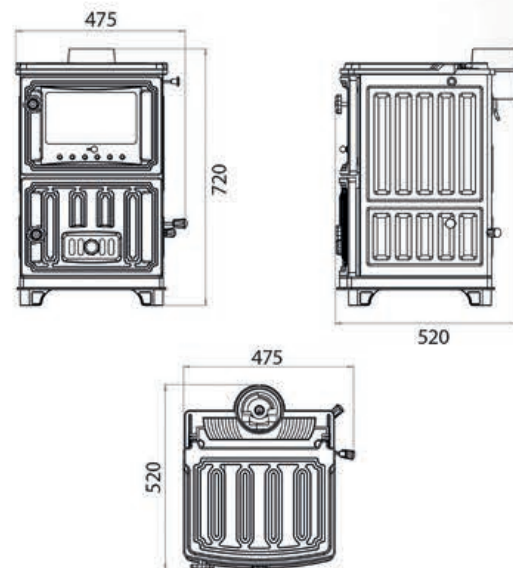
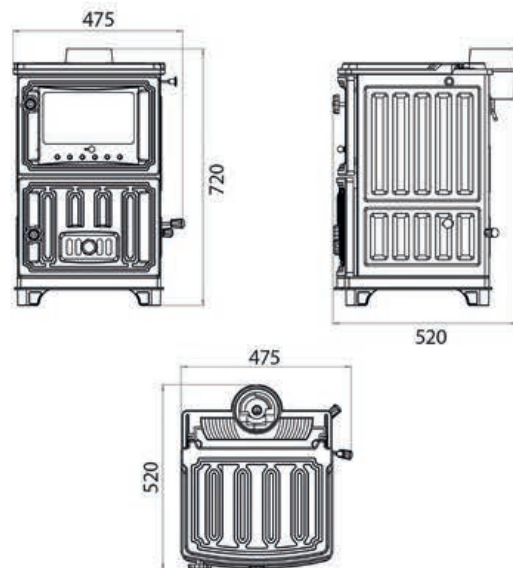

320
FOUR STAR SINGLE OVEN FIREPLACE



320 S
FOUR STAR SINGLE OVEN FIREPLACE



610
FIVE STAR SINGLE OVEN



704
SALOON DOUBLE OVEN

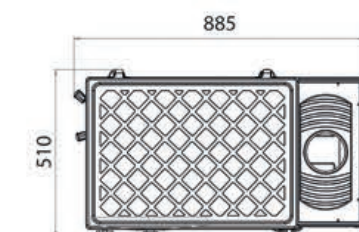
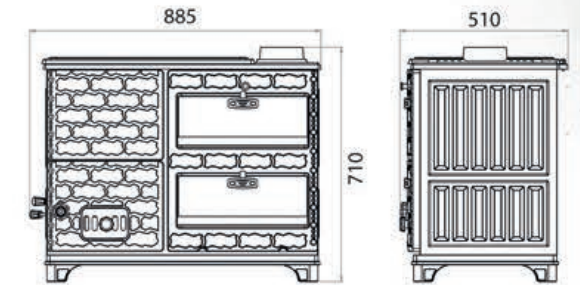
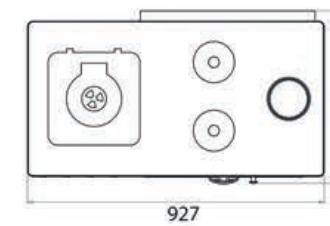
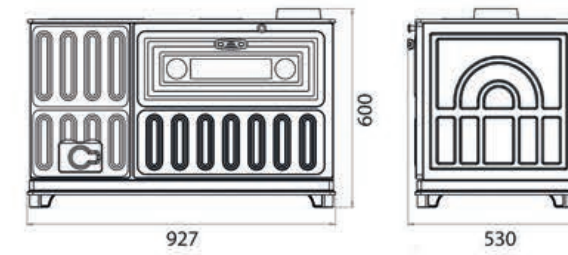
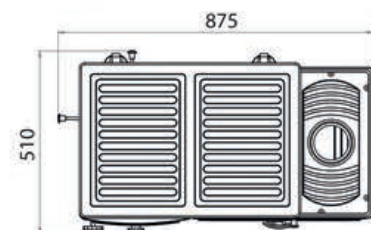
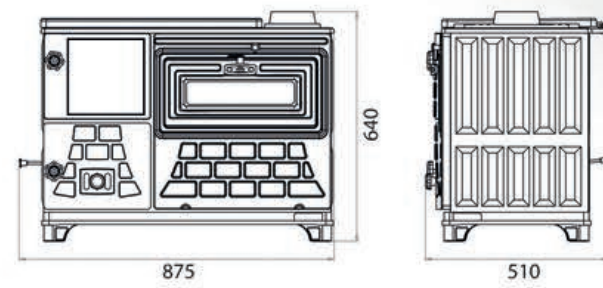
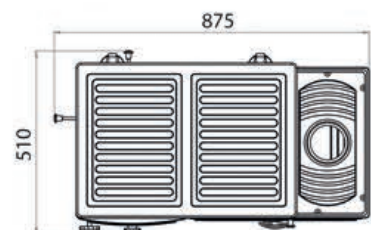
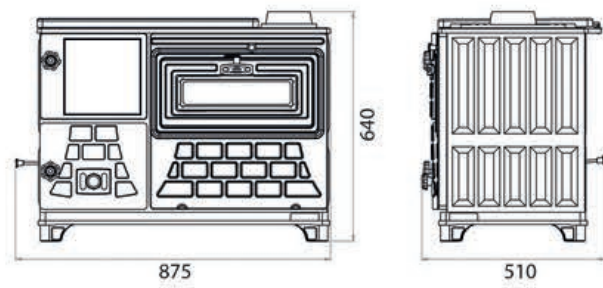

671
BALKAN STOVE



675
BALKAN STOVE



102
31" CIRCLE STOVE



138
36" CIRCLE STOVE



677
BALKAN STOVE

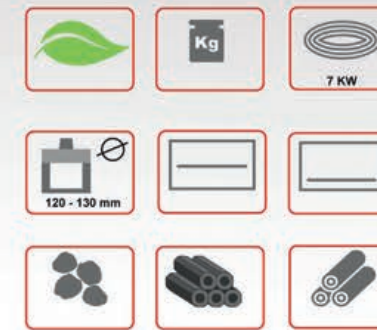
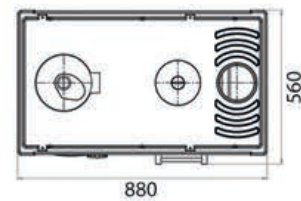
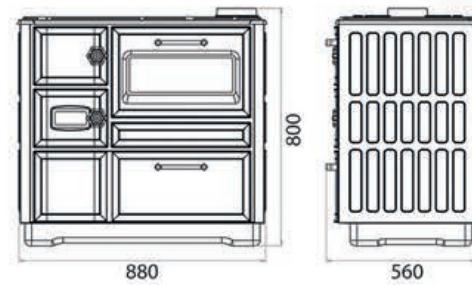

Доступны литые ножки
Cast Iron Legs Available
Gamba in ghisa
Nogare od lijevanog željeza (gus)

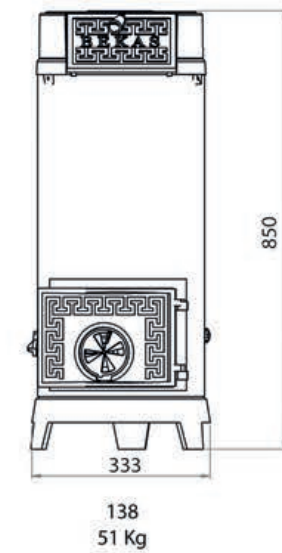
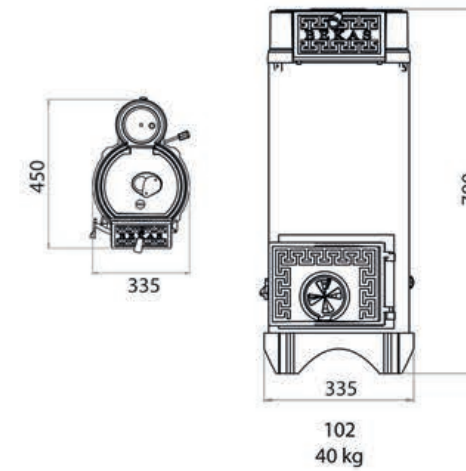

**26th
YEAR**

**Печи с водяным отоплением
Hydro Stoves
Termostufe
Peći za toplu vodu**



7003
SALOON DOUBLE
OVEN HYDRO



8002
MEDIUM HYDRO



9002
SALOON HYDRO



Компактная закрытая система / Compact closed system
sistema compatto / Kompaktni zatvoreni sistem



Открытая и закрытая система доступна во всех наших моделях печей с центральным отоплением
Hydro models have optional close system or open system
Kod svih peći sa centralnim grijanjem imamo otvoreni i zatvoreni sistem



Открытая и закрытая система доступна во всех наших моделях печей с центральным отоплением
Hydro models have optional close system or open system
Kod svih peći sa centralnim grijanjem imamo otvoreni i zatvoreni sistem



Расширительный бак
Imbisat deposu
Vaso di espansione
Ekspanziona posuda

Открытая система / Open system
sistemi aperti / Otvoreni sistem

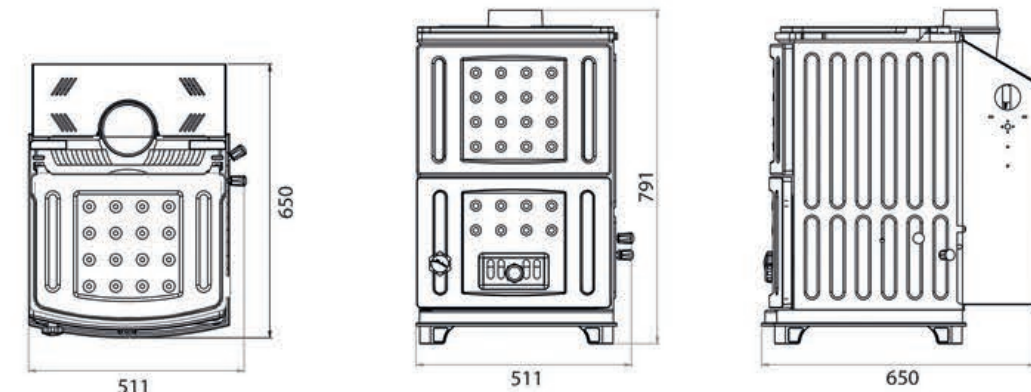
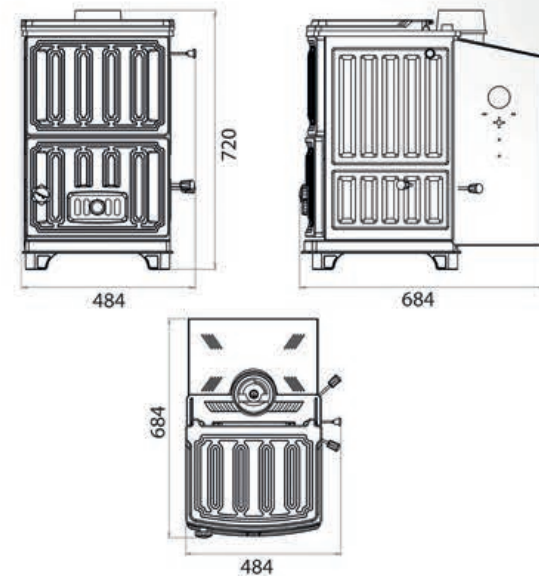
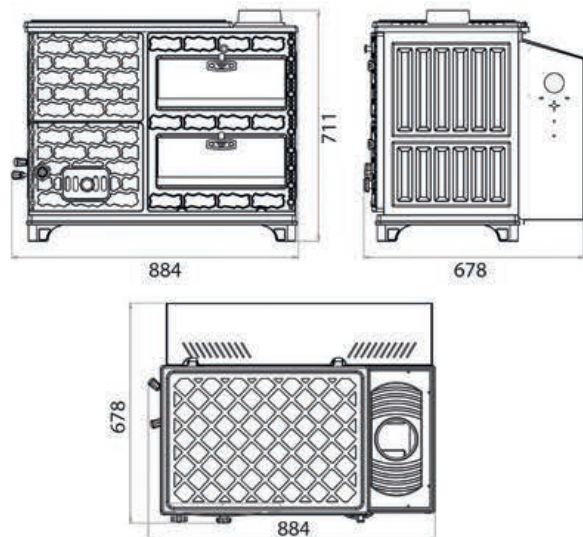

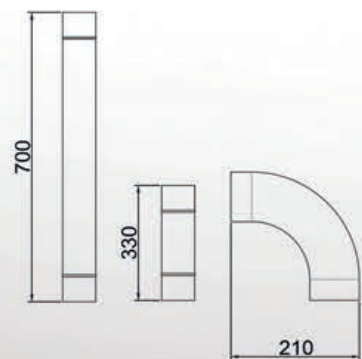

957



WEIGHT : 13 KG / THICKNESS : 10 MM
 BEC : 13 КГ / ТОЛЩИНА : 10 MM
 PESO : 13 KG / SPESSORE : 10 MM
 TEŽINA : 13 KG / DEBLJINA : 10 MM



NEW

960

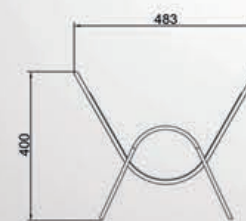

WEIGHT : 2,5 KG
 BEC : 2,5 КГ
 PESO : 2,5 KG
 TEŽINA : 2,5 KG



NEW

959

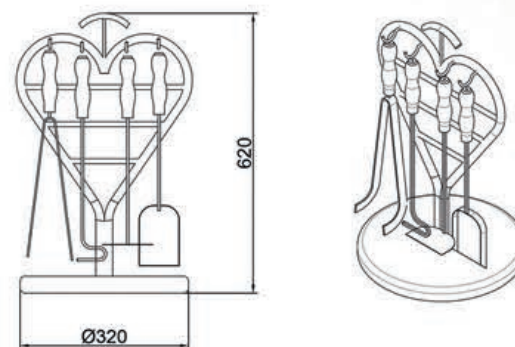

WEIGHT : 2,7 KG
 BEC : 2,7 КГ
 PESO : 2,7 KG
 TEŽINA : 2,7 KG

958

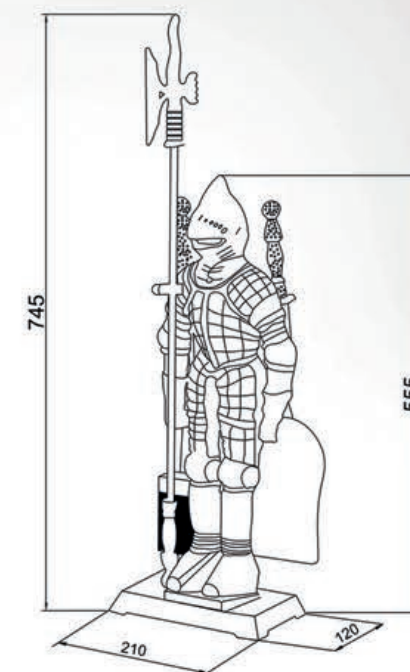

WEIGHT : 7,4 KG
 BEC : 7,4 КГ
 PESO : 7,4 KG
 TEŽINA : 7,4 KG



Информация, содержащаяся в данном документе, была тщательно проверена и считается достоверной; однако, компания не несет никакой ответственности за ошибки набора и корректуры, типографские ошибки или опечатки, разницу в цвете. В целях совершенствования продукции технические характеристики могут быть изменены без предварительного уведомления.
Our company is not responsible for typographical errors in this catalog.
Our company is not responsible for the color differences caused by the printing.
Our company reserves the right to make changes on the products in our catalogue without prior notice.
Contenute in questo catalogo, la nostra società non è responsabile per errori tipografici.
La nostra società non è responsabile per le differenze di colore causate dalla tipografia.
La nostra società si riserva il diritto di apportare modifiche senza preavviso sulla quantità di prodotti presenti nel catalogo
Naša firma nije odgovorna za štamparske greške.
Naša firma nije odgovorna za razlike u bojama proizvoda i slika nastalim štamparskom greškom