

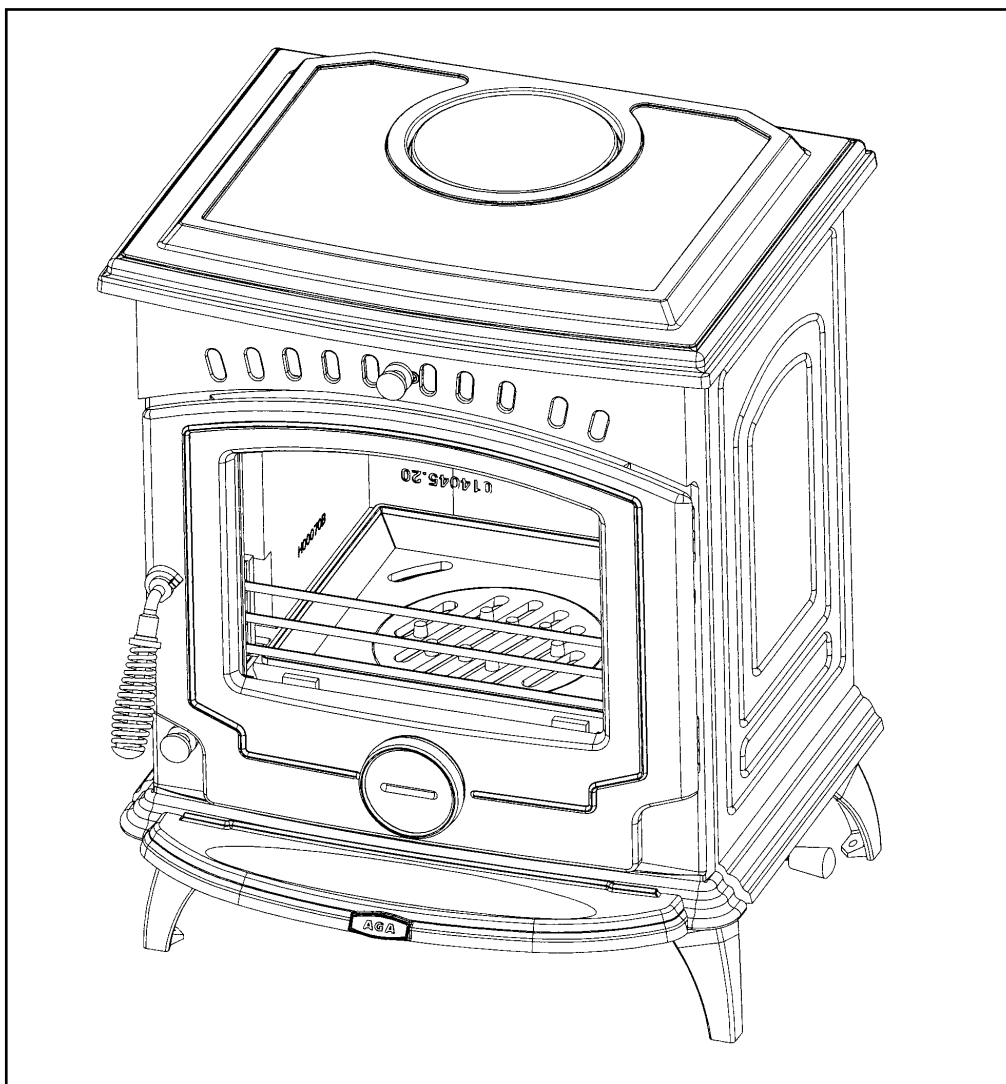

MUCH WENLOCK NON- BOILER SOLID FUEL STOVE



WARNING: This appliance is hot while in operation and retains its heat for a long period of time after use. Children, aged or infirm persons should be supervised at all times and should not be allowed to touch the hot working surfaces while in use or until the appliance has thoroughly cooled.

INSTALLATION AND OPERATING INSTRUCTIONS

TABLE OF CONTENTS

	PAGE NO.
1. General	3
2. Pre-Installation Assembly	3
3. Flues	3
4. Chimney	3
5. Ventilation & Combustion Air Requirements	4
6. Flue Pipes	4
7. Top Flue Exit	4
8. Rear Flue Exit	5
9. Location	5
10. Installation Clearances	5
11. Floor Protection	5
12. Specification	6
13. Lighting	7
14. Important Notes	8
15. Operating Instructions	9
16. Primary Air Settings	9
17. Recommended Fuels	9
18. Air Wash Settings	9
19. Tertiary Air/System Control	9
20. Operation	10
21. Overnight Burning	10
22. Re-Fuelling	10
23. De-Ashing	10
24. Disposal of Ashes	10
25. To Clean Chimney Outlet	10
26. Fire Safety	11
27. Vitreous Enamel Cleaning	11
28. Glass Cleaning	11
29. Glass Replacement	11
30. Exploded View	12



MUCH WENLOCK SOLID FUEL NON BOILER STOVE INSTALLATION & OPERATING INSTRUCTIONS

GENERAL

When installing, operating and maintaining your stove respect basic standards of fire safety. Read these instructions carefully before commencing the installation. Failure to do so may result in damage to persons and property. Consult your local Municipal office and your insurance representative to determine what regulations are in force. Save these instructions for future reference.

The installation must be completed in accordance with current National and European Standards and Local Codes. It should be noted that the requirements and these publications may be superseded during the life of this manual.

PRE INSTALLATION ASSEMBLY

1. After removing the stove from its pack, open the front door and remove the contents.
2. Fit the front door handle.
3. Remove the stove from the wooden pallet.
4. Fit the front ash tray by slotting into place on the front and secure it using the screws provided.

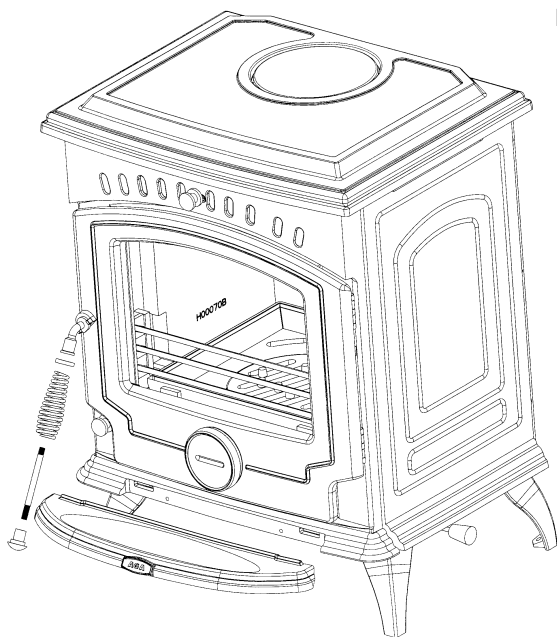

Fig. 1

FLUES

Flues should be vertical wherever possible and where a bend is necessary, it should not make an angle of more than 45° with the vertical. Horizontal flue runs should be avoided except in the case of a back outlet from the appliance, when the length of the horizontal section should not exceed 150mm.

In order to minimise flue resistance and to make sweeping easier it is recommended to use 2 x 45° bends rather than a 90° bend.

The flue termination point must be located to minimise any wind effects. Wind effects of suction, pressure zones and turbulence can be created by the roof and adjacent objects. Wind effects can also be created by natural land contours.

To minimise the wind effects, the flue termination point should be located a minimum of 600mm from the roof measured vertically and 2300mm measured horizontally. Where this termination point does not suffice it may be necessary to extend the flue pipe so that the termination point is above the apex.

Fig 2

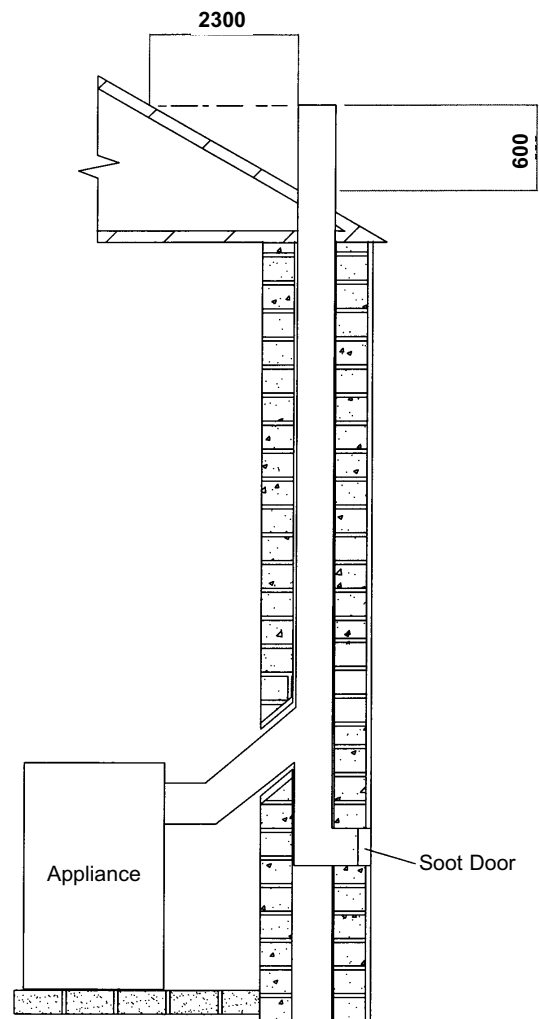

CHIMNEY

This stove is a radiant room heater and must be connected to a chimney of the proper size and type. The chimney must have a cross-sectional area of at least 181cm² or a diameter of at least 150mm. It is best to connect to a chimney of the same size, as connection to a larger size may result in a somewhat less draught.

This appliance is not suitable for installation in a shared flue system.

The appliance requires minimum chimney height of 4.5 metres from floor on which stove is installed. An

existing masonry chimney should be sound and if necessary inspected and repaired by a competent mason. It may be necessary to line the chimney using a suitable stainless steel flue liner. The stove must be connected to a chimney with a minimum continuous draught of 12 Pascal's to obtain nominal output. Poor draught conditions will result in poor stove performance. Allowing for an access into the chimney at the lower end will facilitate cleaning. Chimneys for use with solid fuel appliances should be capable of withstanding a temperature of 1100°C without any structural change which would impair the stability or performance of the chimney.

VENTILATION & COMBUSTION AIR REQUIREMENTS

This appliance is rated at less than 6kW. It is imperative that there is sufficient air supply to the stove in order to support correct combustion. The air supply to this appliance must comply with B.S. 8303: Part 1 and current Building Regulations. The minimum effective air requirement for this appliance is 5.5 cm². If a draught stabiliser is used then this increases to 23.5 cm². When calculating combustion air requirement for this appliance use the following equation: a total free area of at least 550mm² per kW of rated output above 5kW shall be provided.

If same or adjacent room, it will be necessary to calculate additional air supply. All materials used in the manufacture of air vents should be such that the vent is dimensionally stable and corrosion resistant.

The effective free area of any vent should be ascertained before installation. The effect of any screen should be allowed for when determining the effective free area of any vent.

Air vents direct to the outside of the building should be located so that any air current produced will not pass through normally occupied areas of the room. An air vent outside the building should not be located less than the dimensions specified within the Building Regulations from any part of any flue terminal. These air vents must also be fire proofed as per Building Regulations.

Air vents traversing cavity walls should include a continuous duct across the cavity. The duct should be installed in such a manner as not to impair the weather resistance of the cavity. Joints between air vents and outside walls should be sealed to prevent the ingress of moisture. Existing air vents should be of the correct size and unobstructed for the appliance in use. If there is an air extraction fan or other air using appliance fitted in the room or adjacent rooms where this appliance is fitted, additional air vents will be required to alleviate the possibility of spillage of products of combustion from the appliance/flue while the fan is in operation. Where such an installation exists, a test for spillage should be made with the fan or fans and other appliances

using air in operation at full rate, (i.e. extraction fans, tumble dryers) with all external doors and windows closed. If spillage occurs following the above operation, an additional air vent of sufficient size to prevent this occurrence should be installed.

FLUE PIPES

A flue pipe should only be used to connect an appliance to a chimney and should not pass through any roof space. Flue pipes may be of any of the following materials:

- (a) Cast iron as described in BS 41: 1973 (1981), or
- (b) Stainless steel with a wall thickness of at least 1mm and as described in BS EN 10095:1999 Specification for stainless and heat resisting steel plate, sheet and strip, for Grade 316 S11, 316 S13, 316 S16, 316 S31, 316 S33, or the equivalent Euronorm 88-71 designation, or
- (c) Vitreous enamelled steel complying with BS 6999: 1989.

Flue pipes with spigot and socket joints should be fitted with the socket upper most. Clearance to combustibles must be adhered to when fitting the flue pipe. The flue gas mass flow is 4.56 g/s mineral fuel and 4.11 g/s wood logs. The mean flue gas temperature directly downstream of the spigot at nominal heat output is 275 °C. The appliance is suitable for continuous operation on solid mineral fuel and intermittent operation on wood logs.

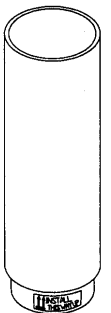

TOP FLUE EXIT

For top outlet configuration remove the hob from the top of the stove, turn the hob upside down and place it on the floor, taking care not to damage it. Remove the hob blanking plate by unscrewing the two screws from underneath the hob. Next remove the flue blanking plate from the top of the stove by unscrewing the two screws, connect this blanking plate to the rear flue outlet at the back of the stove. Replace the hob in the correct position. Connect the connector pipe (not supplied) into the top flue outlet socket at the top of the stove and cement into place using approved fire cement ensuring that no cement blocks the flue passageway.

Fig3

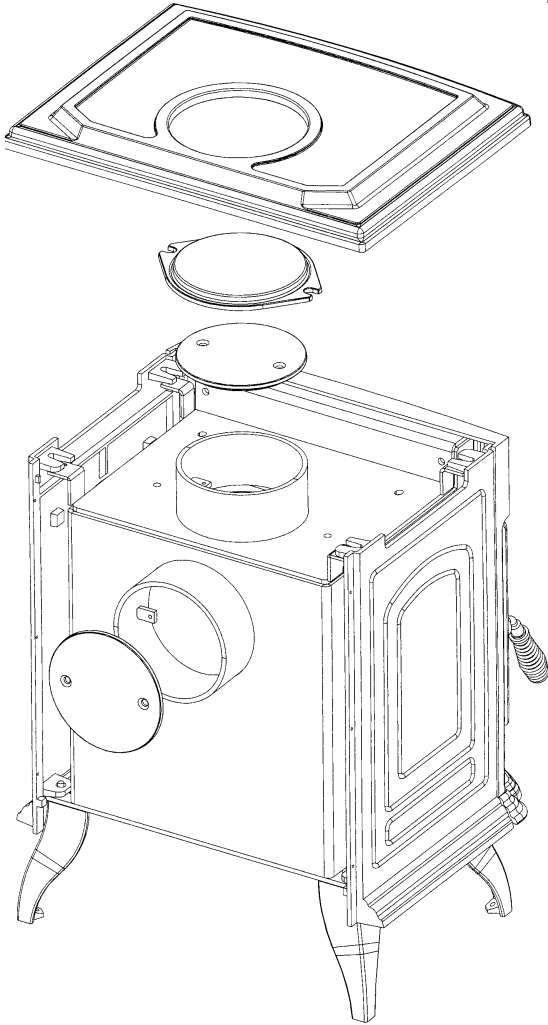

REAR FLUE EXIT

For rear flue outlet configuration push in flue connector pipe (not supplied) into flue outlet socket at the rear of the stove and cement into place using approved fire cement ensuring that no cement blocks the flue passageway.

Fig. 4

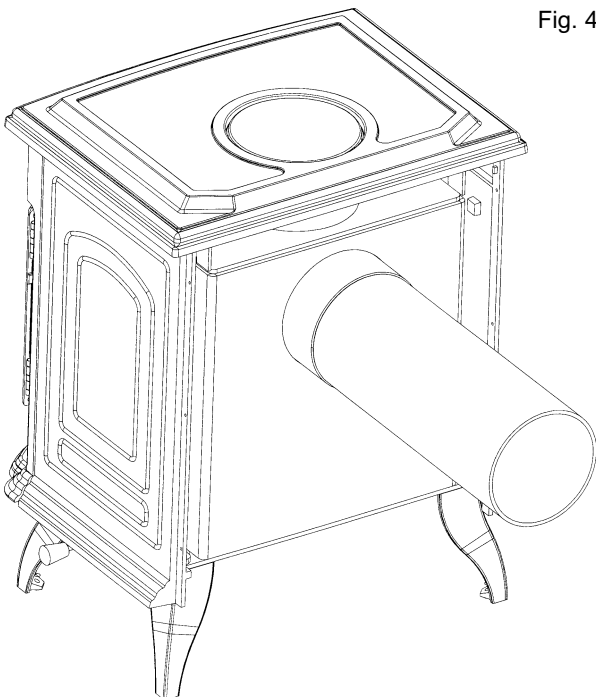

LOCATION

There are several conditions to be considered in selecting a location for your stove.

- Position in the area to be heated, central locations are usually best. If situated in an alcove, site as far forward as possible to provide more heat to the room. For non-combustible surfaces, allow a minimum air gap to the rear, sides and top of 100mm for air to flow around the appliance.
- Allowances for proper clearances to combustibles.

INSTALLATION CLEARANCES

Clearance to combustible materials

- From the front - 900mm
- From the sides - 600mm
- From the back - 700mm
- From the flue pipe - 600mm

The connector may pass through walls or partitions constructed of combustible materials provided the connector is either listed for wall pass-through or is routed through a device listed for a wall pass-through and is installed in accordance with the conditions of the listing. Any unexposed metal that is used as part of a wall pass-through system is exposed to flue gases shall be constructed of stainless steel or other equivalent material that will resist corrosion, softening, or cracking from flue gas at temperatures up to 982°C.

FLOOR PROTECTION

It is recommended that this appliance is installed on a solid, level non-combustible hearth conforming to current Building Regulations.

SPECIFICATION

Fig5

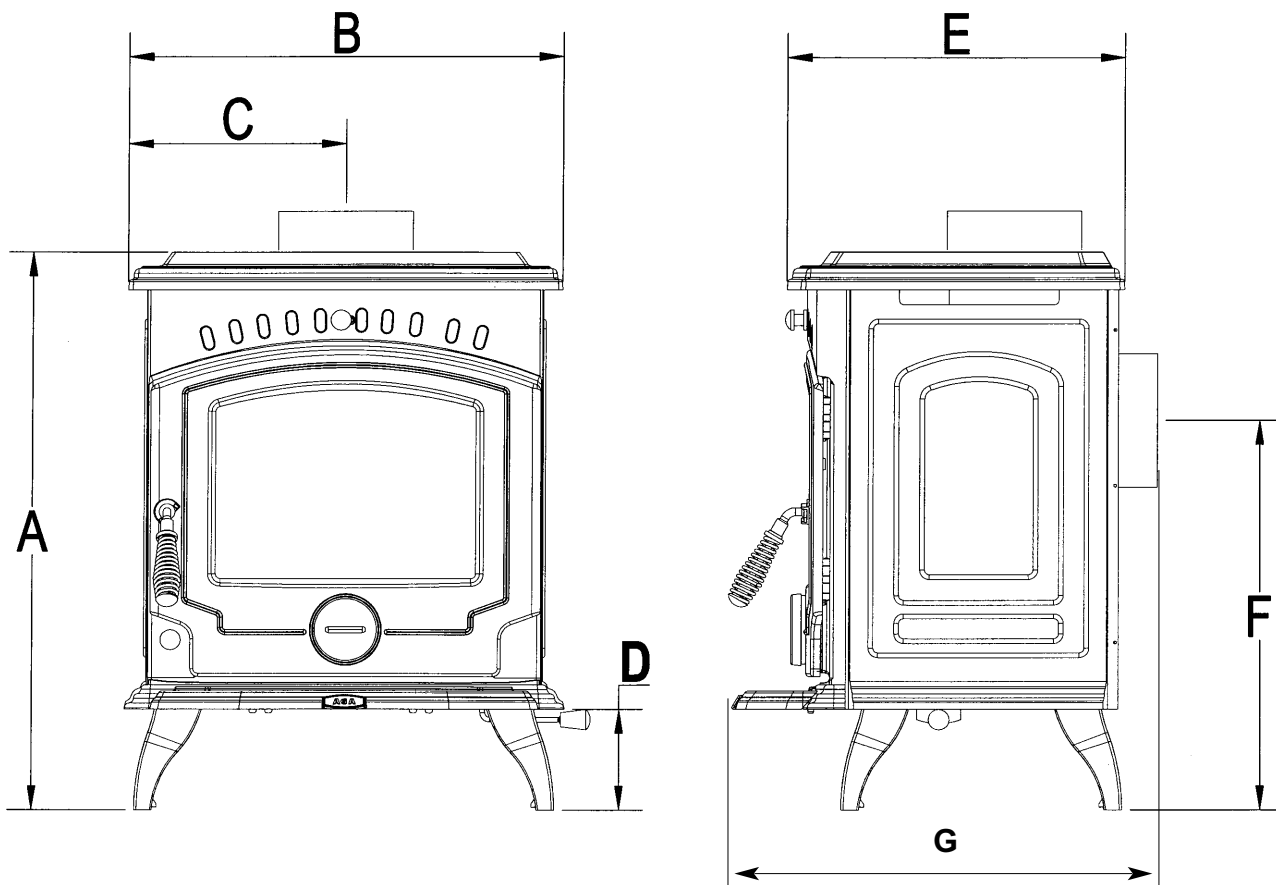

Dimensions	A	B	C	D	E	F	G
Metric (mm)	700	542	271	165	423	476	530
Imperial (inches)	27 ⁴ / ₈	21 ³ / ₈	10 ⁵ / ₈	6 ⁴ / ₈	16 ⁵ / ₈	18 ⁶ / ₈	20 ⁷ / ₈

SPECIFICATIONS

	METRIC
Flue Outlet	150mm
Fire Door Size	320 x 210mm
Log Size	300mm
Gross Weight	137 KG

TECHNICAL DATA

	Non Boiler
Nominal Output Wood Logs	5.5 kW
Solid Mineral Fuel	4.1 kW

Typical refuelling intervals to obtain nominal outputs:

- 1.5 hours wood
- 4 hours solid mineral fuel

Fig.6

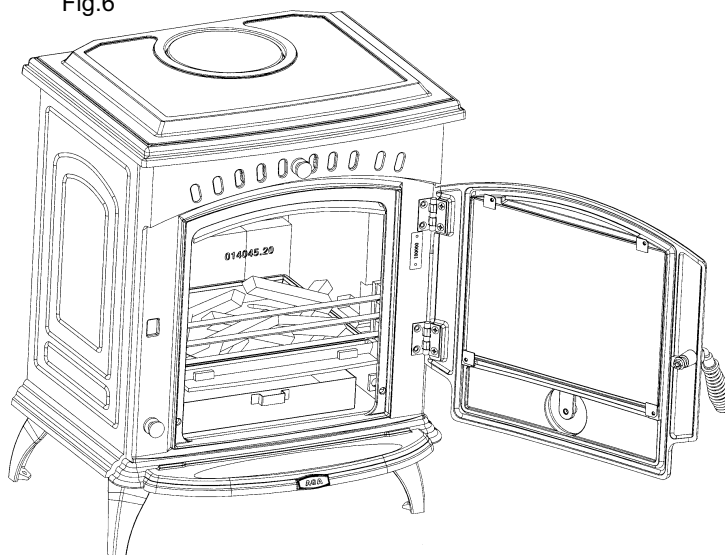

WARNING: DO NOT OBSTRUCT PRIMARY AIR SUPPLY TO THE SPIN VALVE AT THE FRONT OF THE STOVE.

LIGHTING

1. Before lighting the stove, ensure that any build up of ashes in the fire box has been removed and that the ashpan has been emptied.
2. Open the firebox and cover the grate with crumpled pieces of paper.
3. Lay pieces of kindling on top of the paper towards the back of the fire box.
4. Open the primary air inlet by turning the spin valve at the front of the stove anticlockwise. (See Fig.7).
5. Open the secondary air control by sliding the control knob located over the top of the fire door to the left (See Fig.7a).
6. Ignite the paper and close the firedoor.
7. When the kindling is well alight, open the fire door and add more kindling of a larger size to sustain the fire. Close the firedoor. Do not operate this appliance with the firedoor open.
8. Never use inflammable liquid i.e. gasoline, petrol paraffin etc. to start or freshen up a fire in this heater.
9. When a hot bed of fuel is established, add the normal fuel and adjust the spin valve to the required setting.
10. When re-fuelling open the firedoor and reload, close the firedoor.
11. To shut the fire down, do not add fuel, make sure that the firedoor is properly closed and that the primary secondary and tertiary air controls are all in the closed position. Cutting off the air supply will reduce the heat output.

**This appliance is hot whilst in operation.
Keep children, clothing and furniture a safe distance away.**

IMPORTANT NOTES

Now that your AGA Solid Fuel Stove is installed and no doubt you are looking forward to many comforts it will provide, we would like to give you some tips on how to get the best results from your stove.

1. We would like if you could take some time to read the operating instructions/hints, which we are confident, will be of great benefit to you.
2. Do not burn fuel with a high moisture content, such as a damp peat or unseasoned timber. This will only result in a build up of tar in the stove and in the chimney.
3. Clean the flue-ways of the stove regularly and ensure that there are no blockages. Check flue ways before lighting especially after a shut down period.
4. Before loading fresh fuel into the firebox, riddle fully to remove all ashes, this will allow better and cleaner burning. See Re-Fuelling Section Page 10.
5. Never allow a build up of ashes in the ash pan, as this will cause the grate to burn out prematurely.
6. Avoid slow burning of damp or unseasoned fuel as this will result in tarring flue ways and chimney i.e. peat or timber.
7. Allow adequate air ventilation to ensure plenty of air for combustion.
8. Do not use as an incinerator burning rubbish/household waste.
9. Do not leave fire door open for long periods as this will over heat the unit causing unnecessary damage.
10. Clean the chimney at least twice a year.
11. Burning soft fuels such as timber and peat will stain the glass. Regular cleaning will prevent permanent staining.
12. Keep all combustible materials a safe distance away from unit, please see Installation Clearances Page 5.
13. For safety reasons never leave children or the elderly unaccompanied while stove is in use. Use a fire guard.
14. Avoid contact with the appliance when in use as stove reaches very high operating temperatures.
15. This appliance should be regularly maintained by a competent service engineer. Use only replacement parts recommended by AGA. Making unauthorised modifications, or using unauthorised parts will invalidate your guarantee and may cause damage or injury.

OPERATING INSTRUCTIONS

CAUTION!

“Never use gasoline” gasoline type lantern fuel, kerosene, charcoal lighter fluid or similar liquids to start or ‘freshen up’ a fire in this heater. Keep all such liquid well away from the heater at all times. Operate stove only with fuelling door closed. This heater is hot whilst in operation. Keep children, clothing and furniture a safe distance away.

Fig.7

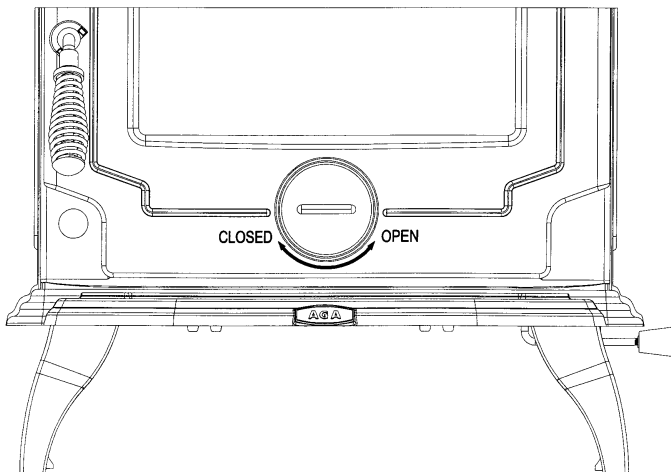
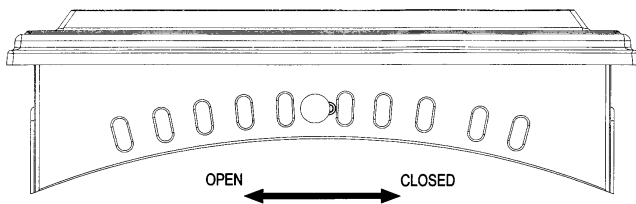

Fig.7a



PRIMARY AIR SETTINGS

The spin valve (Part No. 33), located at the bottom end of the door, controls the primary air supply to the stove. For maximum heat output and burn rate rotate the spin valve (Part No. 33) fully in an anti-clockwise direction and for a minimum heat output and burn rate rotate the spin valve clockwise until fully closed. For nominal heat output the spin wheel needs to be open between 1 – 2 turns. You will soon learn the spin valve settings to best suit your requirements. When burning wood logs the primary air control should be closed and the secondary air wash should be used to control the rate of burn. Opening the slider less than halfway should be enough to obtain nominal output. It is important to use this air control when burning manufactured smokeless fuels. The air passing over the grate will help to cool it and will prevent premature failure.

IMPORTANT: The first few fires should be relatively small to permit the refractory to set properly and to season the stove.

RECOMMENDED FUELS

This appliance has been tested using seasoned wood logs and manufactured briquetted smokeless fuel (Ancit) for closed appliances, sized between 20g and 140g. Other fuels are commercially available and may give similar results. Wood logs up to 300mm long are suitable. All fuels should be stored under cover and kept as dry as possible prior to use. Do not use fuels with a coke ingredient as this may cause the grate to overheat, causing damage. Reduced outputs will result when fuels of lower calorific values are used. Never use gasoline or gasoline type lantern fuel, kerosene, charcoal lighter fluid or similar liquids to start or freshen up a fire in this heater. Keep all such liquid well away from the heater at all times. Operate the stove only with the fuelling door closed except for re-fuelling.

AIR WASH SETTINGS

The following settings should be observed for the Air Wash Shutter (Fig. 8) when burning the specified fuels.

Note: This part can become very hot. Always use the operating tool when opening and closing the Air Wash Shutter.

OPEN When burning house coal, timber or peat. Using this control when burning these fuels will help to keep the glass clean.

CLOSE When burning anthracite and manufactured smokeless fuels.

Fig 8

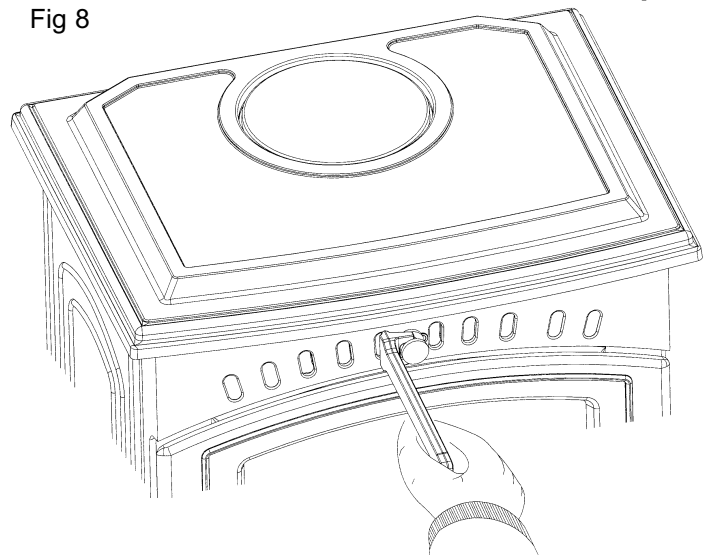

TERTIARY AIR / SYSTEM CONTROL

The stove has a Tertiary Air System located at the top, under the roof baffle and connected to an air feed ducting on the right hand side and controlled by a push pull slider assembly, located at the bottom right hand side.

OPERATION

To operate the Tertiary Air, push to open and pull to close. Open tertiary air slider only when the fire is established.

Note: Close off the tertiary air for overnight burn.

WARNING: THE AIR SLIDER IS HOT WHILE STOVE IS IN USE - USE TOOL TO OPERATE.

OVERNIGHT BURNING

To achieve an overnight or a slow burn rate, close the Air Wash Shutter fully, close the front spin valve fully then open about half a turn, or less, depending on draught conditions. If the fuel load is too small or the draught too strong the spin valve may need to be closed even further to sustain the low burn rate. This will be found by trial and error by adjusting the amount of air depending upon the amount of fuel left over at the end of the burning period.

REMEMBER: Coal gases are toxic so ensure there is sufficient draught to take the flue gasses up the chimney and not into the room.

WARNING: Failure to comply with the Installation and Operating Instructions outlined above may result in carbon monoxide entering the house rather than being drawn up the chimney.

RE-FUELLING

Riddle the fire by connecting the grate operating tool onto the rocker connection located at the bottom front of the stove, then gently pull and push the rocker arm until all dead ash has fallen through into the ashpan. Before opening the door, open the spin valve by turning it anti-clockwise, as this will help to eliminate any smoke or fly ash resident in the combustion chamber. Add fuel to the fire, taking care not to over fill. Close fire door and re-set the spin valve to the required setting.

DE-ASHING

Never allow the ashpan to over fill as it will cause damage to the grate. When ash build-up becomes excessive in the fire chamber riddle the fire until all dead ash has fallen through to the ashpan. Open the front door (Part No.14) and remove ashpan (Part No.11) using the operating tool (Part No.1). Close the front door (Part No. 14). When the ash is disposed of, replace the empty ashpan. Do not leave this appliance with the loading door open even for a short time.

Fig.9

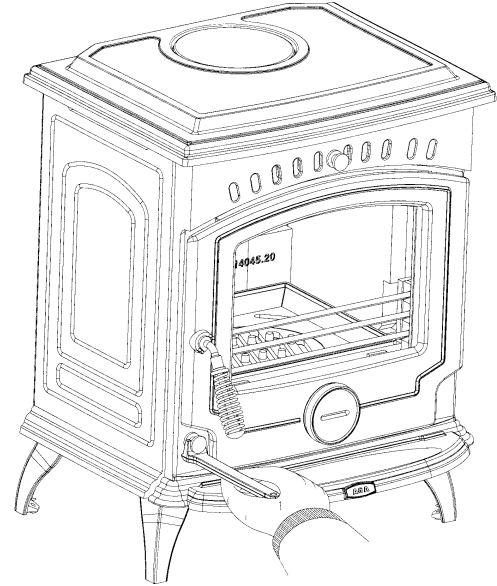

DISPOSAL OF ASHES

The ashpan must be emptied every day. If ashes are allowed to build up to grate level the fire box insert could be damaged by overheating. We recommend that you remove ashes after you have riddled the fire. Ashes can be very hot and should be placed in a metal or other non-combustible container with a tight fitting lid. The closed container of ashes should be placed on a non-combustible material, pending final disposal. If ashes are buried in soil, or otherwise dumped they should be retained in the closed container until they are thoroughly cooled. Fig.10

Fig. 10

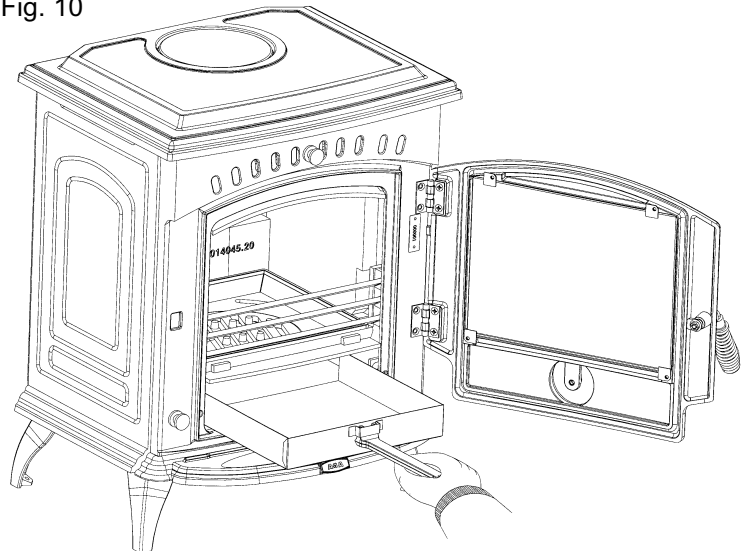

TO CLEAN CHIMNEY OUTLET

Remove the back bricks and the side bricks. Remove the fire fence (3 off) and lift the baffle from its supports, then move it forward to clear the support at the rear. Drop rear of baffle and rotate it until the baffle is upside down on top of the firebed. Lift one side of the baffle to allow it to be removed through the front opening. Ensure the tertiary air pipe is sealed to the right hand side with fire cement.

FIRE SAFETY

To provide reasonable fire safety, the following should be given serious consideration.

1. Do not over fire the stove.
2. Over-firing will also damage painted or enamel finish.
3. Install a smoke detector in the room.
4. A conveniently located class A fire extinguisher to contend with small fires resulting from burning embers.
5. A practical evacuation plan.
6. A plan to deal with a chimney fire as follows:-
 - (a) Notify the fire department.
 - (b) Prepare occupants for immediate evacuation.
 - (c) Close all openings into the stove.
 - (d) While awaiting the fire department watch for ignition to adjacent combustibles from over heated stove pipe or from embers or sparks from the chimney.

VITREOUS ENAMEL CLEANING

General cleaning must be carried out when the stove is thoroughly cool. If this stove is finished in a high gloss vitreous enamel, to keep the enamel in the best condition observe the following tips:

1. Wipe over daily with a soapy damp cloth, followed by a polish with a clean dry duster.
2. For stubborn deposits a soap impregnated pad can be carefully used on the vitreous enamel.
3. Only products recommended by the Vitreous Enamel Association, carry the Vitramel label.
4. **DO NOT USE ABRASIVE PADS OR OVEN CLEANSERS CONTAINING CITRIC ACID ON ENAMELLED SURFACES. ENSURE THAT THE CLEANSER MANUFACTURERS INSTRUCTIONS ARE ADHERED TO.**

GLASS CLEANING

The glass will self clean when there is sufficient heat generated by the burning fuel. If a build-up of creosote occurs on the glass it may be due to draught conditions, poor quality damp fuel or very low burning for a long time. It is best to clean the glass when it is thoroughly cooled.

Fig 11

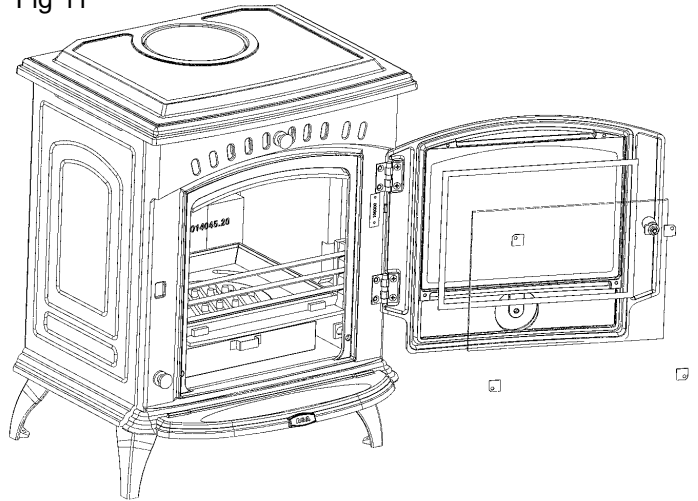

GLASS REPLACEMENT

- (a) Open the front door fully.
- (b) Remove the four corner screws and clips and carefully remove the broken glass.
- (c) Clean the glass recess in the door.
- (d) Attach adhesive thermal tape to the perimeter of the replacement glass.
- (e) Place the thermal tape side of the glass into the door recess and replace the four corner clips.
- (f) Tighten screws.
- (g) Replace glass only with ceramic glass 5mm thick. (See Fig.11)

EXPLODED VIEW

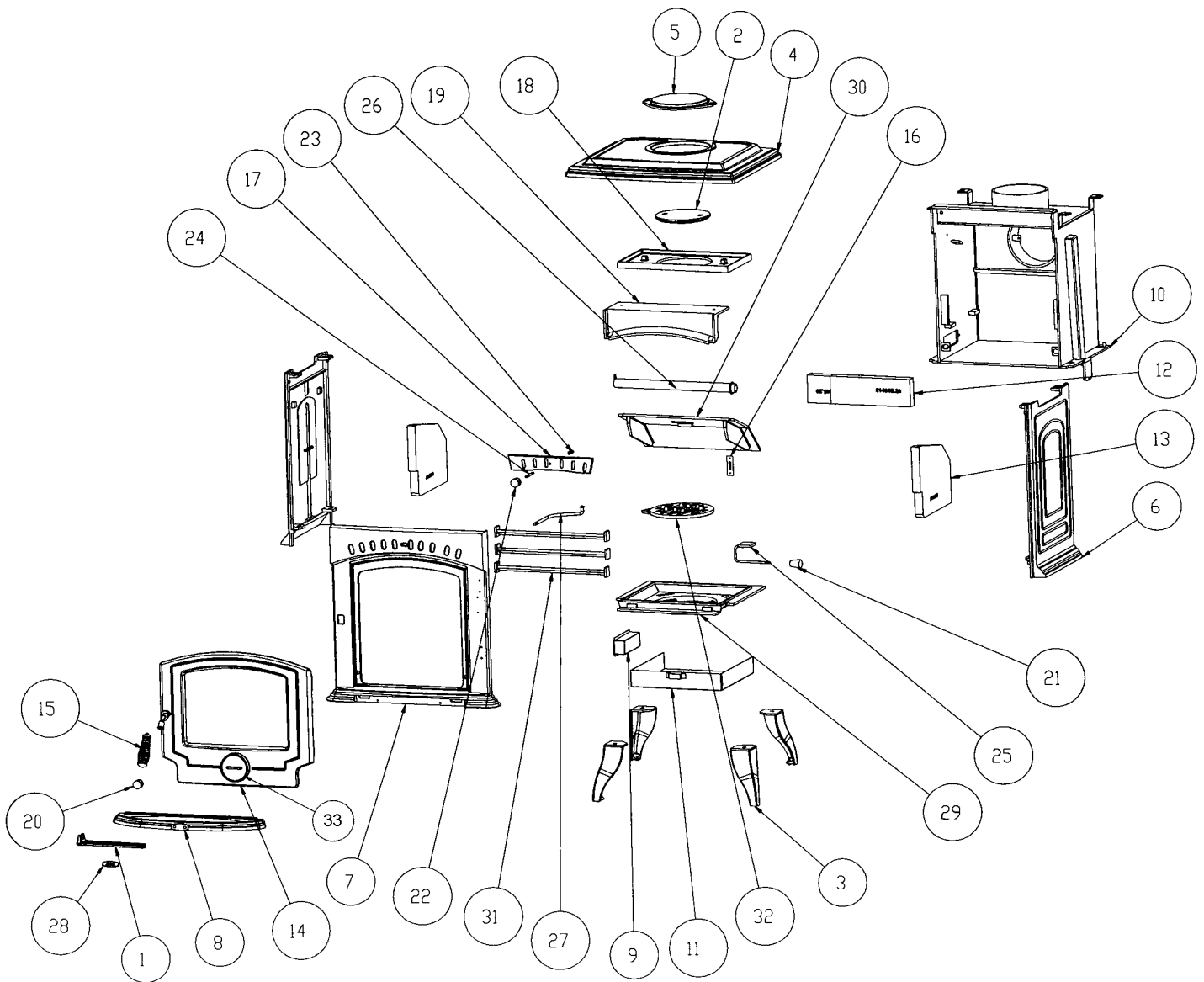

ITEM DESCRIPTION	QTY		
1. OPERATING TOOL	1	17. AIR WASH PLATE	1
2. FLUE BLANKING PLATE	1	18. DRY SHELL PROTECTION PLATE	1
3. LEG	4	19. AIR WASH PLATE	1
4. HOB	1	20. PULL ROD KNOB	1
5. HOB BLANKING PLATE	1	21. KNOB SECONDARY AIR DAMPER	1
6. SIDE PANEL	2	22. AIR WASH KNOB	1
7. FRONT PANEL	1	23. SPRING	1
8. ASHTRAY FRONT	1	24. AIR WASH SHUTTER SHAFT	1
9. PULL ROD BOX	1	25. TERTIARY AIR DAMPER	1
10. DRY SHELL	1	26. TERTIARY AIR TUBE	1
11. ASHPAN	1	27. PULL ROD	1
12. BACK BRICKS	2	28. AGA STOVE BADGE	1
13. SIDE BRICK	2	29. FIRE BOX INSERT	1
14. DOOR ASSEMBLY	1	30. FLUE CLEANING PLATE	1
15. COIL HANDLE ASSEMBLY	1	31. FIRE FENCE	3
16. SERIAL NUMBER PLATE	1	32. GRATE	1
		33. SPIN VALVE	1



Aga,
 Station Road,
 Ketley, Telford,
 Shropshire, TF1 5AQ,
 UK