

# ICS

## INSTALLATION INSTRUCTIONS

80 - 250mm Internal Diameter  
Twin Wall Insulated Chimney System  
for gas, oil, wood and multi-fuel applications

# CONTENTS

Page 2 **Approvals**

Page 3 **Design Guide**

- Mandatory Requirements
- Inspection
- Chimney Diameter
- Chimney Route
- Ventilation

Page 4

- Provision for Condensate Disposal
- Distance to Combustibles
- Enclosure/Shafts

Page 5

- Connection to Draught Diverter
- Appliance/Chimney Connection
- Chimney Termination
- Terminals
- Support Components
- Delivery to Site and Storage
- Painting
- Handling

Page 6 **Installation Instructions**

- Jointing System
- Standard Chimney Sections

Page 7 - Individual Components

Page 10 **Offset Dimensions**

Page 11 **BS EN 15287-1**

- Acceptable Alternative Methods of Connection

Page 13 **Firestop Components**

Page 14 **Support Components**

Page 19 **Outlet Siting**

Page 20 **Typical External Installations**

Page 21 **Load Bearing Data**

Page 22 **Component Weights**

Page 22 **After Installation**

- Testing Before Use
- Maintenance

Page 23 **Chimney Plate**

Page 23 **Product Warranty**

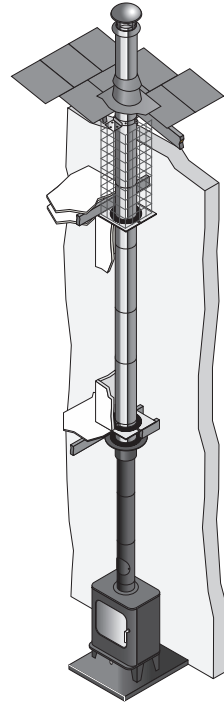

## APPROVALS

ICS is CE Certified to EN1856-1 TÜV 0036 CPD 9195001 with designations:

High Temperature Applications		Low Temperature Applications
T450 NI W V2 L50050 G60 T450 NI D V3 L50050 G60 60mm distance to combustibles in a combustible shaft *	T450 NI W V2 L50050 G50 T450 NI D V3 L50050 G50 50mm distance to combustibles in a non combustible shaft or in free air *	T200 PI W V2 L50050 O00 Zero distance to combustibles *

\* For full information please see p.3 - Distance to Combustibles Section

- Manufactured under a Quality Management Scheme approved to BS EN ISO 9001:2008
- 4 Hour Fire Rating to BS476 Part 20
- Certified for corrosion resistance on gas, oil and solid fuel by Gastec, MPA and TÜV
- HETAS listed for use on solid fuel applications.



## DESIGN GUIDE

### Mandatory Requirements

Connection to an appliance which is not connected to the fuel supply, may be carried out by a competent person. However, connection to an appliance that is connected to the fuel supply must be carried out by a GAS SAFE (gas) or OFTEC (oil) registered installer. We recommend the use of HETAS approved installers for solid fuel applications.

The design guide must be read in conjunction with the detailed component installation instructions. For full design and installation details the key referral documents are:

- **BS EN 1856-1**: Chimneys - System Chimney Products
- **BS EN 1859**: Metal Chimneys - Testing Methods
- **BS EN 1443**: Chimneys - General Requirements
- **BS EN 15287-1**: Chimneys. Design, installation and commissioning of chimneys. Chimneys for non-room sealed heating appliances.
- **BS 5440-1**: Fluing and ventilation for gas appliances of rated input not exceeding 70kW net (1st, 2nd and 3rd family gases). Specification for installation of gas appliances to chimneys and for maintenance of chimneys.
- **Approved Document J**: - Combustion appliances and fuel storage systems (England & Wales)
- **DFP Technical Booklet L**: - Combustion appliances and fuel storage systems (NI)
- **Technical Handbook (Domestic & Non Domestic), Section 3** - Environment (Scotland)
- **BS EN 14241-1**: Chimneys - Seals in flue liners.
- **Appliance Installation Instructions** and related standards. Other standards covering specific applications will also be relevant and must be adhered to.

Planning permission for a System Chimney may be required, and reference should be made to the local Building Control Department.

### Inspection

To conform to Building Regulations, provisions should be made to enable a chimney to be inspected and cleaned. An inspection length or an insulated 90° or 135° Tee can form a suitable inspection point (unless cleaning/inspection can be done through the appliance). To aid cleaning, sufficient distance should be left between changes of direction to permit the safe passage of cleaning brushes within the system. This is particularly important on solid fuel applications. It is recommended that chimneys serving solid fuel appliances be swept as frequently as necessary, but at least twice a year.

### Chimney Diameter

The chimney size should be as recommended by the appliance manufacturer. Where there is a requirement for a flue diameter smaller than the appliance spigot, then the operational requirements of the appliance and the configuration of the flue must satisfy the flue sizing requirements of EN 13384-1 for single appliances, and EN 13384-2 for multi appliances.

### Chimney Route

The chimney should remain as straight as possible through its vertical run to assist flow. Should it be necessary to offset a chimney run then the following guidelines should be adhered to:

It is recommended that a vertical run of at least 600mm should be allowed immediately above the appliance prior to any change of direction. Within a system, on all fuels, there should be no more than 4 changes of direction of maximum 45°. 90° Factory made bends or tees within the system may be treated as being equal to two 45° bends (as per Document J of the Building Regulations issued October 2010).

### Ventilation

It is very important that sufficient air for combustion and ventilation is provided to the room containing the appliance, to enable correct and efficient working of the appliance and chimney system. Reference should be made to the appliance manufacturer's instructions and recommendations are also given in the Building Regulations Document J, CIBSE guidance notes and BS 5440.

### Provision for Condensate Disposal (subject to appliance manufacturer recommendations)

Condensing appliances need provision for drainage. Choose appropriate flue drainage components, normally fitted at the base of the stack and close to the appliance outlet. A 3° slope on horizontal runs must be maintained, using the appropriate 87° bend and 93° tee.

### Distance to Combustibles

In accordance with building regulations, it is essential that the correct distance to combustible material is maintained. On **solid fuel** applications, where there is a risk of soot fire, a distance of **60mm to combustibles** must be maintained within a **combustible floor** and within a **combustible shaft** (see Fig.1). There is no need to line the area within the floor cavity with plasterboard; however the **ventilated fire stop plate** and **ventilated support plate** must be used.

On **gas and oil** applications, a distance of **50mm to combustibles** must be maintained within a **combustible floor** and within a **combustible shaft**. The **ventilated fire stop plate** and **ventilated support plate** must be used.

Where the chimney penetrates a **non combustible** floor and where a **non combustible** shaft is used, a distance of **50mm to the shaft** is sufficient. In this case, **non ventilated fire stop plates and support plates** may be used with a **ventilated fire stop** being used where the chimney penetrates into the **roof space**.

On bungalow applications where the chimney runs through either a combustible or non-combustible ceiling, an unventilated bungalow fire stop plate kit can be used. Please note that an unventilated support plate can not be used above the ceiling in this case. The weight of the chimney should be supported using the roof support (see p.12). Distance to combustibles must be respected within the ceiling space (see Fig. 2) and mesh frame should be used within the loft space, which must be ventilated (see Fig. 2).

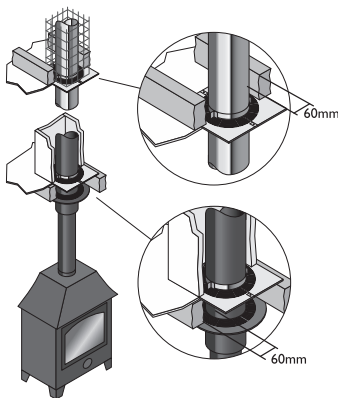

**Fig. 1**  
**Internal House**  
Combustible Floors

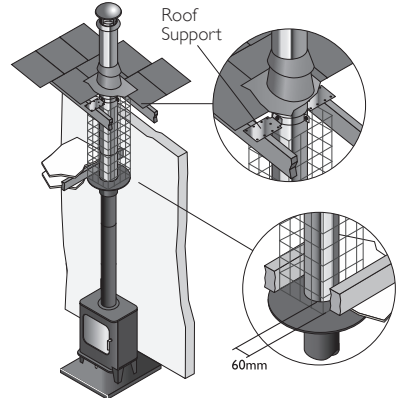

**Fig. 2**  
**Internal Bungalow (Ventilated Loft Space)**  
Combustible and Non-Combustible Floors

### Enclosure/Shafts

With the exception of the room containing the appliance, where the chimney passes through any part of the building, where there is a risk of accidental human contact, i.e a bedroom etc., or where there is a risk of contact with combustible materials stored in a cupboard or in the roof-space, the chimney must be enclosed in an appropriate way to meet Building Regulations. This can be achieved by boxing in the chimney in habitable rooms, or by the use of a protective wire mesh frame in roof spaces etc. In all cases the minimum distance to any combustible material, including loft insulation, must be respected according to the table on p.1, and any enclosure should be ventilated using the appropriate ventilated fire stops (see p.8).

## Connection to Draught Diverter

Where the appliance features a draught diverter the connection should rise vertically from it for at least 600mm before any change of direction (unless otherwise specified by the appliance manufacturer). This is in accordance with the recommendations contained in BS 5440 Part 1 section 4.1.5.

## Appliance/Chimney Connection

This must be done by using the appropriate appliance connector. When a single wall connecting flue pipe is used to connect an appliance to the chimney, the lower end of the chimney section must extend a minimum of 425mm below the ceiling. When connecting the appliance to the flue pipe all joints between the flue pipes/appliance outlet must be securely caulked and sealed with non asbestos rope (or suitable alternative) and fire cement on solid fuel appliances and using the appropriate lip seal gasket in the case of condensing appliances.

Any flue pipe connection to the chimney MUST be made in the same room as the appliance.

## Chimney Termination (refer to page 14)

Flue termination for solid fuel and oil are subject to EN 15287-1.

Flue terminations for gas appliances up to 70kW are governed by BS5440-1 Section 4.2. The illustrations on page 14 give recommendations for the most common siting situations encountered. Adjacent taller structures may require increased height.

## Terminals

All terminals must be secured with the use of a locking band. On solid fuel appliances, an open termination is normally recommended. However in certain conditions, rain caps or anti-downdraught terminals may be used.

Rain caps and anti-downdraught terminals are available in two versions, with anti bird mesh and without mesh. Where a terminal with mesh is used, there is a risk of soot build up, and therefore regular cleaning is required to avoid blockage, particularly when using oil or solid fuel.

## Support Components

The weight of a chimney system is considerable and requires independent support. Minimal weight should be borne by the appliance. The weight of the chimney can be supported from floor level by using a base support plate, or floor support; from the wall by using wall support top plates together with side plates or cantilever brackets; or from first floor level by using a support plate and clamp fixed to the floor/ceiling joists.

Wall brackets are **non load bearing** and provide lateral support only. Refer to the load bearing tables on page 16 for full details of maximum loadings.

Where the flue is freestanding above the roof and its height exceeds 1.5m above the last support or above the roof, a guy wire bracket must be used and every 1.5m thereafter in conjunction with guy wires or rigid stays (provided by others). Alternatively a height of up to 3m can be achieved unsupported using extended locking bands at the joint immediately below the last support and on every joint above it.

## Delivery to Site and Storage

Components should be carefully transported and off loaded. They should be inspected to ensure they have not been damaged, and should be stored off the ground and under cover so that they are protected from accidental damage and the adverse effects of weather:

## Painting

If painting of any external sections is required, it is important to de-grease, dry and prime the exterior surface prior to the application of appropriate heat resistant paint.

Schiedel Chimney Systems can provide to special order, chimney sections and accessories painted to an extensive range of British Standard RAL colours – details on application.

## Handling

It is advised that suitable PPE should be used when handling the products.

# INSTALLATION INSTRUCTIONS

## Jointing System

All joints in the ICS chimney range, which require a locking band, are made by means of a simple push fit jointing method. This is achieved by the engineered spigot and socket system having a pronounced lead-in-edge to ease assembly.

**ICS Plus** is created by adding a lip seal gasket into the inward bead on the liner of the standard components, which are suitable for use in condensing applications with a PI designation. When installing ICS Plus components, Gaskets should be fitted dry and lubricant applied to the internal of the female liner socket (see Fig. I below)

### ICS

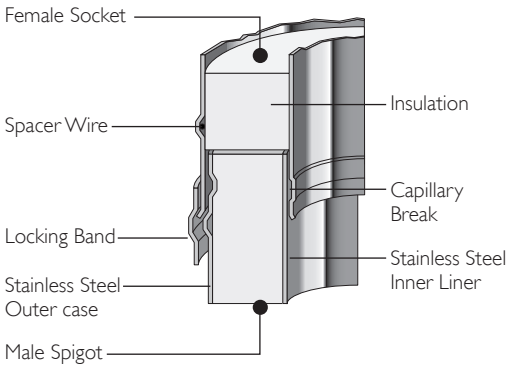

### ICS Plus

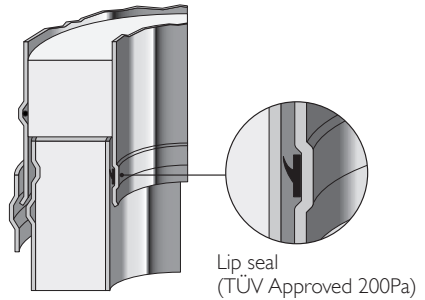

## Standard Chimney Sections (Pipes, Tees and Elbows)

Before assembling chimney sections, slip a locking band over female socket of the chimney section. Ensure the sections are pushed tightly together; before securing the locking band by use of the quick release clip. The clip can then be tightened into place by using the tightening bolt. Note:-joints must NOT occur within floor or ceiling spaces.

All flue gas carrying components must be installed with the direction arrow on the product label pointing to termination with the external male spigot of the case uppermost.

**Fig. I**

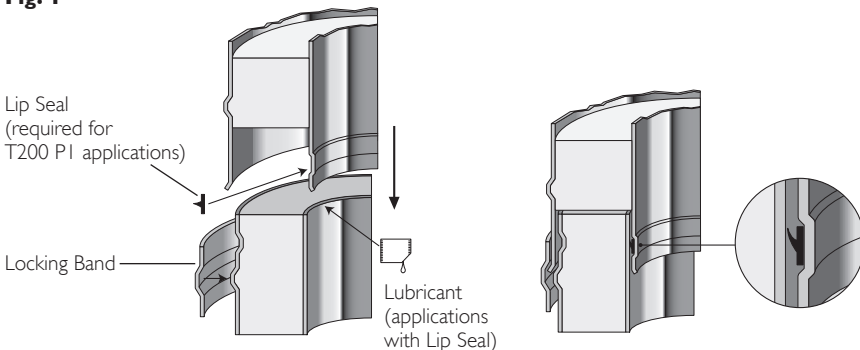

## Locking Band (supplied with each component with a female socket on the case)

A locking band must be fitted to every joint in the system. The band is of stainless steel construction and is fitted with a quick release clip and a stainless steel tightening bolt. The bolt can be adjusted to ensure the joint is firmly secured.

## Structural Locking Band

The structural locking band, which is purchased separately, is used instead of a standard locking band in a situation where extra structural support is required, for instance where the chimney height is >1.5m above the last support or above the roof. It is also used to provide extra support in long horizontal runs. A maximum of 3m unsupported height can be achieved by fitting the structural locking band on the joint immediately below and on every joint above the last support. Please see diagram on page 16.

## Appliance Connector/Starting Connector/Stove Starter Pipe

1. The protruding liner of these components should be pushed into the appliance spigot with the external male case spigot pointing upwards.
2. On solid fuel appliances the appliance connector should be sealed to the appliance with fire rope and fire cement or high temperature sealant to provide a gas tight joint. On condensing appliances the appropriate lip seal should be used.

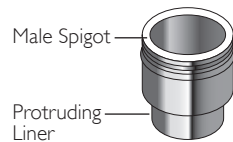

**Appliance Connector**

## Adaptors from Prima Plus & Prima Smooth to ICS

These components are used to convert from a single wall connecting flue pipe to the ICS system chimney. The protruding liner should be pushed down inside the female socket of the connecting flue pipe, with the double wall external case spigot pointing in the direction of the flue gases.

## Adaptor to Flex/Tecnoflex

This component is used to convert from ICS to Flex/Tecnoflex. The Flex/Tecnoflex is pushed down inside the upstand on the adaptor; secured using self tapping screws and sealed with fire cement and fire rope to provide a gas tight joint.

## Adaptor from ICS to Prima Plus

This component is manufactured with an ICS female socket and a Prima Plus female socket, and is used where there is a requirement to convert from ICS to Prima Plus. The ICS female socket should be attached to the previous ICS component and the joint secured using the locking band provided.

## Increaser

This component is used to increase from one diameter to the next diameter (e.g. 200mm to 230mm). The component is fitted in the same way as a standard pipe length and should be secured with the locking band provided.

## Anchor Plate

When commencing an installation with a fire chest, hood or similar, or when extending an existing brick or masonry chimney stack, an anchor plate must be used.

The liner of the Anchor Plate should be pushed into the opening of the fire chest with the plate resting on a bed of fire cement. The plate should then be fixed onto the concrete slab by masonry screws fitted through the pre-drilled holes in the plate.

In the case of a chimney extension, the liner of the anchor plate fits down inside the existing chimney stack, or if a chimney liner has been used, inside the chimney liner; to which it should be secured using self tapping screws and sealed with fire cement and fire rope. The plate should then be bolted to the top of the existing chimney and sealed using fire cement.

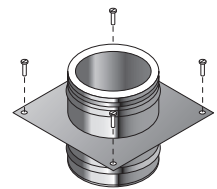

**Anchor Plate**

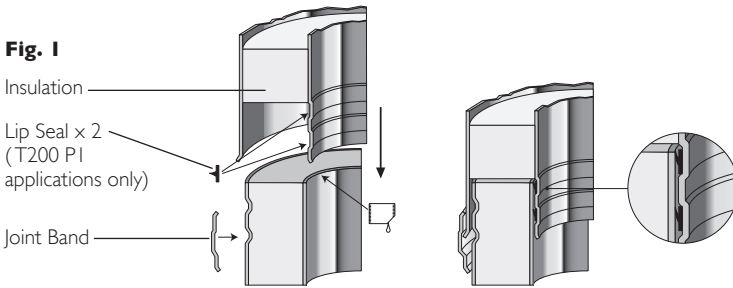

### Adjustable Pipe

The adjustable pipes are delivered as two pre-assembled sections with a joint band and locking band (see Fig.1). They are used with standard components to achieve an exact length on site and avoid on-site cutting of components.

1. Calculate the length required. Loosen the joint band and remove the top section of the adjustable pipe.
  2. Remove insulation as required to achieve the correct length.
  3. Re-assemble the pipe and cover the joint with the joint band.
  4. Fix the adjusted section to standard components using the locking band provided.
- Please note that the adjustable pipe is non load bearing.

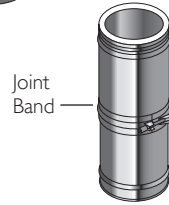

**Adjustable Pipe**

### Inspection Length (Dry Systems)

The inspection length is a component providing the facility for flue inspection and cleaning. It is installed as per a standard pipe section.

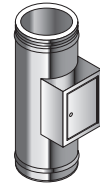

**Inspection Length (Dry Systems)**

### Inspection Length (Condensing Systems)

The inspection length is a component providing the facility for flue inspection and cleaning on condensing or high efficiency appliances with a maximum flue gas temperature of 250°C, and a positive pressure rating of up to 200 Pa. It is installed as per a standard pipe section.

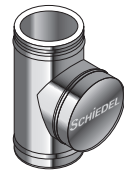

**Inspection Length (Condensing Systems)**

### Inspection Pipe

The Inspection pipe is a component which provides the facility to inspect the flue. It is installed as per a standard pipe section.

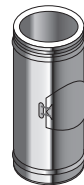

**Inspection Pipe**

### Measure Pipe

The measure pipe is a component which provides access to the flue for draught testing or for flue gas analysis. It is installed as per a standard pipe section.

### Vertical Drain Pipe

This component is used on condensing systems and provides the facility to collect and drain off condensate from the chimney. It is installed in the same way as a standard pipe. It is provided as standard with a 3/4" BSP fitting.



## Elbows and 90° Inspection Elbows

For offset information on standard elbows, please refer to p.9

Please note that 90° Inspection bends may be incorporated into a connecting flue pipe arrangement on all fuels, please refer to National Annex of BS EN 15387-1 for specific guidance re use on solid fuel applications, the diagrams on p.10-11 give guidance, and should be read in conjunction with the approved.

In cases of top mounted stoves, a minimum vertical height of 600mm from the appliance must be respected prior to any change of direction in the flue pipe.

### 90° Tee

This component may be used to connect from a connecting flue pipe to the vertical system chimney at 90° or the branch may be used to locate a draft stabiliser. It is installed as per a standard pipe section.

Int Ø	80	100	130	150	180	200	230	250
Ext Ø	130	150	180	200	230	250	280	300
A	145	155	170	180	195	205	220	230
B	250	270	305	325	355	375	405	425
C	145	155	170	180	195	205	220	230

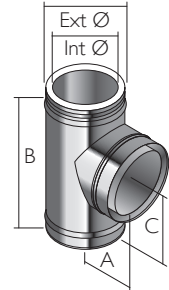

90° Tee

### 93° Tee

This component must be used in place of a 90° tee to connect from a connecting flue pipe to the vertical System Chimney on condensing systems to ensure that condensate can drain down through the system to a drain point. This component is installed as per a standard pipe section.

Int Ø	80	100	130	150	180	200	230	250
Ext Ø	130	150	180	200	230	250	280	300
A	151	166	178	189	206	216	233	257
B	151	162	178	189	206	216	233	244
C	249	278	309	329	359	379	405	455

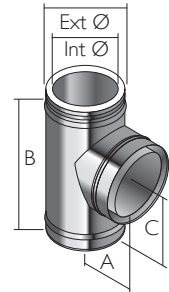

93° Tee

### 135° Tee

This component may be used in combination with a 45° elbow to connect from a connecting flue pipe to the vertical system chimney. It is installed as per a standard pipe section and provides the least resistance to the flow of the flue gases.

Int Ø	80	100	130	150	180	200	230	250
Ext Ø	130	150	180	200	230	250	280	300
A	238	262	298	322	358	382	419	443
B	299	327	375	403	445	474	516	544
C	238	262	298	322	358	382	419	443

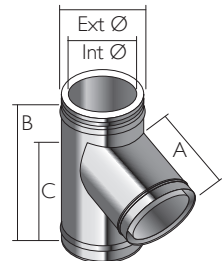

135° Tee

## OFFSET DIMENSIONS

(made by assembling 2 bends)

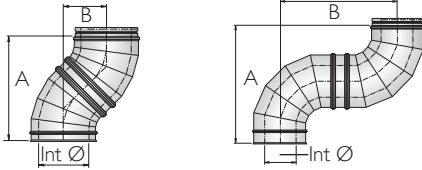

### Offsets for Double 15° Bend

Int Ø	80	100	130	150	180	200	230	250
A	295	295	295	295	315	315	315	334
B	39	39	39	39	41	41	41	44

### Offsets for Double 30° Bend

Int Ø	80	100	130	150	180	200	230	250
A	280	299	327	336	355	373	373	392
B	75	80	88	90	95	100	100	105

### Offsets for Double 45° Bend

Int Ø	80	100	130	150	180	200	230	250
A	307	324	341	358	376	393	427	427
B	127	134	141	148	156	163	177	177

### Offsets for Double 90° Bend

Int Ø	80	100	130	150	180	200	230	250
A	300	316	348	366	396	420	452	468
B	300	316	348	366	396	420	452	468

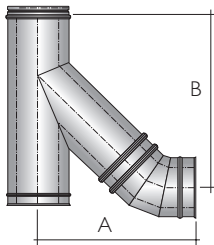

### Offsets for Double Tee° Bend & 45° Bend

Int Ø	80	100	130	150	180	200	230	250
A	343	370	437	445	452	496	523	537
B	305	324	404	406	415	473	475	499

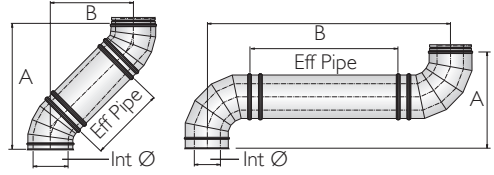

### Double 15° Bend C/W Pipe Length

Int Ø mm	80	100	130	150	180	200	230	250
955 Eff Pipe	A 1218	1218	1218	1218	1238	1238	1238	1257
	B 286	286	286	286	288	288	288	291
455 Eff Pipe	A 735	735	735	735	755	755	755	774
	B 157	157	157	157	159	159	159	162
205 Eff Pipe	A 493	493	493	493	513	513	513	532
	B 92	92	92	92	94	94	94	97
150 Eff Pipe	A 445	445	445	445	465	465	465	484
	B 79	79	79	79	81	81	81	84

### Double 30° Bend C/W Pipe Length

Int Ø mm	80	100	130	150	180	200	230	250
955 Eff Pipe	A 1107	1126	1154	1163	1182	1200	1200	1219
	B 553	558	566	568	573	578	578	583
455 Eff Pipe	A 674	693	721	709	765	765	784	784
	B 303	308	316	318	323	328	328	333
205 Eff Pipe	A 458	477	505	514	533	551	551	570
	B 178	183	191	193	198	203	203	208
150 Eff Pipe	A 414	433	461	470	489	507	507	526
	B 153	158	166	168	173	178	178	183

### Double 45° Bend C/W Pipe Length

Int Ø mm	80	100	130	150	180	200	230	250
955 Eff Pipe	A 982	999	1016	1033	1051	1068	1102	1102
	B 802	809	816	823	831	838	852	852
455 Eff Pipe	A 629	646	663	680	698	715	749	749
	B 449	456	463	470	478	485	499	499
205 Eff Pipe	A 452	469	486	503	521	538	572	572
	B 272	279	286	293	301	308	322	322
150 Eff Pipe	A 417	434	451	468	486	503	537	537
	B 237	244	251	258	266	273	287	287

### Double 90° Bend C/W Pipe Length

Int Ø mm	80	100	130	150	180	200	230	250
955 Eff Pipe	A 296	315	345	366	415	414	445	464
	B 1251	1270	1300	1321	1370	1369	1400	1419
455 Eff Pipe	A 296	315	345	366	415	414	445	464
	B 751	770	800	821	870	869	900	919
205 Eff Pipe	A 296	315	345	366	415	414	445	464
	B 501	520	550	571	620	619	650	669
150 Eff Pipe	A 296	315	345	366	415	414	445	464
	B 446	466	495	516	565	564	595	614

## BS EN 15287-1 ACCEPTABLE ALTERNATIVE METHODS OF CONNECTION

Where a horizontal connecting flue of more than 150mm is required to connect a solid fuel fired appliance to a chimney, an installation method as per the examples below may be used provided the following criteria is met:-

- The maximum length of horizontal connecting flue pipe does not exceed 450mm;
- A Defra exempt appliance or an appliance, which is limited to burning authorised smokeless fuel only, is installed;
- A calculation according to BS EN 13384-1 has indicated safe operation of the proposed configuration, and the results of the calculation are left with the householder along with the appliance installation instructions;
- The appliance manufacturer agrees in writing to the proposed configuration;
- The chimney manufacturer agrees in writing to the proposed configuration;
- The total length of single wall connecting flue pipe is not more than 1.5m;
- The appropriate distances to combustible materials from both the appliance and the connecting flue pipe are maintained.

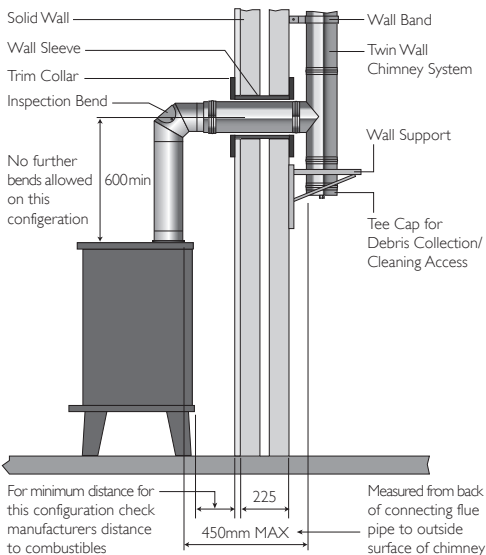

### Top Outlet Single Wall Connecting Flue Pipe through Solid Wall into Twin Wall System Chimney

NB Where the connecting flue pipe from the appliance passes through any wall other than the existing chimney wall, the connecting flue pipe must be a System Chimney of twin wall insulated design.

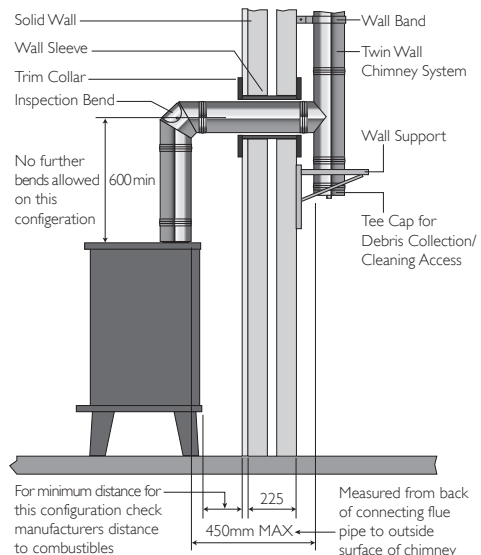

### Top Outlet Twin Wall Connecting Flue Pipe through Solid Wall into Twin Wall System Chimney

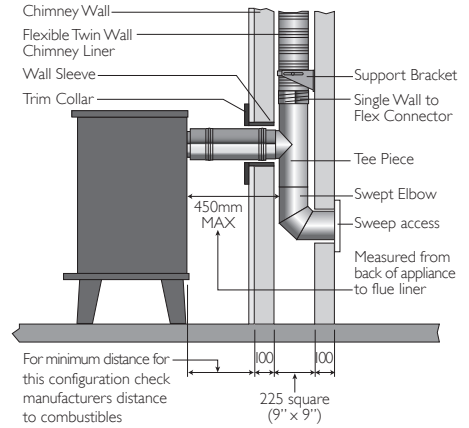
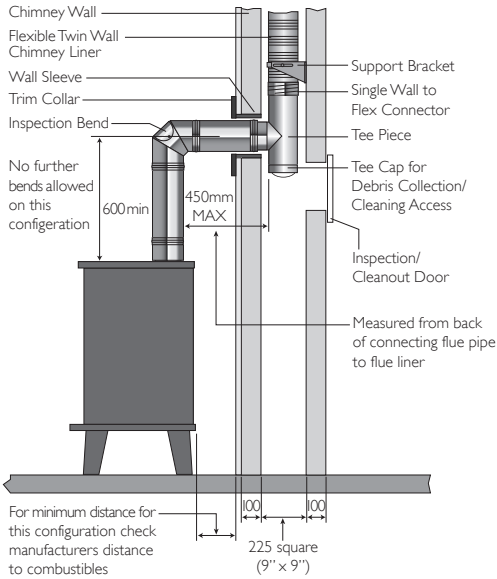

**Top Outlet Twin Wall Connecting Flue Pipe into Re-lined Masonry Chimney**

**Rear Outlet Twin Wall Connecting Flue Pipe into Re-lined Masonry Chimney**

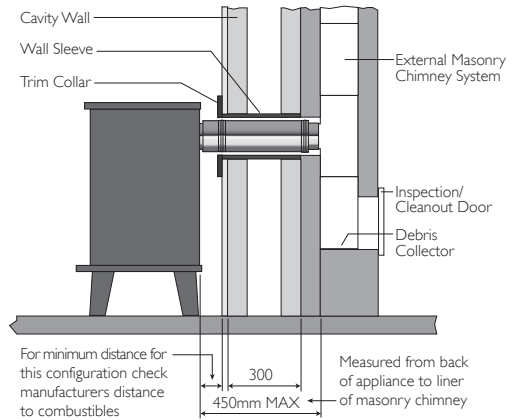
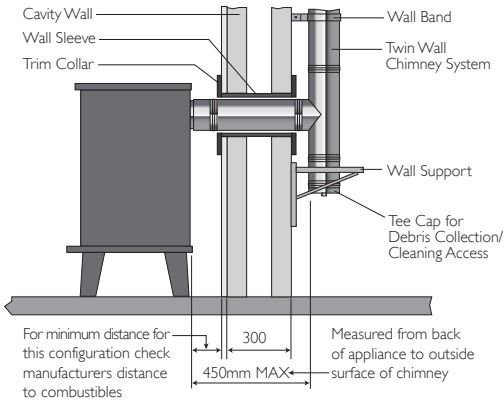

**Rear Outlet Twin Wall Connecting Flue Pipe Through Cavity Wall into Twin Wall System Chimney**

**Rear Outlet Twin Wall Connecting Flue Pipe into External Masonry Chimney through a Cavity Wall**

## FIRESTOP COMPONENTS

### Ventilated Support Plate (Galvanised with S/S Band)

The support plate is used where the chimney passes through a combustible floor; and the weight of the chimney has to be taken at floor level. The support plate must be firmly fixed by using bolts or screws. For load bearing Data refer to tables 1 and 2 on page 14.

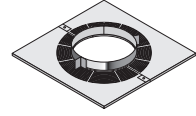

1. Frame a four sided level square opening within the joists using timber stringers where necessary to allow for the correct distance to combustibles from the outer wall of the chimney. This distance must be a minimum of 50mm on Gas and Oil applications and 60mm for solid fuel applications (see Fig. 3 below - distance x).
2. Lower the chimney section through the opening in the floor; and secure to the next section of pipe.
3. Locate the two halves of the support plates around the chimney section, and secure to the joists using screws or bolts.
4. Remove the screws which are fastened to the clamp band. Then fasten clamp band around the chimney section and position on top of the plate. Tighten using the nuts and bolts provided.
5. Using the holes in the clamp support ring drill 3mm holes in the outer casing of the chimney section (drill bit should be set for a depth no greater than 10mm to avoid damage to the liner).
6. Using the screws provided secure the clamp support ring to the outer casing of the chimney section.

**Note: Joints must NOT occur within the floor or ceiling joists.**

#### Ventilated Firestop Plate

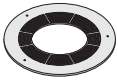

#### Non-Ventilated Bungalow Firestop

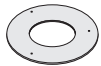

Fig. 2

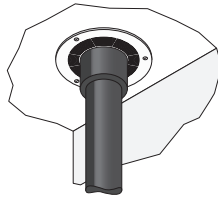

Fig. 3

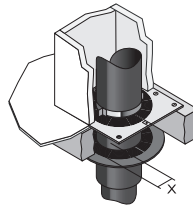
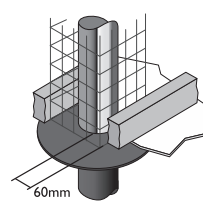

Fig. 4



### Ventilated Firestop Plate (1 & 2-Piece Round and 2-Piece Rectangular)

The ventilated fire stop plates are used in combination with standard ICS pipes where the chimney passes through a combustible floor or ceiling. The outermost circle of ventilation slots gives a distance to combustibles of 60mm. This measures the required distance for solid fuel applications. For gas and oil applications a minimum of 50mm is required, which should be measured on site. The fire stop plate should be positioned around the chimney and fastened to the pre-cut plasterboard or to the timber frame with nails or screws using the location holes provided (see Fig. 2 above).

### Non-Ventilated Bungalow Firestop (1 & 2-Piece Round and 1-Piece Rectangular)

Installed as per a ventilated firestop using the ventilation holes provided (see Fig. 4 above). Distance to combustibles must be respected - see p.3 for further info.

### Support Plate with S/S Clamp Band (Non Combustible Floor)

The support plate is used where the chimney passes through a non combustible floor; and the weight of the chimney has to be taken at floor level. The support plate must be firmly fixed to the floor using bolts or screws provided by others. For load bearing Data refer to table on page 17.

### Fire stop Plate (Non Combustible Floor)

This fire stop plate is used exclusively where the chimney passes through a non combustible floor. The two halves of the plate are located around the chimney section and fastened to the floor using bolts or screws provided by others.

## SUPPORT COMPONENTS

### Wall Band (50/60mm)

#### Internal and External Application

The wall band is supplied in three parts, two stainless steel split bands which fit tightly around the outside of the chimney and a stainless steel back bracket. The parts are joined together by means of the nuts and bolts provided. The use of the item maintains a fixed distance of 50/60mm depending on the wall band type chosen from the outer casing of the chimney to the wall or fixing point.

1. Once the position of the support has been determined, secure the back bracket to the wall with a method of fixing to ensure adequate attachment and support.
2. The stainless steel split band is then positioned around the chimney section and secured with the nuts and bolts provided to the back bracket.
3. The wall bracket provides lateral stability only, it is NOT load bearing and is to be positioned at 3 metre centres.

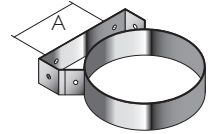

**Wall Band (50/60mm)**

### Adjustable Back Bracket 60-300mm

#### Internal and External Application

The adjustable wall bracket is supplied in three parts, a 'U' shaped stainless steel adjustable section, two bolts for fixing the wall band to the back bracket and a strengthening cross bracket.

1. Once the position of the support has been determined, secure the U shaped bracket to the wall with a method of fixing to ensure adequate attachment and support.
2. Determine the amount of extension required and secure the back bracket of the wall band in place onto the adjustable section.
3. Fasten the strengthening cross bracket in place using the bolts provided.
4. With the back bracket in place, locate the rear portion of the band onto the back bracket, the outer part of the band is then positioned around the chimney section and secured with the nuts and bolts provided.
5. The adjustable wall band provides lateral stability only, it is NOT load bearing and is to be positioned at 3 metre centres.

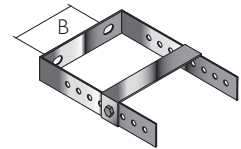

**Adjustable Back Bracket 60-300mm**

Int Ø	80	100	130	150	180	200	230	250
Ext Ø	130	150	180	200	230	250	280	300
A	81	88	131	148	179	198	185	249
B	72	81	112	132	162	182	214	232
C	25	25	25	25	25	25	25	25

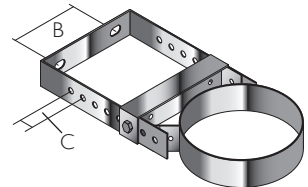

**Wall Band and Adjustable Back Bracket Assembly**

## Structural Wall Band

The structural wall band is supplied in two parts, a stainless steel split band which fits tightly around the outside of the chimney and a stainless steel back bracket. The parts are joined together by means of the nuts and bolts provided. The use of the item maintains a fixed distance of 50mm from the outer casing of the chimney to the wall or fixing point. It can be used in combination with the structural wall band extension components to provide for adjustment to various distances from the wall.

1. Once the position of the support has been determined, secure the back bracket to the wall with a method of fixing to ensure adequate attachment and support.
2. The stainless steel split band is then positioned around the chimney section and secured with the nuts and bolts provided to the back bracket.
3. The wall bracket provides lateral stability only, it is NOT load bearing and is to be positioned at maximum 4 metre centres.

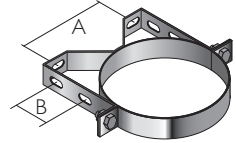

**Structural Wall Band**

Int Ø	80	100	130	150	180	200	230	250
Ext Ø	130	150	180	200	230	250	280	300
A	100	120	150	170	200	220	250	270
B	55	55	55	55	55	55	85	85

## Structural Wall Band Extensions

Available in 3 different sizes. Type W1 gives adjustment of between 55-100mm from the wall. L1 gives adjustment of between 100-250mm from the wall and L2 gives adjustment of between 100-440mm from the wall.

1. Once the position of the support has been determined, secure the back bracket to the wall with a method of fixing to ensure adequate attachment and support.
2. Fasten the structural wall band to the extension brackets using the nuts and bolts provided.

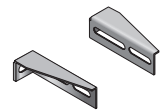

**Type W1**

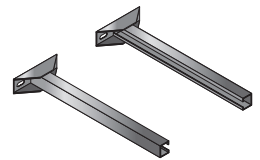

**Type L1 & L2**

**Structural Wall Band Extensions**

Int Ø	80	100	130	150	180	200	230	250
Ext Ø	130	150	180	200	230	250	280	300
C	174	194	224	244	274	294	324	344
D	248	268	298	318	348	368	398	418
E	110	110	110	110	110	110	110	110

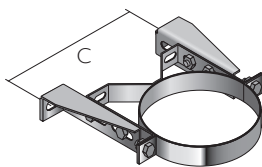

**Structural Wall Band with Type W1 Extension Assembly**

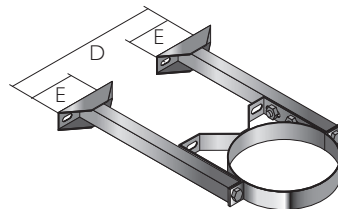

**Structural Wall Band with Types L1 & L2 Extension Assembly**

## Base support Plate with Drain

This component is used to support the chimney directly from the floor. It should be fastened securely to the floor using bolts or screws provided by others.

## Adjustable Top Plate

The wall support is designed to be used internally or externally to provide either initial or intermediate support for the vertical chimney. It is used in combination with side plates or with cantilever brackets. The turned down edge at the front of the plates is slotted to allow for the plate to slide along the cantilever brackets and give some positional adjustment. The female socket on the pipe attached to the underside of the plate should be pushed down onto the preceding pipe and the joint secured using the locking band provided. The top plate is then attached to the side plates or the cantilever brackets using the bolts provided through the fixing slots in the top plate (see Fig. 1). The bolts should then be tightened firmly.

For maximum height of chimney see load bearing details, please refer to tables and diagrams on page 15 and page 16.

Int Ø	80	100	130	150	180	200	230	250
A	230	250	280	300	330	350	380	400

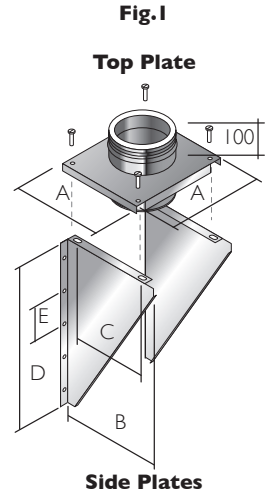

## Side Plates/Cantilever Brackets

Once the position of the support has been established in relation to the chimney route, secure the side plates or cantilever brackets to the wall using expansion bolts to ensure adequate attachment and support (see Fig. 2).

### Wall Support Side Plates

Int Ø	80	100	130	150	180	200	230	250
B	215	235	265	285	315	335	365	385
C	145	165	195	215	245	265	295	315
D	470	470	470	470	470	470	470	470
E	100	100	100	100	100	100	100	100

### Cantilever Supports

Type	325	475	570
Ø Range	80-150	80-250	80-250
A	325	475	570
B	242	242	330

### Cantilever Support Adjustment

Int Ø	80	100	130	150	180	200	230	250
C max								
Type 325	184	164	134	114	84	64	-	-
Type 475	334	314	284	264	234	214	184	164
Type 570	429	409	379	359	329	309	279	259
C min								
Type 325	50	50	50	50	50	50	50	50
Type 475	50	50	50	50	50	50	50	50
Type 570	50	50	50	50	50	50	50	50

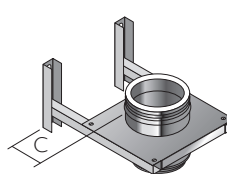
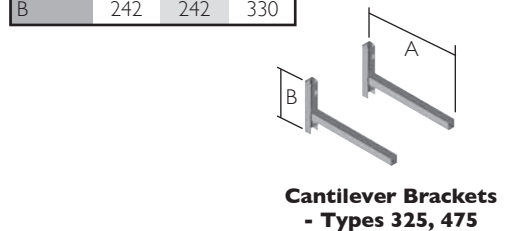

**Cantilever Support Adjustment**

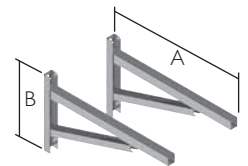

**Cantilever Bracket - Type 570**



## Roof Support

The roof support is supplied as a kit complete with two side plates for fixing to the roof trusses, a band to give lateral support to the chimney as it passes through the roof, and 3 self tapping screws, which are secured to the chimney through the band to give a load bearing capacity. When the plates are installed above the roof trusses as in Fig. 1 the maximum number of pipes, which may be suspended from the roof support is 6 x 1m pipes. When the plates are attached below the trusses as in Fig. 2 the maximum number of pipes, which may be suspended is 4 x 1m pipes.

1. The band should be lowered down over the top of the ICS pipe, and positioned so that the side plates are resting on top of the roof trusses as in Fig. 1 or below the roof trusses in the case of Fig. 2. The recommended position is always as per Fig. 1 where circumstances allow this solution.
2. The band should then be tightened using the nut and bolt provided.
3. Using the holes pre-drilled in the roof support band, drill 3mm holes in the outer case of the chimney section (drill bit should be set for a depth no greater than 10mm to avoid any damage to the liner of the chimney)
4. Use the self tapping screws provided to secure the clamp band to the outer casing of the chimney section.

**Please note:** It is the responsibility of the installer to ensure that the joist to which the roof support is being attached is load bearing and capable of withstanding the weight of the system being installed.

## Guy Wire Bracket

This component should be used to secure unsupported chimney sections above roof level. Guy wires or preferably rigid stays (supplied by others) must be fixed to the bracket and secured to suitable anchorage points to ensure that the chimney sections are stable.

A maximum chimney height of 1.5 metres from the last support, or from the roof is permitted. Additional height requirements MUST be supported at 1.5 metre intervals using the guy wire bracket as specified above.

## Ceiling Hanger

This accessory is designed to support horizontal runs of the chimney from the roof or ceiling and offers adjustment from 130mm to 1115mm.

1. Once the position of the ceiling support has been determined, the section length of uni-rax channel must be securely fixed to the roof or the ceiling using a method of attachment to ensure adequate attachment and support.
2. All items are assembled as shown to attach the length of studding to the channel.
3. Attach the stud connector to the length of studding and connect the eye bolt to the connector.
4. Position the split band around the chimney section and secure to the eye bolt using the nut/bolt provided.
5. Maximum support spacing to be no more than 1.5 metres.

Fig. 1

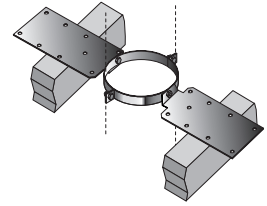
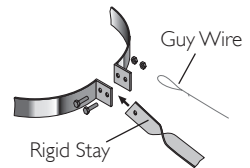
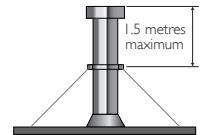
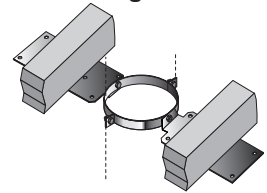
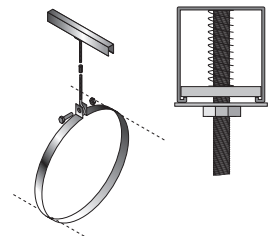

Fig. 2



Guy Wire Bracket



Ceiling Hanger

### Wall sleeve (90° & 135° variants)

Wall sleeves must be used to protect the building where the chimney passes through a wall (see Fig. 2 & 3). The 90° version is supplied as a straight length whereas the 135° version is mitred at 45 degrees on one end. The sleeve should be cut down to the correct length on site to fit flush with the wall (see Fig. 1 & 2). The sleeve should be adequately weatherproofed, using a good quality building mastic and rope fibre.

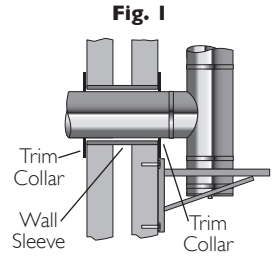

### Two Piece Trim Collar (90° & 135° variants)

Two piece trim collars are fitted around the ICS pipe where it protrudes through both the inside and the outside of the wall (see Fig. 1 & 2). They should be fastened to the wall using an adequate method of fixing. The trim collars should be adequately weatherproofed back to the wall and around the chimney, using a good quality building mastic or equivalent.

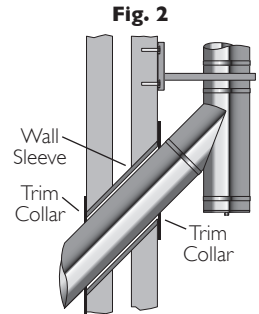

### Flat Flashing

Manufactured in sheet aluminium for use on flat roofs the base of the flashing should be covered by the roofing felt and then sealed. This component should be sealed with the mastic sealant provided and MUST be used in conjunction with the storm collar supplied.



### Storm Collar

The storm collar should be sealed to the outer casing of the flue immediately above the flashing with the mastic sealant provided.



### Uniflash

This item, which is manufactured with a malleable base and a silicone cone is used to provide a water tight flashing around the chimney as it passes through a roof pitched between 0-45 degrees. The cone is marked with pipe diameter sizes.

1. Cut the cone to suit the correct diameter of chimney.
2. Slide the flashing down over the top of the pipe and then form the base to the shape of the roof surface.
3. Seal as required.

Ext Ø	80-200	150-300	250-450
A	500	685	800

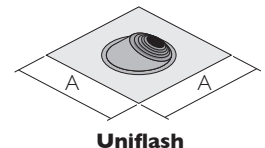

## Terminals

Terminals are supplied complete with a locking band. Once the terminal has been pushed into place, the adjustment bolt on the locking band clip should be tightened to ensure that the terminal is properly secured to the previous pipe.

**Tapered Terminal**



**Raincap**



**Anti Splash Terminal**

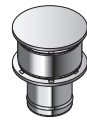

## OUTLET SITING

Flue terminations for solid fuel & oil are subject to EN15287-1 2007. Figures A and B illustrate recommendations for the most commonly encountered outlet terminations. Flue terminations for gas in domestic situations are governed by the BS5440-1 2008 Section 4.2. Figure C illustrates recommendations for the most common siting situations encountered. Adjacent taller structures may require increased height. The minimum flue projection through the roof is 600mm to the underside of the terminal.

### Outlet siting for Oil Appliances (<45kW)

Location of outlet	Pressure Jet Burner	Vapourising Burner
<b>M</b> Above the highest point of an intersection with the roof	600mm	1000mm
<b>N</b> From a structure to the side of the terminal	750mm	2300mm
<b>O</b> Above a vertical structure which is less than 750mm (pressure jet burner) or 2300mm (vapourising burner) horizontally from the side of the terminal	600mm	1000mm
<b>P</b> From a ridge terminal to a vertical structure on the roof	1500mm	Should not be used

**Fig. A**

Outlet siting for Oil Appliances (<45kW)

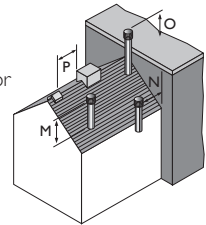

**Fig. B**

Outlet siting for Solid Fuel Appliances (<50kW)

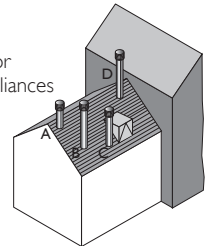

**Fig. C**

BS 5440-1  
Outlet siting for Gas Appliances (<70kW)

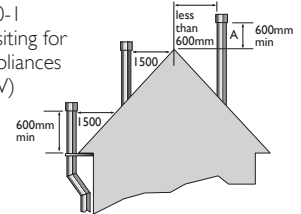

### Outlet siting for Solid Fuel Appliances (<50kW)

Point where flue passes through weather surface (Notes 1, 2)	Clearance to flue outlet
<b>A</b> At or within 600mm of the ridge	At or within 600mm above the ridge
<b>B</b> Elsewhere on the roof (whether pitched or flat)	At least 2300mm horizontally from the nearest point on the weather surface and a) at least 1000mm above the highest point of intersection of the chimney and the weather surface; or b) at least as high as the ridge
<b>C</b> Below (on a pitched roof) or within 2300mm horizontally to an openable rooflight, dormer window or other opening (Note 3)	At least 1000mm above the top of the opening
<b>D</b> Within 2300mm of an adjoining or adjacent building, whether or not beyond the boundary (Note 3)	At least 600mm above any part of the adjacent building within 2300mm

1. The weather surface is the building external surface, such as its roof, tiles or external walls.
2. A flat roof has a pitch less than 10°.
3. The clearance for A or B, as appropriate, will also apply.
4. A vertical flue fixed to an outside wall should be treated as equivalent to an inside flue emerging at the nearest edge of the roof.

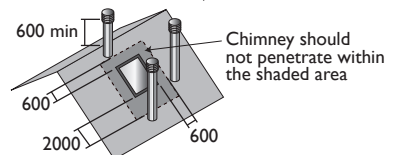

# TYPICAL EXTERNAL INSTALLATIONS

## Floor Mounted Installation with Base Drain Section

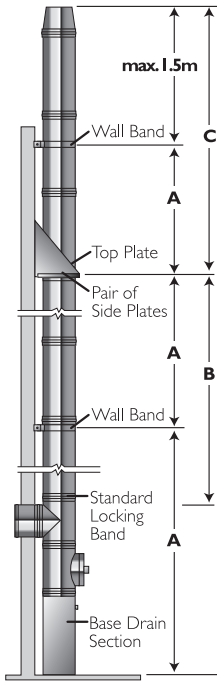

## Wall Mounted Installation with pair of Cantilever Brackets and Structural Locking Bands

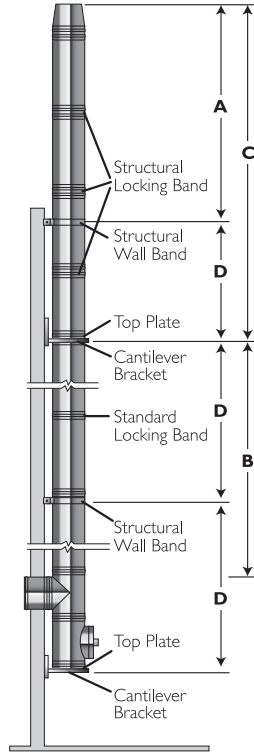

## Offset Installation (45°) with pair of Side Plates

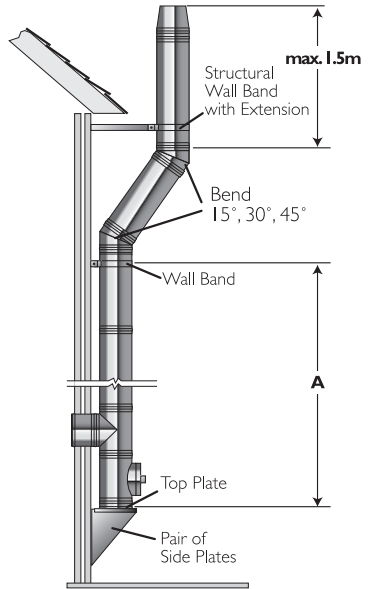

### Distance between Lateral Supports

Int Ø (mm)	A (m)	B (m)	C (m)	D (m)
80	3	22	15	4
100	3	22	12	4
130	3	22	15	4
150	3	18	15	4
180	3	18	15	4
200	3	18	18	4
230	3	18	15	4
250	3	18	15	4

### Max Offset Info (in same plane)

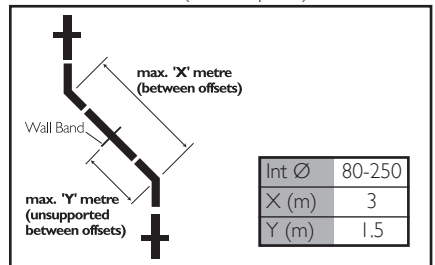

## LOAD BEARING DATA

### Maximum Load Bearing (metres of pipe)

Internal Diameter (mm)	80-130	150-180	200-250
Base Drain Section	22	18	18
Adjustable Top Plate + Locking Band	15	15	15
Telescopic Floor Support	18	18	18
Pair of Side Plates (see diagram A)	15	15	15
Pair of Side Plates (see diagram B)	10	10	10
Cantilever Support	22	18	18
Extension Support (Anchor Plate)	1.5	1.5	1.5
Ventilated Support Plate (All types)	12	12	9
Support Plate	12	12	9
Ceiling Hanger	1.5	1.5	1.5
Wall Band 50/60mm	3	3	3
Adjustable Wall Band 60-300mm	3	3	3
Structural Wall Band	4	4	4
Extension for Structural Wall Band	4	4	4
Guy Wire Bracket	1.5	1.5	1.5
Roof Support (above truss)	6	6	6
Roof Support (below truss)	4	4	4
90° Tee + Locking Band	22	18	18
93° Tee + Locking Band	22	18	18
135° Tee + Locking Band	15	10	10
Inspection Tee (Round)	22	18	18
Inspection Tee (Rectangular)	22	18	18

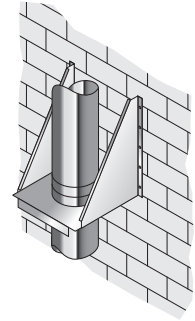

Diagrame A

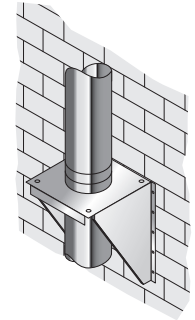

Diagrame B

## COMPONENT WEIGHTS

### Approximate Weights of Finished Goods (Kg)

Internal Diameter	Length(mm)	1000	500	250	195
80mm		4.32	2.13	1.09	0.85
100mm		5.14	2.53	1.29	1.01
130mm		6.35	3.14	1.60	1.24
150mm		7.18	3.54	1.86	1.41
180mm		8.40	4.14	2.11	1.65
200mm		9.22	4.55	2.31	1.80
230mm		10.44	5.13	2.62	2.03
250mm		11.24	5.53	2.81	2.19

## AFTER INSTALLATION

### Testing Before Use

This is carried out using a flue flow test as described in BS EN 15287 parts 1 & 2, with reference to the appropriate appliance type.

### Maintenance

Each chimney must be designed to allow for easy inspection; sweeping should be carried out by competent persons. On solid fuel applications a list of HETAS registered sweeps can be found at [www.hetas.co.uk](http://www.hetas.co.uk) Chimney flue cleaning and inspection require the use of appropriate tooling – under no circumstances should mild steel tools be used to sweep stainless steel chimneys. Cleaning/inspection of any chimney system should be carried out at least once a year; along with maintenance of the appliance, but it is recommended that chimneys serving solid fuel appliances be swept at least twice a year.

## CHIMNEY PLATE

### Notice Plate for ICS Product

The Notice plate should be marked up in indelible ink and securely fixed in an unobtrusive but obvious position within the building such as:

- Next to the electricity consumer unit.
- Next to the chimney installation described.
- Next to the water supply stop-cock.

See example below:





CHIMNEY SYSTEMS

### IMPORTANT SAFETY INFORMATION

THIS NOTICE MUST NOT BE REMOVED OR COVERED

PROPERTY ADDRESS Smiths Cottage, Thatchville

THE CHIMNEY/FLUE/HEARTH IS INSTALLED IN THE Lounge

SYSTEM IS SUITABLE FOR:- SOLID FUEL  GAS  OIL(28 SEC)  OTHER

APPLIANCE IS CONDENSING YES  NO  (IF YES) TYPE OF SEAL FITTED: S000 (GAS)  V000 (OIL)

APPLIANCE INSTALLED IS A Wood burning stove

FLUE TYPE:

TRIPLELOCK  TECNOFLEX  Eco ICID  ICS

PRIMA +  PRIMA SMOOTH  K-VENT  B-VENT

DATE OF INSTALLATION: 10/05/11 REF: job no. 99991

INSTALLER NAME/ADDRESS: A.N. Installer, Home Street, Washington, Tyne and Wear, NE38 0AB

OTHER INFORMATION System Chimney

CHIMNEY DESIGNATION T450-N1-W-VZ-L50050-G60 FLUE SIZE Ø 150mm  
(Refer to product/packaging label for designation to EN 1856)

**IMPORTANT**  
PLEASE ENSURE THAT THE APPLIANCE IS OPERATED IN ACCORDANCE WITH THE MANUFACTURER'S RECOMMENDATIONS. IT IS ADVISED THAT THE SYSTEM IS REGULARLY SERVICED/SWEPT IN ACCORDANCE WITH THE INSTALLATION INSTRUCTIONS TO ENSURE THAT THE SYSTEM OPERATES EFFICIENTLY.

PLEASE ENSURE THAT ALL THE INFORMATION IS FILLED IN WITH THE USE OF PERMANENT INK

## PRODUCT WARRANTY

Under normal operating conditions and providing the system is installed correctly, it should last the lifetime of the appliance, which normally is 10 years. ICS carries a 10 year conditional warranty. The conditions are that the system is:-

- Correctly sized and installed in accordance with the manufacturer's instructions, current Building Regulations and relevant British and European standards.
- Maintained correctly by a qualified and competent person and maintenance records kept updated for both appliance and system chimney.
- Used in combination with an appliance burning only approved fuels in accordance with Schiedel Chimney Systems and the appliance manufacturer's instructions.

For recommended fuels listings, please refer to the HETAS Guide [www.hetas.co.uk](http://www.hetas.co.uk)

In the event of a fault developing in the product due to defective materials or faulty manufacture Schiedel Chimney Systems undertake to replace the product only.

Schiedel Chimney Systems cannot accept liability nor take any responsibility for the installation, building or redecorating costs or any other consequential losses arising.

If any complaint is found to be a result of faulty installation, non-compliance with or abuse contrary to these conditions, the cost of site investigation is chargeable.



### Product Registration

The installer/customer is required to fill in the details below and return the registration form to Schiedel Chimney Systems. Failure to register the installation may affect any claim made during the warranty period of the product.

Name & Address of Installer:		Address of property where product installed:	
Supplier/Stockist:		Date of Purchase:	
Occupier of Property:	Date of Installation:	Product Installed:	
Appliance Type/Model:			
Internal Flue Diameter:		Fuel Type:	

# Complementary products and services from Schiedel Chimney Systems

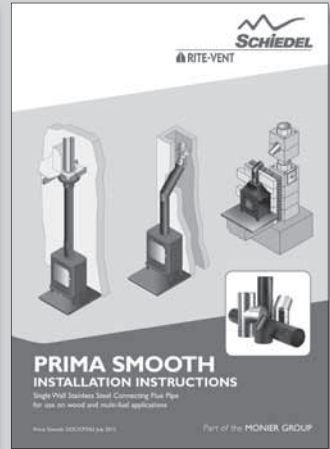
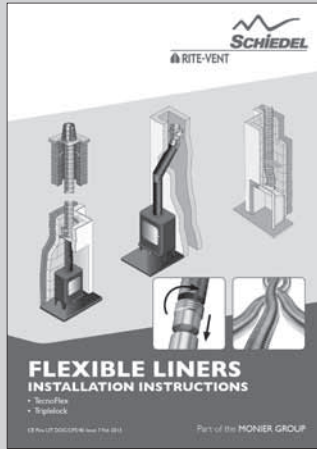
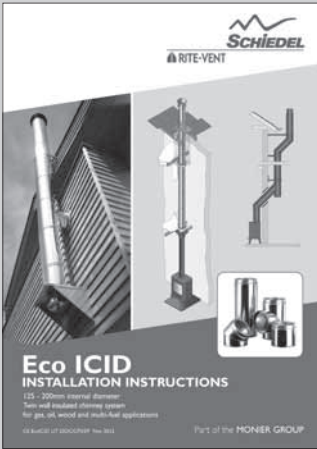

ECO ICID

FLEXIBLE LINERS

PRIMA SMOOTH

## HETAS TRAINING

Courses H001-H006 available. See website for course prospectus and application form downloads or scan QR code below.



### Schiedel Chimney Systems

Crowther Estate  
Washington  
Tyne & Wear NE38 0AQ  
Tel. +44 (0)191 416 1150  
Fax. +44 (0)191 415 1263  
info@schiedel.co.uk

[www.schiedel.co.uk/rite-vent](http://www.schiedel.co.uk/rite-vent)

