



In a world of ever increasing complexity, we take a step back and start our range of stoves with the multi-talented Bubble 1. Top quality castings with a clean and simple design, this stove is a little gem with a variety of uses. Easy to light, use and maintain, it will give

years of pleasure and low cost heating. Available in three versions dry, small boiler and large boiler with the most realistic coal effect yet achieved and choice of colours.

Silent simplicity just for you.

Features common to all Bubble Stoves

- Can be supplied with or without a coal effect kit.
- Coal kits are all one piece, making fitting and removal quick, easy and convenient.
- All stoves can run at an output setting of 5kW on chimneys less than 2.5 metres high.
- Manual or automatic controls.
- Easy to maintain and service.
- Built in Barometric damper.
- Silent in operation.
- Simple and reliable.
- Top or Rear flue (except Inset). (Specify when ordering).
- 28 or 35 second versions available.

BUBBLE 1 STOVES



Features specifically for Bubble 1

- Smallest oil stove currently available.
- Incredible economy (see flow rates on price sheet).
- 3 versions and colours.
- Two verticals or one rear flue positions.
- Can be used reliably where low cost heating is required without an electricity supply in conservatories, leisure homes, games rooms and cottages.



CORNER BUBBLE OIL FIRED

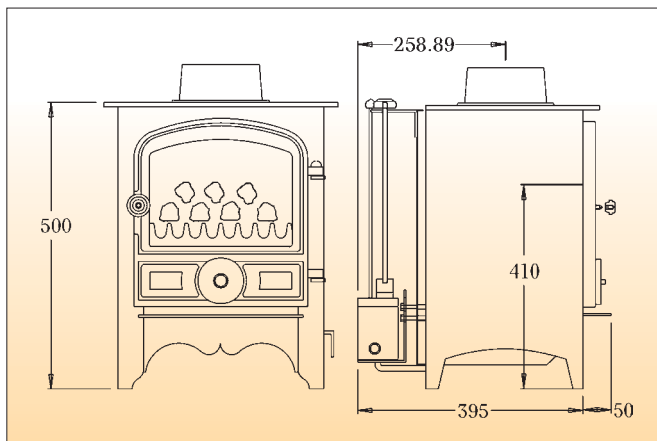

Harworth Heating Limited,
Blyth Road, Harworth, Doncaster, South Yorkshire DN11 8NE.
Tel: 01302 742520 3 lines Fax 01302 750573
www.oilstoves.co.uk Sales@oilstoves.co.uk



FLEX A FLAME CONVERTA KIT



To ensure performance as specified, Bubble stove must be installed by competent persons.

Flame effect may differ from photographic representation on this brochure.

Your Local Dealer